

M-14-08
REV. E
JUNE 2016

Installation Manual Contains:

- Warnings & Safety Instructions
- Requirements - Body Strength & Installed Liftgate
- Liftgate Installation Components
- Liftgate Component Installation Instructions
- Hydraulic Fluid Filling Instructions
- Decals
- Hydraulic & Electrical System Diagrams
- Pre-delivery Inspection Form

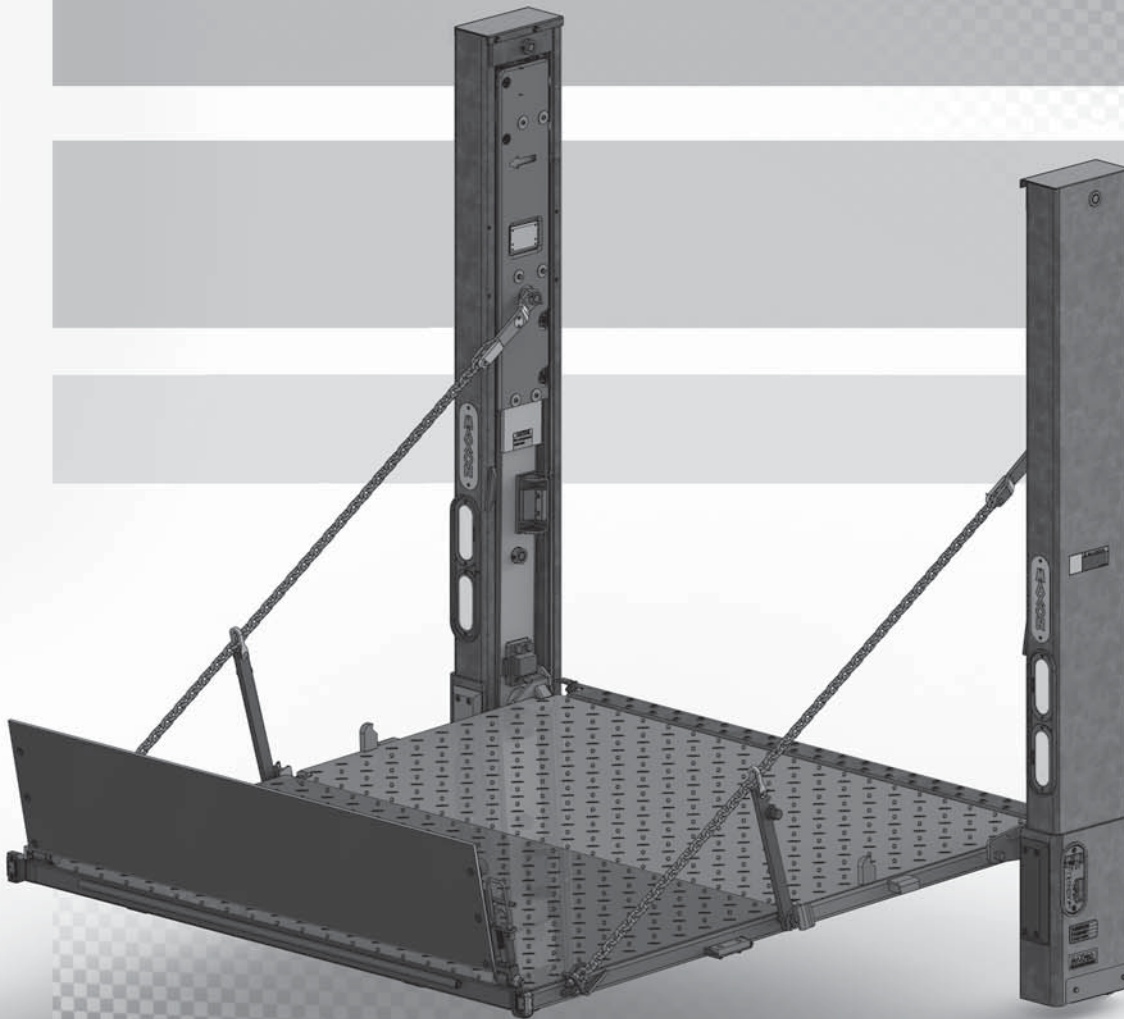

[®]
MAXON
LIFT CORP.

To find **maintenance & parts** information for your **BMR Liftgate**, go to www.maxonlift.com. Click the **PRODUCTS, COLUMNLIFT & BMR** buttons. Open the **Maintenance Manual** in the **PRODUCT DOCUMENTATION** window.

BMR

INSTALLATION MANUAL

TABLE OF CONTENTS

SUMMARY OF CHANGES: M-14-08, REVISION E	5
WARNINGS	6
VEHICLE REQUIREMENTS	8
BODY STRENGTH.....	8
INSTALLED LIFTGATE	12
LIFTGATE INSTALLATION COMPONENTS	13
COMPONENTS	14
STEP 1 - PREPARE VEHICLE IF REQUIRED	17
STEP 2 - CHOOSE METHOD OF INSTALLATION.....	19
STEP 3 - POSITION LIFTGATE	20
METHOD 1 - PRE-INSTALL MOUNTING PLATES AND EXTENSION PLATE ON VEHICLE.....	20
METHOD 2 - PRE-INSTALL MOUNTING PLATES AND EXTENSION PLATE ON LIFTGATE	24
METHOD 3 - WELD LIFTGATE TO BODY.....	30
STEP 4 - BOLT LIFTGATE TO VEHICLE.....	32
STEP 5 - REMOVE LOWER SUPPORT FIXTURES	37
STEP 6 - POSITION PUMP BOX FRAME	38
STEP 7 - ATTACH PUMP & BATTERY BOX FRAME TO VEHICLE	40
STEP 8 - RUN HYDRAULIC LINES & ELECTRIC CABLES.....	46
RUN GRAVITY DOWN HYDRAULIC LINES	47
RUN POWER DOWN HYDRAULIC LINES	49
RUN ELECTRIC CABLES	51
WIRING HARNESS TWIST-LOCK CONNECTORS.....	52
STEP 9 - CONNECT GROUND CABLE	53

TABLE OF CONTENTS - Continued

GROUNDING TO TRUCK FRAME.....	53
GROUNDING TO BATTERY BOX (IF EQUIPPED).....	54
STEP 10 - RUN CHARGE LINES	55
STEP 11 - CONNECT BATTERIES TO LIFTGATE	59
STEP 12 - ADD HYDRAULIC FLUID TO RESERVOIR	60
STEP 13 - PRESSURIZE HYDRAULIC SYSTEM	61
STEP 14 - OPTIMIZE HYDRAULIC FLUID LEVEL.....	62
STEP 15 - CHECK MOUNTING BRACKET FIT.....	67
STEP 16 - REMOVE UPPER SUPPORT FIXTURES	69
STEP 17 - SECURING COLUMNS.....	70
METHOD 1 AND METHOD 2	70
STEP 18 - FINISH WELDING LIFTGATE TO VEHICLE	75
METHOD 3 - WELD LIFTGATE TO BODY.....	75
STEP 19 - PLATFORM CHAIN ADJUSTMENT	79
STEP 20 - PLACE "ALIGN ARROWS" DECAL.....	81
STEP 21 - ADJUST PLATFORM ASSEMBLY	82
STEP 22 - ACTIVATE PLATFORM LIGHTS.....	83
ATTACH DECALS	84
TOUCH UP GALVANIZED FINISH	86
OPTIONS	87
RECOMMENDED LIFTGATE POWER CONFIGURATION	87
HYDRAULIC SYSTEM DIAGRAMS.....	89
PUMP & MOTOR SOLENOID OPERATION - POWER DOWN.....	89
PUMP & MOTOR SOLENOID OPERATION - GRAVITY DOWN.....	90
GRAVITY DOWN HYDRAULIC SCHEMATIC.....	91

TABLE OF CONTENTS - Continued

POWER DOWN HYDRAULIC SCHEMATIC.....	92
ELECTRICAL SYSTEM DIAGRAMS	93
INTERCONNECTING ELECTRICAL SCHEMATIC.....	93
GRAVITY DOWN SINGLE PUMP ELECTRICAL SCHEMATIC	94
GRAVITY DOWN DUAL PUMP ELECTRICAL SCHEMATIC	95
POWER DOWN SINGLE PUMP ELECTRICAL SCHEMATIC	96
POWER DOWN DUAL PUMP ELECTRICAL SCHEMATIC.....	97
PRE-DELIVERY INSPECTION FORM.....	98

SUMMARY OF CHANGES: M-14-08, REVISION E

PAGE	DESCRIPTION OF CHANGE
COVER	Updated REV and date.
38	Restored the illustration that shows a 15 ft installation.
88	Changed recommended circuit breaker for truck battery to 150 AMP in FIG. 88-1.

Comply with the following **WARNINGS** and **SAFETY INSTRUCTIONS** while installing Liftgates. See Operation Manual for operating safety requirements.

⚠ WARNING

- Do not stand, or allow obstructions, under the platform when lowering the Liftgate. **Be sure your feet are clear of the Liftgate.**
- **Keep fingers, hands, arms, legs, and feet clear of moving Liftgate parts (and platform edges) when operating the Liftgate.**
- **Correctly stow platform when not in use. Extended platforms could create a hazard for people and vehicles passing by.**
- **Make sure vehicle battery power is disconnected** while installing Liftgate. Connect vehicle battery power to the Liftgate only when installation is complete or as required in the installation instructions.
- **Remove all rings, watches and jewelry before doing any electrical work.**
- If it is necessary to stand on the platform while operating the Liftgate, keep your feet and any objects clear of the inboard edge of the platform. Your feet or objects on the platform can become trapped between the platform and the Liftgate extension plate.
- Never perform unauthorized modifications on the Liftgate. Modifications may result in early failure of the Liftgate and may create hazards for Liftgate operators and maintainers.
- Recommended practices for welding on steel parts are contained in the current **AWS (American Welding Society) D1.1 Structural Welding Code - Steel**. Damage to Liftgate and/or vehicle, and personal injury can result from welds that are done incorrectly.
- Welding on galvanized parts gives off especially hazardous fumes. Comply with WARNING decal on the galvanized part (**FIG. 6-1**). To minimize hazard remove galvanizing from weld area, provide adequate ventilation, and wear suitable respirator.

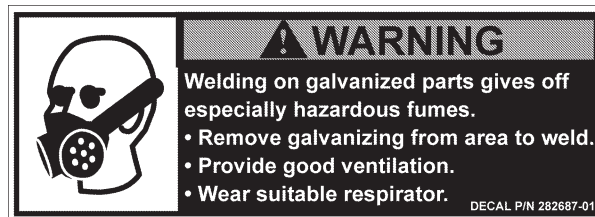

FIG. 6-1

SAFETY INSTRUCTIONS

- Read and understand the instructions in this **Installation Manual** before installing Liftgate.
- Before operating the Liftgate, read and understand the operating instructions in **Operation Manual**.
- Comply with all **WARNING** and instruction decals attached to the Liftgate.
- Keep decals clean and legible. If decals are illegible or missing, replace them. Free replacement decals are available from **Maxon Customer Service**.
- Consider the safety and location of bystanders and location of nearby objects when operating the Liftgate. Stand to one side of the platform while operating the Liftgate.
- Do not allow untrained persons or children to operate the Liftgate.
- Wear appropriate safety equipment such as protective eyeglasses, faceshield and clothing while performing maintenance on the Liftgate and handling the battery. Debris from drilling and contact with battery acid may injure unprotected eyes and skin.
- Be careful working by an automotive type battery. Make sure the work area is well ventilated and there are no flames or sparks near the battery. Never lay objects on the battery that can short the terminals together. If battery acid gets in your eyes, immediately seek first aid. If acid gets on your skin, immediately wash it off with soap and water.
- If an emergency situation arises (vehicle or Liftgate) while operating the Liftgate, release the control switch to stop the Liftgate.
- A correctly installed Liftgate operates smoothly and reasonably quiet. The only noticeable noise during operation comes from the power unit while the platform is raised and lowered. Listen for scraping, grating and binding noises and correct the problem before continuing to operate Liftgate.

VEHICLE REQUIREMENTS

NOTE: Installer is responsible for ensuring vehicle meets Federal, State, and Local standards and regulations.

BODY STRENGTH

⚠ WARNING

Consult vehicle body manufacturer for vehicle body strength data. Make sure the forces created by the Liftgate are within the limits prescribed by the vehicle body manufacturer.

NOTE: Maximum operating bed height for body is **56" (Unloaded)**. Minimum is **44" (Loaded)**. Do not install this Liftgate on vehicle bodies equipped with swing open doors.

The BMR is a body-mounted Liftgate that puts forces on the side walls of truck and trailer bodies (**FIG. 8-1**). For correct installation, truck and trailer bodies must be strong enough to withstand the tension, compression and shear forces shown in **FIG. 8-1**. Use **TABLES 9-1, 9-2, 9-3, and 9-4** on the following page to determine the forces that apply to the type of platform, size of platform, and load capacity of your Liftgate.

X= Tension on each sidewall
Y= Compression on each sidewall
Z= Shear on each sidewall

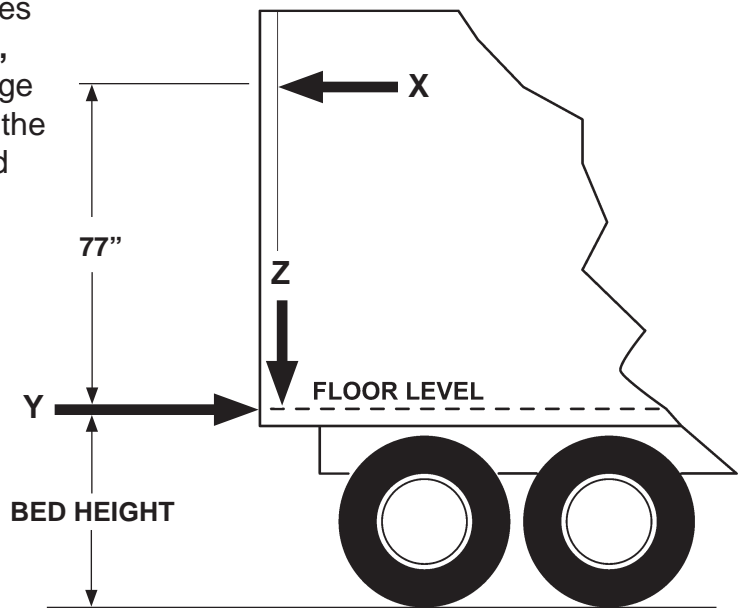

FIG. 8-1

VEHICLE REQUIREMENTS - Continued

BODY STRENGTH - Continued

MODEL CAPACITY	P/F SIZE	(X)(Y) LBS.	(Z) LBS.
BMR-35 3500 LBS. (STEEL PLATFORM)	84	2101	4176
	72	1780	4071
	60	1475	3962
	48	1180	3840
	42	1043	3786
BMR-44 4400 LBS. (STEEL PLATFORM)	84	2504	4851
	72	2110	4746
	60	1772	4637
	48	1426	4515
	42	1262	4461

TABLE 9-1

MODEL CAPACITY	P/F SIZE	(X)(Y) LBS.	(Z) LBS.
BMR-55 5500 LBS. (STEEL PLATFORM)	84	2998	5676
	72	2559	5571
	60	2137	5462
	48	1726	5340
	42	1529	5286
BMR-66 6600 LBS. (STEEL PLATFORM)	84	3491	6501
	72	2989	6396
	60	2500	6287
	48	2025	6165
	42	1738	6111

TABLE 9-2

MODEL CAPACITY	P/F SIZE	(X)(Y) LBS.	(Z) LBS.
BMR-35 3500 LBS. (ALUMINUM PLATFORM)	84	1785	3683
	72	1580	3649
	60	1339	3619
	48	1081	3533
	42	964	3510
BMR-44 4400 LBS. (ALUMINUM PLATFORM)	84	2233	4358
	72	1931	4324
	60	1637	4294
	48	1326	4208
	42	1183	4185

TABLE 9-3

MODEL CAPACITY	P/F SIZE	(X)(Y) LBS.	(Z) LBS.
BMR-55 5500 LBS. (ALUMINUM PLATFORM)	84	2725	5183
	72	2360	5749
	60	2001	5119
	-	-	-
	-	-	-
BMR-66 6600 LBS. (ALUMINUM PLATFORM)	84	3219	6008
	72	2788	5974
	60	2365	5944
	-	-	-
	-	-	-

TABLE 9-4

VEHICLE REQUIREMENTS - Continued CLEARANCE DIMENSIONS

NOTE: Maximum bed height is 56" (unloaded).
Minimum bed height (loaded) varies with type and size of platform.
Refer to **FIGS. 10-1 & 10-2.**

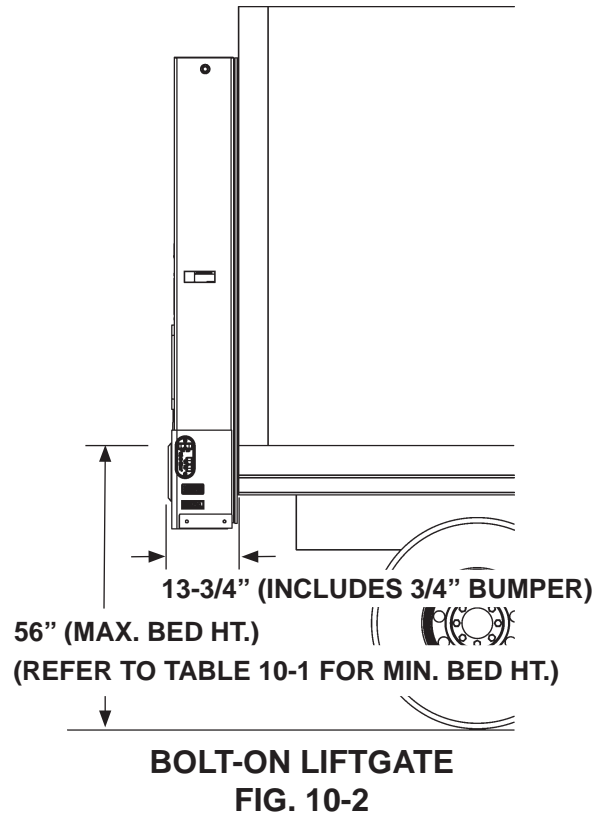
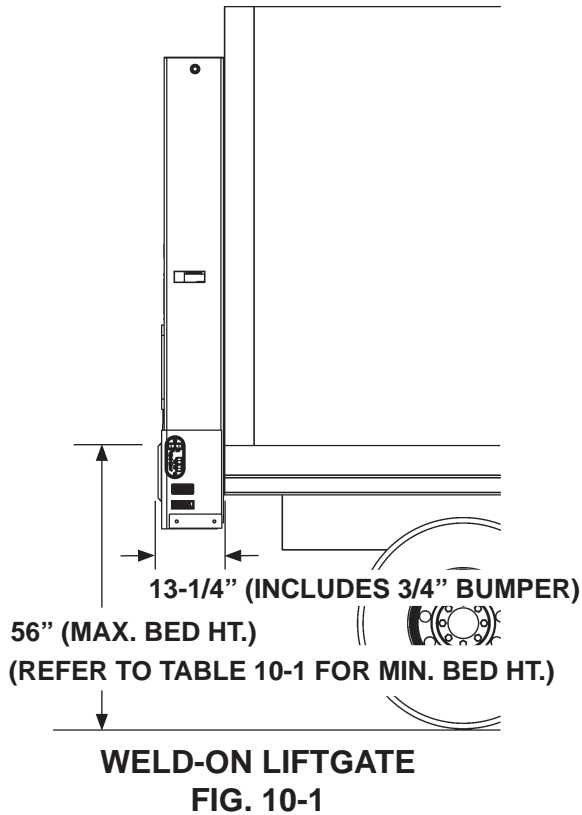

PLATFORM	SIZE	MIN. BED HEIGHT
ALUMINUM	80" X 30"	32"
ALUMINUM	85" X 30"	32"
ALUMINUM	80" X 36"	38"
ALUMINUM	85" X 36"	38"
ALUMINUM	80" X 42"	44"
ALUMINUM	85" X 42"	44"
STEEL	80" X 30"	33"
STEEL	85" X 30"	33"
STEEL	80" X 36"	39"
STEEL	85" X 36"	39"
STEEL	80" X 42"	45"
STEEL	85" X 42"	45"

MINIMUM BED HEIGHT BY PLATFORM TYPE AND SIZE
TABLE 10-1

VEHICLE REQUIREMENTS - Continued

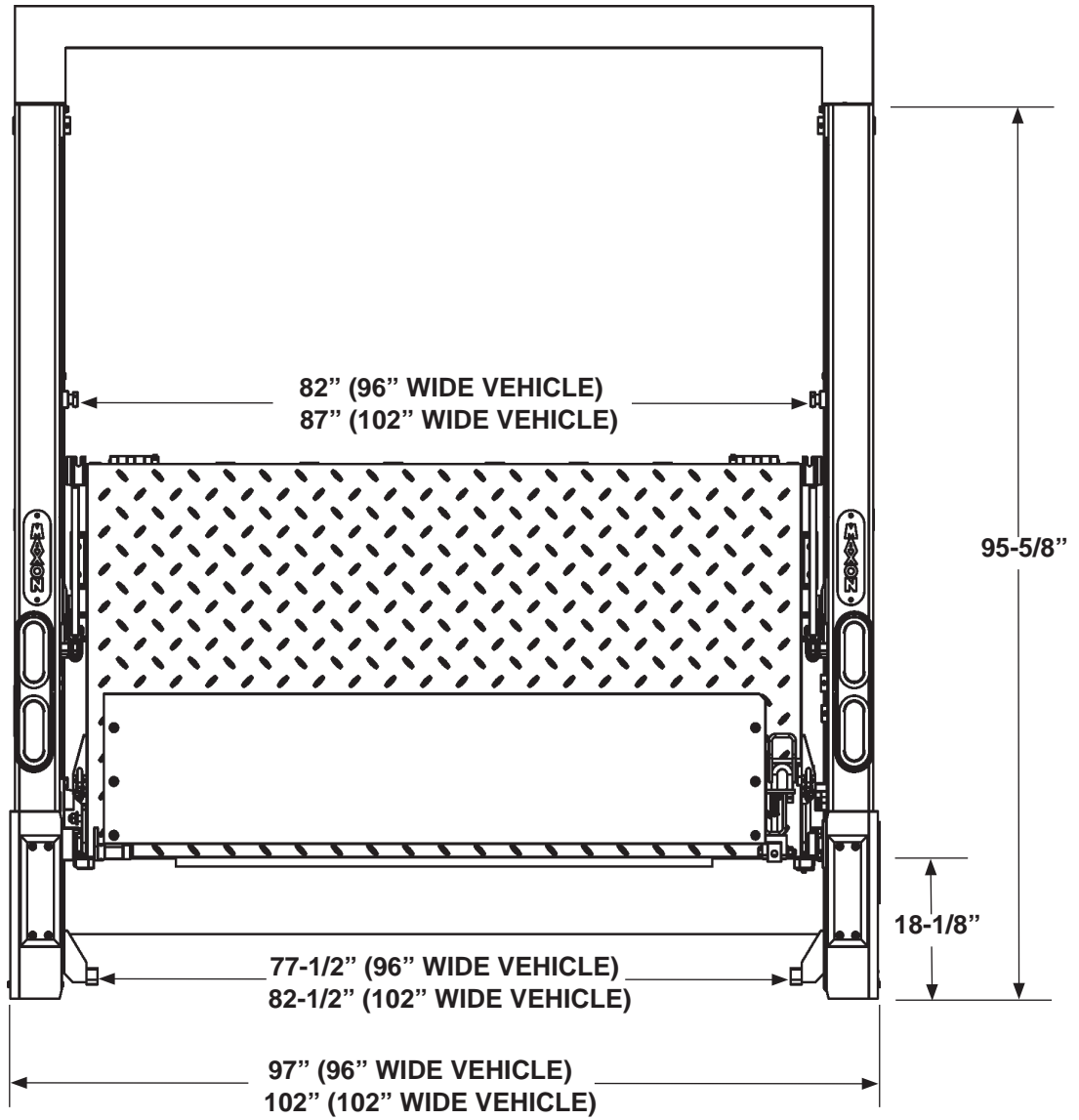

CLEARANCE DIMENSIONS
FIG. 11-1

MAXON[®] 11921 Slauson Ave. Santa Fe Springs, CA. 90670 (800) 227-4116 FAX (888) 771-7713

VEHICLE REQUIREMENTS - Continued

INSTALLED LIFTGATE

NOTE: If Liftgate columns exceed a 91 degree angle from level ground when installed on body, or if columns cannot be mounted flush against rear of vehicle, a steel filler may be used to bridge gap between vehicle body and Liftgate columns. Make sure the added materials and welds meet the **BODY STRENGTH** requirements shown on the previous pages.

With the vehicle parked on level ground, the columns of the BMR must be perpendicular to the ground (vertical) for the Liftgate to operate correctly (**FIGS. 12-1 and 12-2**).

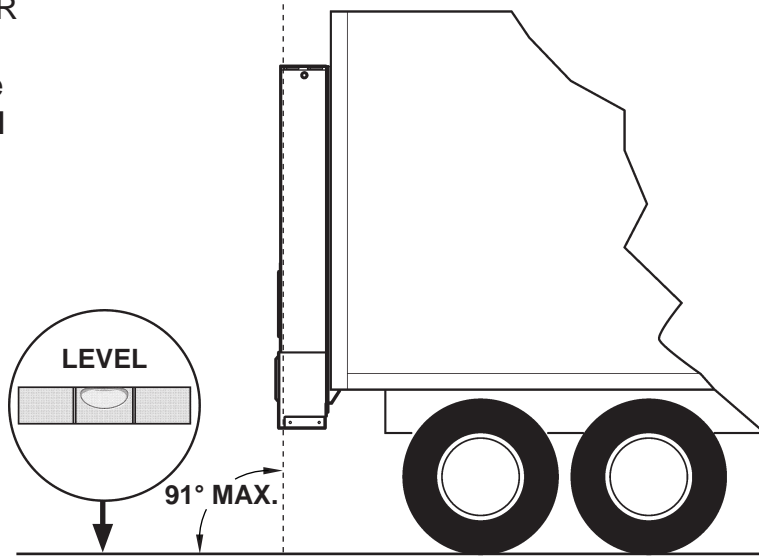

LIFTGATE INSTALLED ON VAN BODY (COLUMNS SHOWN PERPENDICULAR TO LEVEL GROUND)
FIG. 12-1

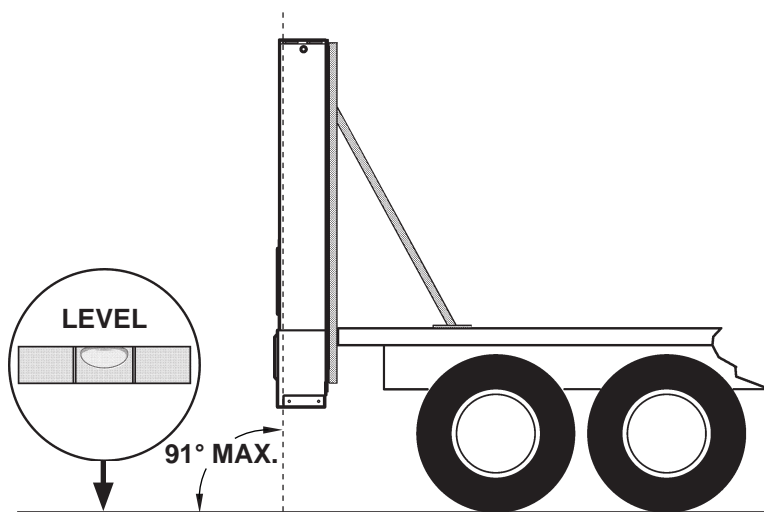

LIFTGATE INSTALLED ON FLAT BED (COLUMNS & SUPPORTS SHOWN PERPENDICULAR TO LEVEL GROUND)
FIG. 12-2

LIFTGATE INSTALLATION COMPONENTS

Each BMR Liftgate includes items shown in FIG. 13-1.

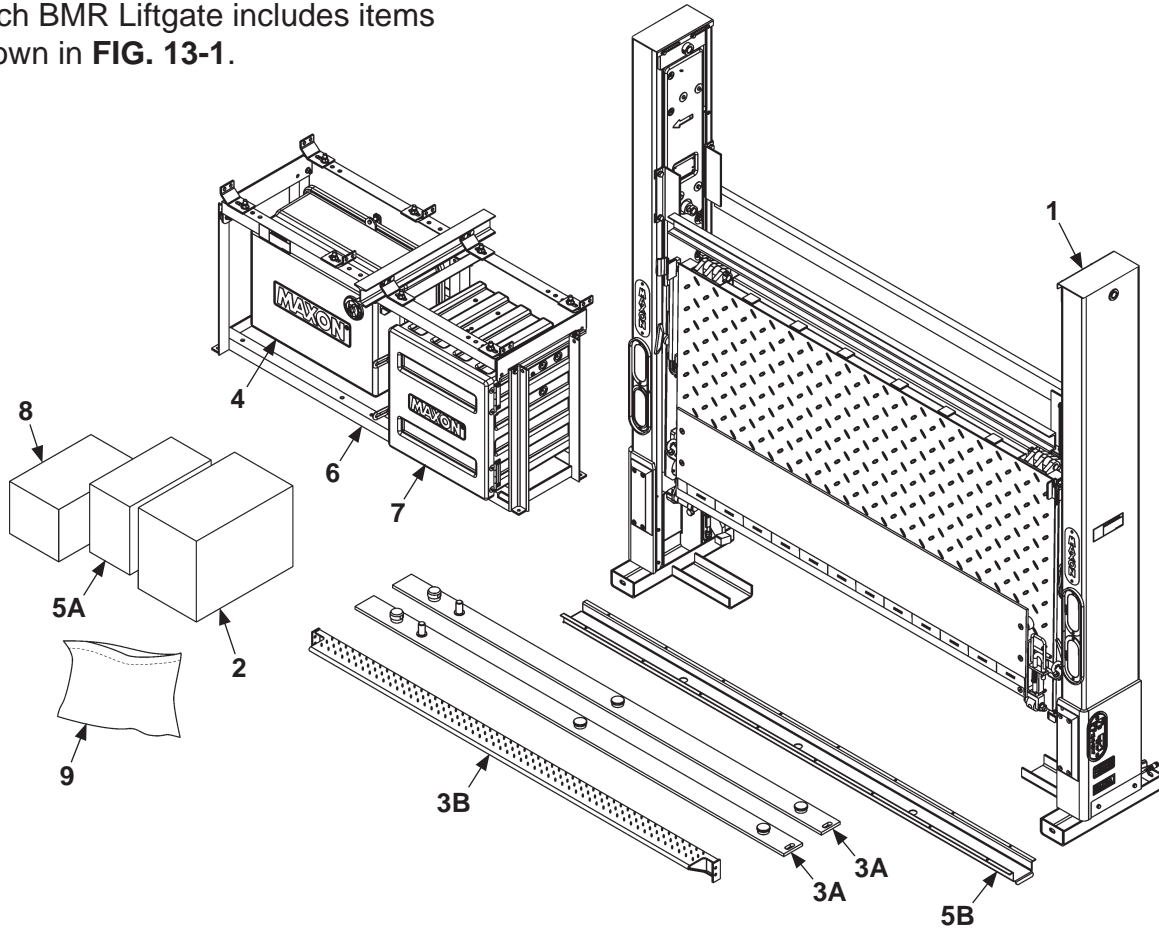

FIG. 13-1

DESCRIPTION	
1	BMR Liftgate
2	Hardware parts bag, mounting bracket parts bag, hydraulic lines & fittings, wiring harness, power cable, molded switch control box
3A	Mounting plate (bolt-on installation kit)
3B	Extension plate (bolt-on installation kit)
4	Pump box assembly
5A	Pump installation kit (3', 10', 15', 20', or 28')
5B	Channel guard (for 10', 15', 20' or 28' installation kits only)
6	Frame for pump box with optional battery box is shown. A shorter frame is also available for mounting single pump box or an optional battery box.
7	Battery box (optional)
8	Optional equipment
9	Instruction manuals and decals

TABLE 13-1

COMPONENTS

NOTE: Make sure you have components and parts before you start installing Liftgate. Compare parts in the part box and each kit box with packing list enclosed in each box. If parts and components are missing or incorrect, call:

Maxon Customer Service
Call (800) 227-4116 or
Send e-mail to cservice@maxonlift.com

BMR MODEL	MANUAL & DECAL KIT	BOLT-ON INSTALLATION KIT, STNL-STEEL	BOLT-ON INSTALLATION KIT, STEEL	BOLT-ON INSTALLATION KIT, PRIMER
BMR-35	288876-35	288875-11 (96" WIDE VEHICLE)	288875-01 (96" WIDE VEHICLE)	288875-21 (96" WIDE VEHICLE)
BMR-44	288876-44			
BMR-55	288876-55	288875-12 (102" WIDE VEHICLE)	288875-02 (102" WIDE VEHICLE)	288875-22 (102" WIDE VEHICLE)
BMR 66	288876-66			

TABLE 14-1

BMR MODEL	PART BOX	3 FT PUMP BOX INSTALL KIT	10 FT PUMP BOX INSTALL KIT	15 FT PUMP BOX INSTALL KIT	20 FT PUMP BOX INSTALL KIT	28 FT PUMP BOX INSTALL KIT
BMR-35 PD	296805-02 (WELD-ON)	288880-11	288880-12	288880-13	288880-14	288880-15
BMR-44 PD						
BMR-55 PD	296805-12 (BOLT-ON)					
BMR-66 PD						

TABLE 14-2

BMR MODEL	PART BOX	3 FT PUMP BOX INSTALL KIT	10 FT PUMP BOX INSTALL KIT	15 FT PUMP BOX INSTALL KIT	20 FT PUMP BOX INSTALL KIT	28 FT PUMP BOX INSTALL KIT
BMR-35 GD	296805-01 (WELD-ON)	288880-01	288880-02	288880-03	288880-04	288880-05
BMR-44 GD						
BMR-55 GD	296805-11 (BOLT-ON)					
BMR-66 GD						

TABLE 14-3

MAXON[®] 11921 Slauson Ave. Santa Fe Springs, CA. 90670 (800) 227-4116 FAX (888) 771-7713

COMPONENTS - Continued

BMR MODEL	OPTIONS							
	SINGLE PUMP ASSY	SECOND PUMP KIT	HYDRAULIC OIL UNIVIS HV1-13	FRAME, PUMP OR BATTERY BOXES	HEADER KIT (ADJUSTABLE)	HEADER KIT (RECESSED DOME LAMP)	DOME LAMP RECESSED - MOUNT	DOME TIMER SWITCH
BMR-35 GD BMR-44 GD BMR-55 GD BMR-66 GD	287670-12	287675-01	284098-01	288180-11G SINGLE FRAME (GALVANIZED)	289190-02 (GALVANIZED)	289188-11 (GALV, 96" WIDE VEHICLE) 289188-12 (GALV, 102" WIDE VEHICLE)	906589-01-100 (ONLY FOR HEADER KITS WITH RECESSED MOUNTS FOR DOME LAMPS)	3' REACH 295880-01
BMR-35 PD BMR-44 PD BMR-55 PD BMR-66 PD				287660-12				288810-11G DUAL FRAME 3 BATT BOX (GALVANIZED)

TABLE 15-1

BMR MODEL	OPTIONS						
	AUXILIARY CONTROL	HAND HELD CONTROL	CYCLE COUNTER	POWER & GROUND CABLES	CONSPICUITY (REFLECTIVE) TAPE	NON-SKID COATING	PUMP PRESSURE GAUGE
BMR-35 GD BMR-44 GD BMR-55 GD BMR-66 GD	289850-11	289840-01	289537-01	BASIC INSTALLATION 295263-01	295261-01	281531-100 (NOT FOR GALVANIZED PLATFORMS)	295895-01
BMR-35 PD BMR-44 PD BMR-55 PD BMR-66 PD				289850-12			

TABLE 15-2

MAXON[®] 11921 Slauson Ave. Santa Fe Springs, CA. 90670 (800) 227-4116 FAX (888) 771-7713

COMPONENTS - Continued

BMR MODEL	BATTERY BOX & CHARGING OPTIONS						
	BATTERY BOX (BATTERIES NOT INCLUDED)	BATTERY 12V HD AGM	BATTERY BOX MOUNTING FRAME	TRUCK CHARGE LINE	2/0 AWG CABLE TRUCK CHARGE LINE	TRAILER CHARGE LINE FOR USE WITHOUT TRAIL CHARGER	TRACTOR CHARGE LINE FOR USE WITH OR WITHOUT TRAIL CHARGER
BMR-35 BMR-44 BMR-55 BMR-66	2 BATTERIES 269560-01 2 BATTERIES (INCLUDES DC-DC CONVERTER) 289988-01 3 BATTERIES 269950-01 3 BATTERIES (INCLUDES DC-DC CONVERTER) 289988-02	267318-01	SINGLE GALV FRAME FOR 2 BATTERIES 287990-01G SINGLE GALV FRAME FOR 3 BATTERIES 287929-01G	280290	285860-01	SINGLE POLE 280275-01 DUAL POLE 280275-02 SINGLE/DUAL POLE FOR NOSE BOX 280275-06 1/0 AWG DUAL POLE WITH SINGLE NOSE BOX 280275-08	SINGLE POLE 280275-03 DUAL POLE 280275-04 SINGLE & DUAL POLE WITH ADAPTER 280275-05

TABLE 16-1

BMR MODEL	DIRECT TRAIL CHARGER OPTIONS			
	DIRECT WITH DUAL POLE CONNECTIONS	DIRECT, DUAL COMBINATION CONNECTIONS	DIRECT, 7-WAY CONNECTIONS	DIRECT, REFRIGERATED OR STRAIGHT TRUCK CONNECTIONS
BMR-35 BMR-44 BMR-55 BMR-66	295219-01 (DIRECT-01)	295220-01 (DIRECT-02)	295211-01 (DIRECT-03)	295972-01 (DIRECT-04)

TABLE 16-2

BMR MODEL	SELECT TRAIL CHARGER OPTIONS			
	SELECT WITH REFRIGERATED & DUAL POLE CONNECTIONS	SELECT WITH DUAL POLE & 7-WAY CONNECTIONS	SELECT WITH DUAL COMBINATION & 7-WAY CONNECTIONS	SELECT WITH DUAL COMBINATION, REFRIGERATED & 7-WAY CONNECTIONS
BMR-35 BMR-44 BMR-55 BMR-66	295210-01 (SELECT-21)	295217-01 (SELECT-24)	295218-01 (SELECT-25)	296170-01 (SELECT-32)

TABLE 16-3

BMR MODEL	MISCELLANEOUS OPTIONS		
	DIRECT / SELECT BYPASS	MANUAL HOLDER	BATTERY STATE OF CHARGE INDICATOR
BMR-35 BMR-44 BMR-55 BMR-66	295221-01 (BYPASSES TRAIL CHARGER OR DISCONNECTS BATTERIES FROM CHARGING SYSTEM)	286328-01 (INSTALLS IN BATTERY BOX)	908171-01-100 (INSTALLS ON BATTERY BOX)

TABLE 16-4

MAXON[®] 11921 Slauson Ave. Santa Fe Springs, CA. 90670 (800) 227-4116 FAX (888) 771-7713

STEP 1 - PREPARE VEHICLE IF REQUIRED

NOTE: Perform the following step for flatbed vehicle body only. If vehicle body is not a flatbed, skip this step.

NOTE: LH and RH supports must be perpendicular to level ground. See **VEHICLE REQUIREMENTS, INSTALLED LIFTGATE.**

NOTE: Materials for support framework are not provided with Liftgate.

⚠ WARNING

Recommended practices for welding on steel parts are contained in the current AWS (American Welding Society) D1.1 Structural Welding Code - Steel. Damage to Liftgate and/or vehicle, and personal injury can result from welds that are done incorrectly.

1. Fabricate framework, as shown in **FIGS. 17-1A, -1B & -1C**, to support Liftgate on a flatbed vehicle. Then, go to the next page for welding instructions.

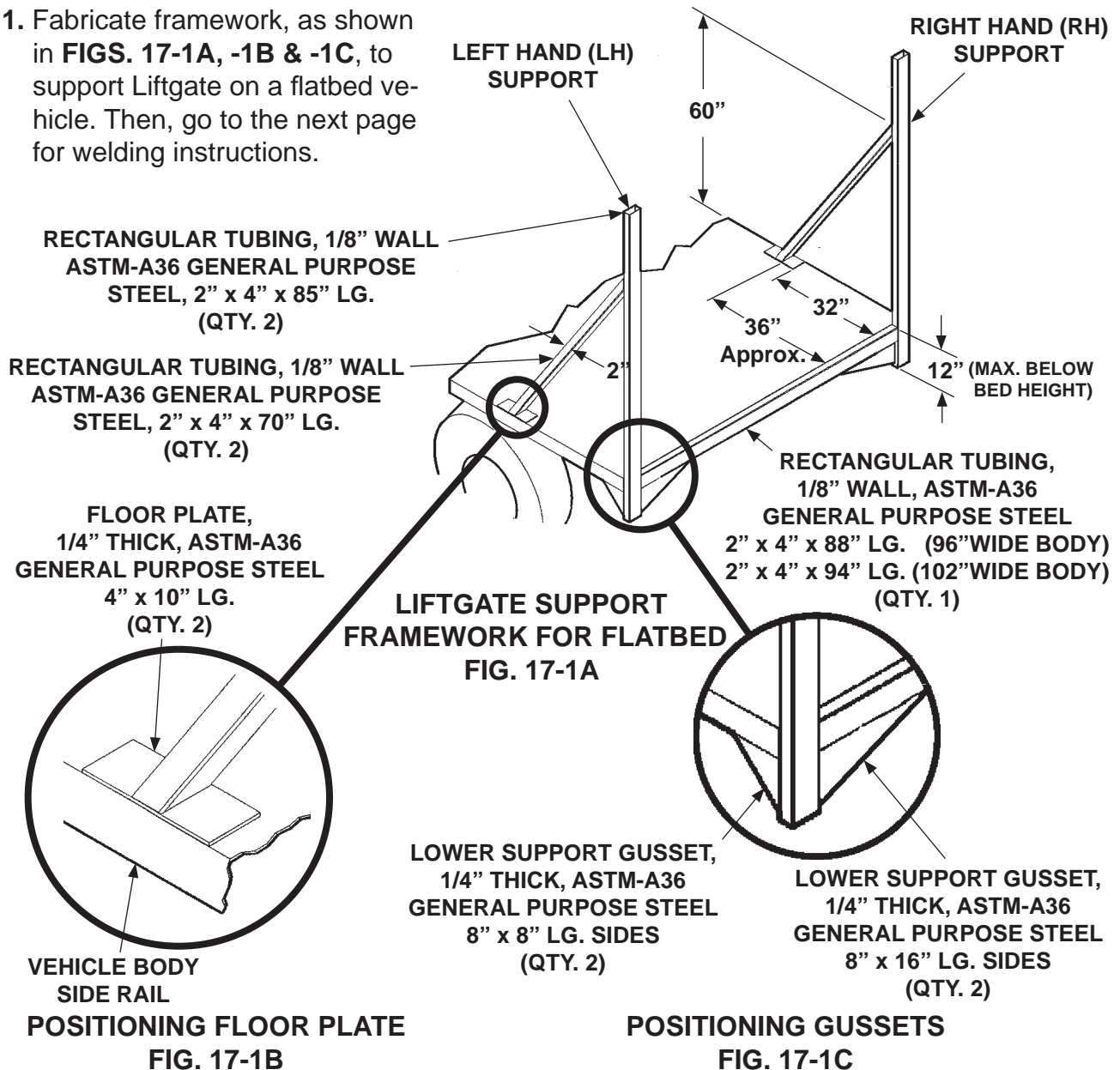

STEP 1 - PREPARE VEHICLE IF REQUIRED - Continued

2. Weld Liftgate supports, as shown in FIGS. 18-1A, -1B, -1C & -1D.

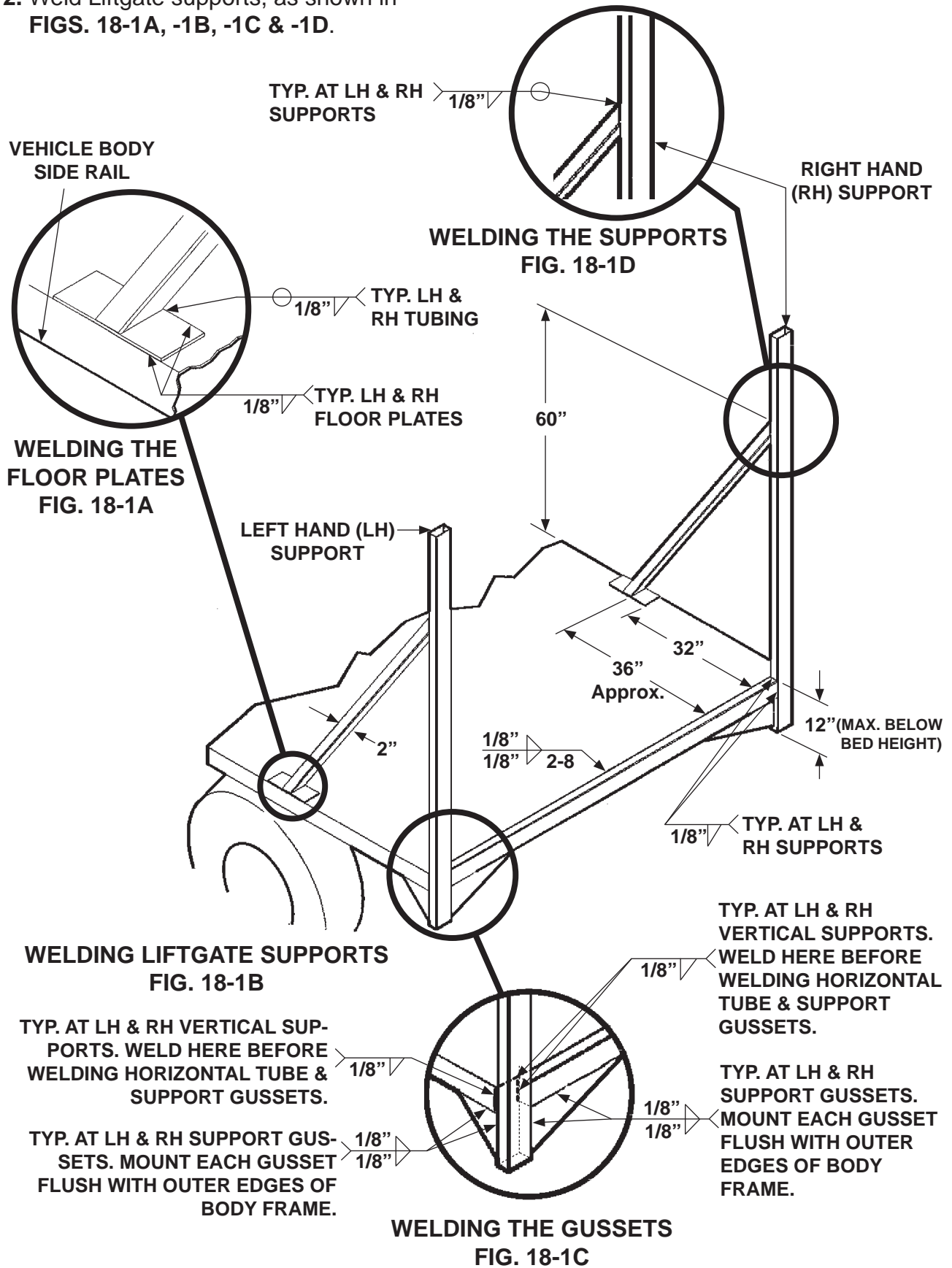

11921 Slauson Ave. Santa Fe Springs, CA. 90670 (800) 227-4116 FAX (888) 771-7713

MAXON

STEP 2 - CHOOSE METHOD OF INSTALLATION

NOTE: MAXON recommends pre-installing the extension plate and mounting plates on the vehicle body before installing the Liftgate.

NOTE: In methods 1 and 2, the extension plate and mounting plates come separate as part of the bolt-on installation kit.

Three methods for mounting a BMR Liftgate on a vehicle body are covered in this manual.

Method 1 - Column mounting plates and extension plate can be welded to vehicle body before bolting on the Liftgate (**FIG. 19-1**). Refer to the **PRE-INSTALL MOUNTING PLATES AND EXTENSION PLATE ON VEHICLE** instructions in **STEP 3**.

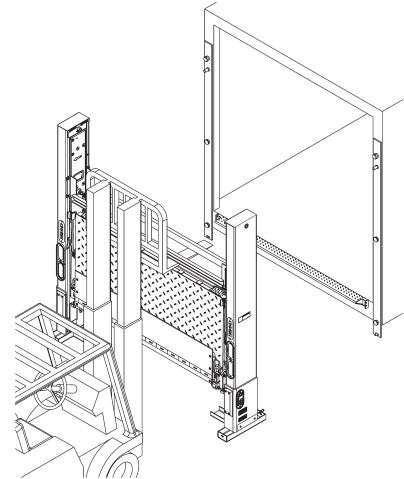

FIG. 19-1

Method 2 - Column mounting plates and extension plate can be bolted to liftgate before welding the Liftgate to vehicle (**FIG. 19-2**). Refer to the **PRE-INSTALL MOUNTING PLATES AND EXTENSION PLATE ON LIFTGATE** instructions in **STEP 3**.

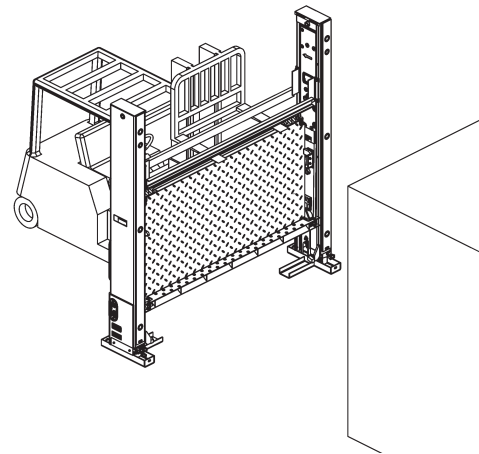

FIG. 19-2

Method 3 - Liftgate equipped with extension plate can be welded to vehicle body (**FIG. 19-3**). Refer to the **WELD LIFTGATE TO BODY** instructions in **STEP 3**.

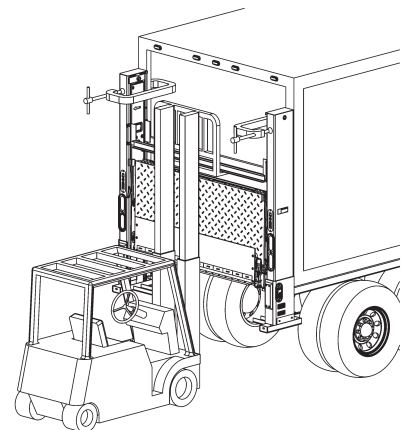

FIG. 19-3

STEP 3 - POSITION LIFTGATE

METHOD 1 - PRE-INSTALL MOUNTING PLATES AND EXTENSION PLATE ON VEHICLE

CAUTION

Some mild steel Liftgate mounting channels and extension plates are coated with a protective film and shipped unpainted. The film, if not removed for painting, can cause paint to separate from surface. Use hot soapy water and rinse water to remove the protective film before painting.

NOTE: Before installing the mounting plates and extension plate, use hot soapy water and rinse water to remove the protective film from these parts.

! WARNING

Recommended practices for welding on steel parts are contained in the current AWS (American Welding Society) D1.1 Structural Welding Code - Steel. Damage to Liftgate and/or vehicle, and personal injury can result from welds that are done incorrectly.

- Center the extension plate on rear of vehicle body and flush with top of the rear sill. Then, weld as shown in **FIGS. 20-1, 20-2 and 20-3.**

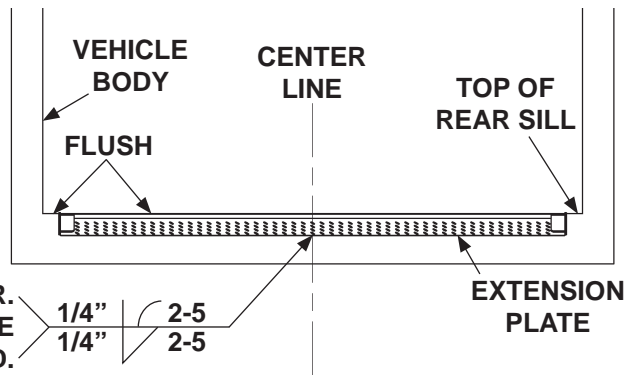

CENTERING EXTENSION PLATE ON 96" WIDE VEHICLE BODY
FIG. 20-1

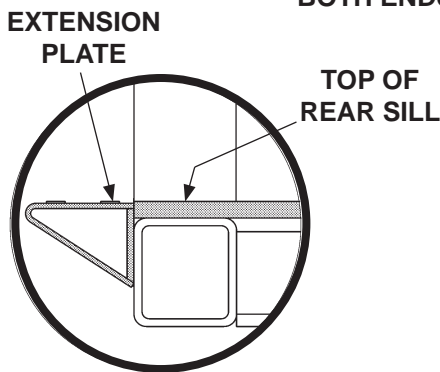

FLUSH EXTENSION PLATE
FIG. 20-3

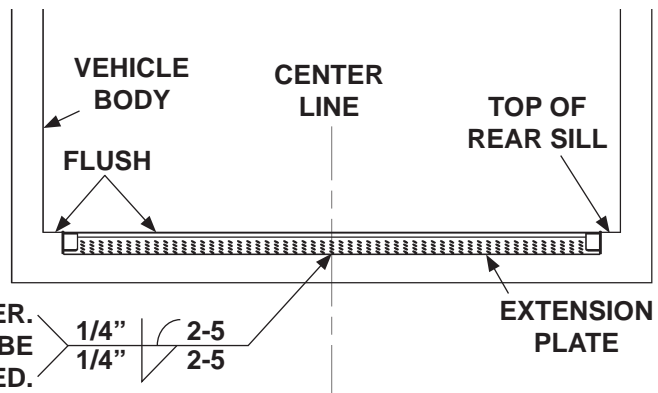

CENTERING EXTENSION PLATE ON 102" WIDE VEHICLE BODY
FIG. 20-2

STEP 3 - POSITION LIFTGATE - Continued

METHOD 1 - PRE-INSTALL MOUNTING PLATES AND EXTENSION PLATE ON VEHICLE - Continued

NOTE: Distance between extension plate and RH mounting bracket is measured from the inside edge of mounting plate as shown in illustration.

2. Position RH mounting plate as shown in FIGS. 21-1 and 21-1A.

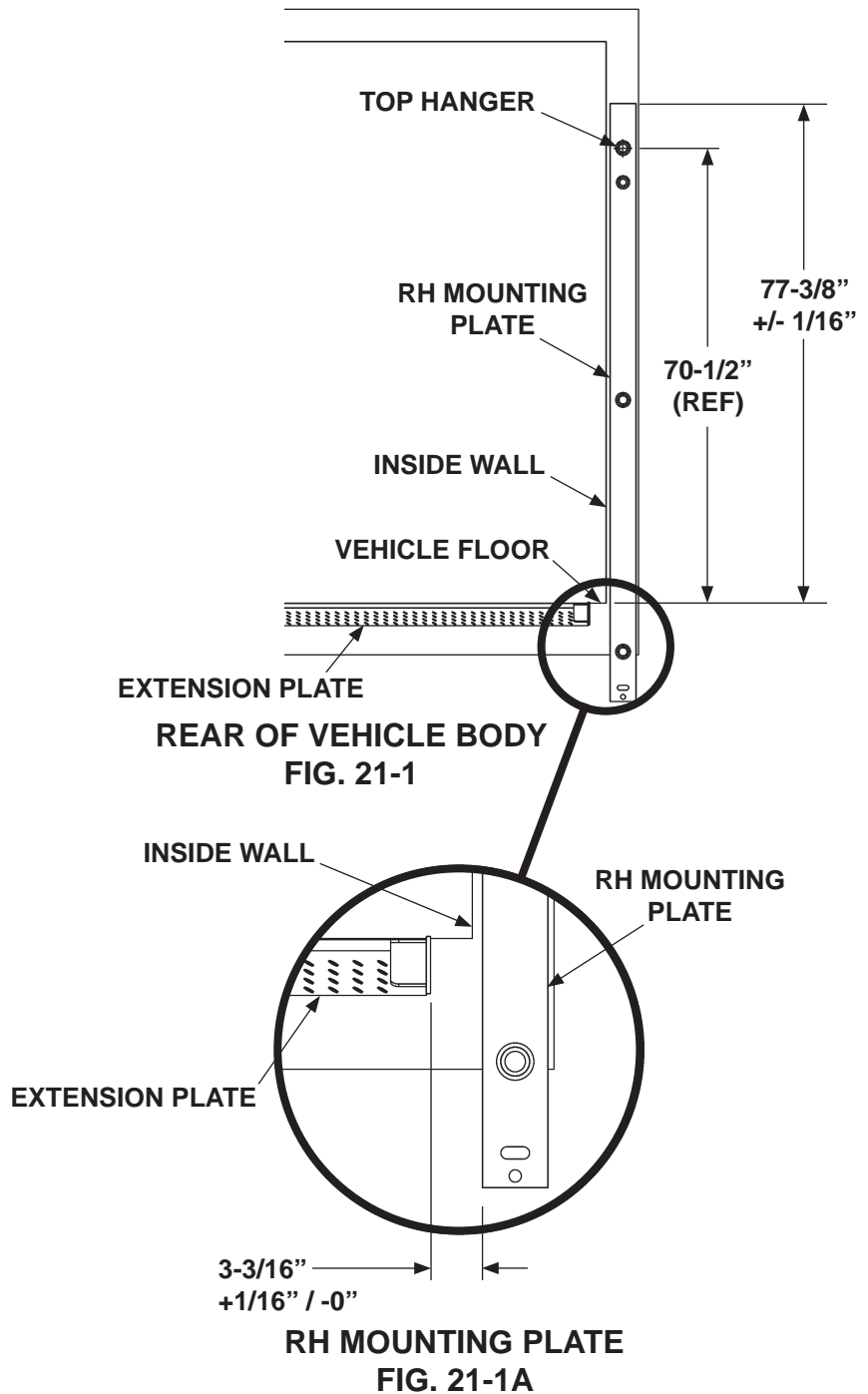

MAXON® 11921 Slauson Ave. Santa Fe Springs, CA. 90670 (800) 227-4116 FAX (888) 771-7713

STEP 3 - POSITION LIFTGATE - Continued

METHOD 1 - PRE-INSTALL MOUNTING PLATES AND EXTENSION PLATE ON VEHICLE - Continued

NOTE: Installer can use either set of dimensions shown in **FIG. 22-1** to install RH mounting plate. The first set of dimensions is taken from the center of each hanger, and the second set of dimensions is taken from the inner edge of the mounting plates.

3. Position LH mounting plate on vehicle body as shown in **FIGS. 22-1, 22-1A, and 22-1B.**

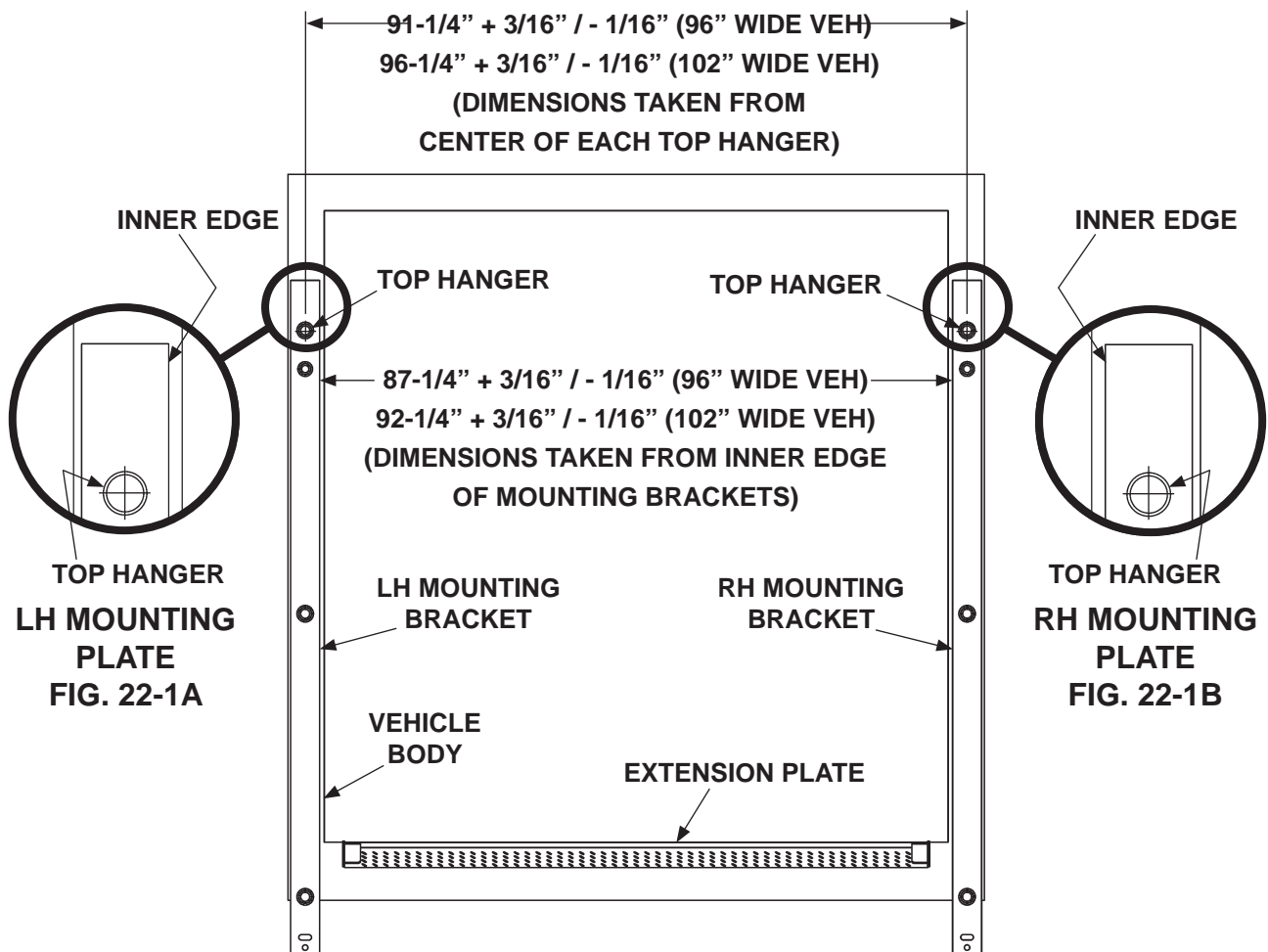

FIG. 22-1

STEP 3 - POSITION LIFTGATE - Continued

METHOD 1 - PRE-INSTALL MOUNTING PLATES AND EXTENSION PLATE ON VEHICLE - Continued

NOTE: Before welding mounting plates to vehicle frame, check squareness to make sure mounting plates are perpendicular to extension plate.

4. Check to make sure mounting plates are square and perpendicular to the extension plate by measuring dimensions **A** and **B** as shown in **FIG. 23-1**. Squareness is acceptable when dimensions **A** and **B** are within 1/8" of each other.
5. Weld RH mounting plate onto vehicle body (**FIG. 23-1**), then weld LH mounting plate onto vehicle body.

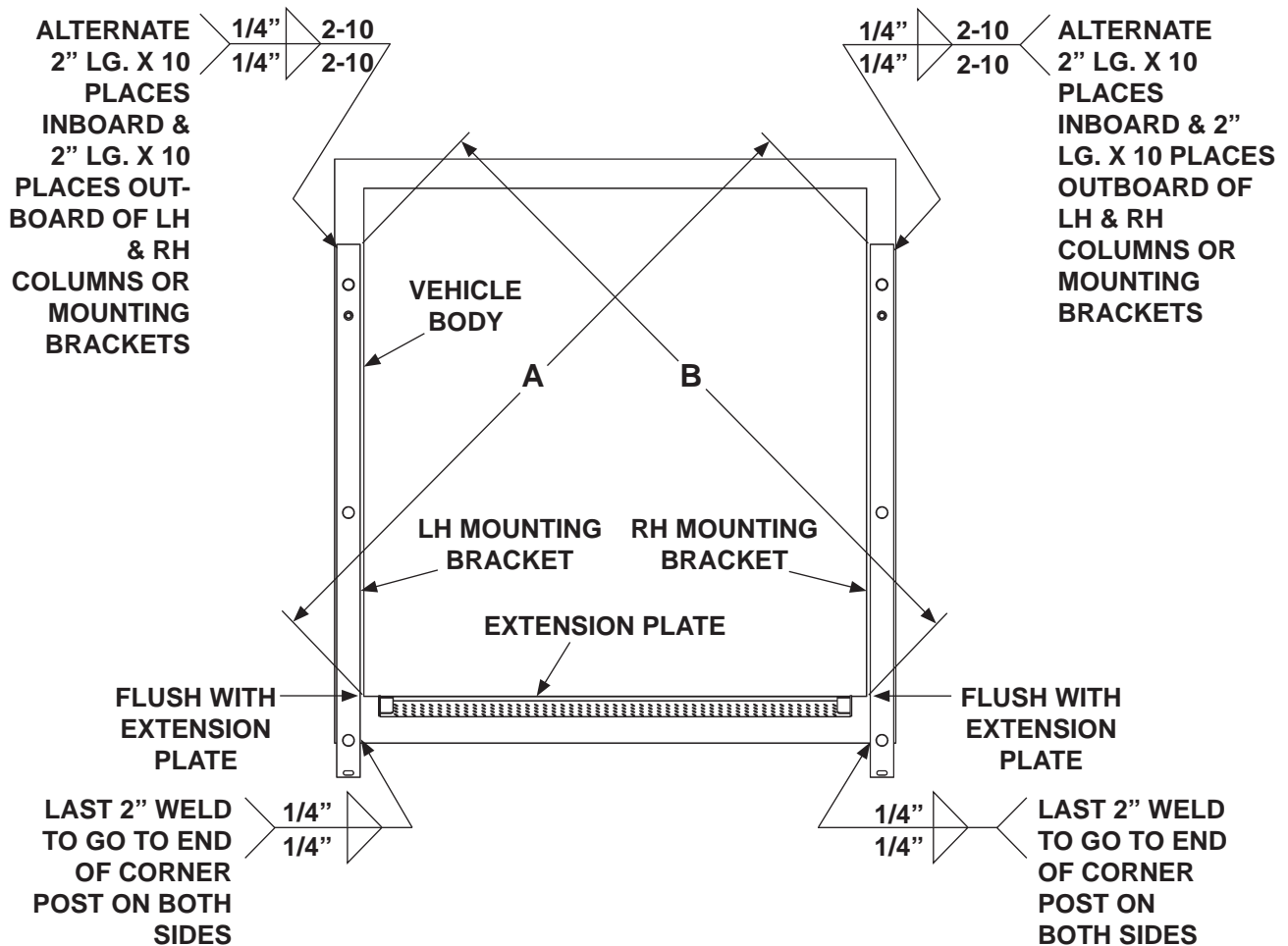

GO TO STEP 4.

STEP 3 - POSITION LIFTGATE - Continued

METHOD 2 - PRE-INSTALL MOUNTING PLATES AND EXTENSION PLATE ON LIFTGATE

NOTE: Save column cover hardware to reattach column cover later.

1. Remove screws, lock washers, flat washers and column cover from LH column (FIGS. 24-1 and 24-1A). Repeat for RH top column cover.
2. Attach mounting plates to liftgate columns by inserting hangers and mounting pin through matching slots in the columns (FIGS. 24-1 and 24-1B).

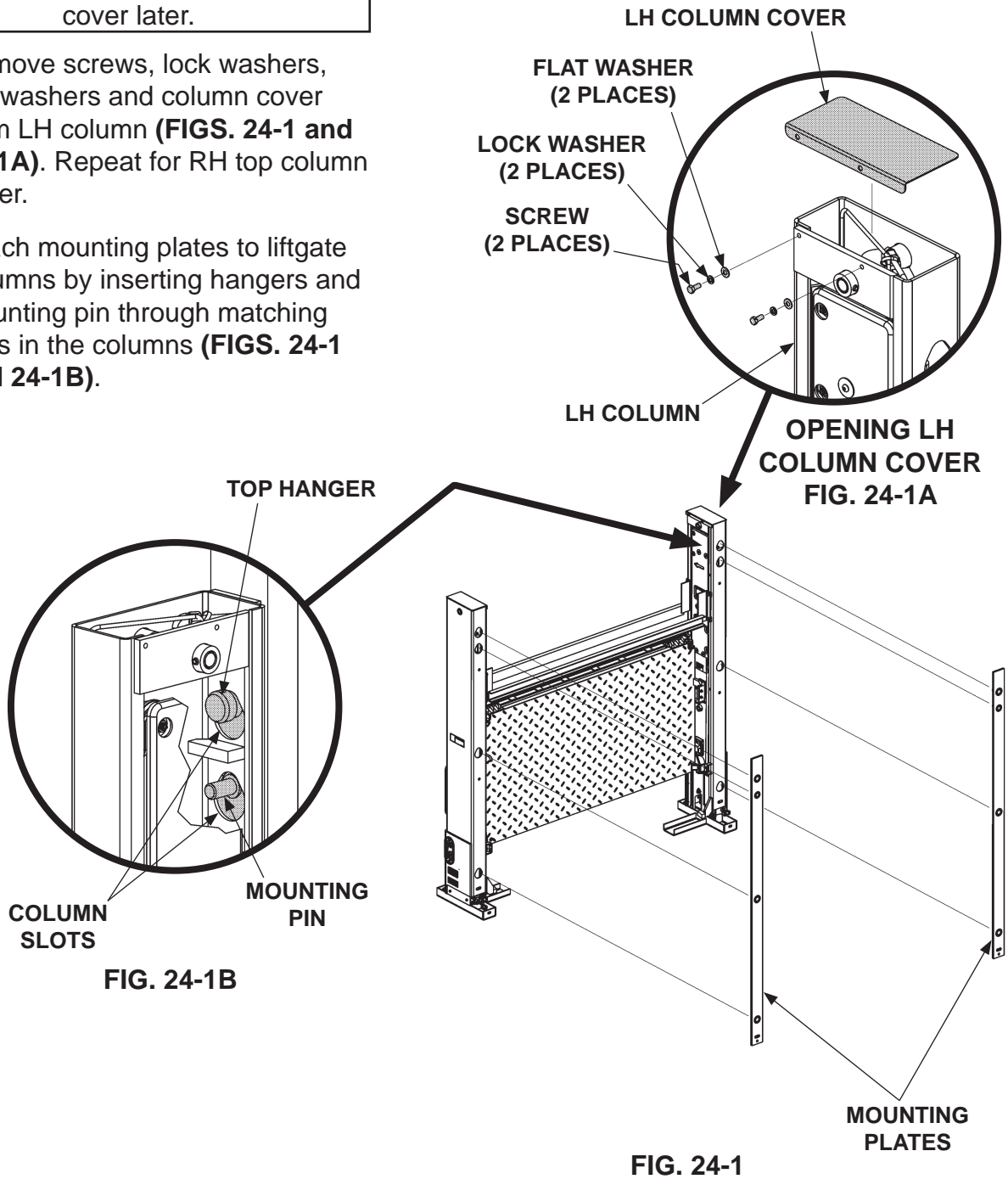

11921 Slauson Ave. Santa Fe Springs, CA. 90670 (800) 227-4116 FAX (888) 771-7713

MAXON

STEP 3 - POSITION LIFTGATE - Continued

METHOD 2 - PRE-INSTALL MOUNTING PLATES AND EXTENSION PLATE ON LIFTGATE - Continued

3. Get (2) hanger bolts from parts bag. Then look down into the top of LH column (**FIGS. 25-1 and 25-1A**) and locate top hanger. Repeat for RH column.
4. Insert (1) hanger bolt through top hanger in LH column (**FIGS. 25-1 and 25-1B**) and tighten against bolt guide until mounting plate is flush with column. Repeat for RH column.

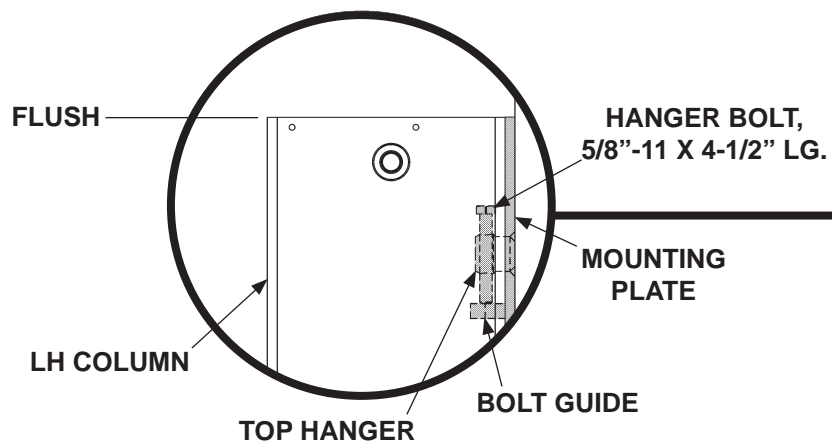
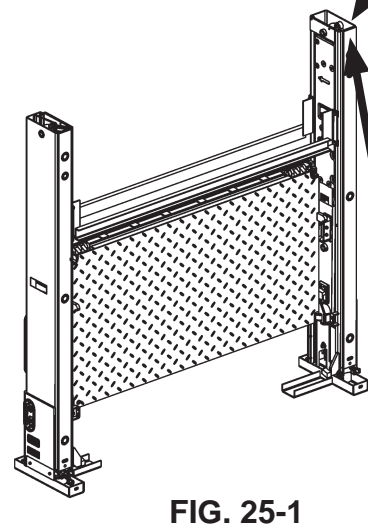
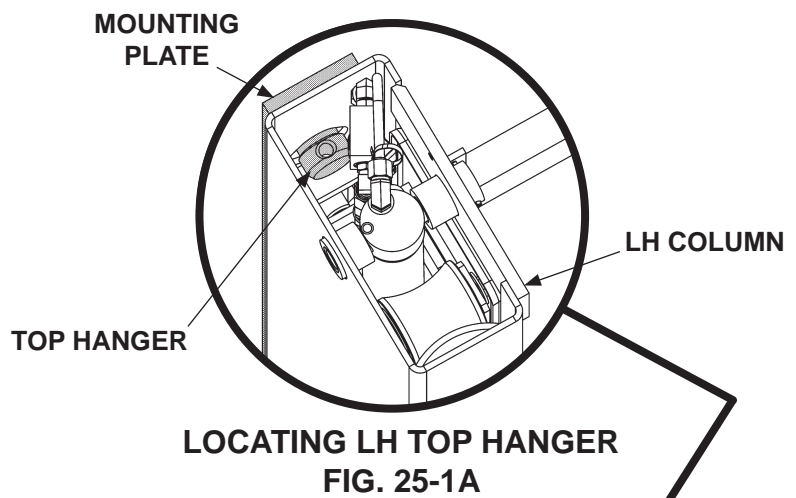

STEP 3 - POSITION LIFTGATE - Continued

METHOD 2 - PRE-INSTALL MOUNTING PLATES AND EXTENSION PLATE ON LIFTGATE - Continued

5. Remove (4) cap screws, (4) flat washers, (4) lock-nuts and (2) spacers from columns. Then, install (2) cap screws, (2) flat washers, (2) locknuts and (2) spacers in the LH column and extension plate (**FIGS. 26-1 and 26-1A**). Repeat for the RH column and extension plate.

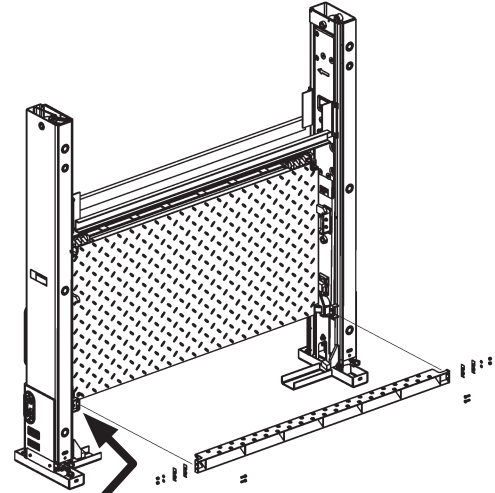

FIG. 26-1

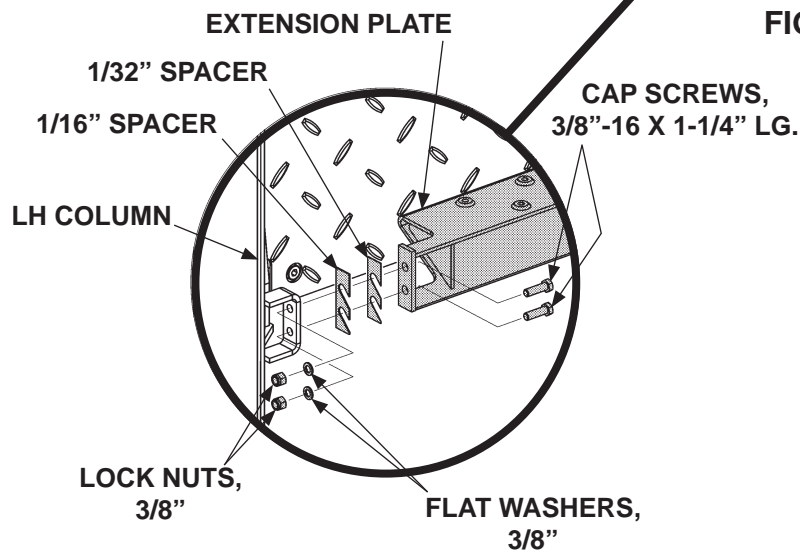

FIG. 26-1A

STEP 3 - POSITION LIFTGATE - Continued

METHOD 2 - PRE-INSTALL MOUNTING PLATES AND EXTENSION PLATE ON LIFTGATE - Continued

6. Measure the distance between outboard side of columns as shown in **FIG. 27-1**. If distance is less than 96.94" or 101.94", add spacers according to instructions below.

NOTE: Parts box contains quantity of one 1/16" and one 1/32" spacers for repositioning columns to 97" or 102" width outboard.

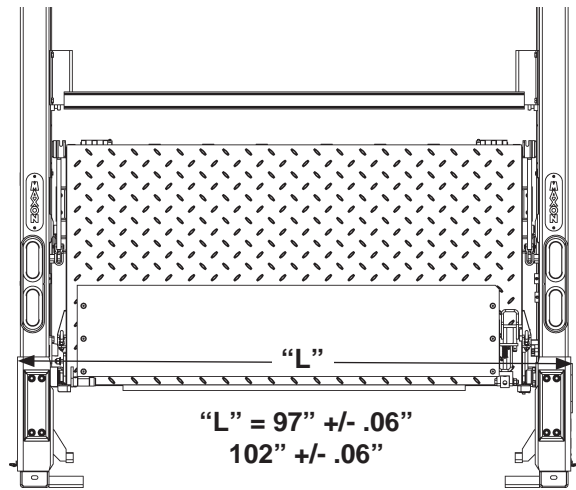

MEASURING OUTBOARD WIDTH AT COLUMN REINFORCEMENTS
FIG. 27-1

7. Add additional spacer(s) between extension plate and mounting bracket as follows to reposition columns to minimum 96.94" or 101.94" outboard width (**FIG. 27-1**). Unbolt one end of extension plate. Next, bolt additional spacers (as required) between extension plate and mounting bracket (**FIG. 27-2**) to bring outboard column width measurement to minimum specification. Repeat column measurement (**FIG. 27-1**). Add or remove spacers to get minimum 96.94" or 101.94" outboard width. When width is correct, torque extension plate nuts and bolts to 85 lb-ft (**FIG. 27-2**).

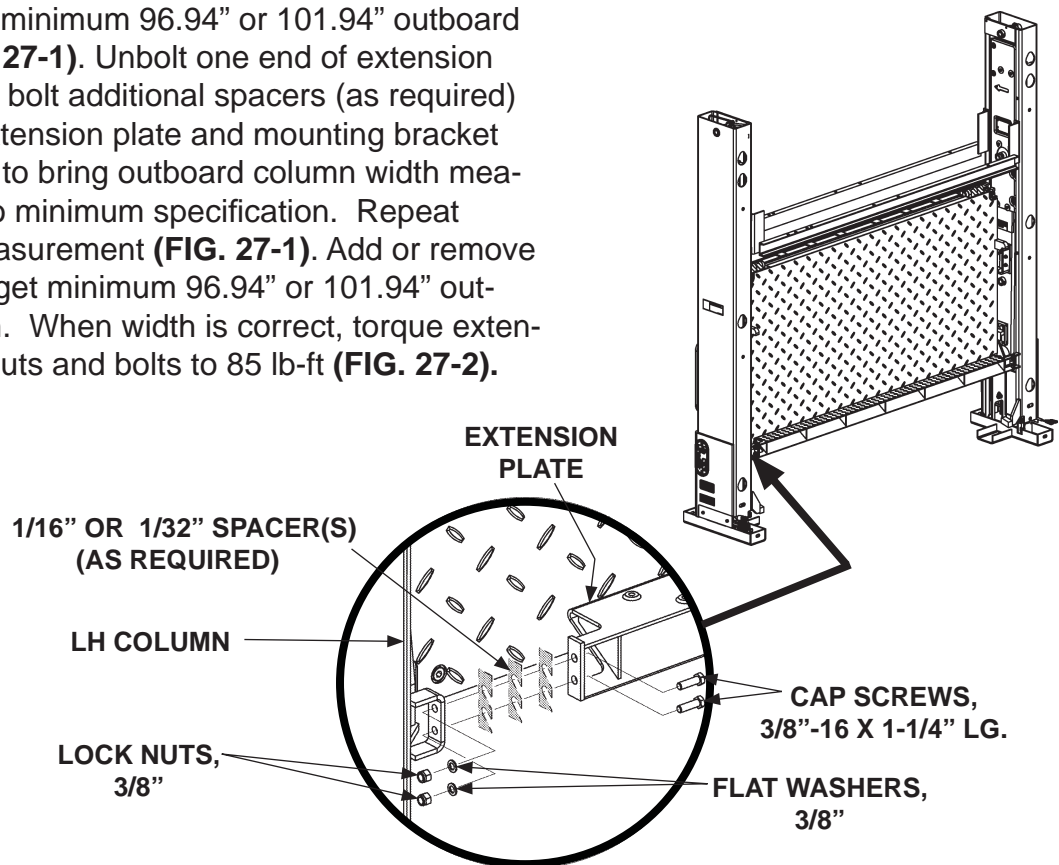

ADDING OR REMOVING SPACERS
FIG. 27-2

STEP 3 - POSITION LIFTGATE - Continued

METHOD 2 - PRE-INSTALL MOUNTING PLATES AND EXTENSION PLATE ON LIFTGATE - Continued

⚠ WARNING

Recommended practices for welding on steel parts are contained in the current AWS (American Welding Society) D1.1 Structural Welding Code - Steel. Damage to Liftgate and/or vehicle, and personal injury, can result from welds that are done incorrectly.

NOTE: Before welding extension plate to vehicle body, make sure:

- Inboard edge of extension plate is flush with the top of sill on vehicle body.
- Top surface of extension plate is level with the ground.

CAUTION

Comply with welding CAUTION decals on the LH & RH runners.

CAUTION

Electrical components and metal parts on this liftgate can be severely damaged by connecting an electric welder to liftgate at the wrong place. To prevent damage, always connect ground lead directly to the component being welded (e.g. runner, column, platform) and as close to the weld as possible.

P/N 260293

8. Weld 2 pieces of 10" X 2" angle stock to the top surface of the extension plate near the LH column as shown in **FIGS. 28-1 and 28-1A**. Repeat for RH column. The angle stock helps keep extension plate flush with top of vehicle bed while installing Liftgate.

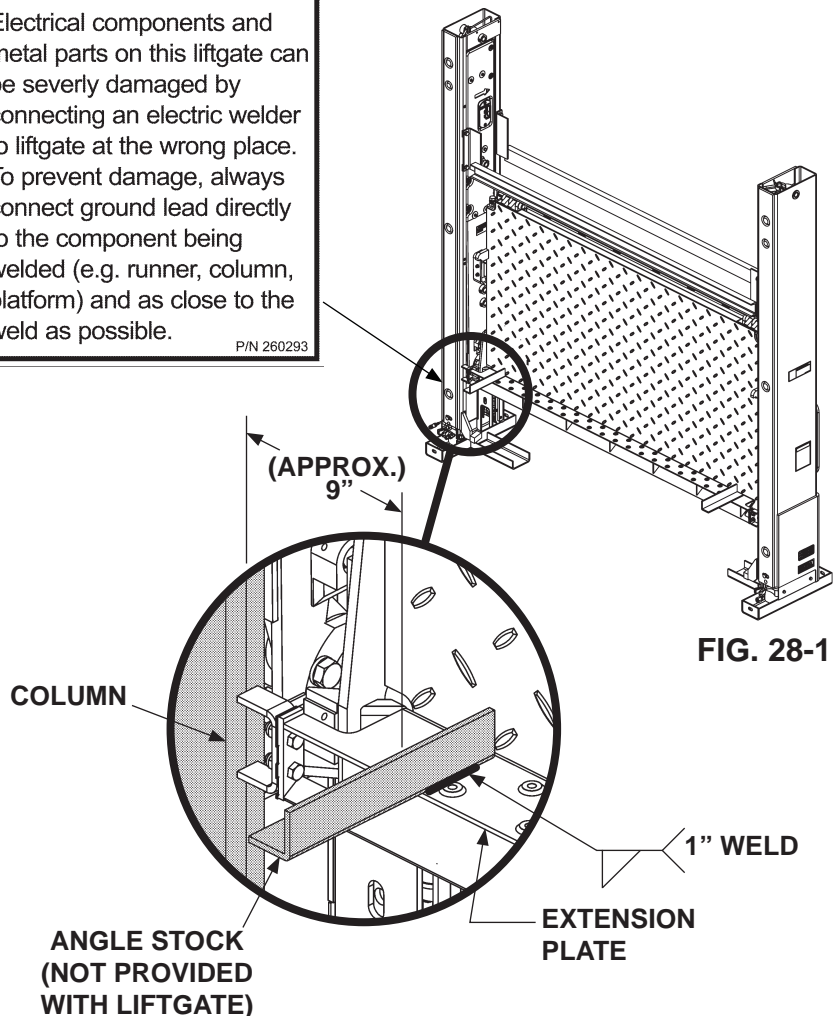

FIG. 28-1

FIG. 28-1A

STEP 3 - POSITION LIFTGATE - Continued

METHOD 2 - PRE-INSTALL MOUNTING PLATES AND EXTENSION PLATE ON LIFTGATE - Continued

9. Use overhead hoist or forklift to center Liftgate against the vehicle (**FIG. 29-1**). Let angle stock, welded to extension plate, rest on the top surface of the vehicle bed.
10. Clamp top of each column to vehicle body to prevent gap (**FIG. 29-1**).
11. Weld the RH and LH columns to vehicle body as shown in **FIG. 29-1**.
12. Remove clamp from each of the columns. Then, move forklift away from work area.

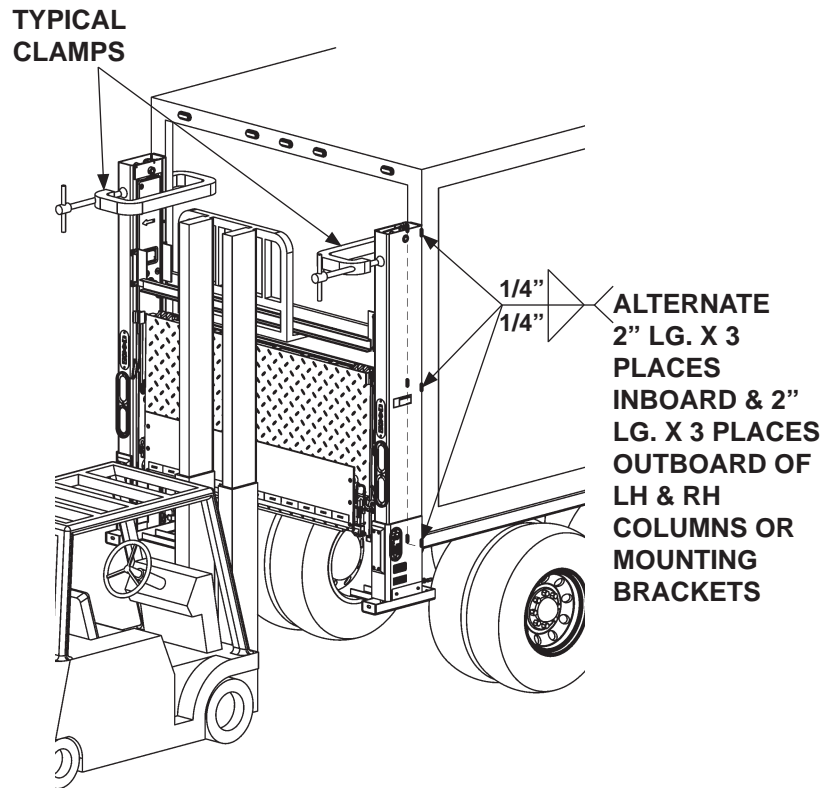

WELDING LIFTGATE TO
VEHICLE
FIG. 29-1

GO TO STEP 5.

STEP 3 - POSITION LIFTGATE - Continued

METHOD 3 - WELD LIFTGATE TO BODY

⚠ WARNING

Recommended practices for welding on steel parts are contained in the current AWS (American Welding Society) D1.1 Structural Welding Code - Steel. Damage to Liftgate and/or vehicle, and personal injury, can result from welds that are done incorrectly.

NOTE: Before welding extension plate to vehicle body, make sure:

- Inboard edge of extension plate is flush with the top of sill on vehicle body.
- Top surface of extension plate is level with the ground.

CAUTION

Comply with welding CAUTION decals on the LH & RH runners.

CAUTION

Electrical components and metal parts on this liftgate can be severely damaged by connecting an electric welder to liftgate at the wrong place. To prevent damage, always connect ground lead directly to the component being welded (e.g. runner, column, platform) and as close to the weld as possible.

P/N 260293

1. Weld 2 pieces of 10" X 2" angle stock to the top surface of the extension plate near the LH column as shown in **FIGS. 30-1 and 30-1A**. Repeat for RH column. The angle stock helps keep extension plate flush with top of vehicle bed while installing Liftgate.

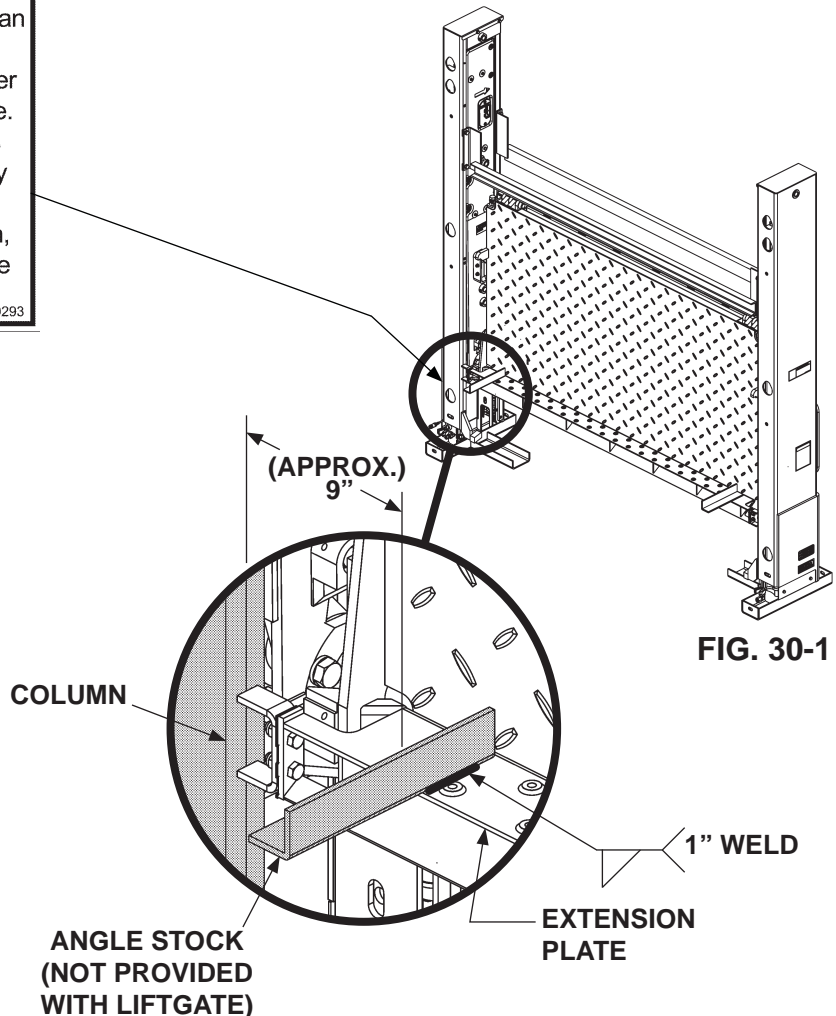

FIG. 30-1A

FIG. 30-1

STEP 3 - POSITION LIFTGATE - Continued

METHOD 3 - WELD LIFTGATE TO BODY - Continued

2. Use overhead hoist or forklift to center Lift-gate against the vehicle (**FIG. 31-1**). Let angle stock, welded to extension plate, rest on the top surface of the vehicle bed.
3. Clamp top of each column to vehicle body to prevent gap (**FIG. 31-1**).

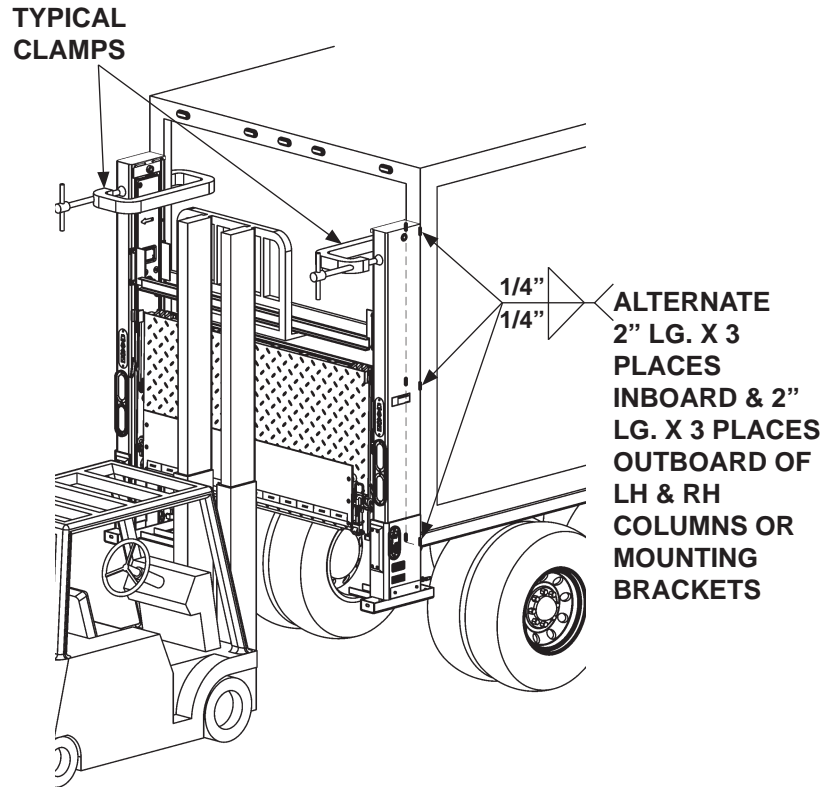

4. Weld the RH and LH columns to vehicle body as shown in **FIG. 31-1**.
5. Remove clamp from each of the columns. Then, move forklift away from work area.

**WELDING LIFTGATE TO
VEHICLE
FIG. 31-1**

GO TO STEP 5.

STEP 4 - BOLT LIFTGATE TO VEHICLE

METHOD 1 - PRE-INSTALLED MOUNTING PLATES & EXTENSION PLATE ON VEHICLE

NOTE: Save all hardware to re-attach column cover and extension plate.

1. Remove screws, lock washers, flat washers and top column cover from LH column (**FIGS. 32-1 and 32-1A**). Repeat for RH top column cover.
2. Remove (2) cap screws, flat washers, locknuts and spacers from LH column and extension plate (**FIGS. 32-1 and 32-1B**). Repeat for RH column and extension plate.

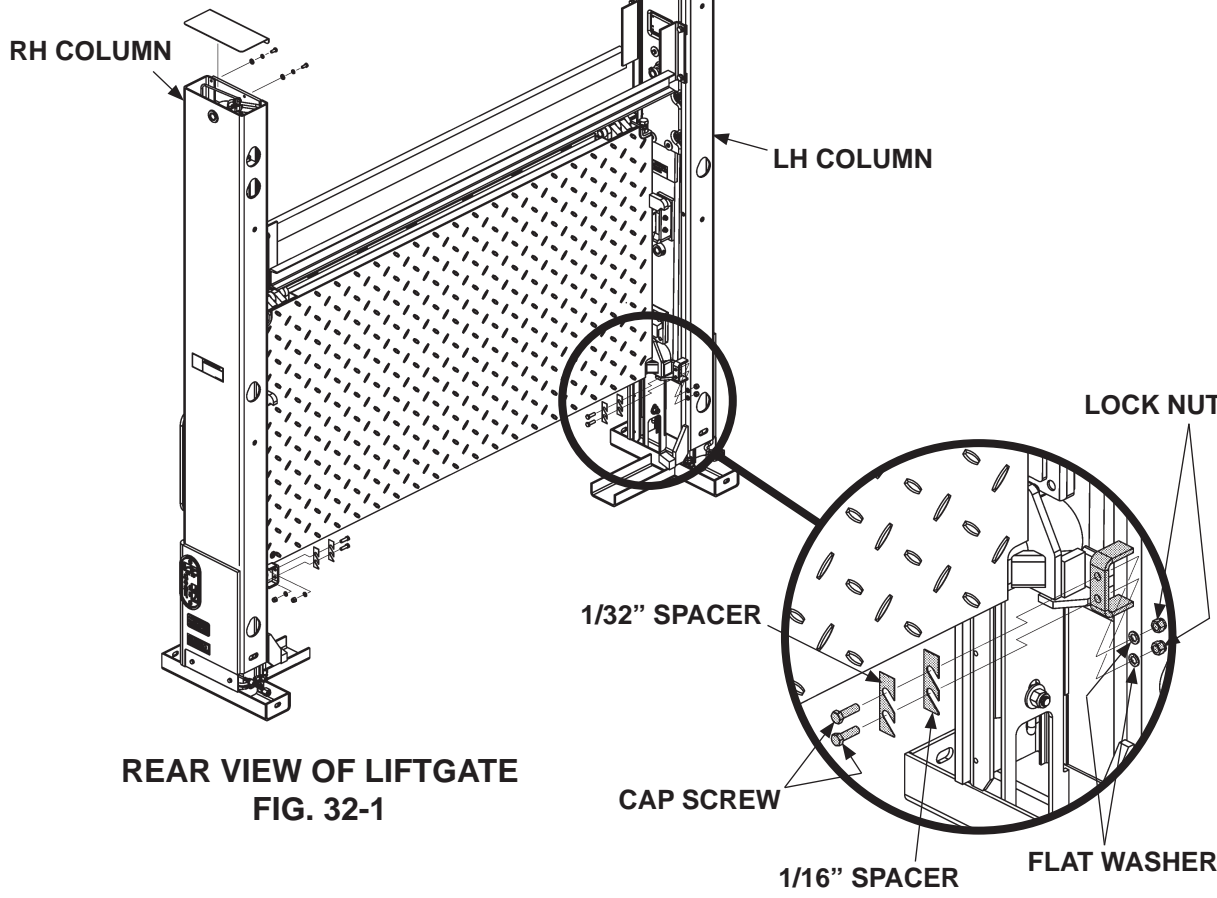
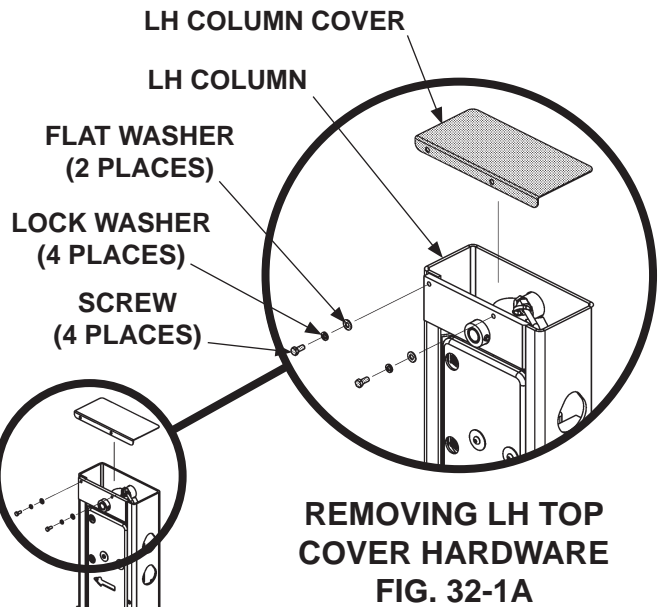

11921 Slauson Ave. Santa Fe Springs, CA. 90670 (800) 227-4116 FAX (888) 771-7713

MAXON®

STEP 4 - BOLT LIFTGATE TO VEHICLE - Continued

METHOD 1 - PRE-INSTALLED MOUNTING PLATES & EXTENSION PLATE ON VEHICLE - Continued

NOTE: If the rear of the vehicle & Liftgate mounting plates are galvanized, make sure:

- Bolts are removed from top hanger
- Bolt & cover are removed from hanger lock

3. Check if the Liftgate mounting plates and rear of vehicle are galvanized (**FIG. 33-1**). If galvanized, remove 2 bolts from top hanger on the RH mounting plate (**FIG. 33-1**). Then, remove screw and cover from hanger lock (**FIG. 33-1**). Repeat for LH mounting plate.

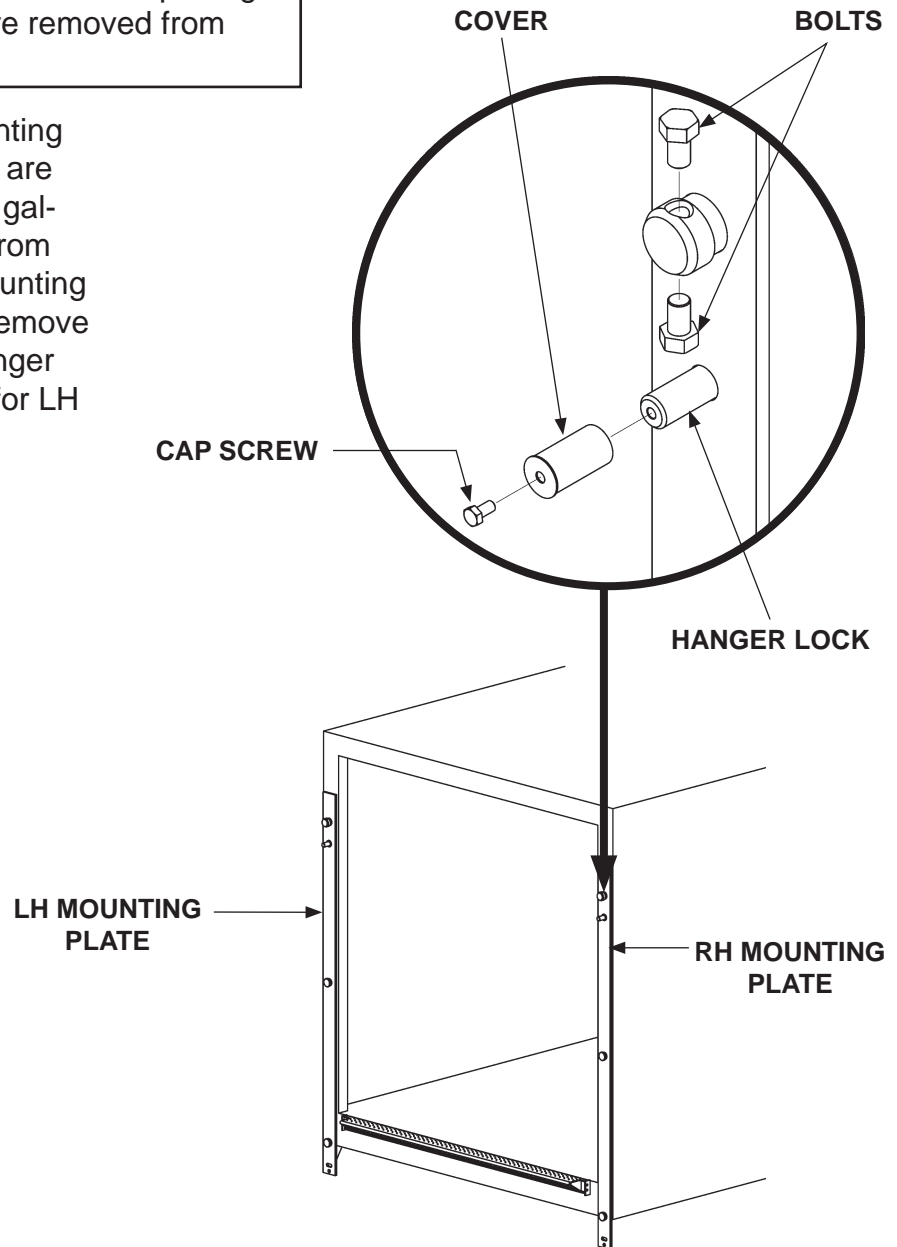

LIFTGATE MOUNTING PLATES
FIG. 33-1

STEP 4 - BOLT LIFTGATE TO VEHICLE - Continued

METHOD 1 - PRE-INSTALL MOUNTING PLATES AND EXTENSION PLATE ON VEHICLE - Continued

⚠ WARNING

Do not remove forklift until after top hanger bolts are tightened as shown in FIGS. 36-1 and 36-1B. Removing forklift before cap screws are tightened may cause liftgate to lift off the hangers when pressurizing and fall down, which can result damage to liftgate, vehicle and/or personal injury.

4. Hang liftgate on the mounting plates by inserting hangers into hanger slots (FIGS. 34-1 and 34-2).

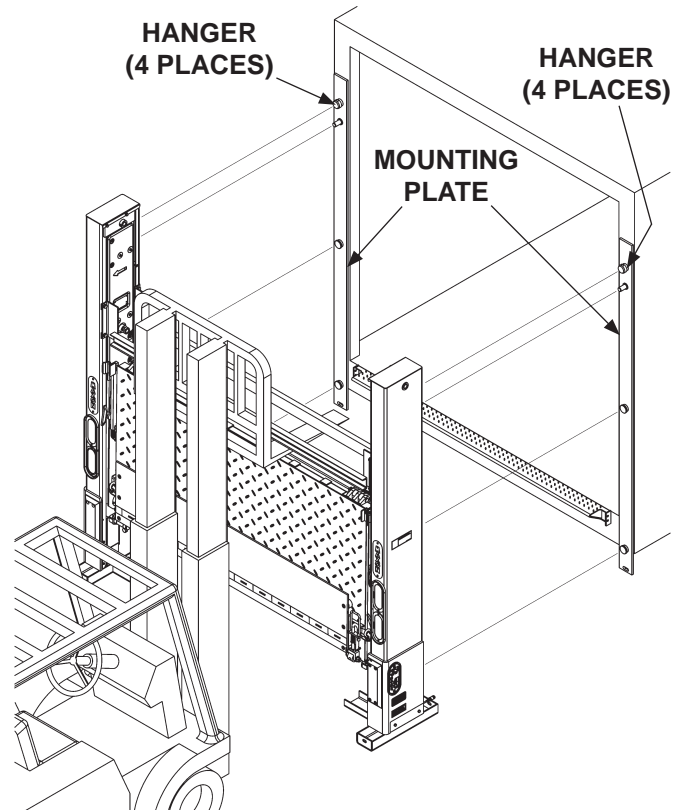

**HANGING LIFTGATE
FIG. 34-1**

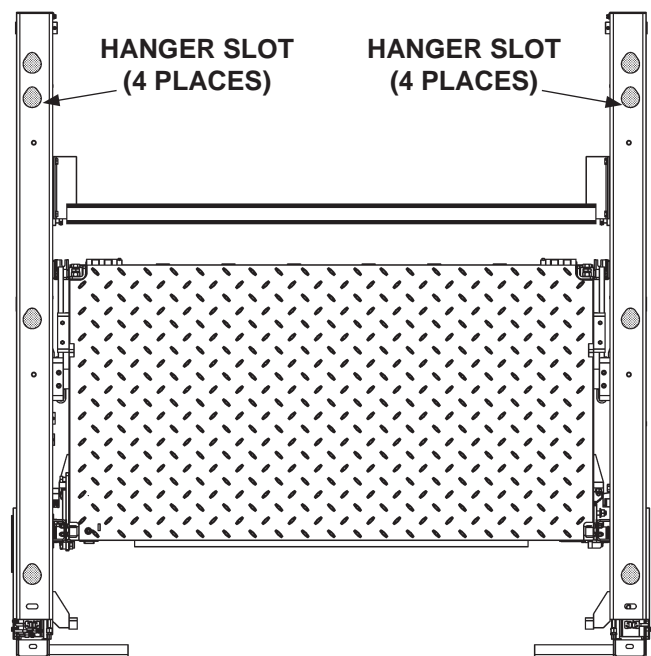

**REAR VIEW OF LIFTGATE
FIG. 34-2**

STEP 4 - BOLT LIFTGATE TO VEHICLE - Continued

METHOD 1 - PRE-INSTALL MOUNTING PLATES AND EXTENSION PLATE ON VEHICLE - Continued

⚠ WARNING

Do not remove forklift until after top hanger bolts are tightened as shown in FIGS. FIGS. 36-1 and 36-1B. Removing forklift before cap screws are tightened may cause liftgate to lift off the hangers when pressurizing and fall down, which can result damage to liftgate, vehicle and/or personal injury.

5. Slightly loosen support channel cap screws on the LH column (FIGS. 35-1 and 35-1A) to allow column slots to sit on top hangers and mounting pins (FIG. 35-1B). Repeat for RH column.

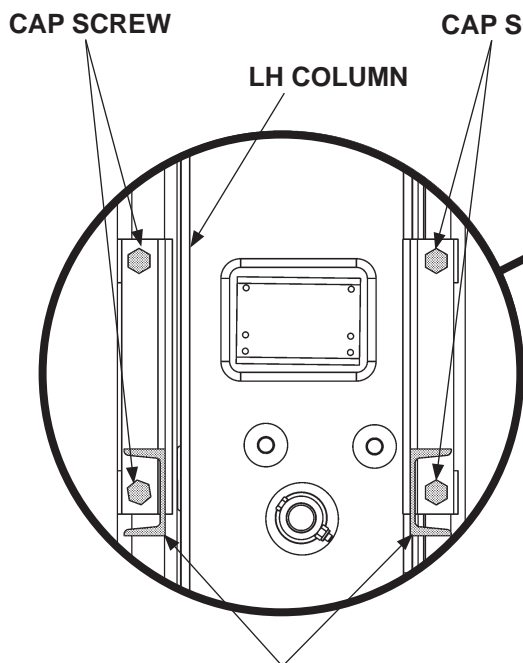

SUPPORT CHANNEL
LOOSENING LH
SUPPORT CHANNELS
FIG. 35-1A

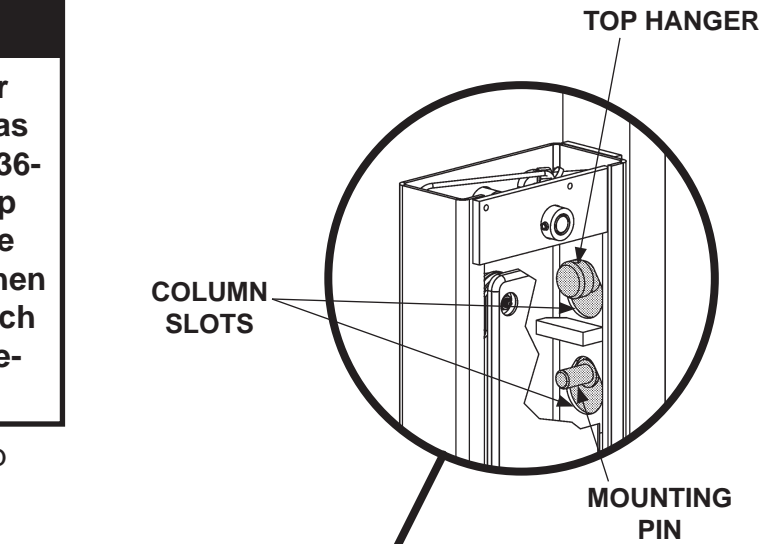

FIG. 35-1B

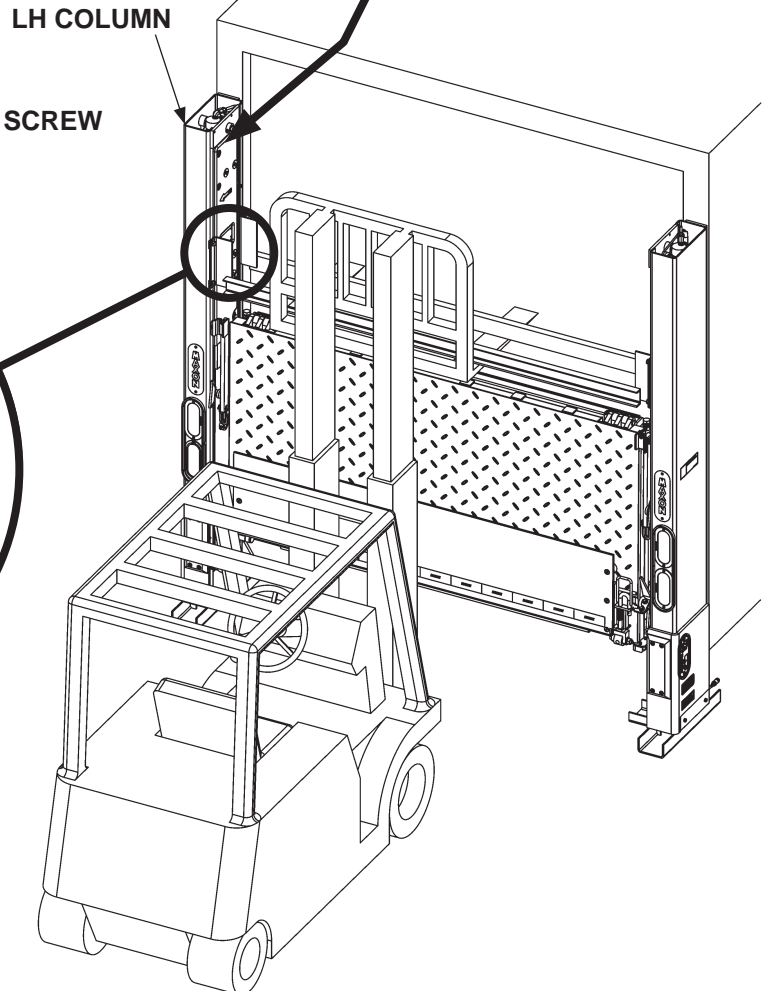

FIG. 35-1

STEP 4 - BOLT LIFTGATE TO VEHICLE - Continued

METHOD 1 - PRE-INSTALL MOUNTING PLATES AND EXTENSION PLATE ON VEHICLE - Continued

⚠ WARNING

Do not remove forklift until after top hanger bolts are tightened as shown in FIGS. 36-1 and 36-1B. Removing forklift before cap screws are tightened may cause liftgate to lift off the hangers when pressurizing and fall down, which can result damage to liftgate, vehicle and/or personal injury.

6. Get (2) hanger bolts from parts bag. Then look down into the top of LH column (FIGS. 36-1 and 36-1A) and locate top hanger.
7. Insert (1) hanger bolt through top hanger in LH column (FIGS. 36-1 and 36-1B) and tighten against bolt guide until mounting plate is flush with column. Repeat for RH column.
8. Remove forklift.

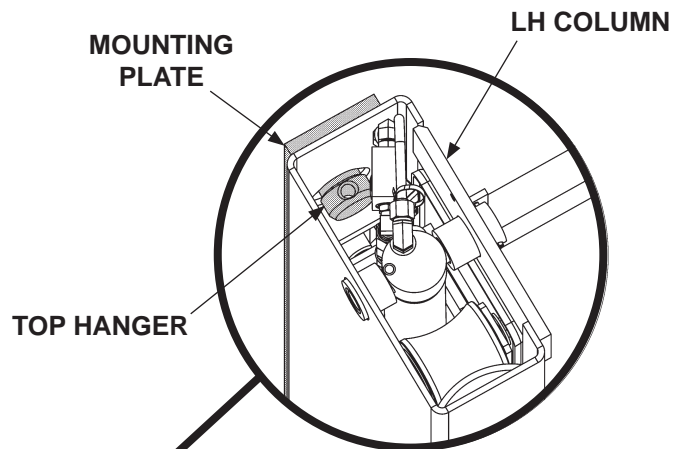

**LOCATING LH TOP HANGER
FIG. 36-1A**

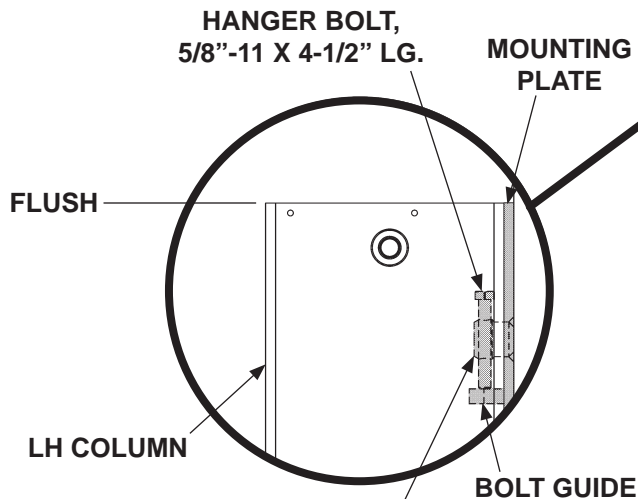

**INSERTING CAP SCREW
INTO LH TOP HANGER
FIG. 36-1B**

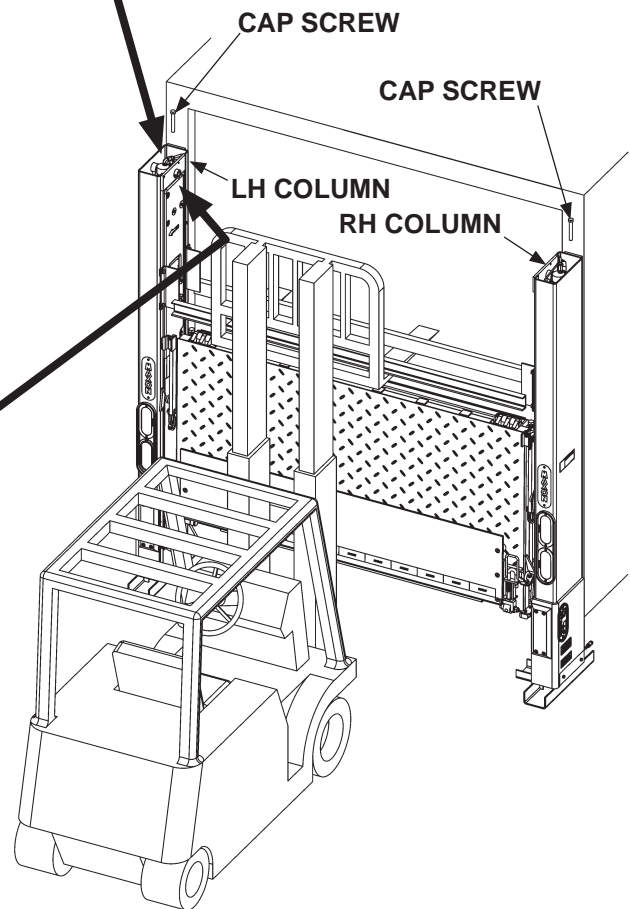
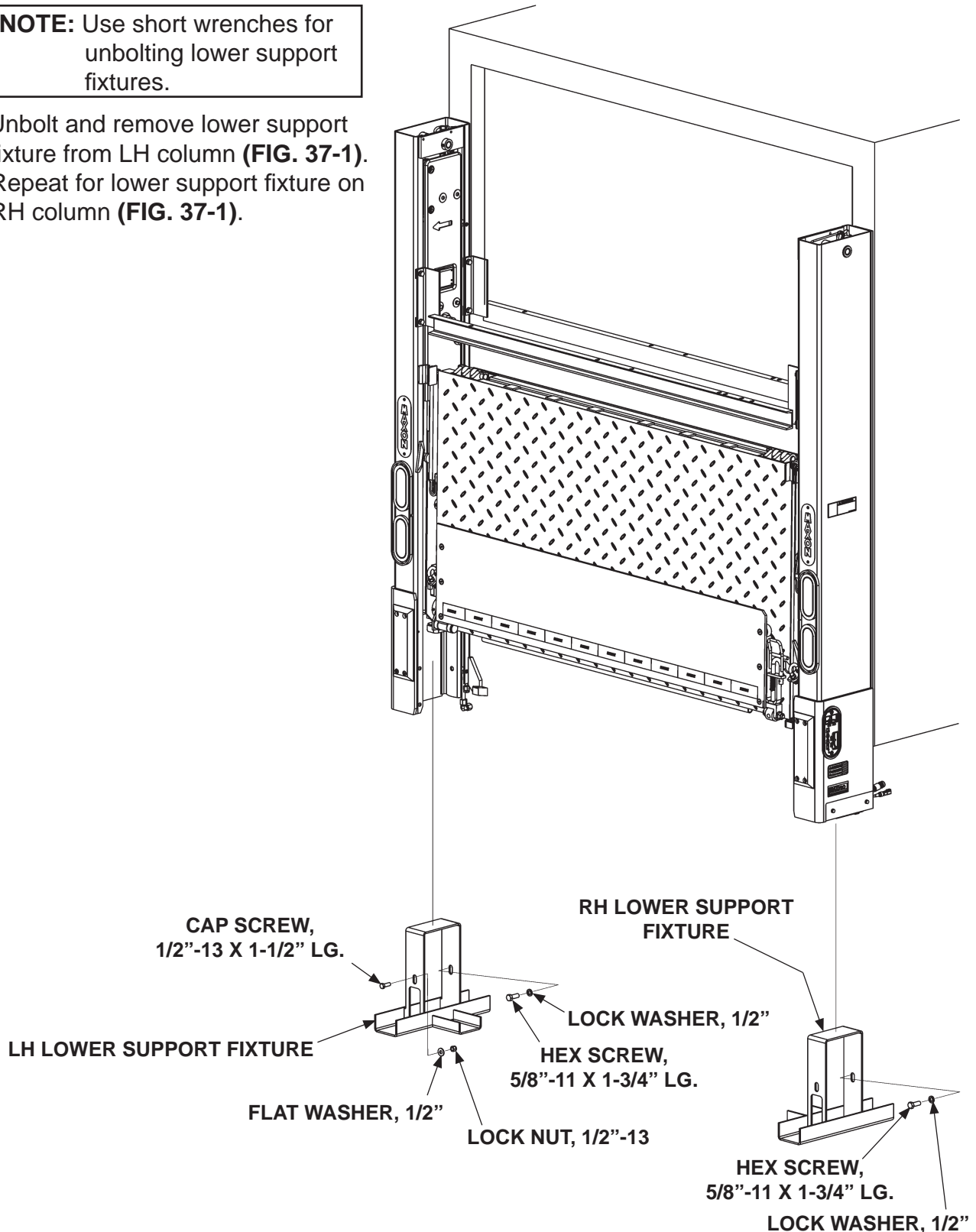

FIG. 36-1

STEP 5 - REMOVE LOWER SUPPORT FIXTURES

NOTE: Use short wrenches for unbolting lower support fixtures.

Unbolt and remove lower support fixture from LH column (**FIG. 37-1**). Repeat for lower support fixture on RH column (**FIG. 37-1**).



REMOVING LOWER SUPPORT FIXTURES
FIG. 37-1

STEP 6 - POSITION PUMP BOX FRAME

NOTE: Make sure pump box is closer to Liftgate than battery box (if installed) and pump box cover opens toward curb-side of vehicle. Also, make sure hydraulic hoses are installed without straining hoses. Distance from pump box to Liftgate is limited by lengths of hydraulic hoses and wiring harness supplied with Liftgate.

Position pump box frame (or optional battery box) on the ground where it will be welded to vehicle body in the next step. Make sure pump box (and battery box if supplied) are securely bolted to the frame. Typical installations are shown in **FIGS. 38-1, 38-2, 38-3, 39-1, 39-2, and 39-3.**

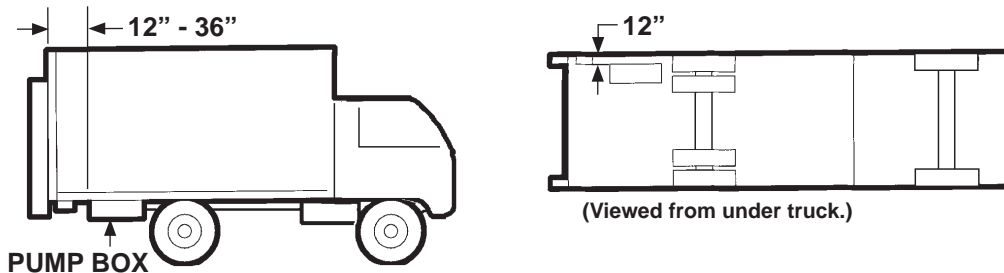

**TYPICAL 3 FT. INSTALLATION
FIG. 38-1**

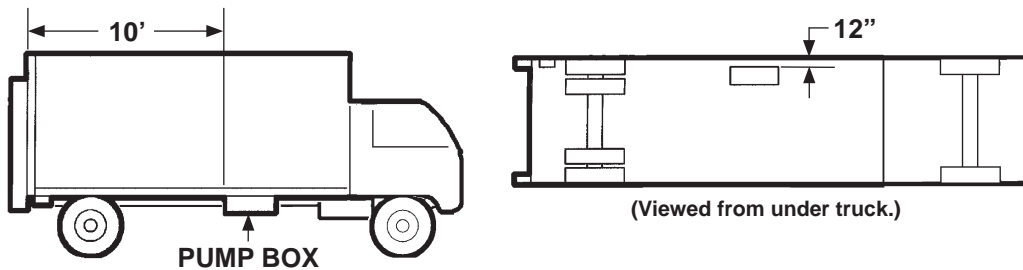

**TYPICAL 10 FT. INSTALLATION
FIG. 38-2**

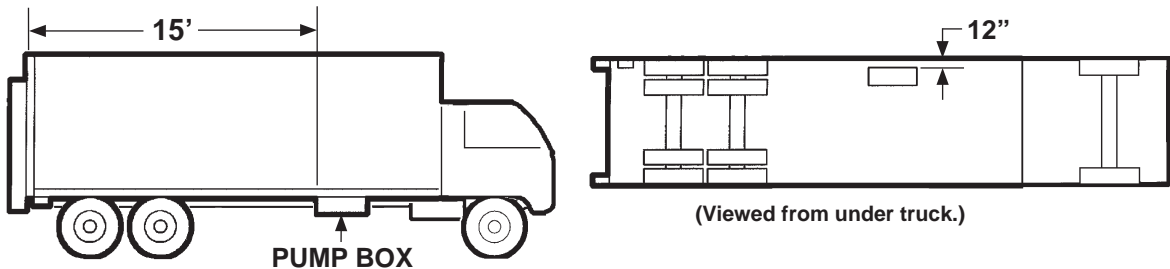

**TYPICAL 15 FT. INSTALLATION
FIG. 38-3**

STEP 6 - POSITION PUMP BOX FRAME - Continued

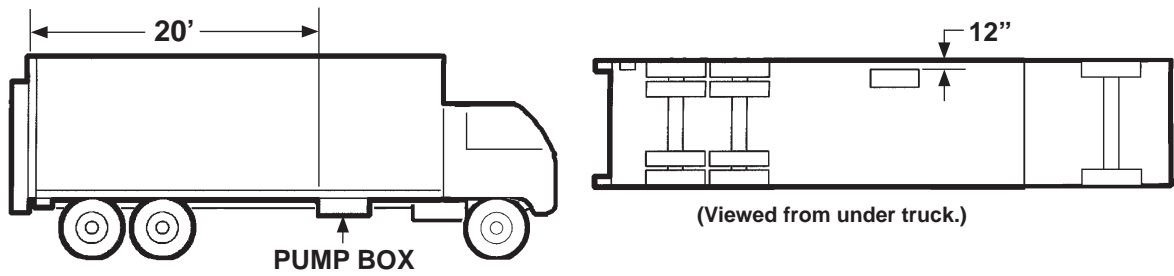

TYPICAL 20 FT. INSTALLATION
FIG. 39-1

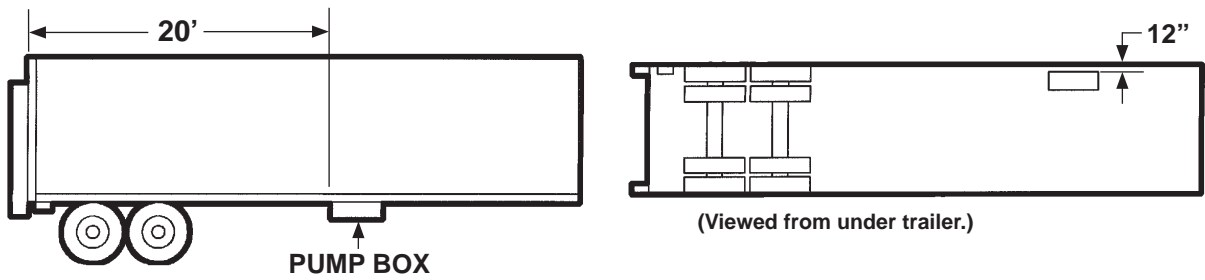

TYPICAL 20 FT. INSTALLATION
FIG. 39-2

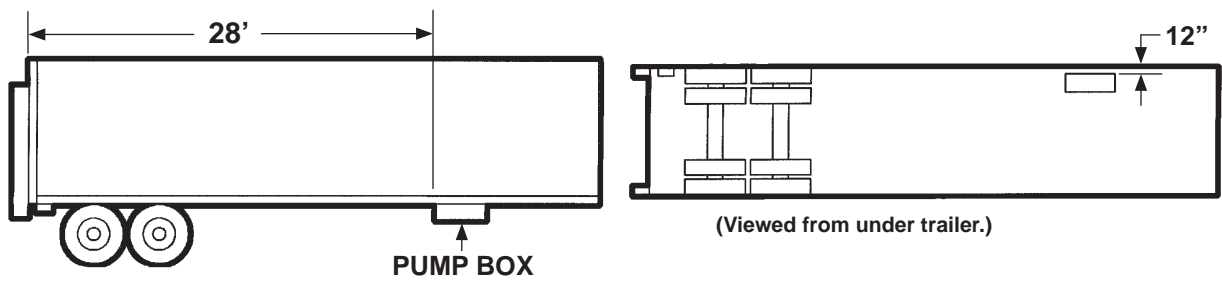

TYPICAL 28 FT. INSTALLATION
FIG. 39-3

STEP 7 - ATTACH PUMP & BATTERY BOX FRAME TO VEHICLE

NOTE: There are 2 methods to mount pump and battery box frame to vehicle frame.

- Bolt pump and battery box frame to hanger brackets welded to vehicle frame.
- Weld pump and battery box frame to vehicle frame.

1. Use floor jack or equivalent lifting device to place pump and battery box frame in position on vehicle body cross members as shown in **FIG. 40-1**.

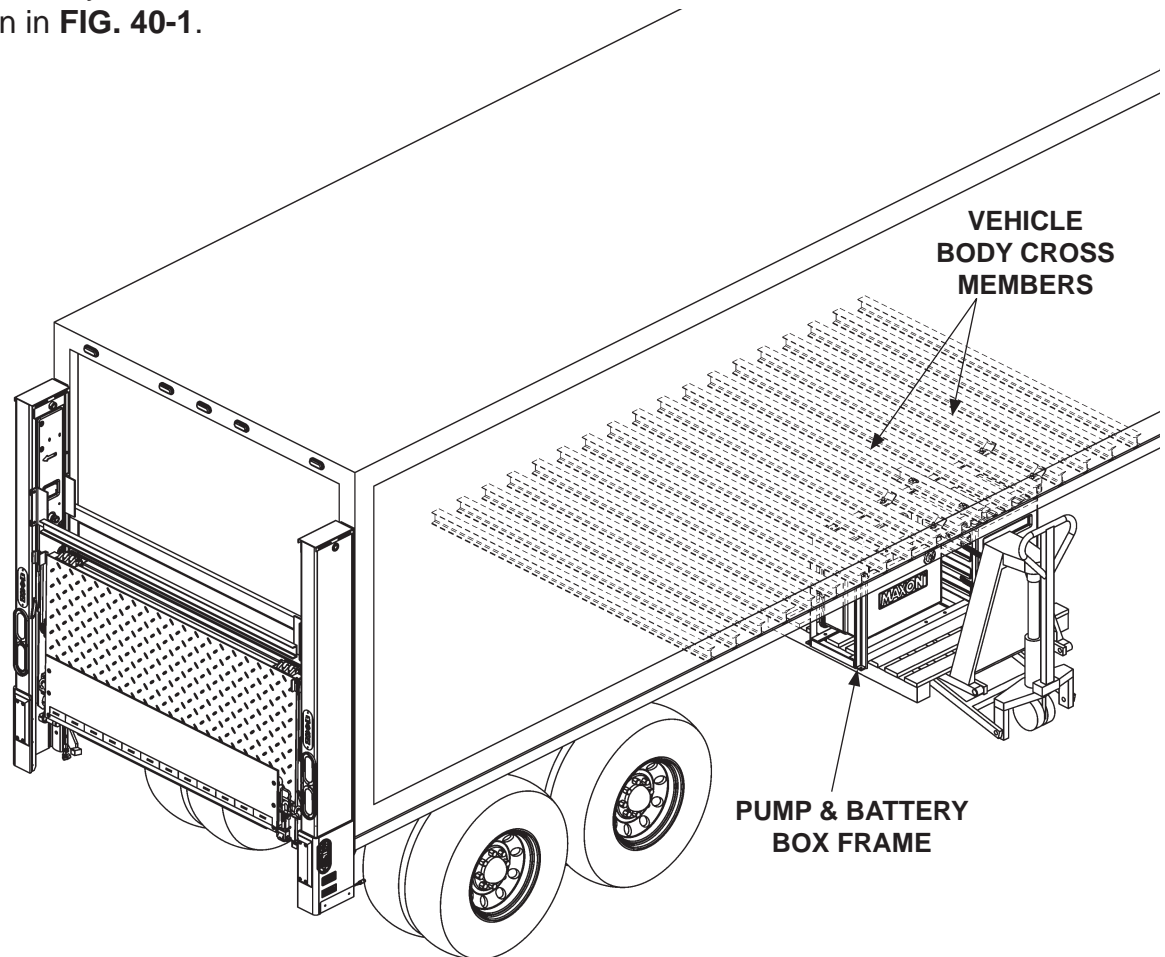

TRAILER WITH PUMP & BATTERY BOX FRAME
FIG. 40-1

NOTE: If pump and battery box frame is to be welded directly to cross members on vehicle body, skip **instructions 2 through 4**. Continue with **instruction 5**.

STEP 7 - ATTACH PUMP & BATTERY BOX FRAME TO VEHICLE - Continued

NOTE: Do instructions 2 through 4 if hanger brackets are being used to mount pump and battery box frame on vehicle.

2. Select holes on top of battery box frame to align mounting brackets flush to cross members. Refer to **FIGS. 41-1 & 41-1A** for trailers and **FIG. 41-2** for trucks. Bolt mounting brackets to battery box frame as shown in **FIG. 41-1B**. Torque each bolt and lock nut to **85-128 lb-ft.**

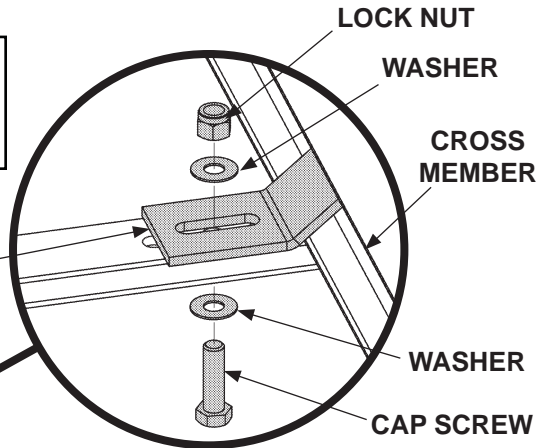

**BOLTING BRACKETS
(8 PLACES)
FIG. 41-1B**

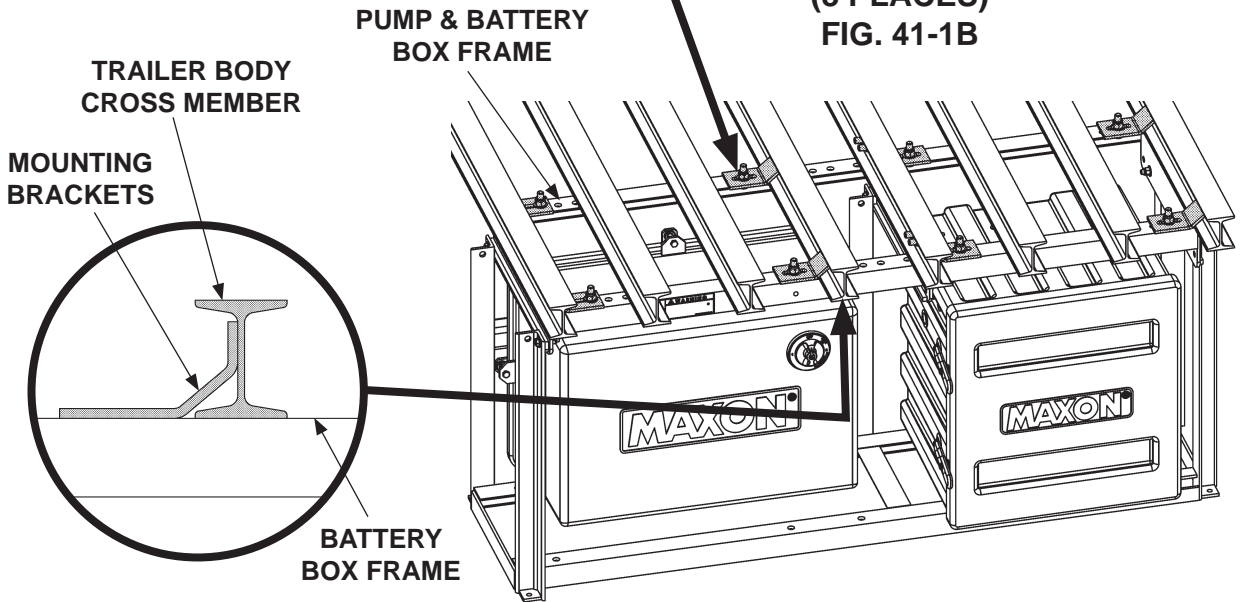

**FLUSH BRACKETS
FOR TRAILERS
(8 PLACES)
FIG. 41-1A**

**ALIGNING PUMP & BATTERY
BOX FRAME
FIG. 41-1**

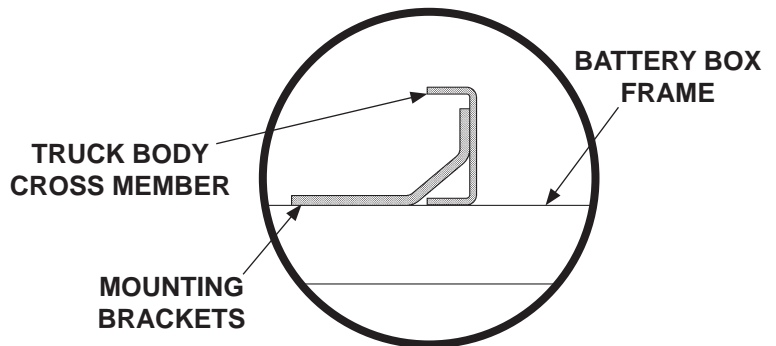

**FLUSH BRACKETS FOR TRUCKS
(8 PLACES)
FIG. 41-2**

11921 Slauson Ave. Santa Fe Springs, CA. 90670 (800) 227-4116 FAX (888) 771-7713
MAXON

STEP 7 - ATTACH PUMP & BATTERY BOX FRAME TO VEHICLE - Continued

NOTE: If welding mounting brackets to cross members, skip instruction 3.

- Using mounting brackets as a template mark and drill holes through cross members (FIG. 42-1). Bolt mounting brackets to cross members as shown in FIGS. 42-2 and 42-2A. Torque bolts and lock nuts to 85-128 lb-ft.

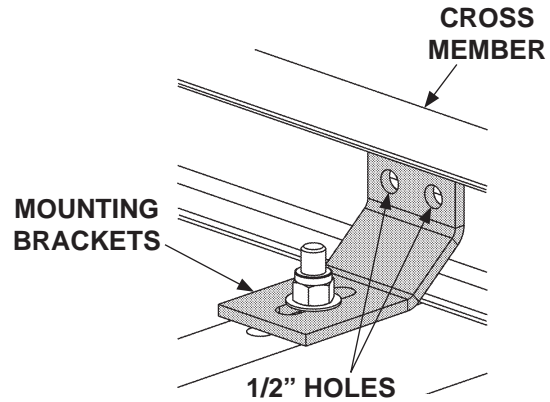

**MARK AND DRILL
FIG. 42-1**

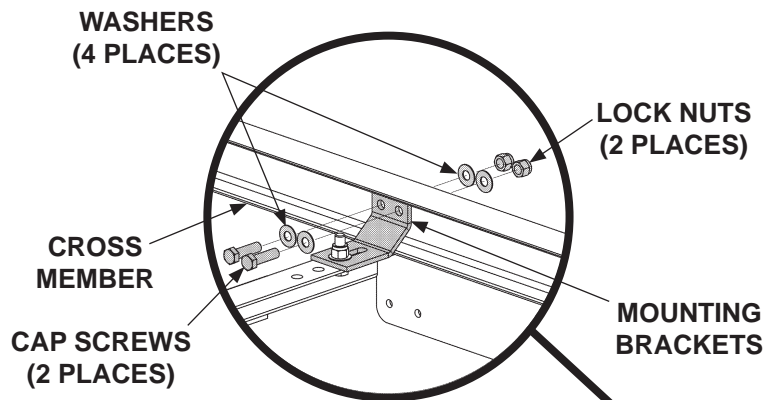

**BOLTING BRACKETS
(8 PLACES)
FIG. 42-2A**

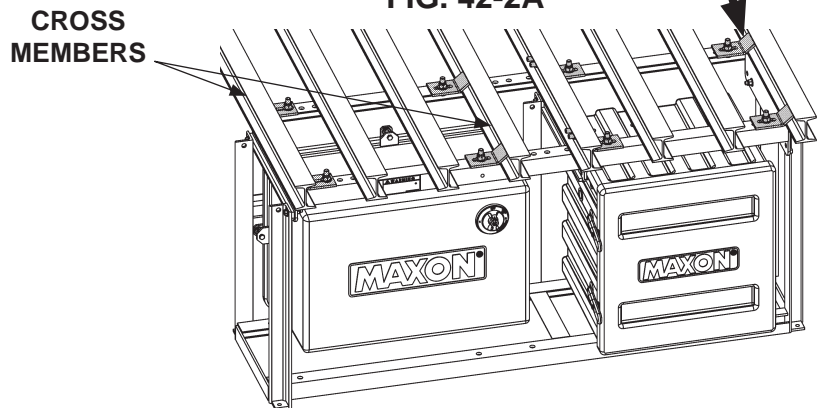

**BOLTING PUMP & BATTERY
BOX FRAME
FIG. 42-2**

STEP 7 - ATTACH PUMP & BATTERY BOX FRAME TO VEHICLE - Continued

⚠ WARNING

Recommended practices for welding on steel parts are contained in the current AWS (American Welding Society) D1.1 Structural Welding Code - Steel. Damage to Liftgate and/or vehicle, and personal injury can result from welds that are done incorrectly.

CAUTION

To prevent pump box components from being damaged by electric current from welding, connect welder grounding cable to the part being welded.

CAUTION

Cover pump box and optional battery box with flame-resistant covering before welding pump box frame to vehicle.

4. Weld each bracket to cross members as shown in **FIGS. 43-1 and 43-1A**. Weld top of bracket if accessible.

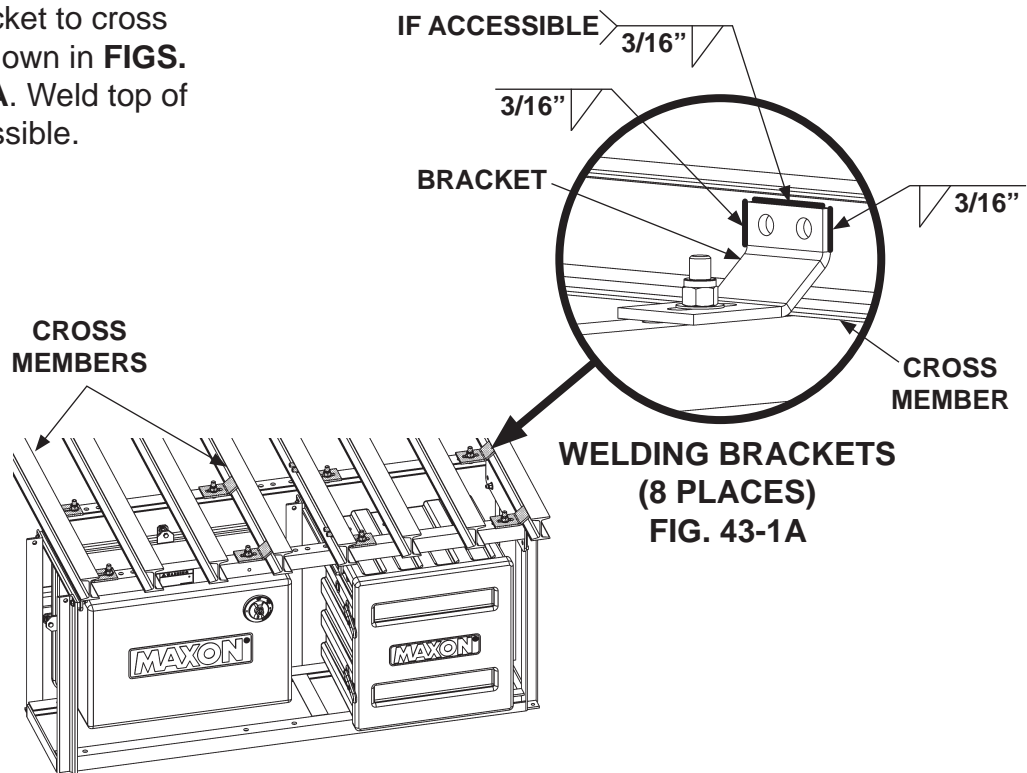

BOLTING PUMP & BATTERY BOX FRAME
FIG. 43-1

GO TO THE END OF STEP 7 & OBSERVE THE WARNING ABOUT HYDROGEN GAS BUILD-UP. THEN GO TO STEP 8.

STEP 7 - ATTACH PUMP & BATTERY BOX FRAME TO VEHICLE - Continued

NOTE: Any methods not shown in this section, for welding mounting brackets to cross members, must be approved by body or trailer manufacturer.

5. Position pump and battery box frame on vehicle frame cross members (**FIG. 44-1**). Weld pump and battery box frame to crossmembers as shown in **FIG. 44-1**.

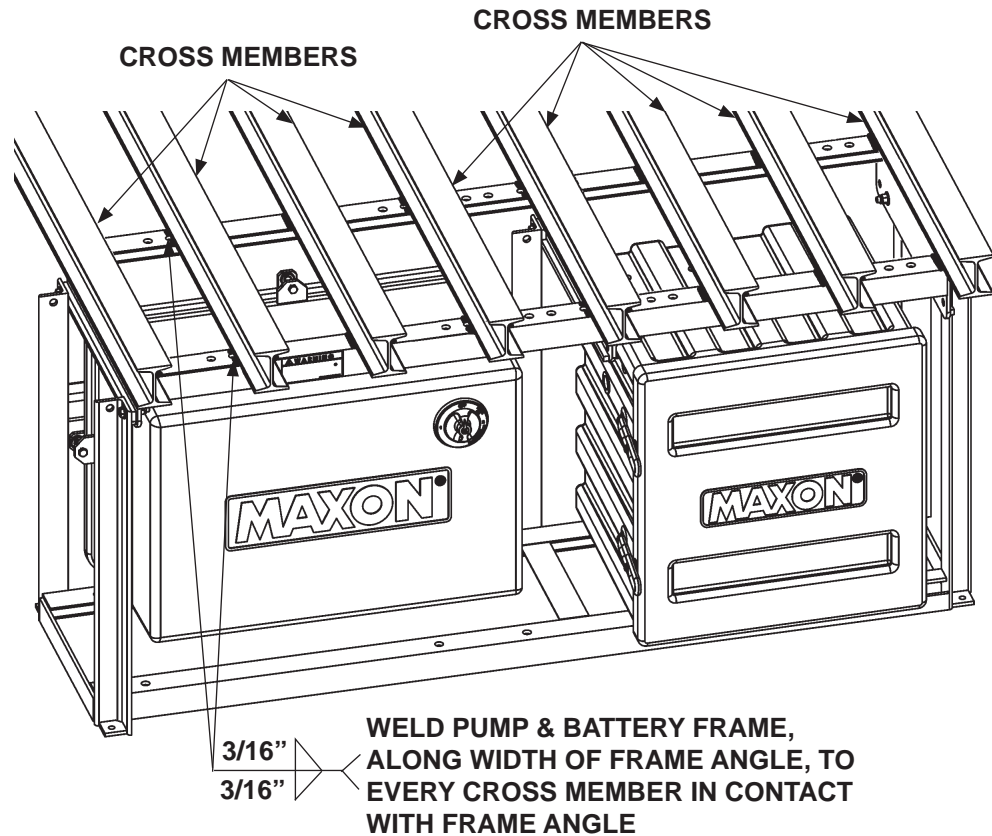

ALIGNING PUMP & BATTERY BOX FRAME TO WELD ON CROSS MEMBERS
FIG. 44-1

STEP 7 - ATTACH PUMP & BATTERY BOX FRAME TO VEHICLE - Continued

⚠ WARNING

Explosive hydrogen gas from charging batteries can accumulate in battery box if not vented from the box. To prevent hydrogen gas from accumulating, ensure the 3 ventilation holes in battery box are not plugged or covered.

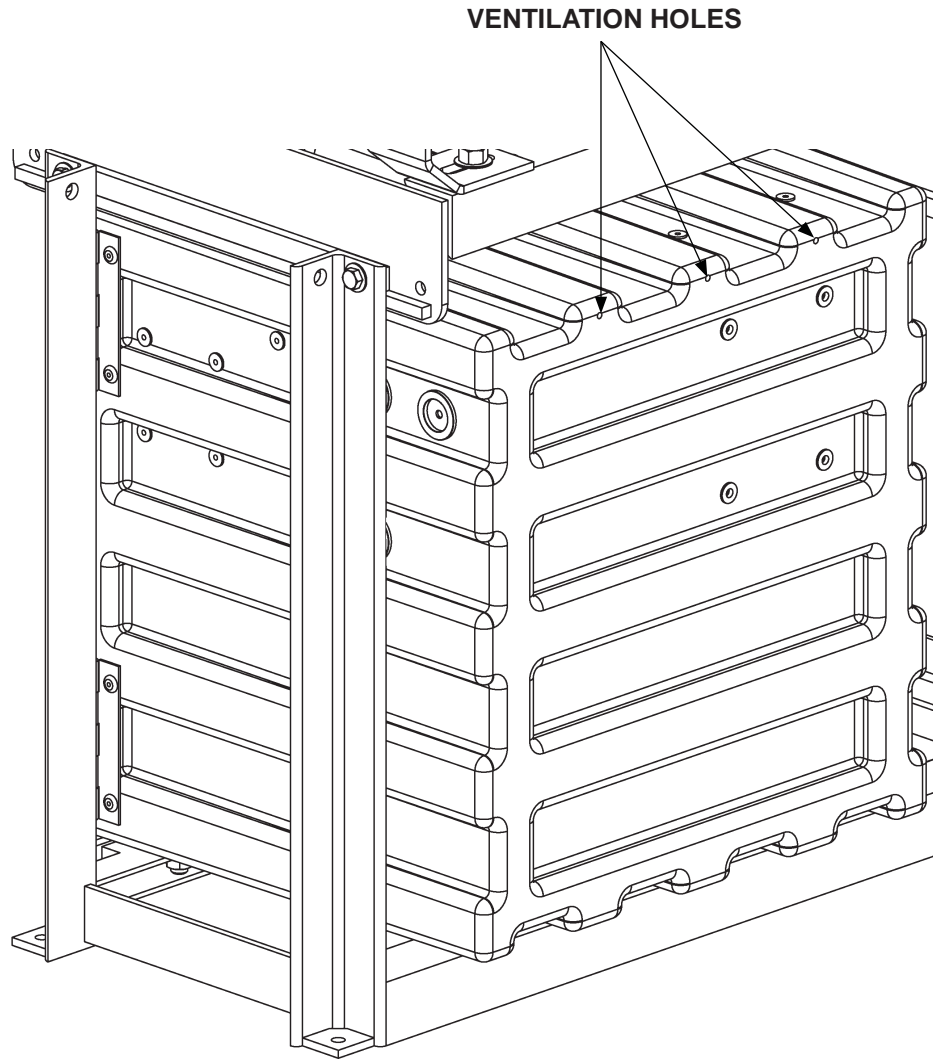

**BATTERY BOX ASSEMBLY
(REAR VIEW SHOWN)
FIG. 45-1**

STEP 8 - RUN HYDRAULIC LINES & ELECTRIC CABLES

CAUTION

Always route hydraulic hoses and electrical wiring clear of moving parts, brake lines, sharp edges and exhaust systems. Avoid making sharp bends in hoses and wiring. Make sure that bends in the electrical wiring are 1" or more away from electrical connector. Attach securely. If drilling is necessary, first check behind the drilling surface so you do not damage any fuel lines, vent lines, brake lines or wires.

NOTE: The hydraulic cylinders in the Liftgate are filled with hydraulic fluid and bled at the factory. To keep air out of the hydraulic system, follow instructions carefully for installing hydraulic system components.

NOTE: The fold and unfold hydraulic hoses are the same. To avoid confusion when running hoses through the channel, MAXON recommends taping both ends of one of the hoses for easy identification.

1. Get hydraulic hoses, hydraulic tee, channel guard (if required) and plastic ties from parts box and pump box installation kit. Run hydraulic hoses from LH and RH columns to pump box. Connect hydraulic hoses as shown in **FIG. 47-1** and **TABLES 48-1 and 48-2** for Gravity Down Liftgate or **FIG. 49-1** and **TABLES 50-1 and 50-2** for Power Down Liftgate.
2. Get molded extension cable from pump box installation kit. Run the molded extension cable from RH column to pump box as shown in **FIG. 51-1**.
3. If channel guard is required, bolt up one side of the channel (**FIGS. 47-1, 49-1 and 51-1**) to vehicle body. Leave bolts loose until all hydraulic hoses (**FIGS. 47-1 and 49-1**) and wiring harness (**FIG. 51-1**) are run through channel. After hoses and wiring harness are run, bolt up second side of channel and tighten all bolts and nuts. Use plastic ties to secure runs of hydraulic hoses and wiring harness that are outside of channel guard.

STEP 8 - RUN HYDRAULIC LINES & ELECTRIC CABLES - Continued

RUN GRAVITY DOWN HYDRAULIC LINES

NOTE: See TABLES 48-1 & 48-2 for information on the numbered hoses in this illustration.

CAUTION
Before connecting hoses, ensure face seal o-rings are in place.

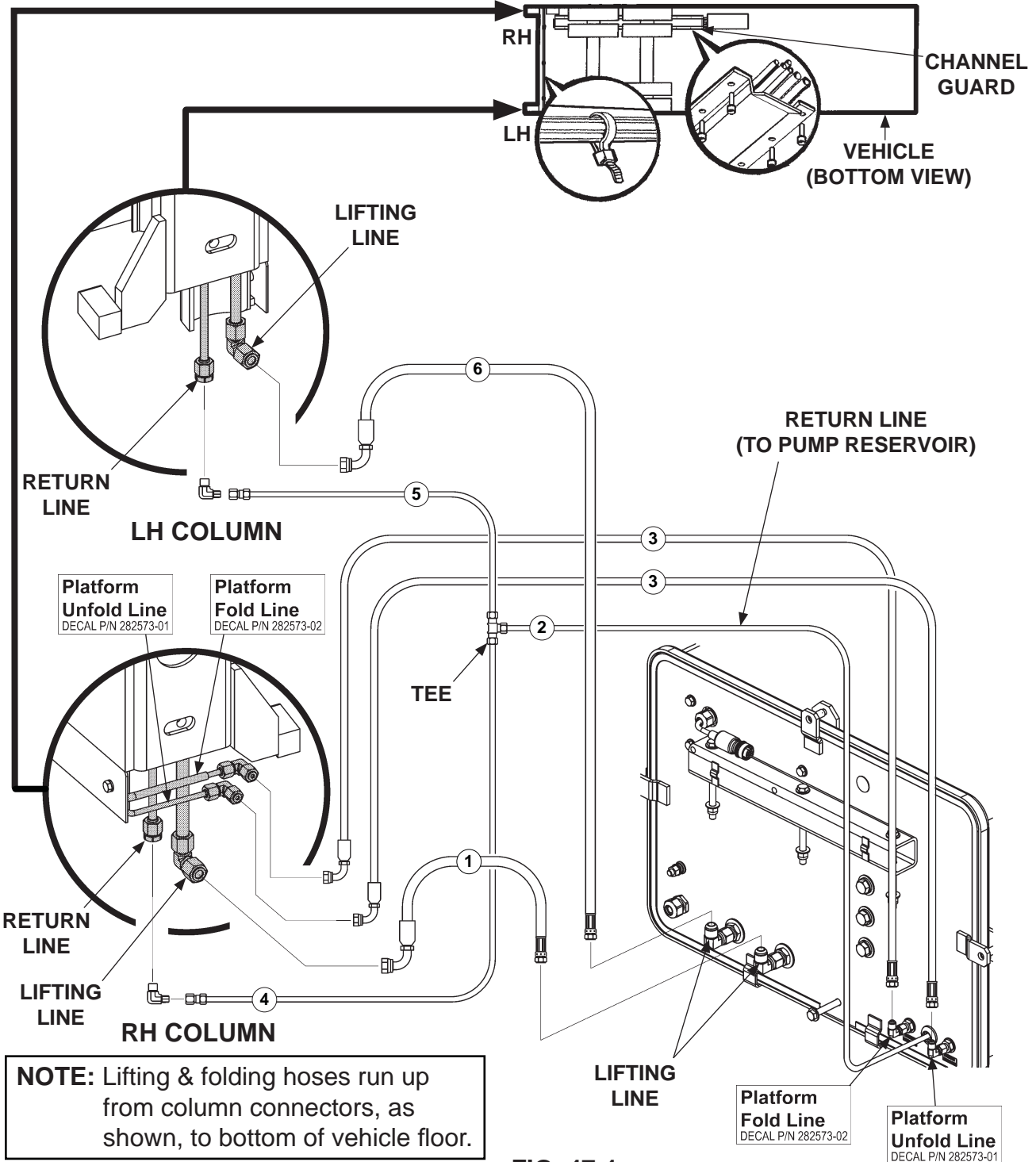

NOTE: Lifting & folding hoses run up from column connectors, as shown, to bottom of vehicle floor.

FIG. 47-1

STEP 8 - RUN HYDRAULIC LINES & ELECTRIC CABLES - Continued

RUN GRAVITY DOWN HYDRAULIC LINES

NOTE: Each pump extension kit contains 2 hoses of the same length (**item 3**). One hose is for the **Platform Fold Line** and the second hose is for the **Platform Unfold Line**. One hose has a yellow band on each connector to help connect the 2 hoses to the correct fittings. For example, connect hose with yellow bands to the **Fold Line** on the RH column and the **Fold Line** on the back of the pump box.

GRAVITY DOWN PUMP BOX INSTALLATION: REQUIRED HOSES & PLASTIC TUBING			
	3 FT.	10 FT.	15 FT.
1	HP 3/8" X 64" LG.	HP 3/8" X 196" LG.	HP 3/8" X 256" LG.
2	HP 3/8" X 64" LG.	PLASTIC 3/8" OD X 192" LG.	PLASTIC 3/8" OD X 192" LG.
3	HP 1/4" X 56" LG.	HP 1/4" X 188" LG.	HP 1/4" X 248" LG.
4	PLASTIC 3/8" OD X 24" LG.		
5	PLASTIC 3/8" OD X 108" LG.		
6	HP 3/8" X 142" LG.	HP 3/8" X 274" LG.	HP 3/8" X 334" LG.

TABLE 48-1

GRAVITY DOWN PUMP BOX INSTALLATION: REQUIRED HOSES & PLASTIC TUBING		
	20 FT.	28 FT.
1	HP 3/8" X 316" LG.	HP 3/8" X 412" LG.
2	PLASTIC 3/8" OD X 192" LG.	PLASTIC 3/8" OD X 420" LG.
3	HP 1/4" X 308" LG.	HP 1/4" X 404" LG..
4	PLASTIC 3/8" OD X 24" LG.	
5	PLASTIC 3/8" OD X 108" LG.	
6	HP 3/8" X 394" LG.	HP 3/8" X 490" LG.

TABLE 48-2

STEP 8 - RUN HYDRAULIC LINES & ELECTRIC CABLES - Continued

RUN POWER DOWN HYDRAULIC LINES

NOTE: See TABLES 50-1 & 50-2 for information on the numbered hoses in this illustration.

CAUTION
Before connecting hoses, ensure face seal o-rings are in place.

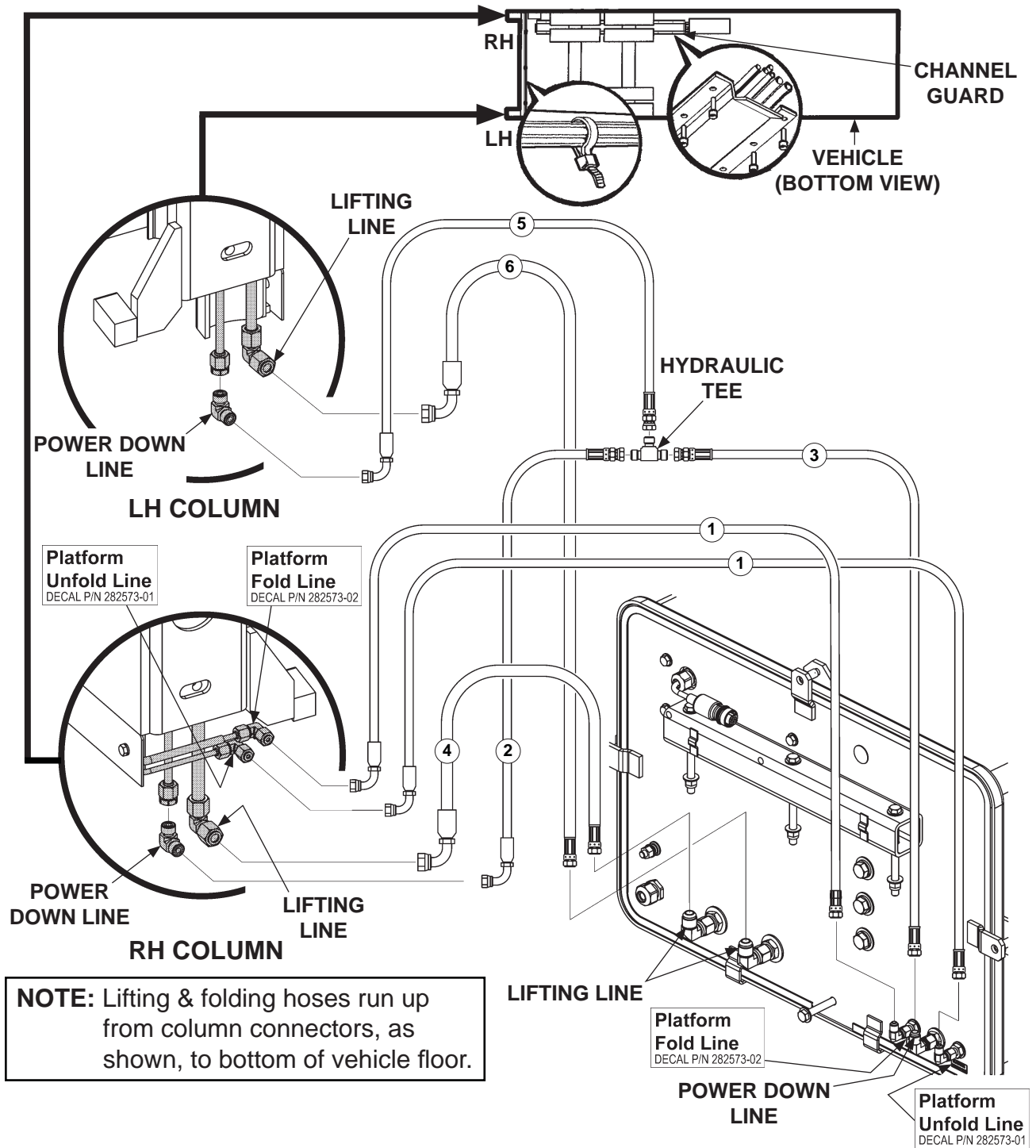

FIG. 49-1

STEP 8 - RUN HYDRAULIC LINES & ELECTRIC CABLES

- Continued

RUN HYDRAULIC LINES

NOTE: Each pump extension kit contains 2 hoses of the same length (**item 1**). One hose is for the **Platform Fold Line** and the second hose is for the **Platform Unfold Line**. One hose has a yellow band on each connector to help connect the 2 hoses to the correct fittings. For example, connect hose with yellow bands to the **Fold Line** on the RH column and the **Fold Line** on the back of the pump box.

POWER DOWN PUMP BOX INSTALLATION: REQUIRED HOSES			
	3 FT.	10 FT.	15 FT.
1	HP 1/4" X 56" LG.	HP 1/4" X 188" LG.	HP 1/4" X 248" LG.
2	HP 1/4" X 24" LG.		
3	HP 1/4" X 34" LG.	HP 1/4" X 166" LG.	HP 1/4" X 226" LG.
4	HP 3/8" X 64" LG.	HP 3/8" X 196" LG.	HP 3/8" X 256" LG.
5	HP 1/4" X 100" LG.		
6	HP 3/8" X 142" LG.	HP 3/8" X 274" LG.	HP 3/8" X 334" LG.

TABLE 50-1

POWER DOWN PUMP BOX INSTALLATION: REQUIRED HOSES		
	20 FT.	28 FT.
1	HP 1/4" X 308" LG.	HP 1/4" X 382" LG.
2	HP 1/4" X 24" LG.	
3	HP 1/4" X 286" LG.	HP 1/4" X 404" LG.
4	HP 3/8" X 316" LG.	HP 3/8" X 412" LG.
5	HP 1/4" X 100" LG.	
6	HP 3/8" X 394" LG.	HP 3/8" X 490" LG.

TABLE 50-2

STEP 8 - RUN HYDRAULIC LINES & ELECTRIC CABLES - Continued RUN ELECTRIC CABLES

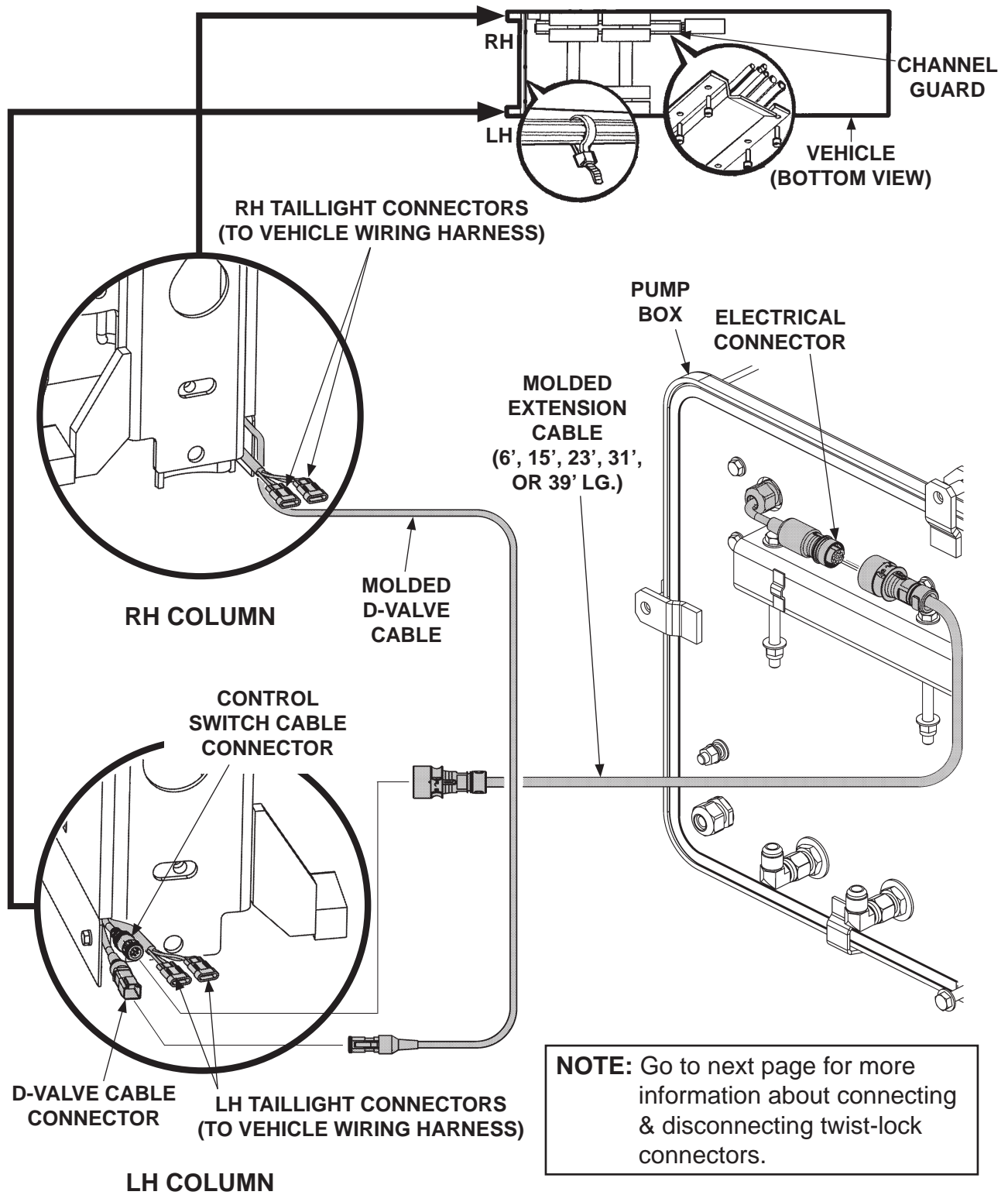

FIG. 51-1

STEP 8 - RUN HYDRAULIC LINES & ELECTRIC CABLES - Continued

WIRING HARNESS TWIST-LOCK CONNECTORS

CAUTION

Before connecting, ensure connectors are clean inside. Ensure there is a thin coating of dielectric grease on face of receptacle, and there is no dielectric grease on connector contacts.

Refer to illustrations below for disconnecting, checking for dielectric grease, and reconnecting twist-lock style connectors.

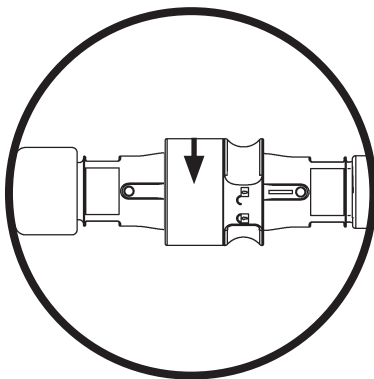

TWIST COUPLING RING TO UNLOCK
FIG. 52-1

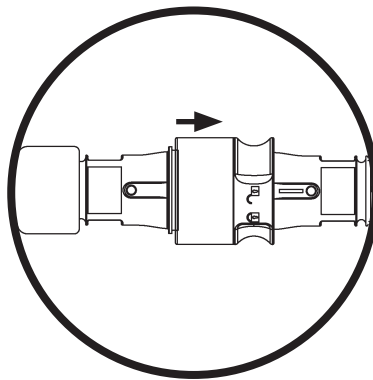

PULL COUPLING RING TO DISENGAGE
FIG. 52-2

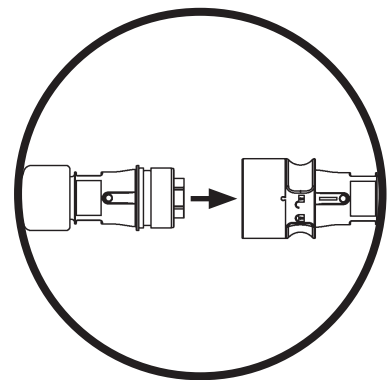

PULL CONNECTORS TO DISCONNECT
FIG. 52-3

ENSURE THERE IS A THIN COATING OF DIELECTRIC GREASE ON THIS SHADED AREA

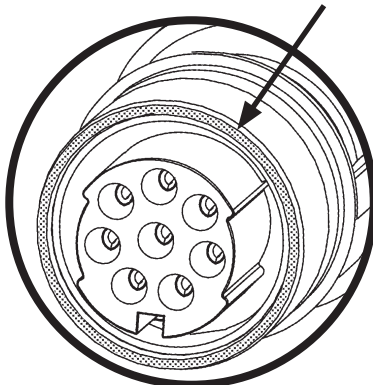

DIELECTRIC GREASE ON RECEPTACLE
FIG. 52-4

ALIGN MARKS

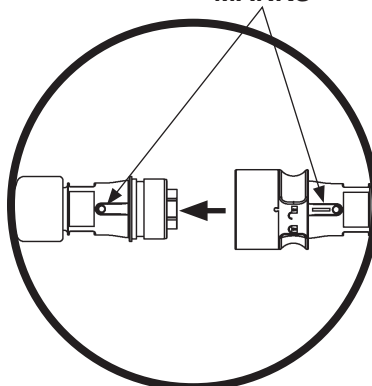

ALIGN & CONNECT
FIG. 52-5

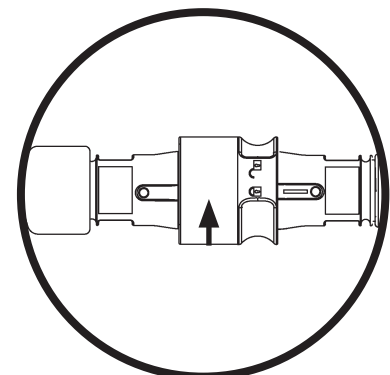

TWIST TO LOCK
FIG. 52-6

STEP 9 - CONNECT GROUND CABLE

GROUNDING TO TRUCK FRAME

NOTE: Make sure the Liftgate power unit, all batteries on the vehicle for power unit, and taillights on Liftgate are connected correctly to a common ground.

1. Bolt ground cable to the ground stud on pump box (**FIG. 53-1**).

NOTE: If there is an existing grounding point on truck frame, use it to connect ground cable and skip the step for drilling a hole.

2. Extend the ground cable to reach vehicle frame (**FIG. 53-1B**) without putting tension on cable (after connection). Connect to an existing grounding point if available.
3. If necessary, drill a 11/32" (0.343") hole in vehicle frame for bolting the ground cable terminal lug (**FIG. 53-1B**).

NOTE: Clean the ground cable connection point on the frame down to bare metal.

NOTE: MAXON recommends using dielectric grease on all electrical connections.

4. Bolt the ground cable terminal lug to vehicle frame as shown in **FIG. 53-1B**.

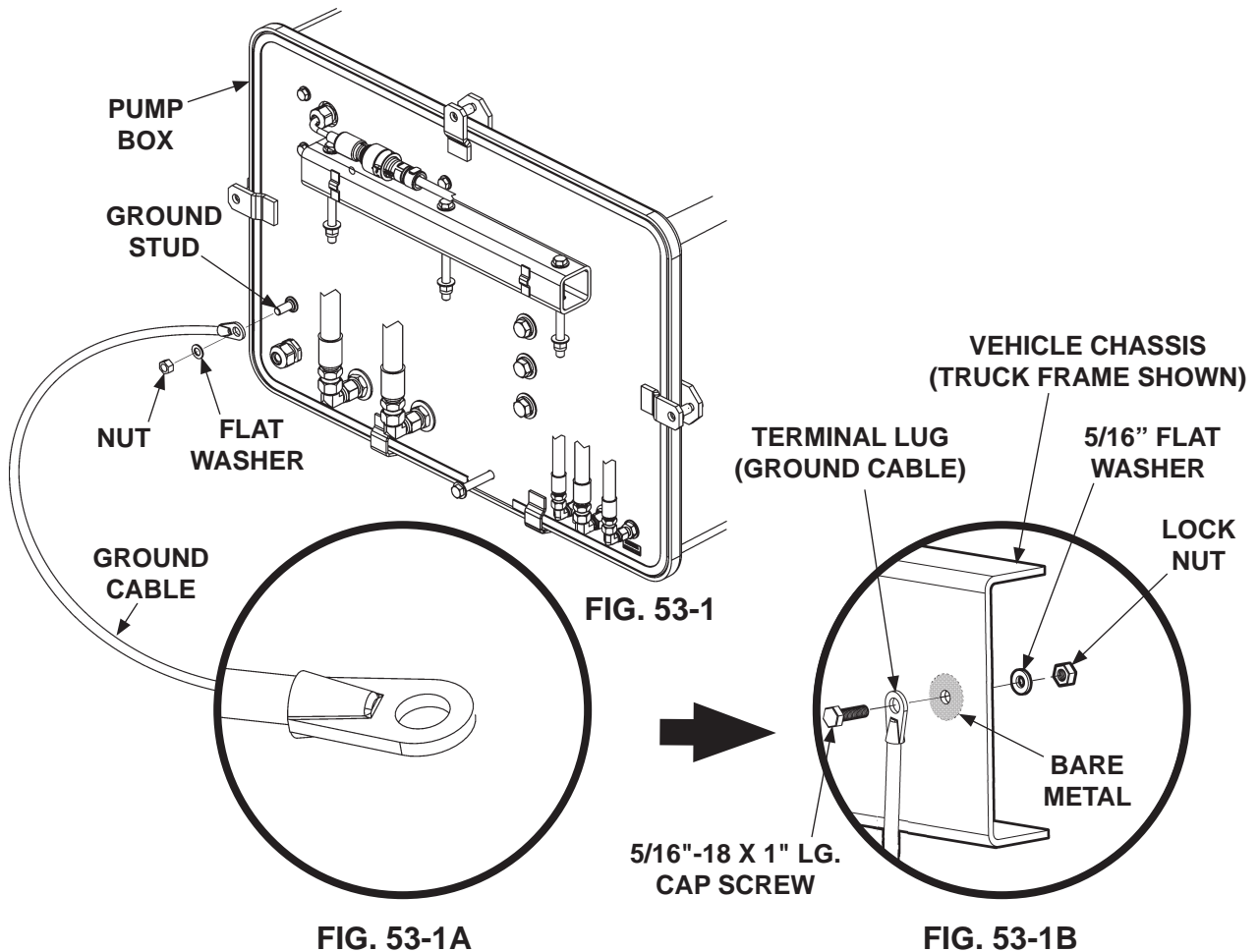

STEP 9 - CONNECT GROUND CABLE - Continued

GROUNDING TO BATTERY BOX (IF EQUIPPED)

NOTE: Make sure the Liftgate power unit, battery box and batteries, taillights on Liftgate, and vehicle charging system are connected correctly to a common ground. For trailers, if possible, use 2-pole charge line to connect charging system on tractor to the Liftgate batteries.

1. Attach ground cable to ground stud outside the pump box (**FIG. 54-1**). Tighten nut.

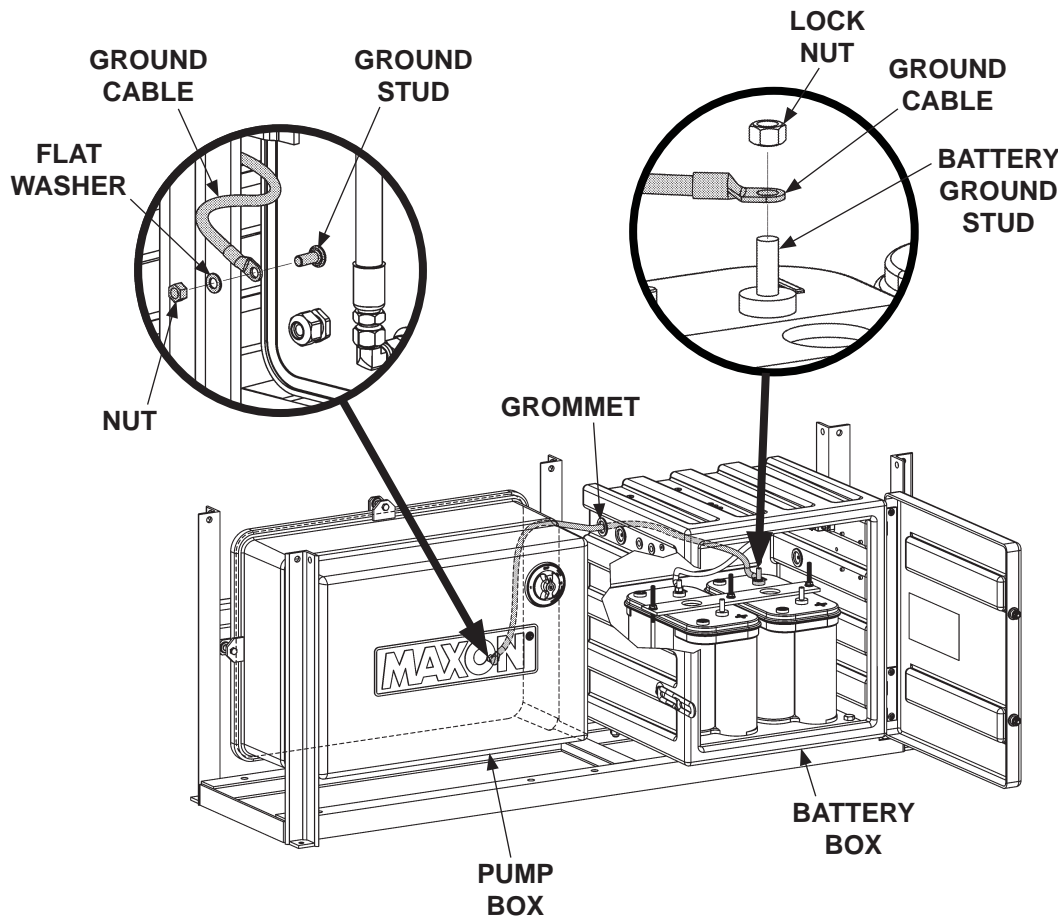

FIG. 54-1

2. Route ground cable behind pump box to the grommet on the side wall of battery box (**FIG. 54-1**). Then, pull ground cable through grommet to the battery ground stud (**FIG. 54-1**).

NOTE: Ensure battery box is connected by cable to common ground on vehicle.

3. Attach ground cable to battery ground stud (**FIG. 54-1**). Tighten lock nut.

STEP 10 - RUN CHARGE LINES

⚠ CAUTION

Never route an energized wire. Make sure battery is disconnected. Always route electrical wires clear of moving parts, brake lines, sharp edges and exhaust systems. Avoid making sharp bends in wiring. Attach securely. If drilling is necessary, first check behind the drilling surface so you do not damage any fuel lines, vent lines, brake lines or wires.

NOTE: Make sure cable is long enough to reach master disconnect switch on Liftgate pump box (or circuit breaker in optional battery box, if installed) without putting tension on the cable.

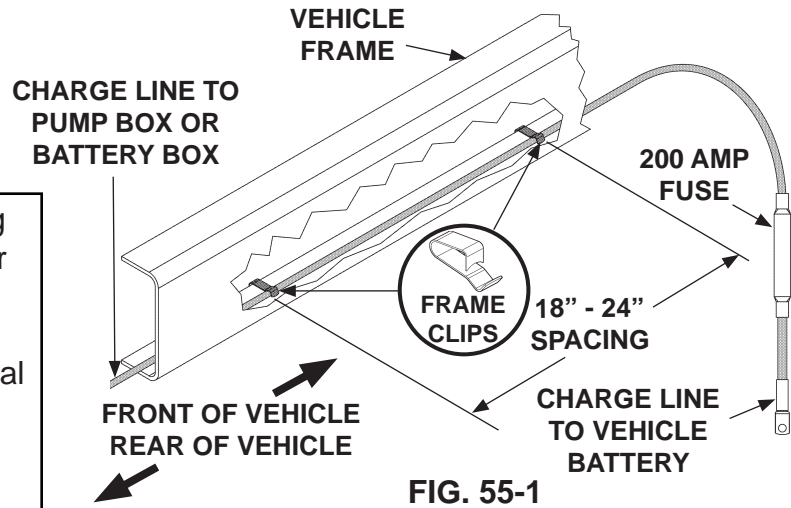

FIG. 55-1

1. Install vehicle charge line by running the line along the inside of vehicle frame (FIG. 55-1). Make sure **200 amp fuse** (FIG. 55-1) end of cable is by the vehicle battery. Run the charge line from vehicle battery to Liftgate pump box master disconnect switch (FIG. 55-2) or 150 amp circuit breaker in optional battery box (FIG. 55-3), if installed. Use frame clips (parts box item) and plastic ties (as required) from charge line kit to secure cable.

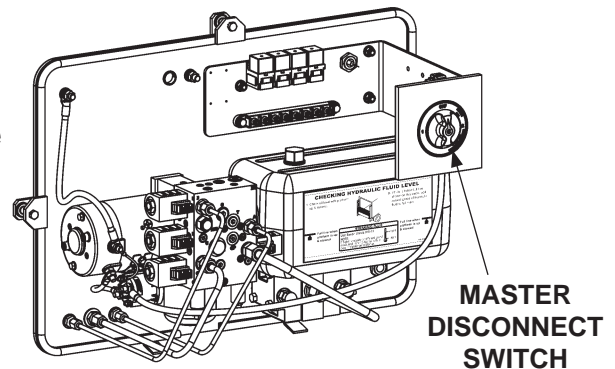

FIG. 55-2

2. If Liftgate comes with:

- Single Pole Tractor Charge Line Kit
- Single Pole Trailer Charge Line Kit
- Dual Pole Tractor Charge Line Kit
- Dual Pole Trailer Charge Line Kit

Install charge line according to **Instruction Sheet** contained in each kit.

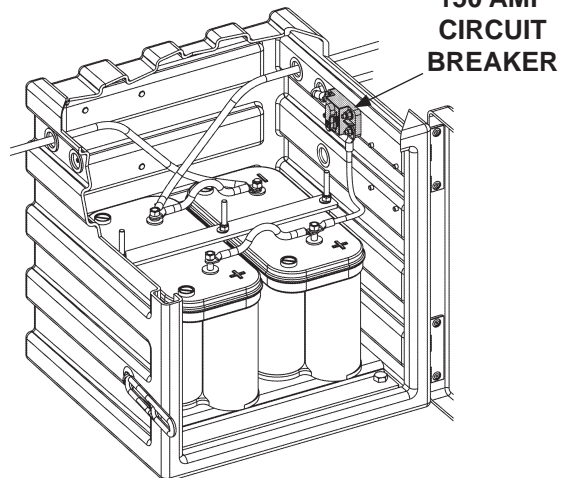
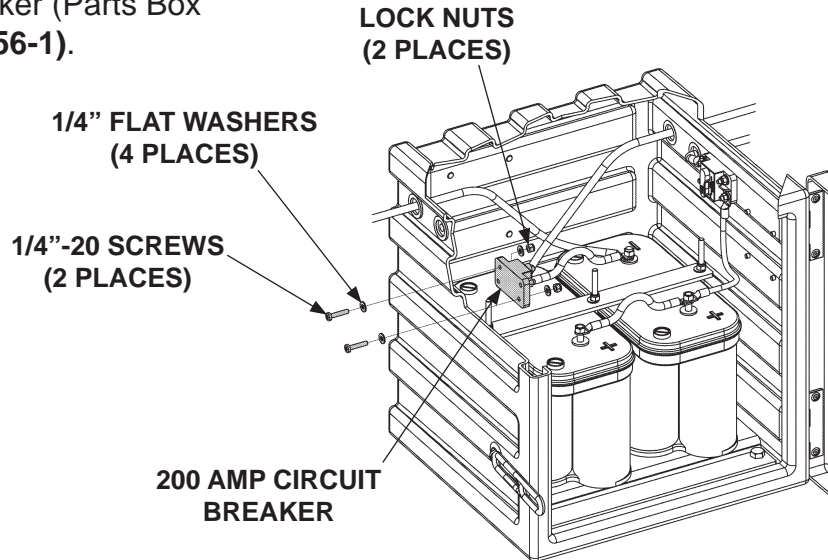

FIG. 55-3

STEP 10 - RUN CHARGE LINES - Continued

NOTE: If your optional battery box is equipped with 200 amp circuit breaker and short red cable, skip instructions **3** and **4**.

3. Bolt 200 amp circuit breaker (Parts Box item) to pump box (**FIG. 56-1**).



**BATTERY BOX
FIG. 56-1**

STEP 10 - RUN CHARGE LINES - Continued

4. Get cable (parts box) and connect to 200 amp circuit breaker as shown in **FIGS. 57-1 and 57-1A**.

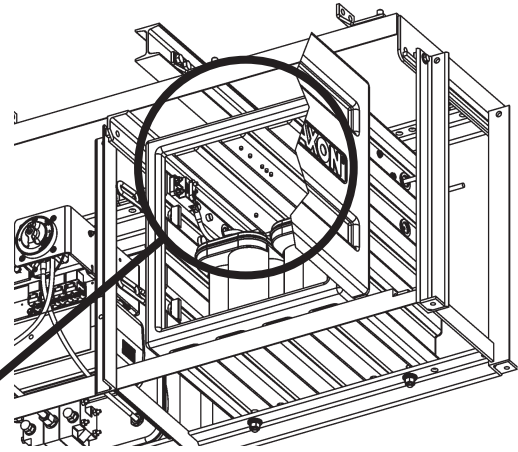

FIG. 57-1

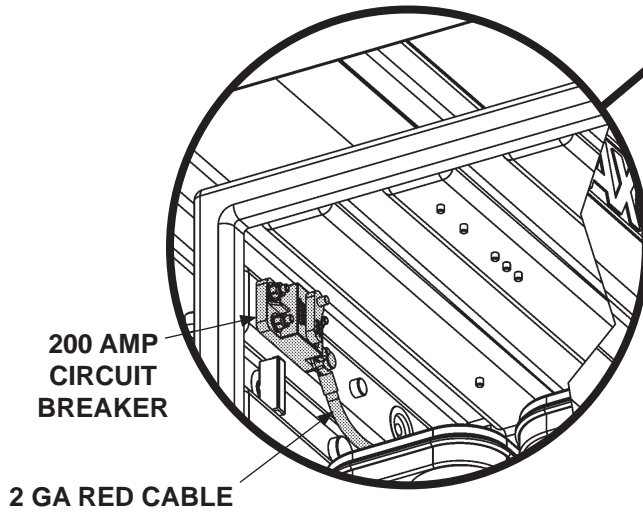
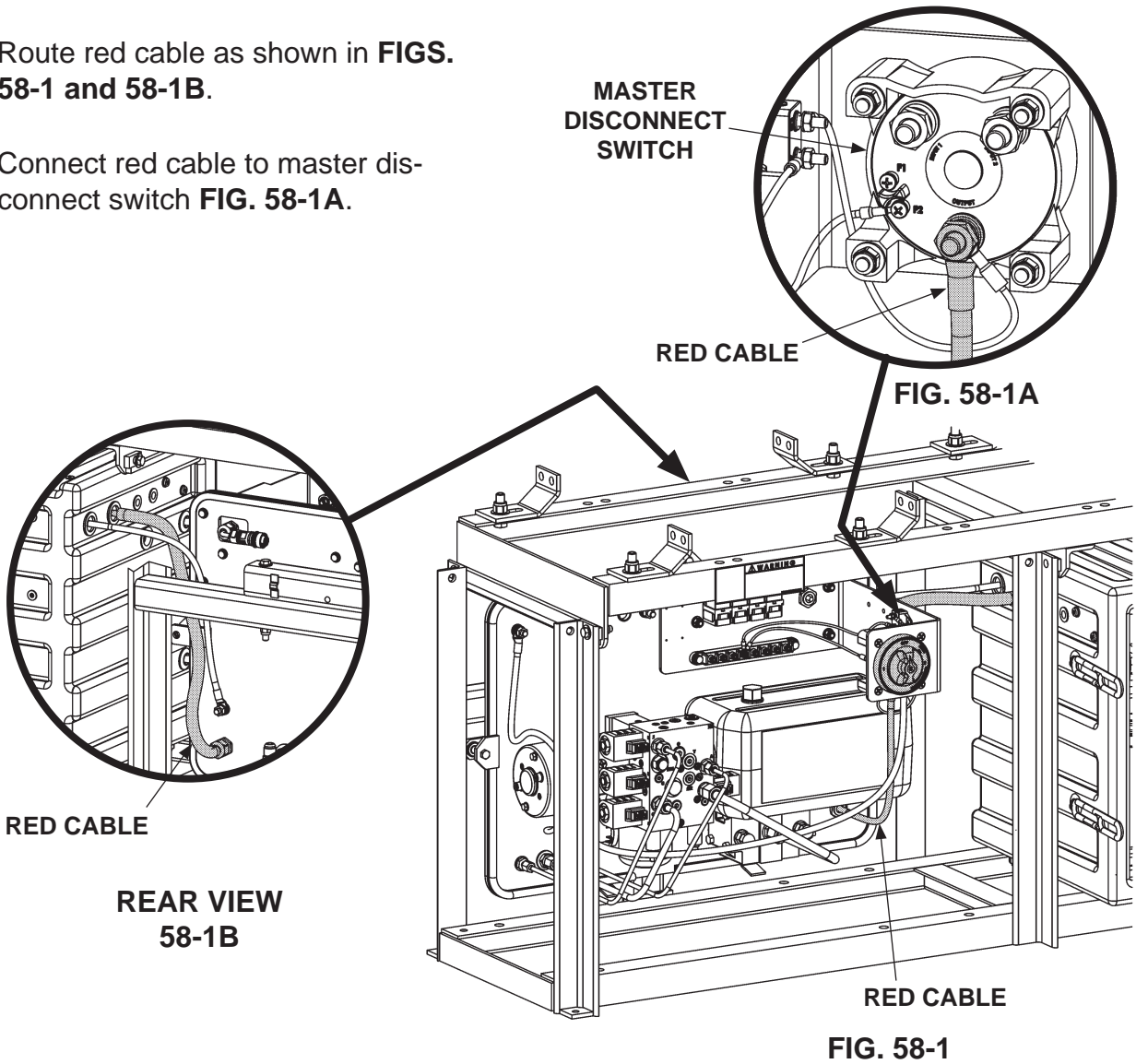

FIG. 57-1A

STEP 10 - RUN CHARGE LINES - Continued

- 5. Route red cable as shown in FIGS. 58-1 and 58-1B.
- 6. Connect red cable to master disconnect switch FIG. 58-1A.



MAXON® 11921 Slauson Ave. Santa Fe Springs, CA. 90670 (800) 227-4116 FAX (888) 771-7713

STEP 11 - CONNECT BATTERIES TO LIFTGATE

⚠ WARNING

To prevent injury and equipment damage, make sure (-) battery cable is disconnected and master disconnect switch is in the OFF position before connecting vehicle charge lines or power cables.

NOTE: For recommended 12 volt battery connections, refer to the **RECOMMENDED LIFTGATE POWER CONFIGURATION** section in this manual.

NOTE: Ensure batteries are full charged before operating Liftgate & before delivery to customer.

1. Disconnect (-) battery cable (FIG. 59-1) from battery.
2. If optional battery box is installed, connect vehicle charge line to unconnected terminal on master disconnect switch (FIGS. 59-2 and 59-2A).

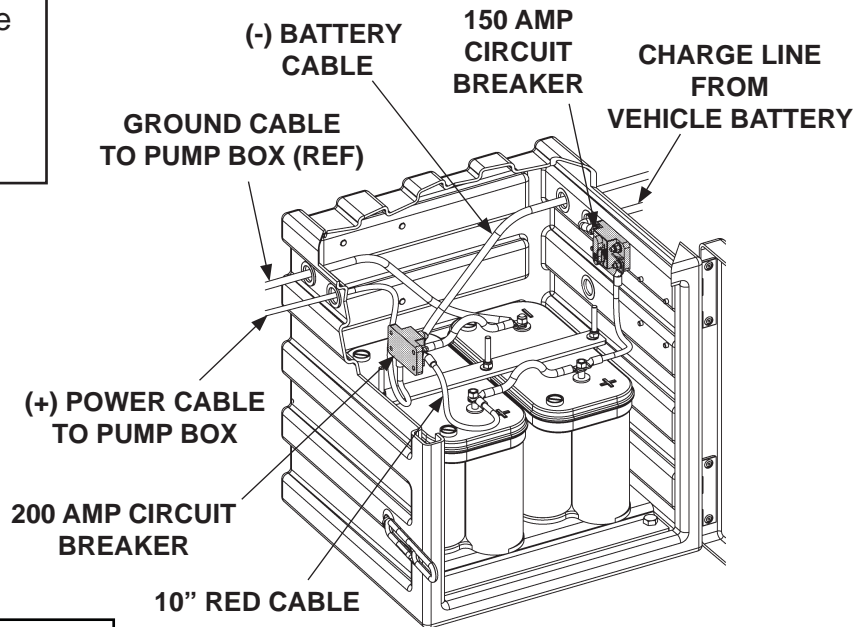

**BATTERY BOX
FIG. 59-1**

NOTE: If your optional battery box has the 200 amp circuit breaker and short red cable installed, skip instruction 3.

NOTE: After battery cables are connected, ensure pump box cover and battery box cover (if equipped) are closed.

3. If optional battery box (FIG. 59-1) is installed, connect 10" red cable (Parts Box item) between 200 amp circuit breaker and battery (+) terminal (FIG. 59-1). Next, connect (+) power cable between 200 amp circuit breaker in battery box and master switch in the pump box (FIG. 59-2). Then, connect vehicle charge line to 150 amp circuit breaker in battery box (FIG. 59-1).

**MASTER
DISCONNECT
SWITCH**

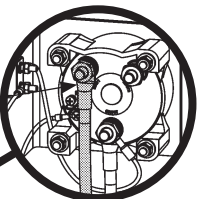
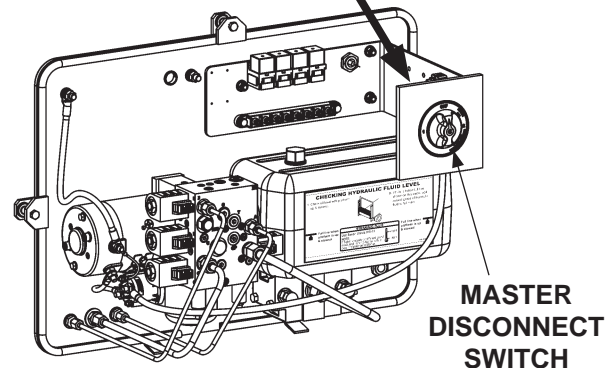

FIG. 59-2A



**PUMP BOX
FIG. 59-2**

STEP 12 - ADD HYDRAULIC FLUID TO RESERVOIR

CAUTION

Keep dirt, water and other contaminants from entering the hydraulic system. Before opening the hydraulic fluid reservoir filler cap, drain plug and hydraulic lines, clean up contaminants that can get in the openings. Also, protect the openings from accidental contamination.

1. Open pump box cover (FIG. 60-1).

2. Remove the filler cap (FIGS. 60-1 and 60-1A). Add 7 quarts of Exxon Unis HVI-13 hydraulic fluid to pump reservoir until fluid level reaches the full line.

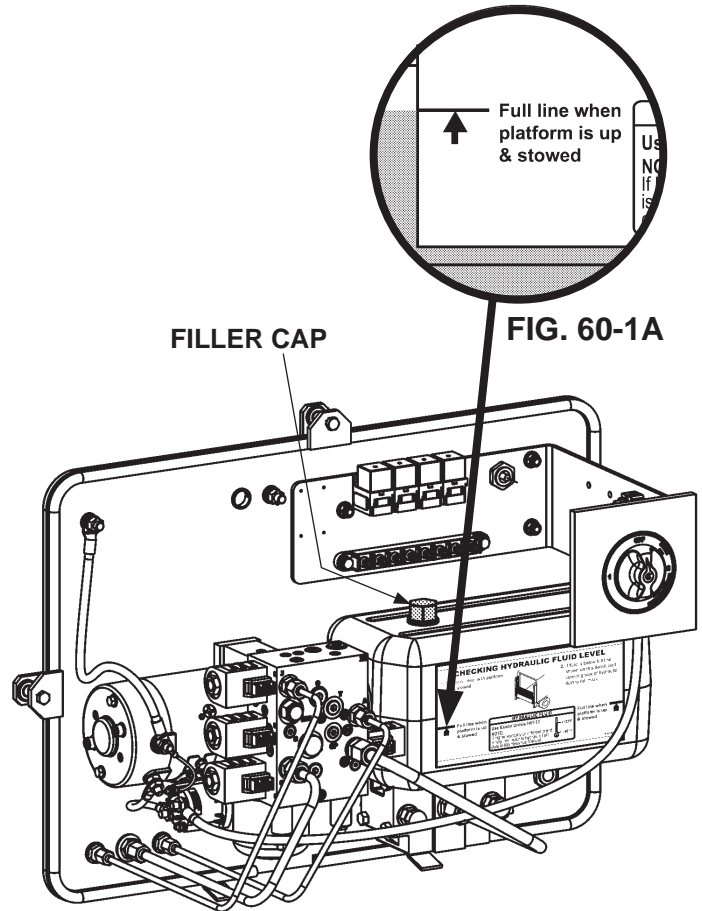

PUMP BOX SHOWN WITH SINGLE PUMP
FIG. 60-1

3. Reinstall the filler cap (FIG. 60-1).

STEP 13 - PRESSURIZE HYDRAULIC SYSTEM

⚠ WARNING

To prevent injury and equipment damage, pressurize hydraulic system before removing lower support fixtures and operating Liftgate.

NOTE: Before operating liftgate, read and understand the operating instructions in the **Operation Manual**.

1. To pressurize lifting cylinders, set control box toggle switch to **UP** for 10-15 seconds as shown in **FIG. 61-1**.

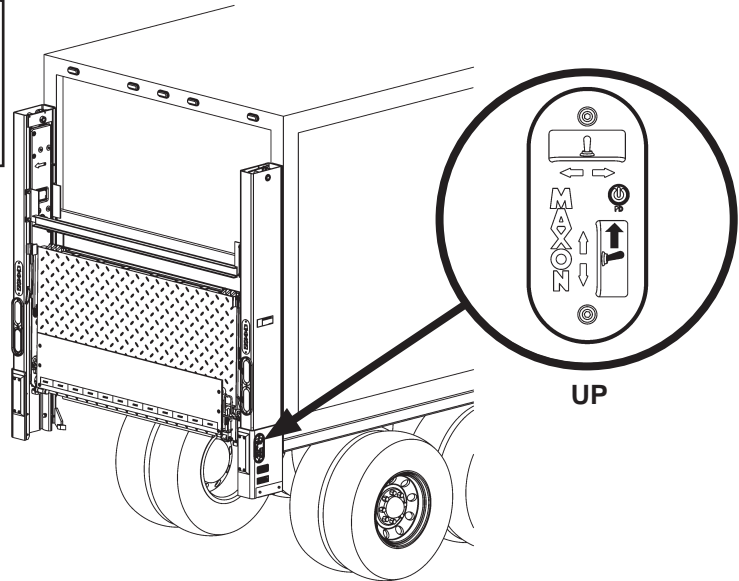

PRESSURIZING LIFTING CYLINDERS
FIG. 61-1

2. To pressurize closing cylinder, set control box toggle switches to **FOLD** for 10-15 seconds as shown in **FIG. 61-2**.

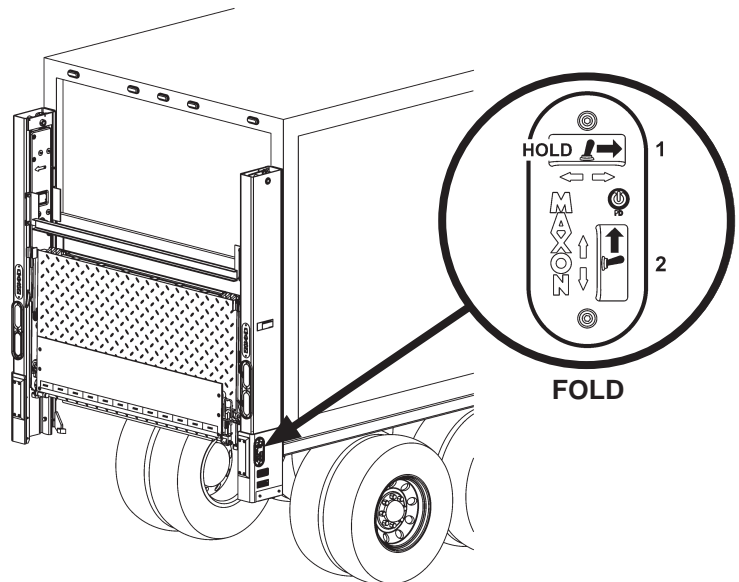

PRESSURIZING CLOSING CYLINDER
FIG. 61-2

NOTE: Liftgate is shipped with **Exxon Unavis HVI-13** hydraulic fluid in the hydraulic cylinders. This fluid is suitable for operation in temperature range of **-40° F to +120° F**. If necessary, a different brand or higher viscosity hydraulic fluid may be used. Refer to the **CHANGING HYDRAULIC FLUID** procedure in the **BMR Maintenance Manual**.

STEP 14 - OPTIMIZE HYDRAULIC FLUID LEVEL

NOTE: If equipped, select **power down on demand** for optimizing hydraulic fluid level (FIG. 62-1).

1. Lower (**DOWN**) the platform about 6" using toggle switch settings shown in FIG. 62-1.

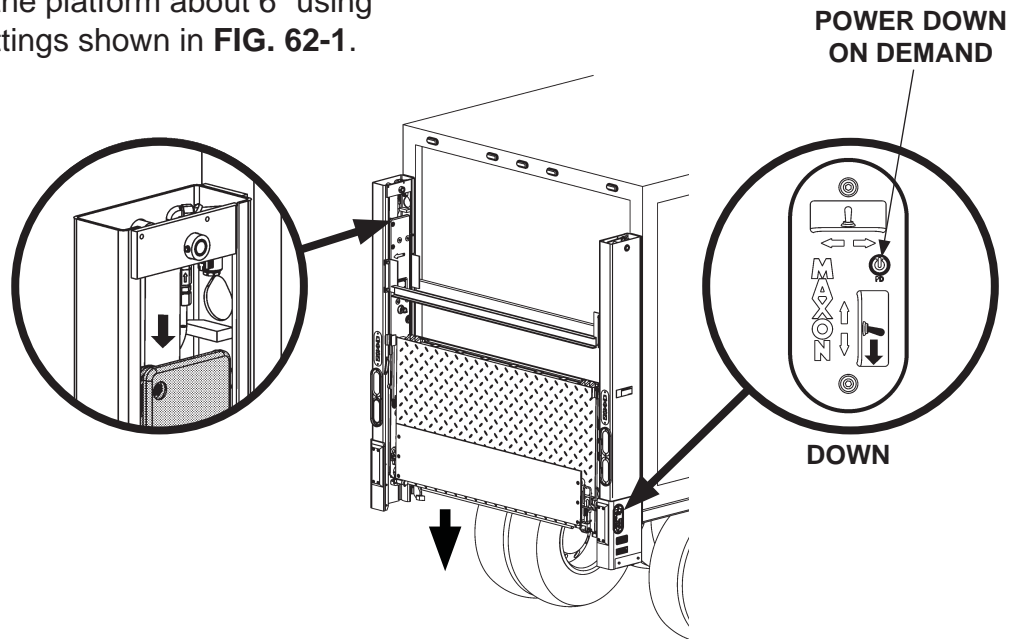

**LOWERING PLATFORM
FIG. 62-1**

2. Open (**UNFOLD**) the platform by setting toggle switches as shown in FIG. 62-2.

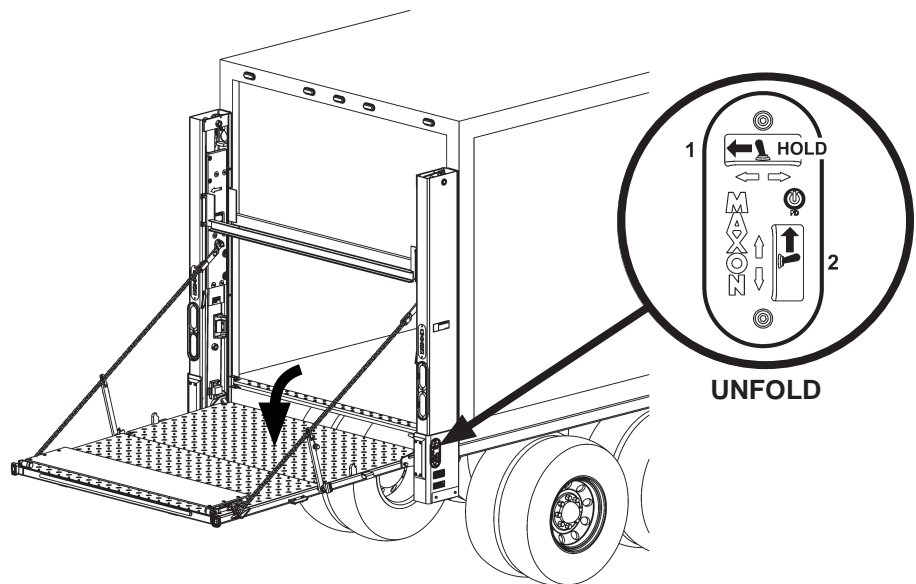

**UNFOLDING PLATFORM
FIG. 62-2**

STEP 14 - OPTIMIZE HYDRAULIC FLUID LEVEL - Continued

3. Close (**FOLD**) the platform by setting toggle switches as shown in **FIG. 63-1**. Then, open (**UNFOLD**) the platform by setting toggle switches as shown in **FIG. 63-2**.

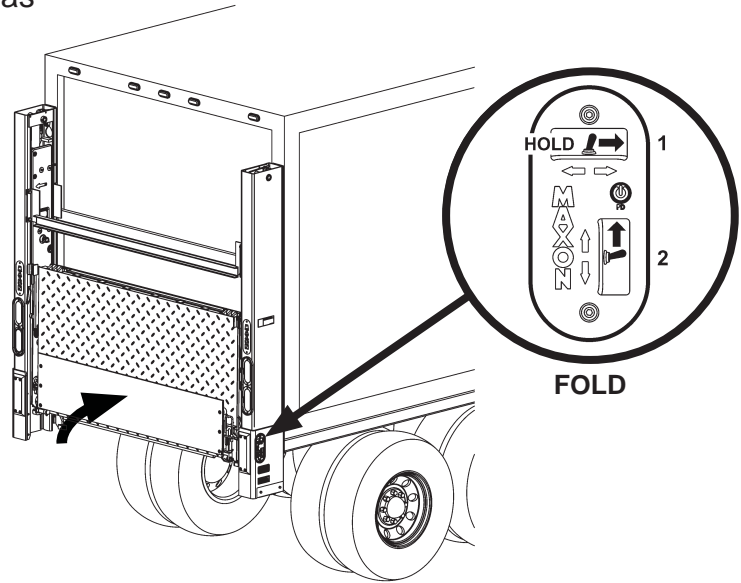

FOLDING PLATFORM
FIG. 63-1

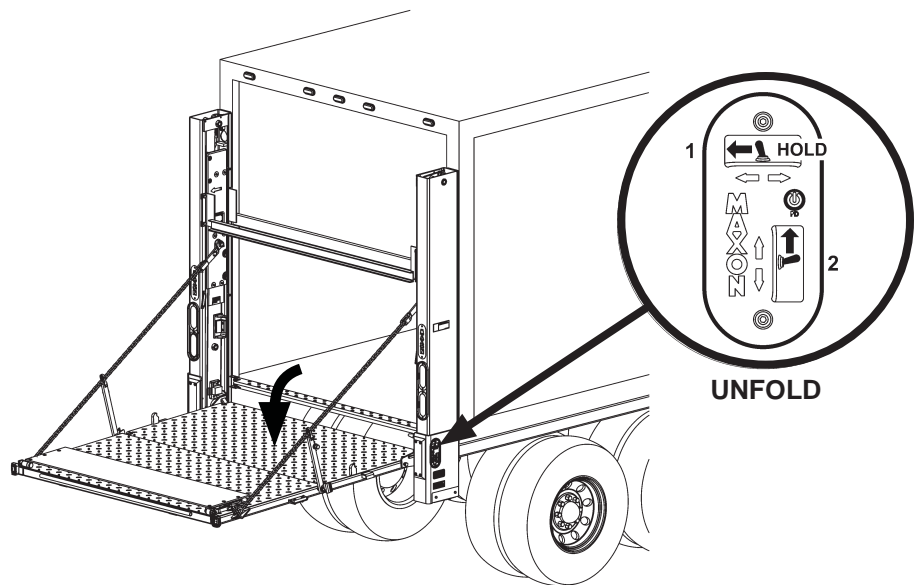

UNFOLDING PLATFORM
FIG. 63-2

STEP 14 - OPTIMIZE HYDRAULIC FLUID LEVEL - Continued

4. Lower (**DOWN**) the platform to 10" above ground level using the toggle switch settings shown in **FIG. 64-1**.

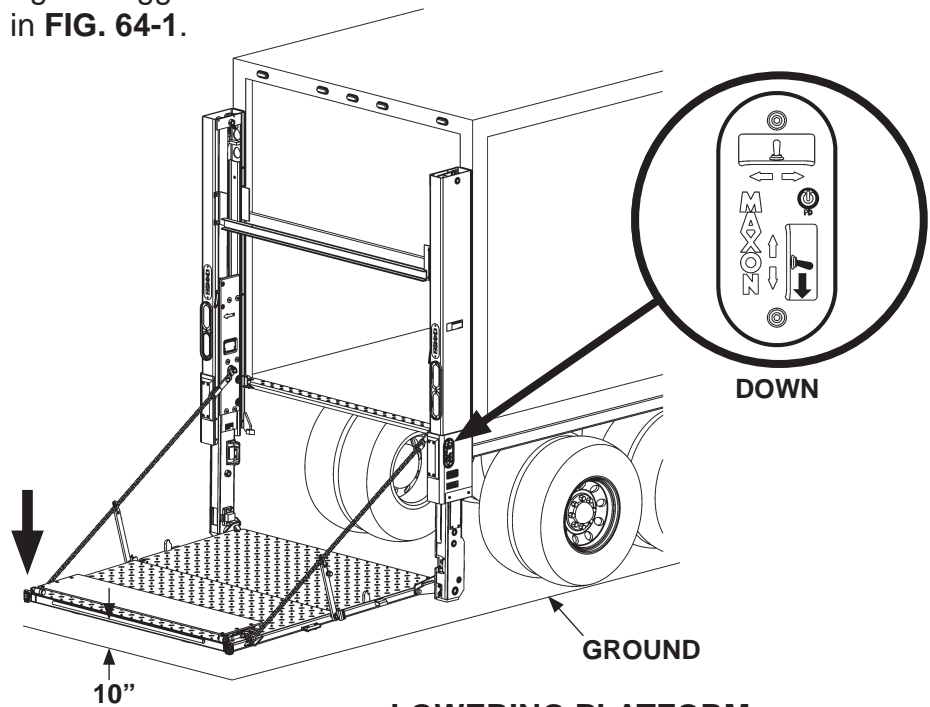

LOWERING PLATFORM
FIG. 64-1

5. Raise (**UP**) the platform to about 6" below bed height using toggle switch setting shown in **FIG. 64-2**.

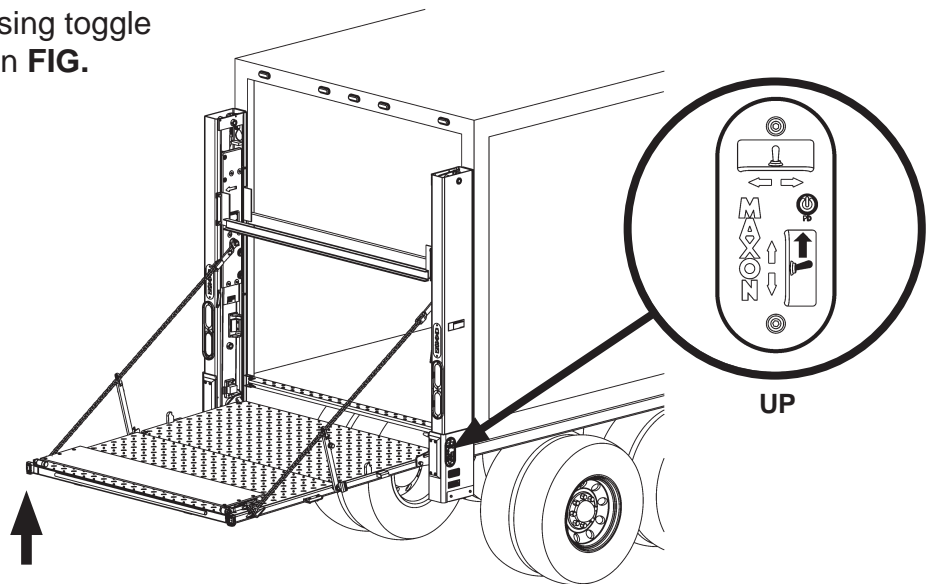

RAISING PLATFORM
FIG. 64-2

STEP 14 - OPTIMIZE HYDRAULIC FLUID LEVEL - Continued

6. Close (**FOLD**) the platform by setting toggle switches as shown in **FIG. 65-1**.

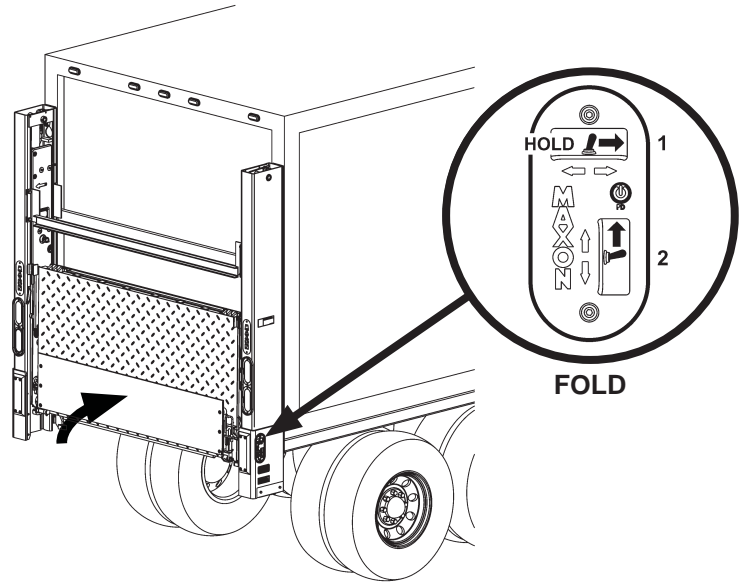

FOLDING PLATFORM
FIG. 65-1

7. Raise (**UP**) the runners to stow platform by setting toggle switches as shown in **FIG. 65-2**.

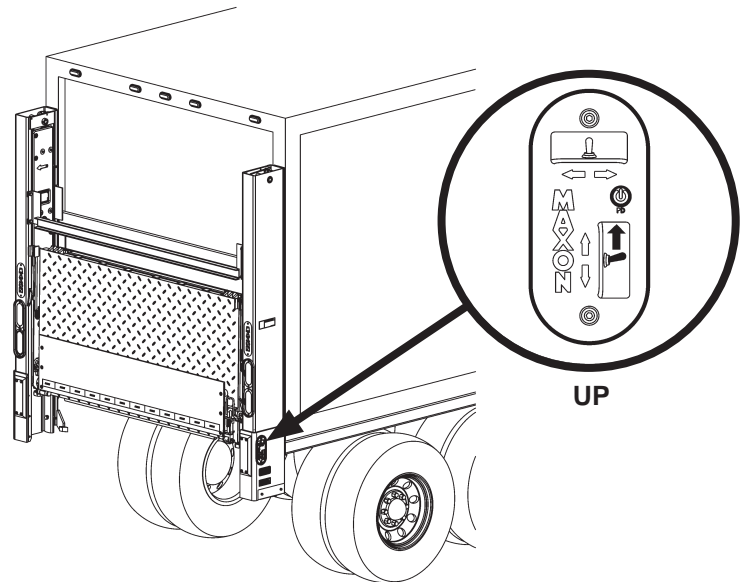

RAISING PLATFORM
FIG. 65-2

STEP 14 - OPTIMIZE HYDRAULIC FLUID LEVEL - Continued

NOTE: Information for checking hydraulic fluid level is shown on a decal on the pump reservoir.

8. Check if hydraulic fluid level is at the full line (**FIG. 66-1**). If necessary, remove filler cap (**FIG. 66-1**) and add hydraulic fluid until level rises to the full line (**FIG. 66-1**). Then, reinstall filler cap (**FIG. 66-1**).

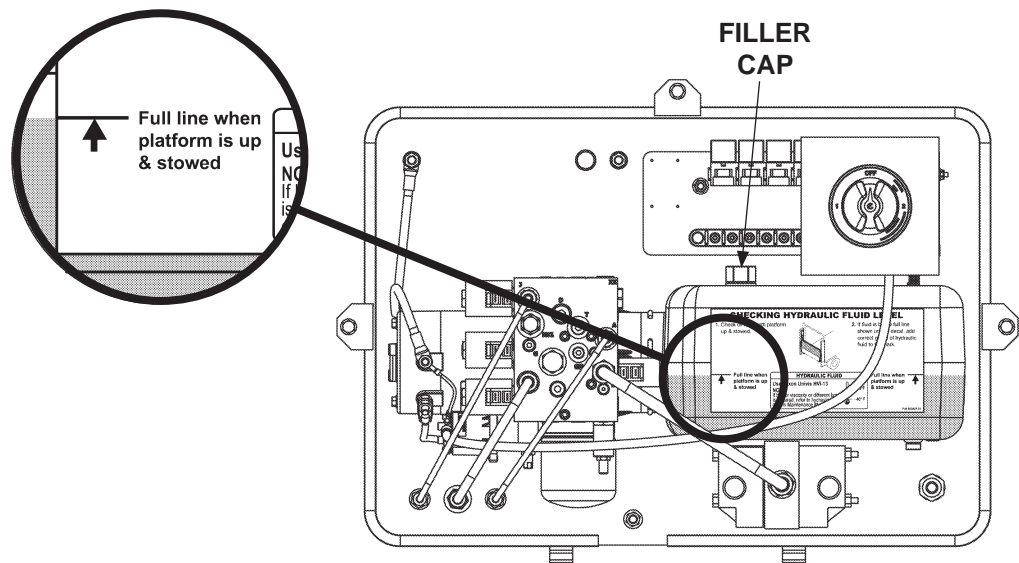

**CHECKING HYDRAULIC FLUID LEVEL
FIG. 66-1**

STEP 15 - CHECK MOUNTING BRACKET FIT

1. To check for interference between mounting bracket and stop block (FIG. 67-1A), lower columns to approximately 10" above the ground, then begin to unfold platform (FIG. 67-1).
2. As platform is unfolding, check for interference from the mounting bracket as it slides into the stop block (FIG. 67-1A).

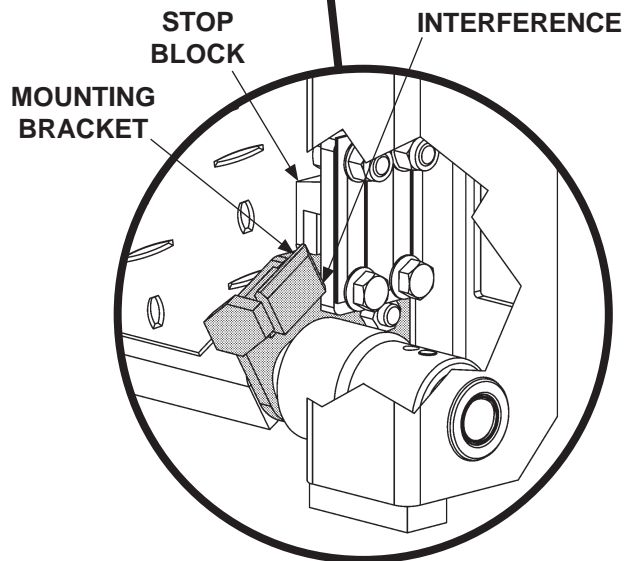
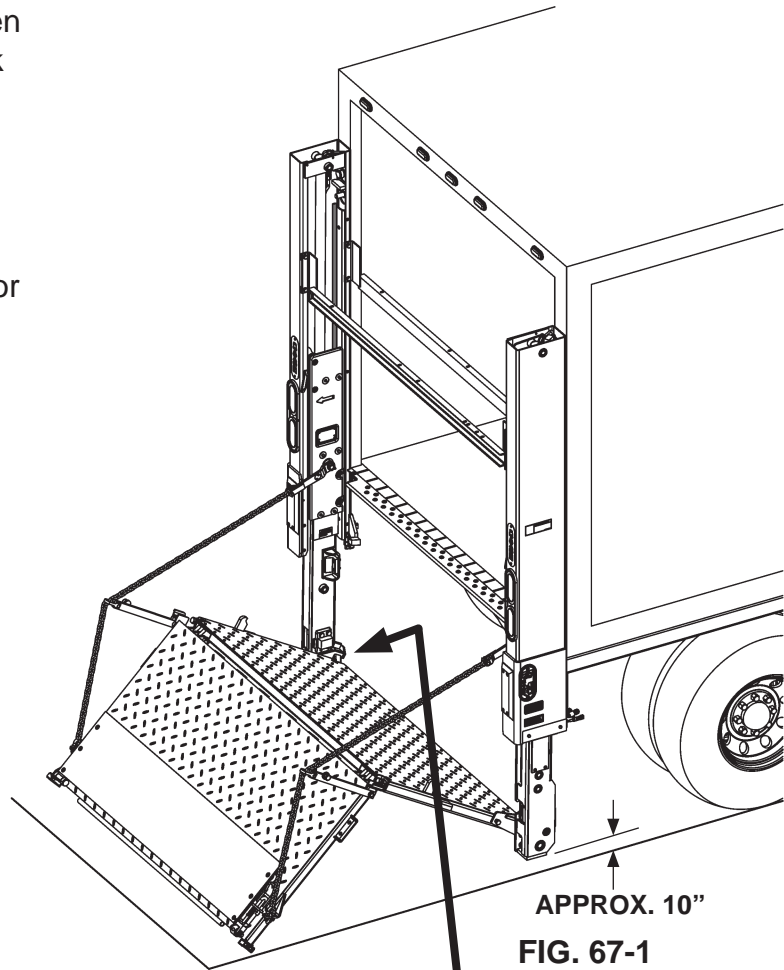

REAR VIEW OF LH RUNNER
FIG. 67-1A

STEP 15 - CHECK MOUNTING BRACKET FIT - Continued

NOTE: Perform this step only if folding operation is not smooth or there is interference (**FIG. 68-1B**).

3. If LH mounting bracket fits too tight against either side of stop block, operation is not smooth, or if there is interference (**FIG. 68-1A**) adjust with spacers as shown in **FIG. 68-1A**.
4. To adjust stop block, make sure platform is lowered to the ground (**FIG. 68-1**). Then, loosen (4) bolts (**FIGS. 68-1A and 68-1B**) and check gap (**FIG. 68-1A**). Add or remove shims (parts box) to fill or lessen the gap, then retighten bolts (**FIGS. 68-1A and 68-1B**).

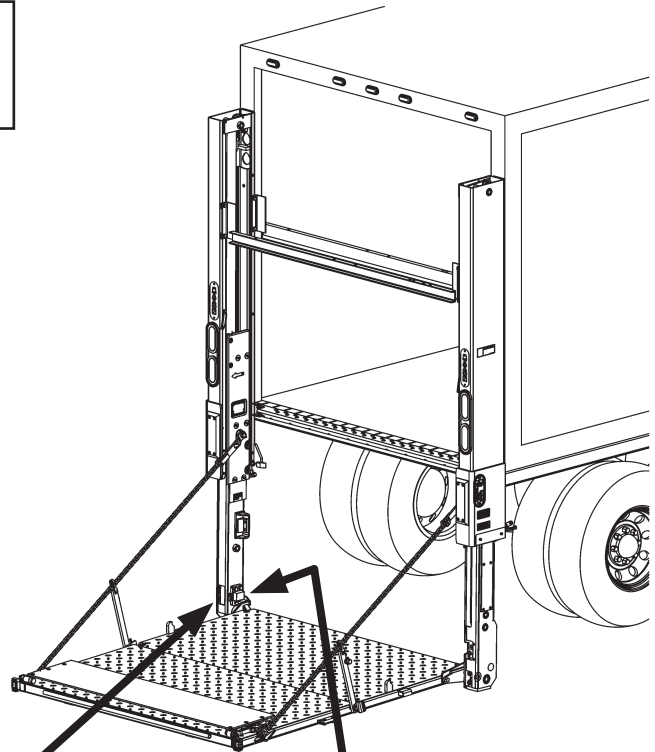
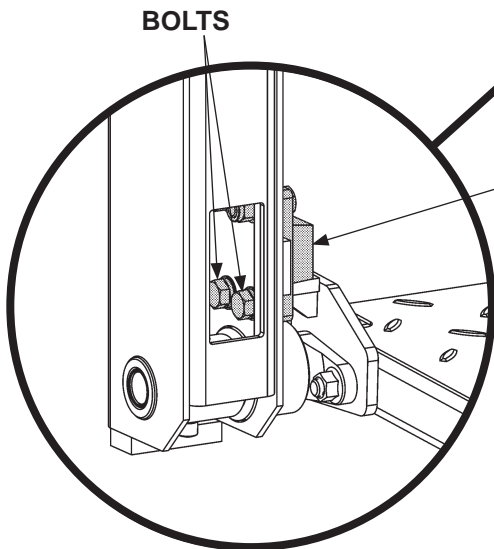
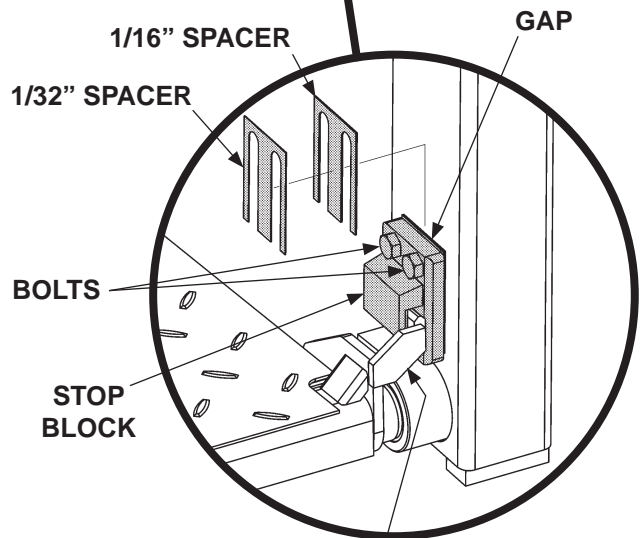

FIG. 68-1



**FRONT VIEW OF LH RUNNER
FIG. 68-1B**



MOUNTING BRACKET

**REAR VIEW OF LH RUNNER
FIG. 68-1A**

STEP 16 - REMOVE UPPER SUPPORT FIXTURES

⚠ CAUTION

Upper support fixtures are heavy. To prevent injury to installer and damage to Liftgate, use forklift or hoist to hold support fixtures during removal.

1. Stow the platform as shown in **FIG. 69-1**.
2. Position forklift or hoist to hold upper support fixtures as shown in **FIG. 69-1**.
3. Unbolt the 2 upper support fixtures from the LH column (**FIGS. 69-1 and 69-1A**). Repeat for RH column. Use forklift to remove upper support fixtures from work area.

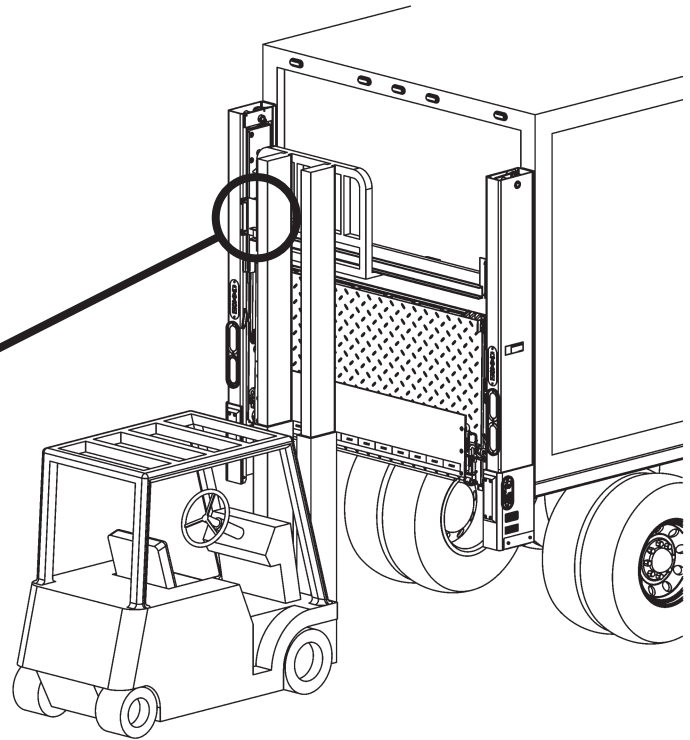
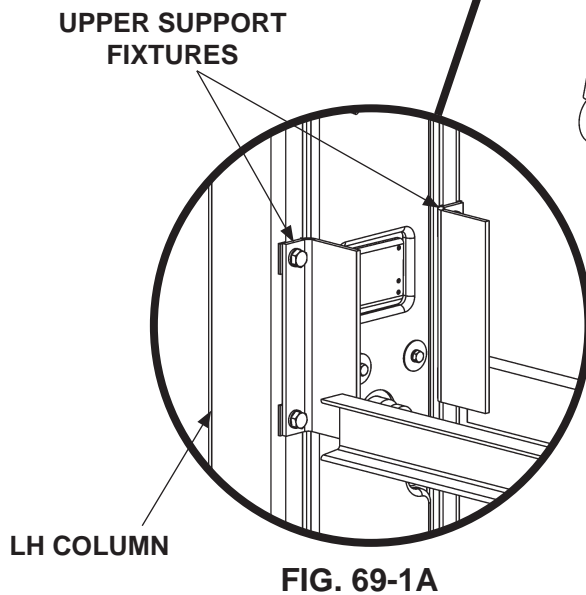

STEP 17 - SECURING COLUMNS METHOD 1 AND METHOD 2

NOTE: Skip this step if using the **Method 3** weld on version of installation with no mounting plates.

1. Slightly lower and open platform for access to mounting pin.
2. Get (2) lock plates and (2) 1"-8 lock nuts from parts bag. Then, install (1) lock plate and (1) lock nut to top rear guide on the mounting plate on the LH column (**FIGS. 70-1 and 70-1A**). Torque lock nut to **200 lb.-ft.** Repeat for RH column.

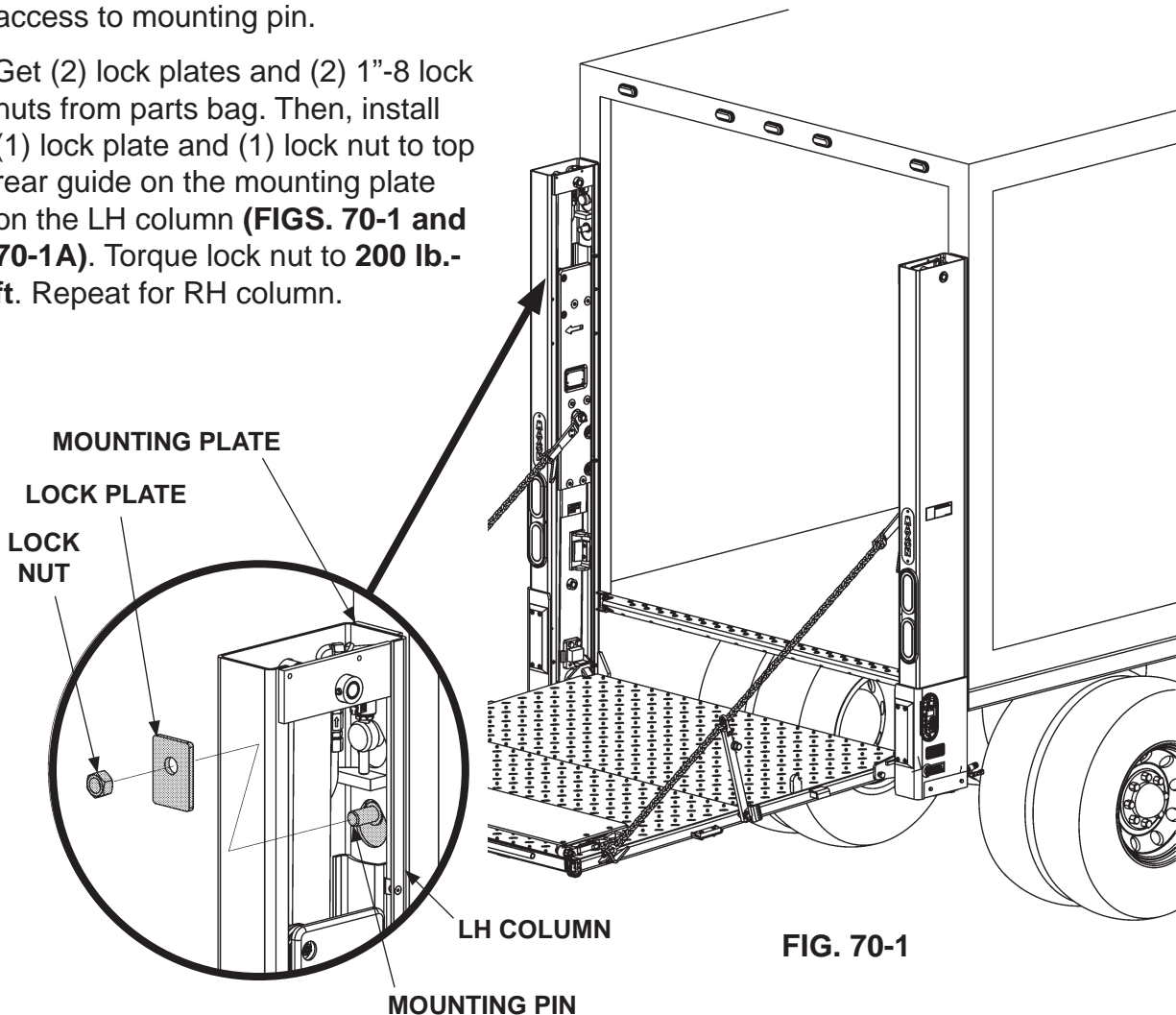

**INSTALLING LOCK PLATE
FIG. 70-1A**

STEP 17 - SECURING COLUMNS - Continued METHOD 1 AND METHOD 2

NOTE: Skip this step if using the **Method 3** weld on version of installation with no mounting plates.

3. Tighten cap screw against bolt guide in the LH column as shown in **(FIGS. 71-1 and 71-1A)** and torque to **170 lb.-ft.** Repeat for RH column.

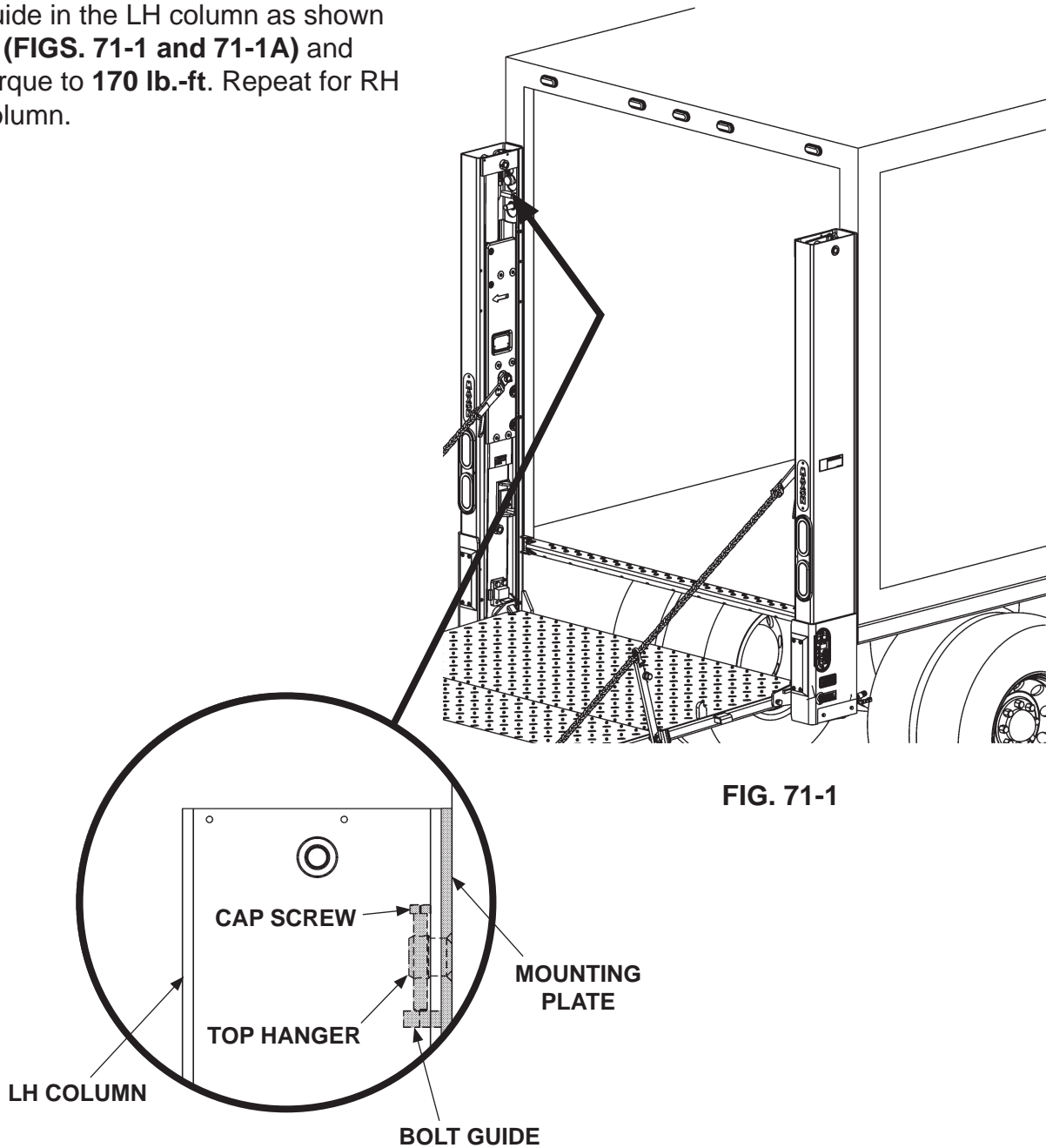

FIG. 71-1

TIGHTENING CAP SCREW
FIG. 71-1A

STEP 17 - SECURING COLUMNS - Continued

METHOD 1 AND METHOD 2

NOTE: Skip this step if using the **Method 3** weld on version of installation with no mounting plates.

NOTE: MAXON recommends using the upper bolt hole (**FIG. 72-1A**) to attach mounting plate. However, if the upper hole will be covered by vehicle corner post, then use the lower bolt hole (**FIG. 72-1B**).

4. Get (2) flange hex bolts, (2) flange lock nuts (if needed), and (2) flat washers (if needed) from parts bag. Then, install (1) bolt, (1) nut (if needed), and (1) flat washer (if needed) through mounting plate and RH column (**FIGS. 72-1, 72-1A and 72-1B**) Repeat for LH column.
5. Torque to **170 lb.-ft.** Repeat for LH column.

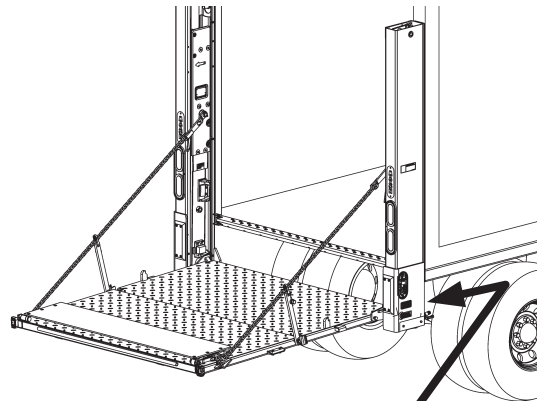
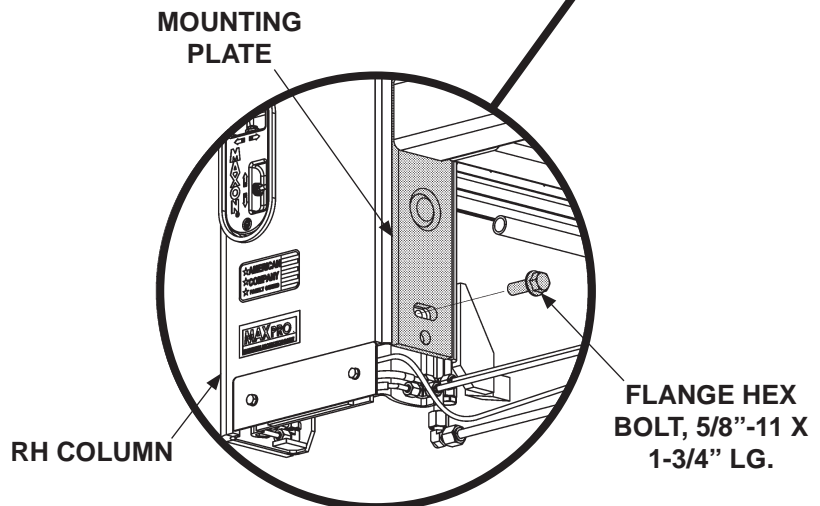
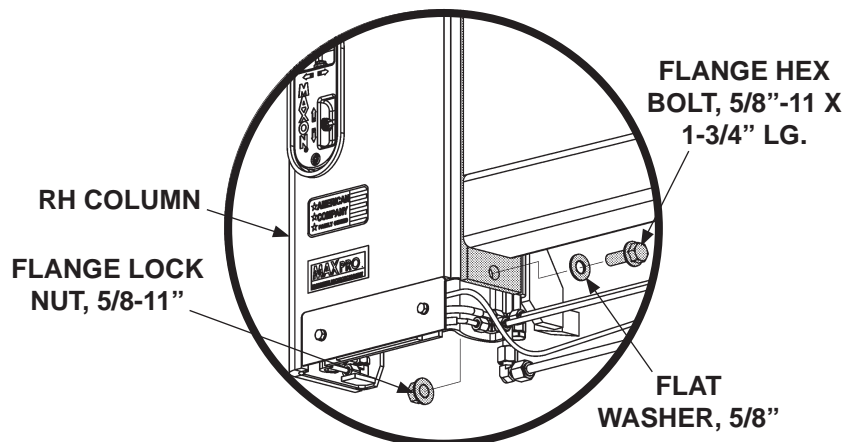

FIG. 72-1



UPPER BOLT HOLE
FIG. 72-1A

OR



LOWER BOLT HOLE
FIG. 72-1B

STEP 17 - SECURING COLUMNS - Continued

METHOD 1 AND METHOD 2

NOTE: Skip this step if using the **Method 3** weld on version of installation with no mounting plates, or **Method 1** version where the extension plate was already installed.

NOTE: Only use spacers if necessary.

6. Lower platform to access extension plate (**FIG. 73-1**).
7. Get the (4) cap screws, flat washers, locknuts and spacers that were removed in STEP 4. Then, reinstall (2) cap screws, flat washers, locknuts and spacers in the LH column and extension plate (**FIGS. 73-1 and 73-1A**). Repeat for the RH column and extension plate.

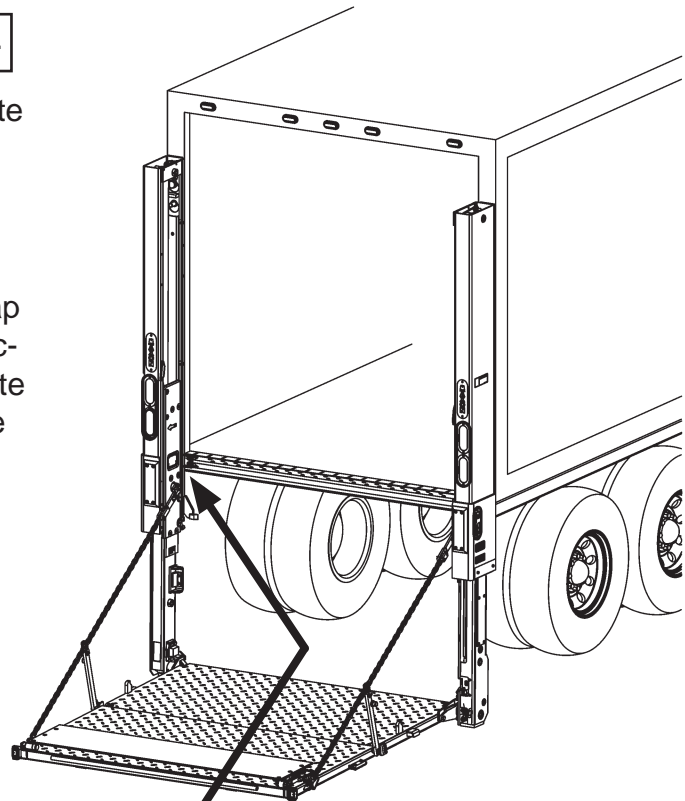

LOWERING LIFTGATE
FIG. 73-1

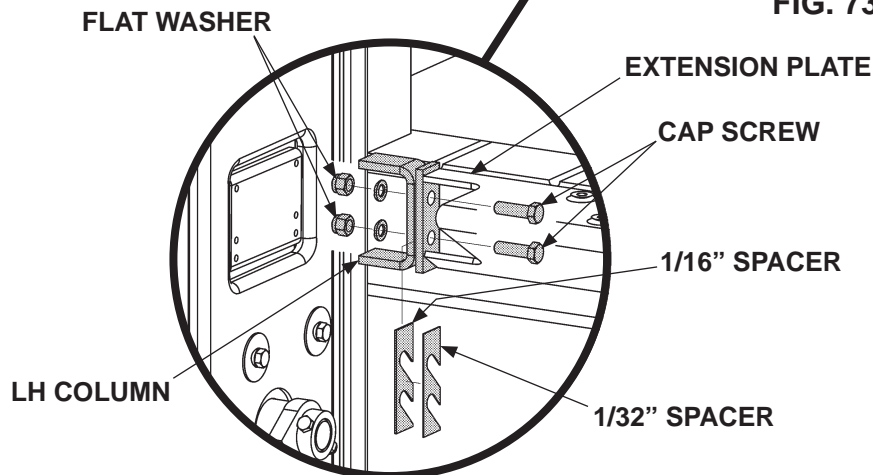

REINSTALLING HARDWARE
FIG. 73-1A

STEP 17 - SECURING COLUMNS - Continued METHOD 1 AND METHOD 2

NOTE: Skip this step if using the **Method 3** weld on version of installation with no mounting plates.

8. Reinstall RH top column cover, screws, lock washers and flat washers (**FIGS. 74-1 and 74-1A**). Tighten screws, then repeat for LH top column cover.

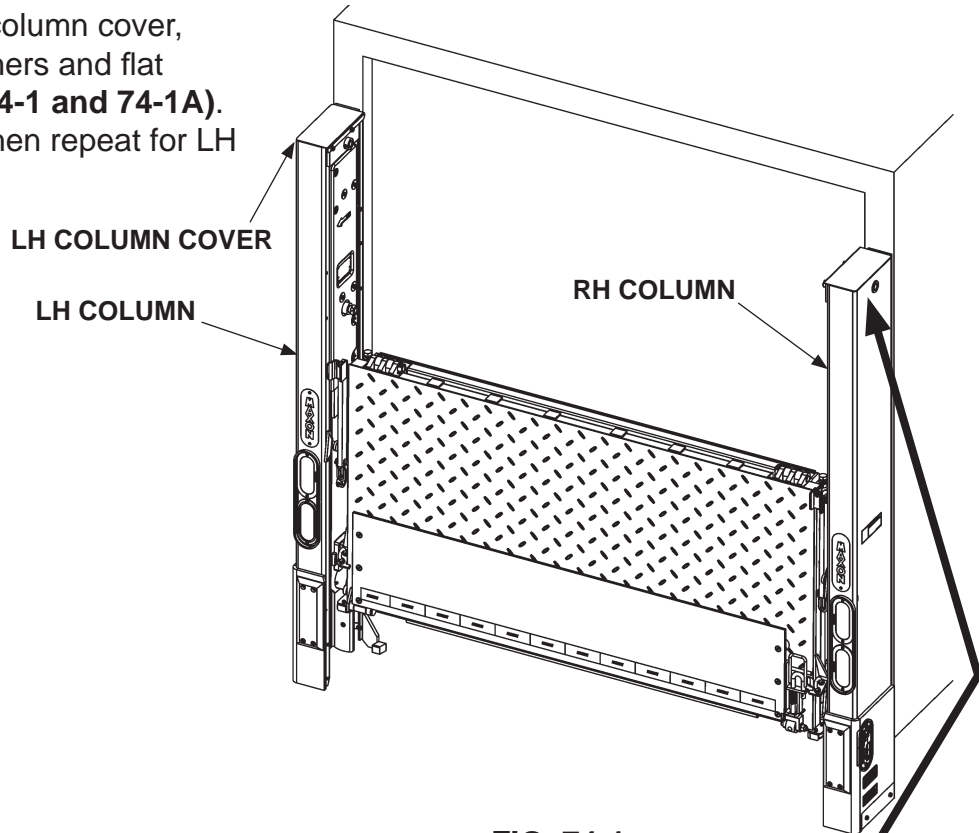
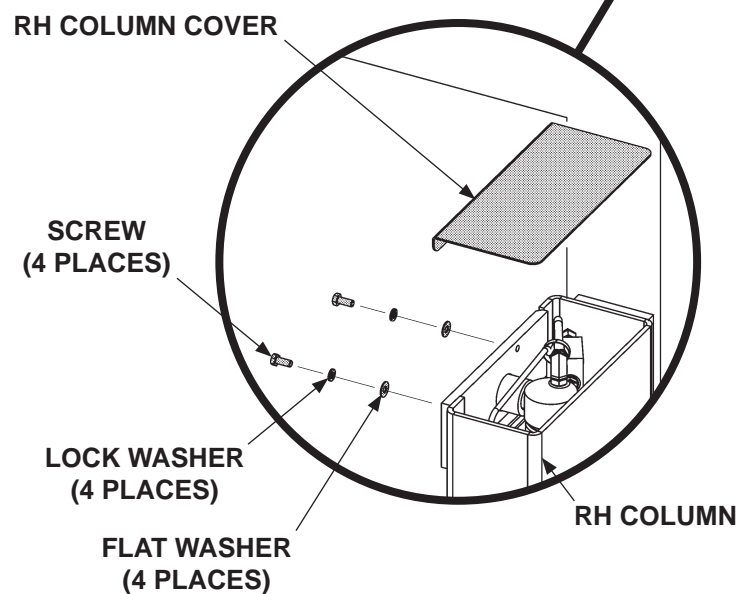

FIG. 74-1



REINSTALLING RH COLUMN COVER
FIG. 74-1A

STEP 18 - FINISH WELDING LIFTGATE TO VEHICLE METHOD 3 - WELD LIFTGATE TO BODY

NOTE: Skip this step if using **Method 1** or **Method 2** versions of installation where mounting plates and extension plate are preinstalled on the liftgate or vehicle.

1. Disconnect power from pump by removing nut from negative (-) battery terminal and disconnect negative (-) battery cable (**FIG. 75-1**). Reinstall nut on negative (-) battery terminal.

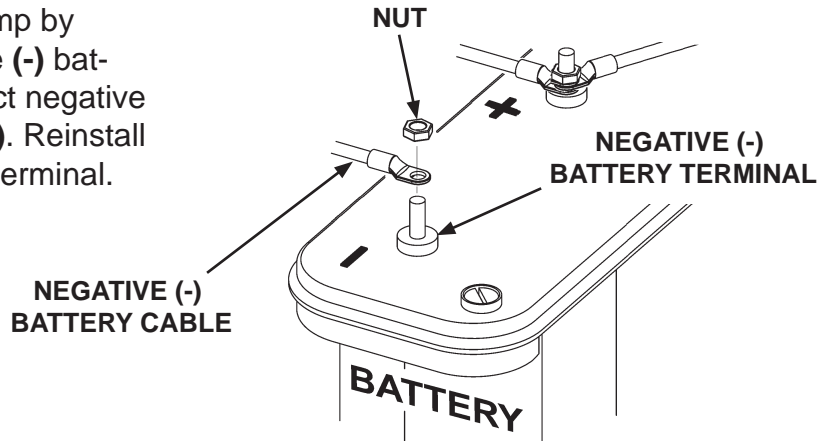

**DISCONNECTING POWER
FIG. 75-1**

STEP 18 - FINISH WELDING LIFTGATE TO VEHICLE METHOD 3 - WELD LIFTGATE TO BODY - Continued

⚠ WARNING

Recommended practices for welding on steel parts are contained in the current AWS (American Welding Society) D1.1 Structural Welding Code - Steel. Damage to Liftgate and/or vehicle, and personal injury can result from welds that are done incorrectly.

NOTE: Refer to **INSTALLED LIFTGATE** in the **VEHICLE REQUIREMENTS** section of this manual.

NOTE: If Liftgate columns cannot be mounted flush against rear of vehicle, a filler such as tubing, channel, or plate stock may be used to bridge gap between vehicle body and Liftgate columns. Make sure the added materials and welds meet the **BODY STRENGTH REQUIREMENTS** indicated in this manual.

CAUTION

To prevent damage to Liftgate, connect welder ground to vehicle body.

2. Cover platform as shown in **FIG. 76-1**.
3. Weld the Liftgate RH and LH columns to vehicle body as shown in **FIG. 76-1**.

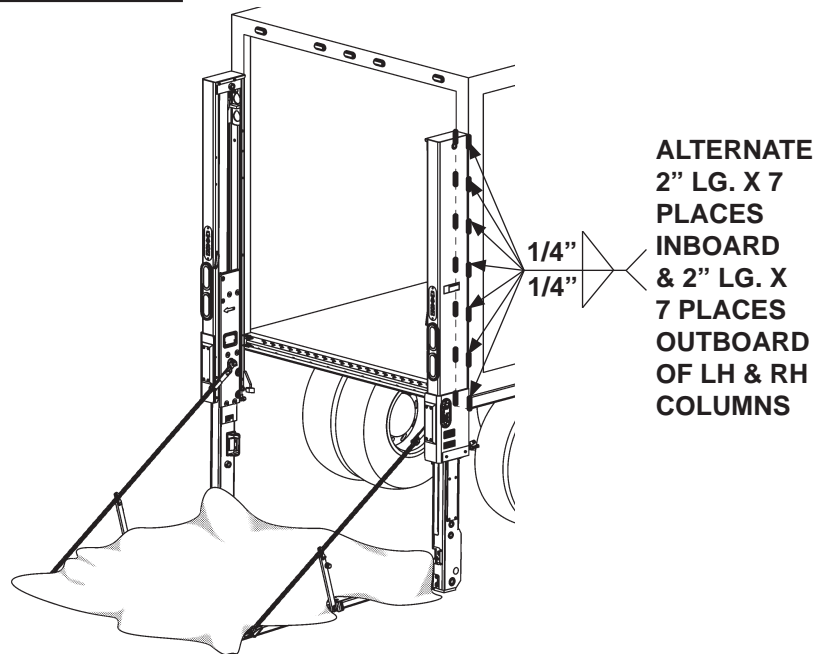

FIG. 76-1

STEP 18 - FINISH WELDING LIFTGATE TO VEHICLE

METHOD 3 - WELD LIFTGATE TO BODY - Continued

CAUTION

To prevent damage to Liftgate components, welder ground must be connected to Liftgate extension plate.

4. Make sure platform is at ground level to provide access to the extension plate.

NOTE: After welding top of extension plate, if you see a gap between bottom of extension plate & vehicle body sill, fill the gap. To fill the gap, use A-36 General Purpose steel and the same welds shown in **FIG. 77-2**.

5. Weld the top and bottom surfaces of extension plate (**FIGS. 77-1 & 77-2**) to vehicle body sill with 2" long welds centered every 8".
6. Weld entire length (**FIG. 77-2**) on the bottom of LH and RH end blocks.

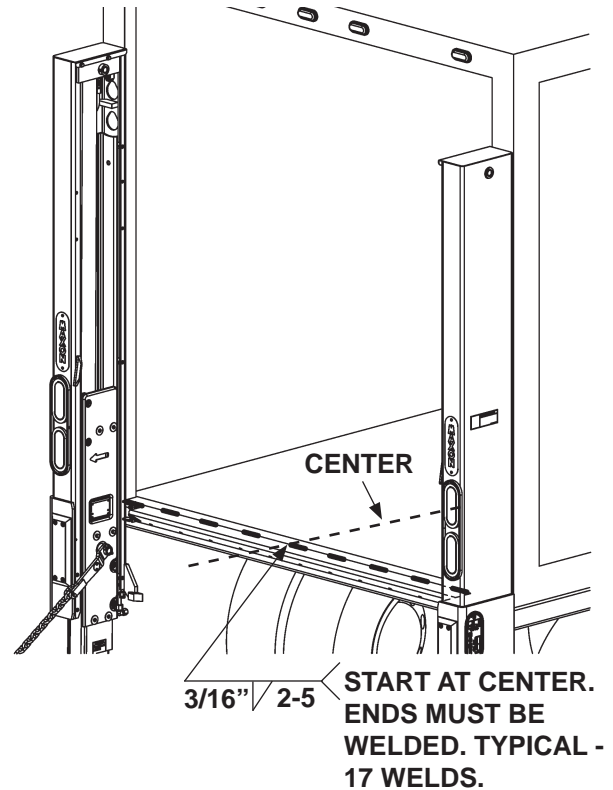

WELDING TOP OF EXTENSION PLATE
FIG. 77-1

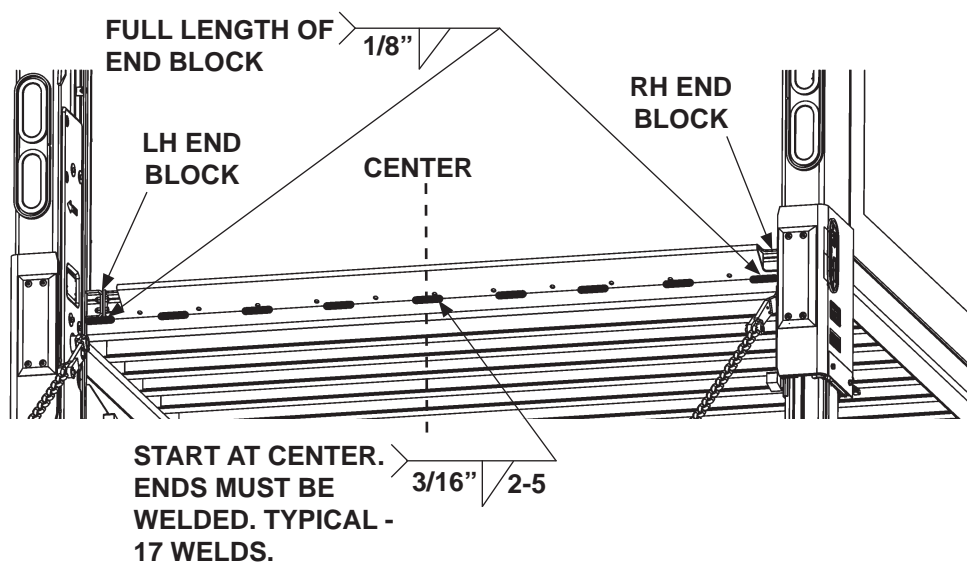

WELDING BOTTOM OF EXTENSION PLATE
FIG. 77-2

STEP 18 - FINISH WELDING LIFTGATE TO VEHICLE METHOD 3 - WELD LIFTGATE TO BODY - Continued

7. Reconnect negative (-) battery cable to negative (-) battery terminal (**FIG. 78-1**). Then, reinstall nut on negative (-) battery terminal (**FIG. 78-1**).

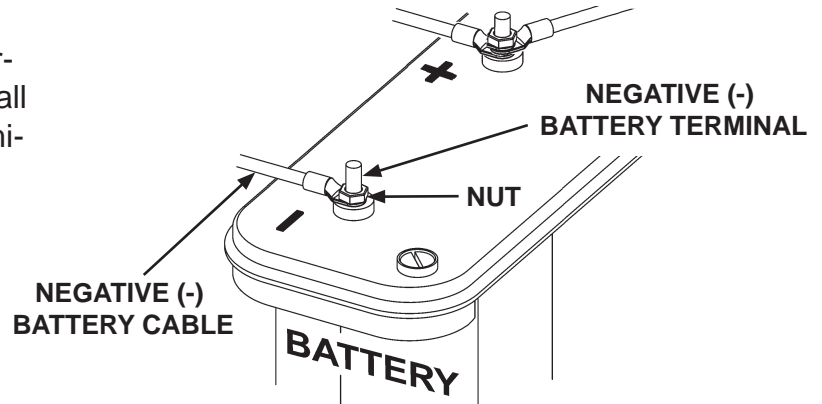

RECONNECTED BATTERY CABLES
FIG. 78-1

STEP 19 - PLATFORM CHAIN ADJUSTMENT

1. Lower the platform to ground level. Check if tip of the flipover and bottom of the runners touch the ground at the same time (**FIG. 79-1**).

2. If the bottom of the runners are off the ground, measure the distance "H1" (**FIG. 79-2**) from the ground to the bottom of the runners.

- Adjustment is not required if distance "H1" is 1" or less.
- If distance "H1" is more than 1", refer to the steps that follow to adjust the platform chains.

3. Refer to measured distance "H1" at the runners and **TABLE 79-1**. Note the method(s) that will be required to raise the tip of platform (or retention ramp) the expected distance.

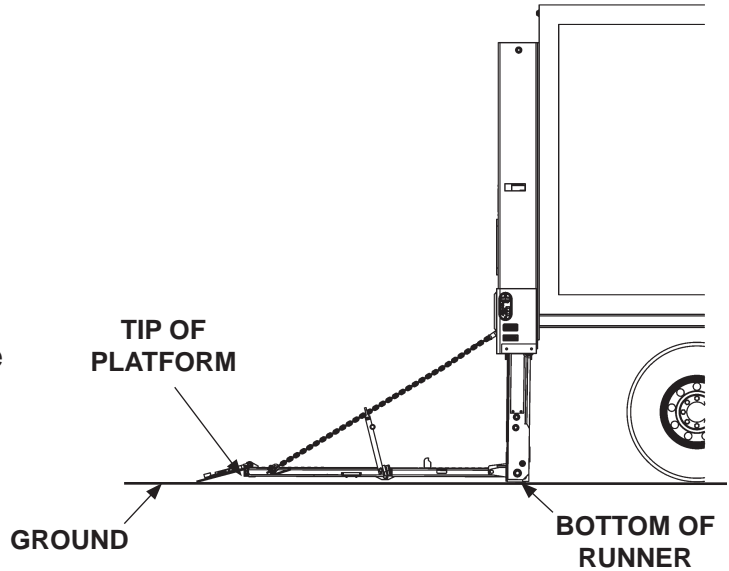

TIP AND RUNNER TOUCHING GROUND
FIG. 79-1

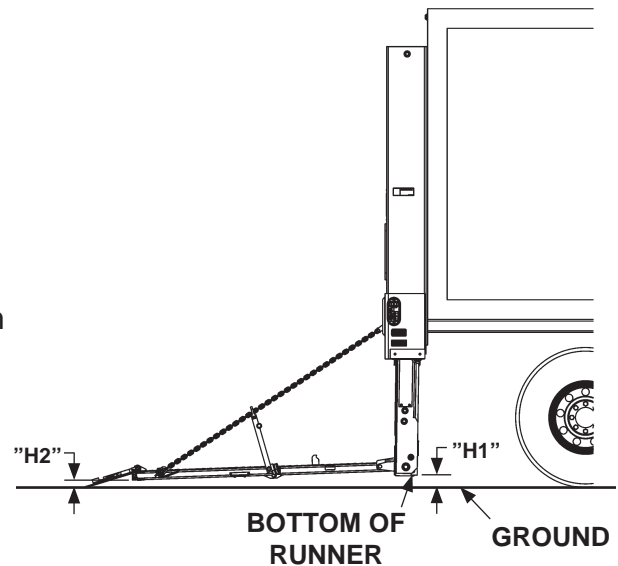

RUNNERS NOT TOUCHING
FIG. 79-2

MEASURED "H1" (AT RUNNER)	ADJUSTMENT METHODS (● REQUIRED FOR EXPECTED RISE AT TIP)		EXPECTED RISE "H2" (AT TIP)
	REMOVE 1 LINK OF BOTH CHAINS (RAISES TIP 1-1/2")	REMOVE 2 LINKS OF BOTH CHAINS (RAISES TIP 3")	
1" - 2-1/4"	-	-	0" - 1-1/4"
2-1/2" - 3-3/4"	●		1-1/2" - 2-3/4"
4"	●	●	3" - 4"

TABLE 79-1

STEP 19 - PLATFORM CHAIN ADJUSTMENT - Continued

4. Raise platform enough to remove supports. Then, lower platform to the ground (**FIG. 80-1**). Tip of flipover and runners should touch the ground at the same time as shown in **FIG. 80-1**. If necessary, repeat instructions **3 and 4** until tip of platform and runners touch ground at the same time.

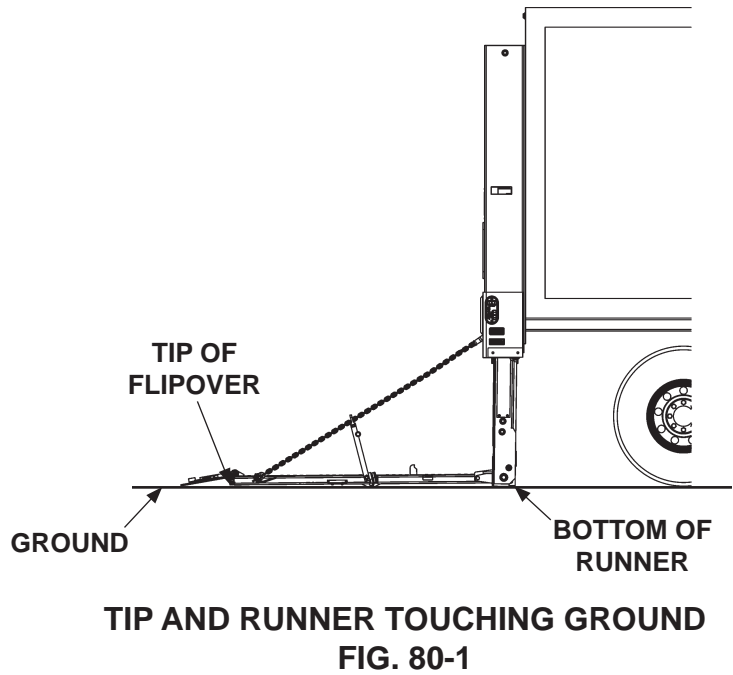

STEP 20 - PLACE "ALIGN ARROWS" DECAL

NOTE: Make sure **RUNNERS** are raised all the way up (closest to top of **COLUMN**) before doing the following steps.

Peel backing from alignment tape and place it on LH column as shown in **FIG. 81-1**. Repeat for RH column.

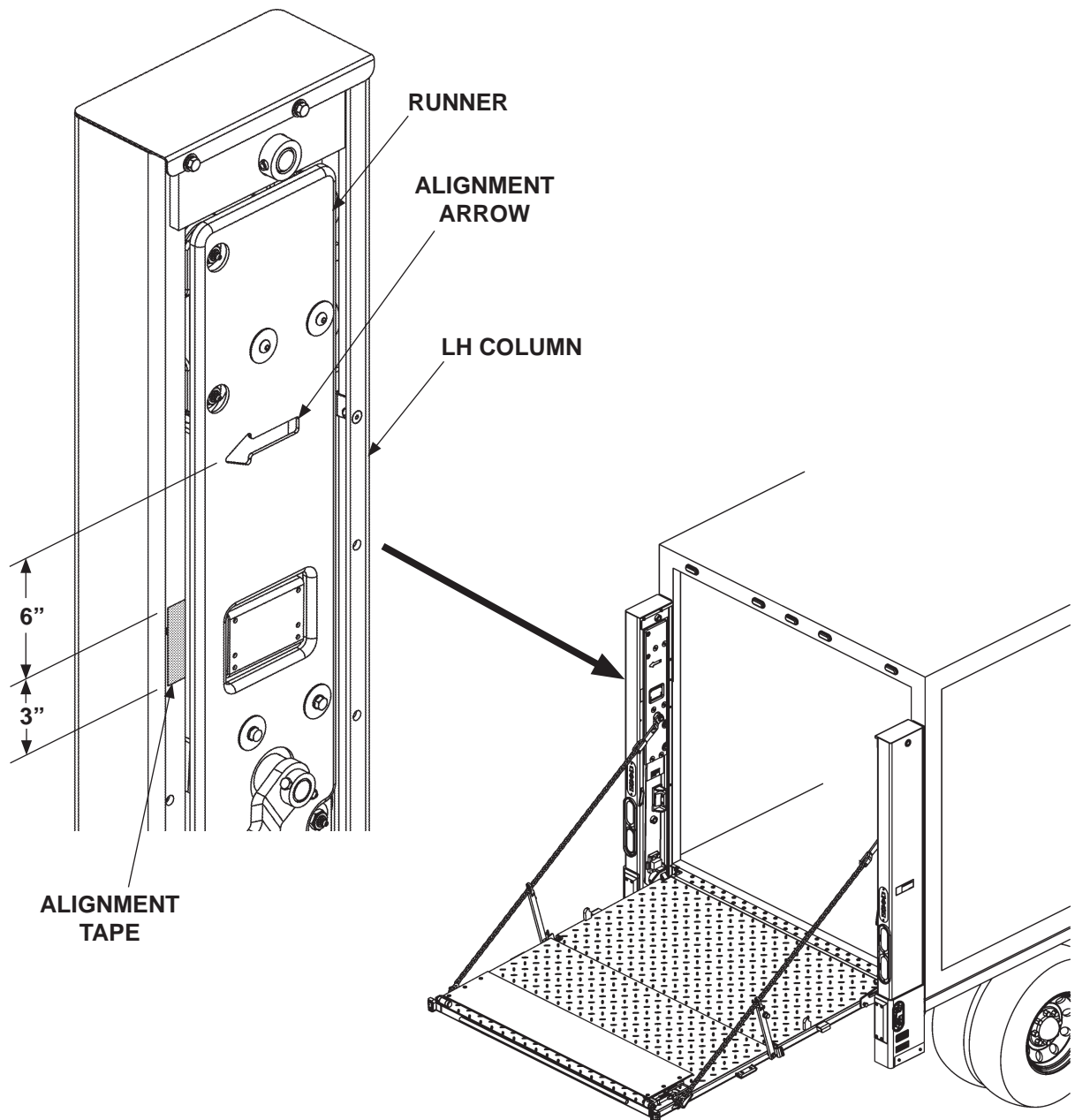

FIG. 81-1

STEP 21 - ADJUST PLATFORM ASSEMBLY

1. Ensure aluminum platform is completely unfolded (**FIG. 82-1**). Use long straight edge to determine if top surface of platform is flush with top surface of flipover as shown in **FIG. 82-1**.

NOTE: Recommend turning bolt in 60° increments so flats of the adjuster bolt are parallel to vertical surface of side plates.

2. If flipover requires adjustment, fold platform enough to gain access to adjustment bolt on each side of platform (**FIG. 82-2**). Next, loosen locking nut for each adjuster bolt (**FIG. 82-2**). Then, alternately turn each bolt clockwise to raise tip of flipover or counter-clockwise to lower tip of flipover. Repeat 1 to check. When platform and flipover are flush, torque both locking nuts to **192 lb-ft**.

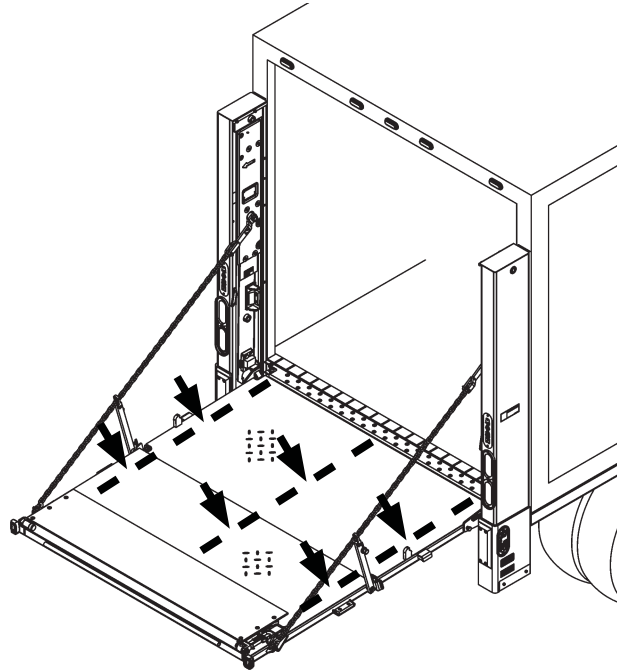

ARROWS INDICATE WHERE TO CHECK IF PLATFORM & FLIPOVER ARE FLUSH
FIG. 82-1

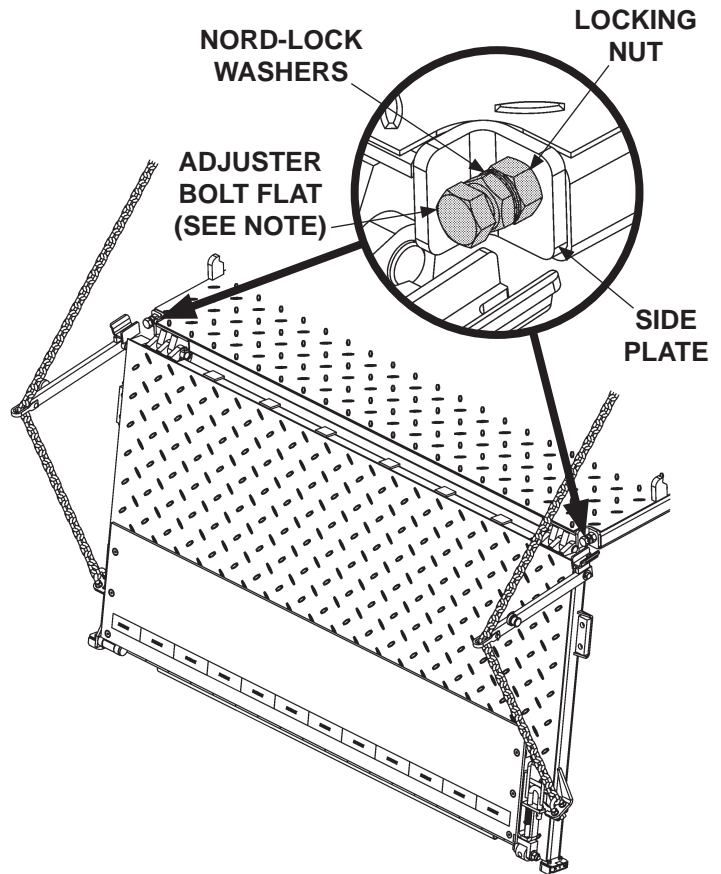

PLATFORM ADJUSTMENT BOLT
FIG. 82-2

STEP 22 - ACTIVATE PLATFORM LIGHTS

1. Activate the flashing platform lights by cutting the wire from the center of the link wire on both RH and LH flashing lights (**FIG. 83-1**).

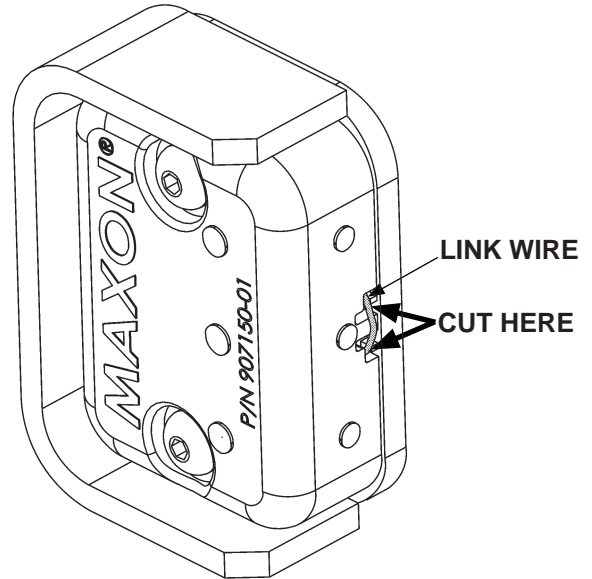

2. Fold platform. Lights should stop flashing.

ACTIVATING PLATFORM LIGHTS
FIG. 83-1

ATTACH DECALS

NOTE: Ensure there is no residue, dirt, or corrosion where decals are attached. If necessary, clean surface before attaching decals.

NOTE: Preferred decal layout is shown. Decals on the Liftgate are attached at the factory. If vehicle does not permit this layout, decals in the manual and decal kit must be applied so that they are easily visible when approaching vehicle to operate Liftgate. Use good common sense when locating these decals on vehicle.

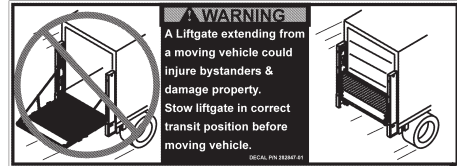

STOW WARNING DECAL
P/N 282847-01

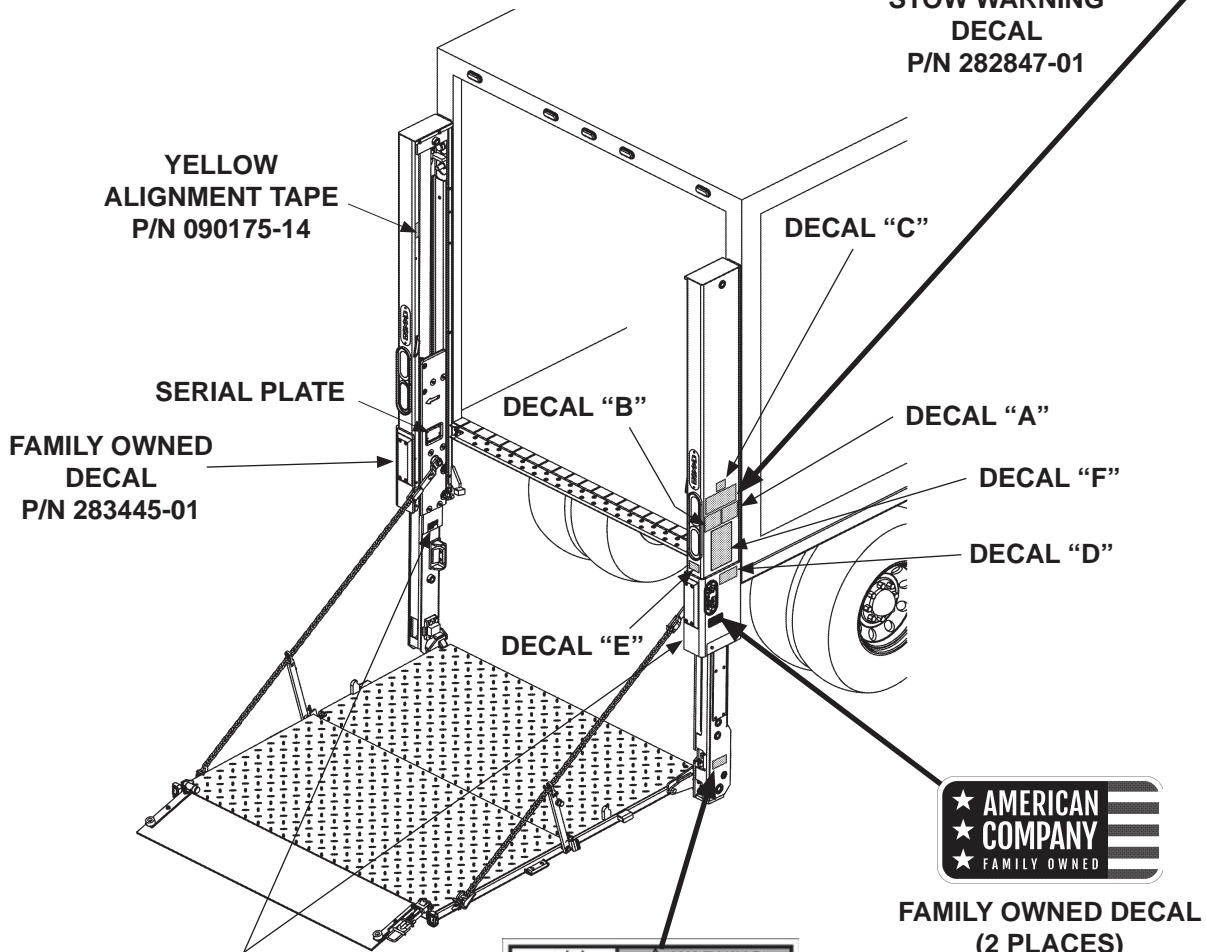

FAMILY OWNED DECAL (2 PLACES)
P/N 283445-01



CAUTION DECAL (2 PLACES)
P/N 260552

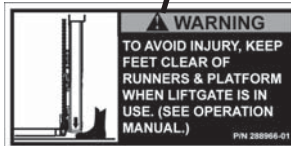

WARNING DECAL
P/N 288966-01

FIG. 84-1

DECALS - Continued

⚠ WARNING
Read this information carefully.

- Improper operation of this Liftgate can result in serious personal injury. If you do not have a copy of the operating instructions, please obtain them from your employer, distributor, or lessor before you attempt to operate Liftgate.
- If there are signs of improper maintenance, damage to vital parts, or slippery platform surface, do not use the Liftgate until these problems have been corrected.
- If you are using a pallet jack, be sure it can be maneuvered safely.
- Do not operate a forklift on the platform.
- Do not allow any part of yours or your helper's body to be placed under, within, or around any portion of the moving Liftgate, or its mechanisms, or in a position that would trap them between the platform and the ground or truck when the Liftgate is operated.
- If a helper is riding the platform with you, make sure you are both doing so safely and that you are not in danger of coming in contact with any moving or potentially moving obstacles.
- **USE GOOD COMMON SENSE.**
- If load appears to be unsafe, do not lift or lower it.

For a free copy of other manuals that pertain to this model Liftgate, please visit our website at www.maxonlift.com or call Customer Service at (800) 227-4116.

B

⚠ WARNING

Liftgate hazards can result in crushing or falling.

Keep hands and feet clear of pinch points.

If riding liftgate, make sure load is stable and footing is solid.

Read and understand all instructions and WARNINGS before use.

D

SAFETY INSTRUCTIONS

Read all decals and operation manual before operating liftgate.

1. Do not use liftgate unless you have been properly instructed and have read, and are familiar with, the operating instructions.
2. Be certain vehicle is properly and securely braked before using the liftgate.
3. Always inspect this liftgate for maintenance or damage before using it. Do not use liftgate if it shows any sign of damage or improper maintenance.
4. Do not overload
5. Make certain the area in which the platform will open and close is clear before opening or closing the platform.
6. Make certain platform area, including the area in which loads may fall from platform, is clear before and at all times during operation of liftgate.
7. This liftgate is intended for loading and unloading of cargo only. Do not use this liftgate for anything but its intended use.

A

THE MAXIMUM CAPACITY OF THIS LIFT IS

___ LB [___ KG]

WHEN THE LOAD IS CENTERED ON THE LOAD CARRYING PLATFORM

C

(REFER TO TABLE 85-1)

⚠ CAUTION

Always stand clear of platform area.

E

OPERATING INSTRUCTIONS

OPERATE	STOW
<p>1 LOWER RUNNERS TO LINE UP YELLOW ARROW WITH YELLOW STRIPE. THIS SHOWS PLATFORM IS CLEAR TO UNFOLD.</p>	<p>1 RAISE PLATFORM TO LINE UP YELLOW ARROW WITH YELLOW STRIPE. THIS SHOWS PLATFORM IS CLEAR TO FOLD.</p>
<p>2 UNFOLD PLATFORM.</p>	<p>2 FOLD PLATFORM.</p>
<p>3 1 - LOWER PLATFORM. IF IT IS SLOW TO LOWER & LIFTGATE IS POWER DOWN EQUIPPED, PUSH POWER DOWN BUTTON. 2 - RAISE PLATFORM. POWER DOWN BUTTON (IF EQUIPPED)</p>	<p>3 RAISE RUNNERS TO STOW PLATFORM.</p>

P/N 289163-01 **F**

**DECAL SHEET
 FIG. 85-1**

MODEL	ORDER P/N	DECAL "C"
BMR-35	289163-01	3500 LBS. [1600 KG]
BMR-44	289163-02	4400 LBS. [2000 KG]
BMR-55	289163-03	5500 LBS. [2500 KG]
BMR-66	289163-04	6600 LBS. [3000 KG]

**DECAL SHEET PART NUMBERS
 TABLE 85-1**

11921 Slauson Ave. Santa Fe Springs, CA. 90670 (800) 227-4116 FAX (888) 771-7713

MAXON

TOUCH UP GALVANIZED FINISH

CAUTION

Damaged cylinder seals and contaminated hydraulic fluid can result from painting the polished portion of the cylinder rod. To prevent damage, protect the exposed polished portion of the cylinder rod while painting.

- If bare metal is exposed on galvanized portions of the Liftgate, touch up the galvanized finish. To maintain the protection provided by the original galvanized finish, **MAXON** recommends cold galvanize spray, **P/N 908000-01**.

OPTIONS

RECOMMENDED LIFTGATE POWER CONFIGURATION

NOTE: Make sure the Liftgate power unit, and all batteries on the vehicle for the power unit, are connected correctly to a common chassis ground.

1. Liftgate, pump box, and battery box are typically installed on trailers as shown in **FIG. 87-1**.

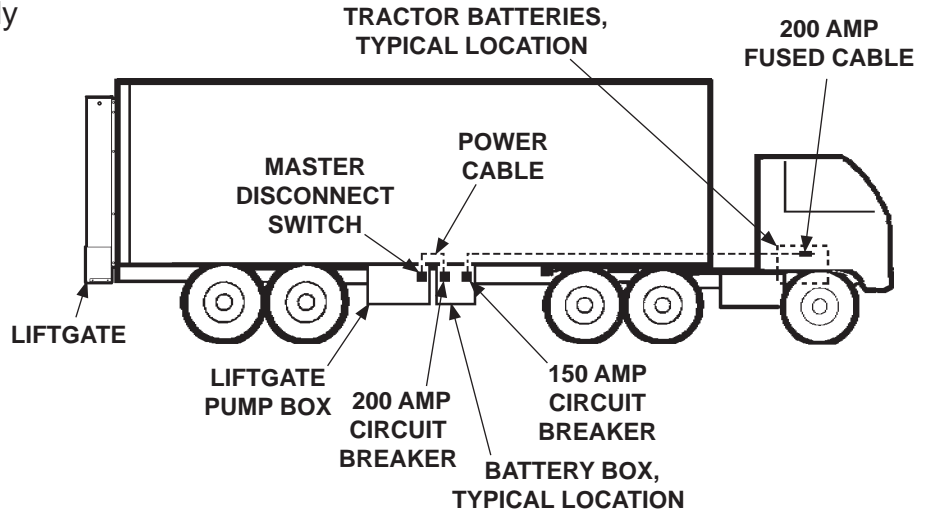

**RECOMMENDED LIFTGATE & BATTERY BOX
INSTALLATION ON TRAILER
FIG. 87-1**

OPTIONS

RECOMMENDED LIFTGATE POWER CONFIGURATION - Continued

NOTE: Make sure the Liftgate power unit, and all batteries on the vehicle for the power unit, are connected correctly to a common chassis ground.

2. Liftgate, pump box, and optional battery box are typically installed on trucks as shown in **FIG. 88-1** and **FIG. 88-2**. See the following page for battery and cable connections.

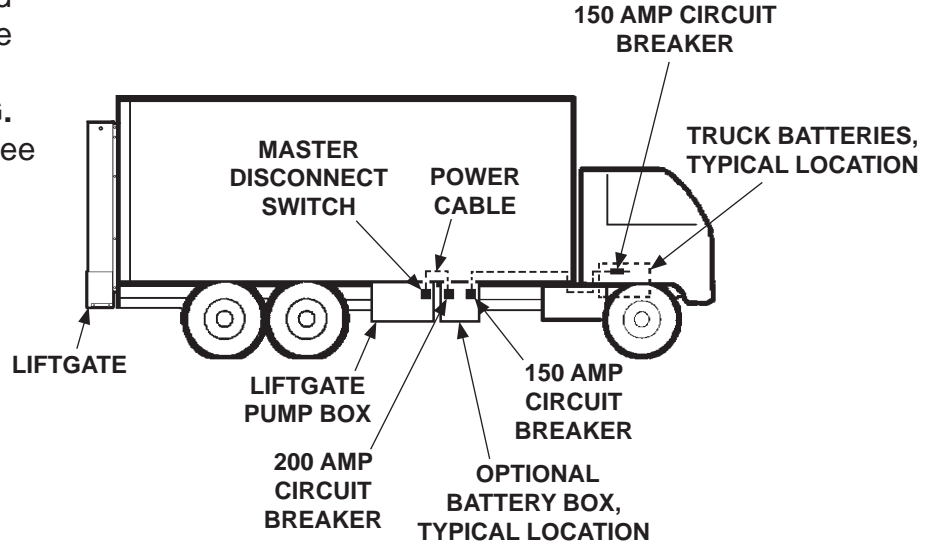

**RECOMMENDED LIFTGATE & BATTERY BOX
INSTALLATION ON TRUCK**

FIG. 88-1

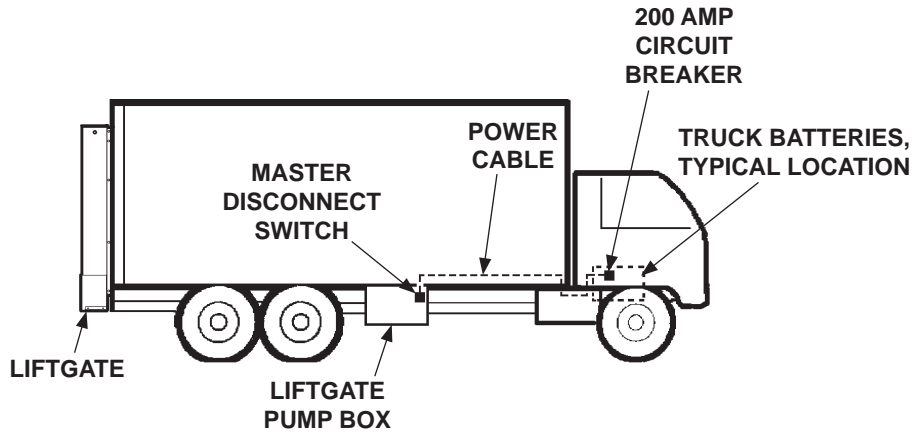

**RECOMMENDED LIFTGATE
INSTALLATION ON TRUCK**

FIG. 88-2

MAXON® 11921 Slauson Ave. Santa Fe Springs, CA. 90670 (800) 227-4116 FAX (888) 771-7713

HYDRAULIC SYSTEM DIAGRAMS

PUMP & MOTOR SOLENOID OPERATION - POWER DOWN

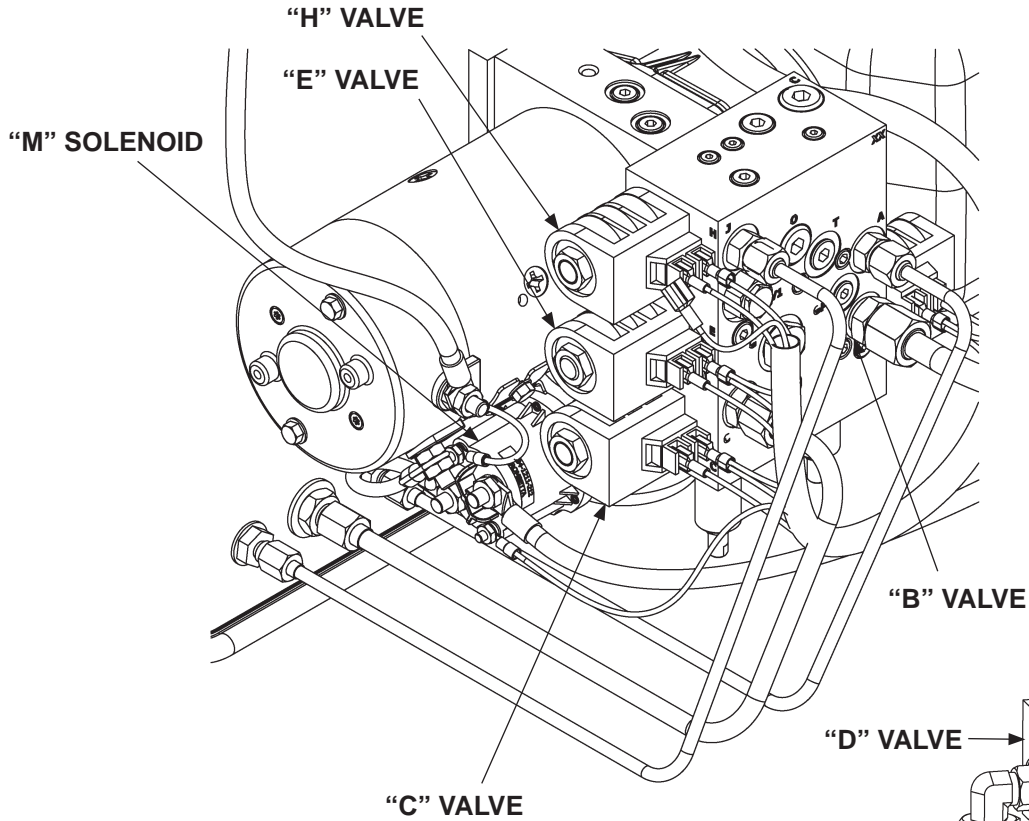
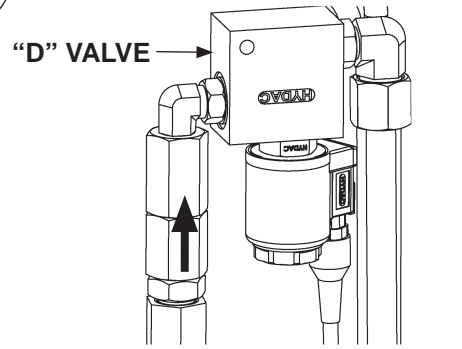

FIG. 89-1



**"D" VALVES
(TOP OF EACH COLUMN)**

FIG. 89-2

POWER UNIT MOTOR & SOLENOID OPERATION - POWER DOWN									
LIFTGATE FUNCTION	PORT	SOLENOID OPERATION (✓ MEANS ENERGIZED)							
		SWITCH	RELAY	MOTOR	VALVE "B"	VALVE "C"	VALVE "D"	VALVE "E"	VALVE "H"
LIFT	B	"PD"	-	✓	-	-	-	-	-
LOWER	C		-	✓	✓	✓	✓	-	-
OPEN	J		-	✓	-	-	-	✓	✓
CLOSE	A		-	✓	-	-	-	✓	-

REFER TO VALVES SHOWN ON HYDRAULIC SCHEMATIC

TABLE 89-1

HYDRAULIC SYSTEM DIAGRAMS

PUMP & MOTOR SOLENOID OPERATION - GRAVITY DOWN

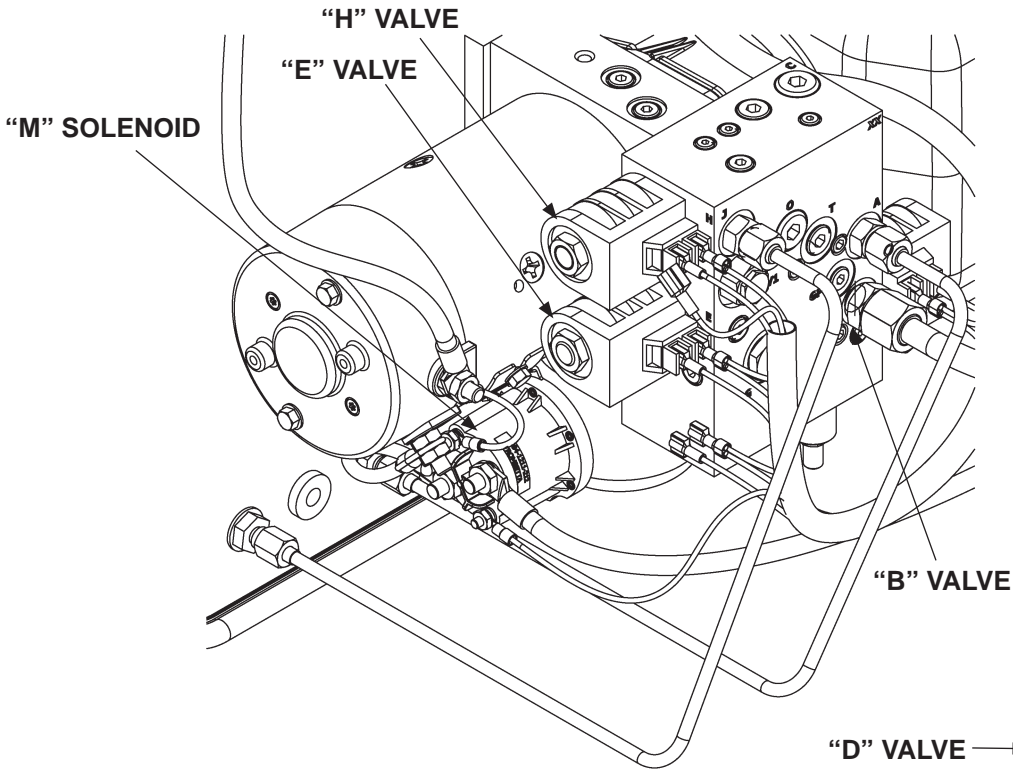
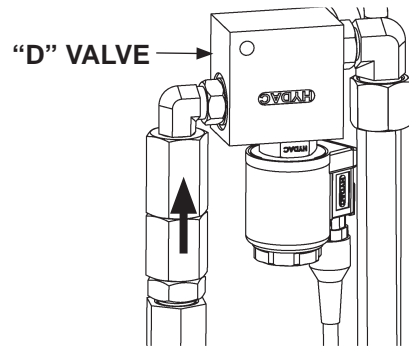

FIG. 90-1



"D" VALVES
(TOP OF EACH COLUMN)
FIG. 90-2

POWER UNIT MOTOR & SOLENOID OPERATION - GRAVITY DOWN									
LIFTGATE FUNCTION	PORT	SOLENOID OPERATION (✓ MEANS ENERGIZED)							
		SWITCH	RELAY	MOTOR	VALVE "B"	VALVE "C"	VALVE "D"	VALVE "E"	VALVE "H"
LIFT	B	"GD"	-	✓	-	-	-	-	-
LOWER	C		✓	-	✓	-	✓	-	-
OPEN	J		-	✓	-	-	-	✓	✓
CLOSE	A		-	✓	-	-	-	✓	-
REFER TO VALVES SHOWN ON HYDRAULIC SCHEMATIC									

TABLE 90-1

HYDRAULIC SYSTEM DIAGRAMS

GRAVITY DOWN HYDRAULIC SCHEMATIC

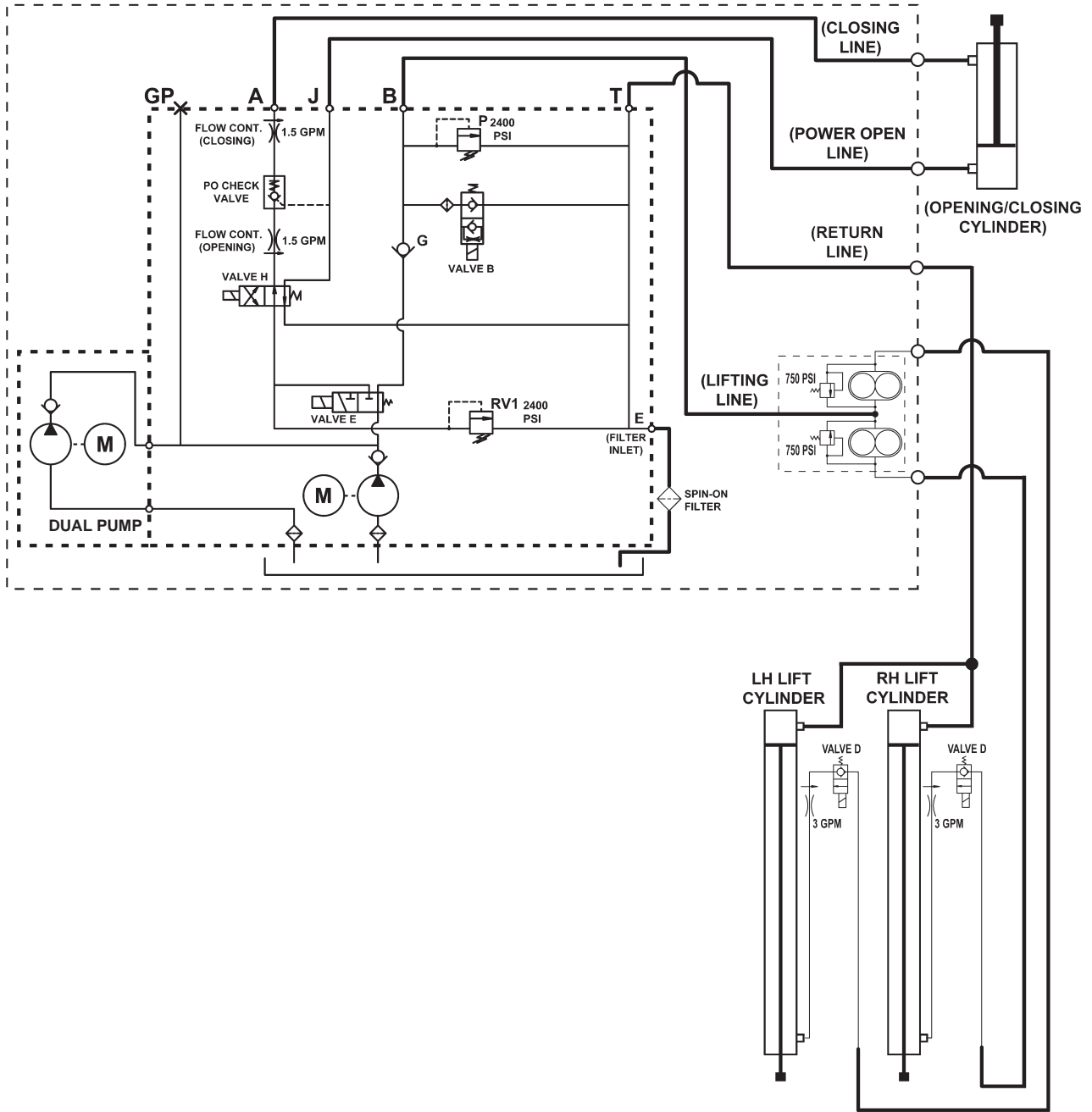

FIG. 91-1

HYDRAULIC SYSTEM DIAGRAMS

POWER DOWN HYDRAULIC SCHEMATIC

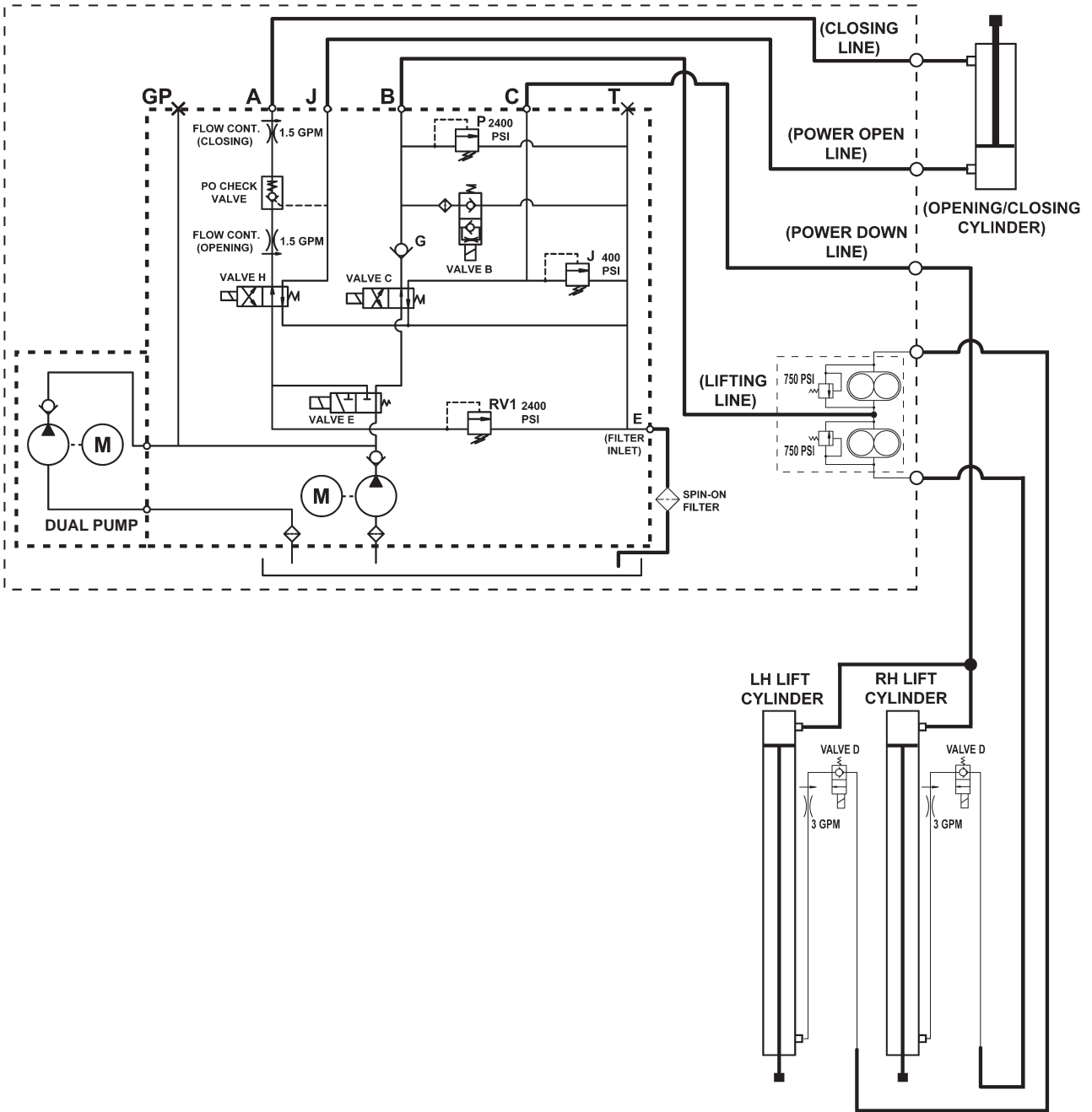

FIG. 92-1

ELECTRICAL SYSTEM DIAGRAMS

GRAVITY DOWN SINGLE PUMP ELECTRICAL SCHEMATIC

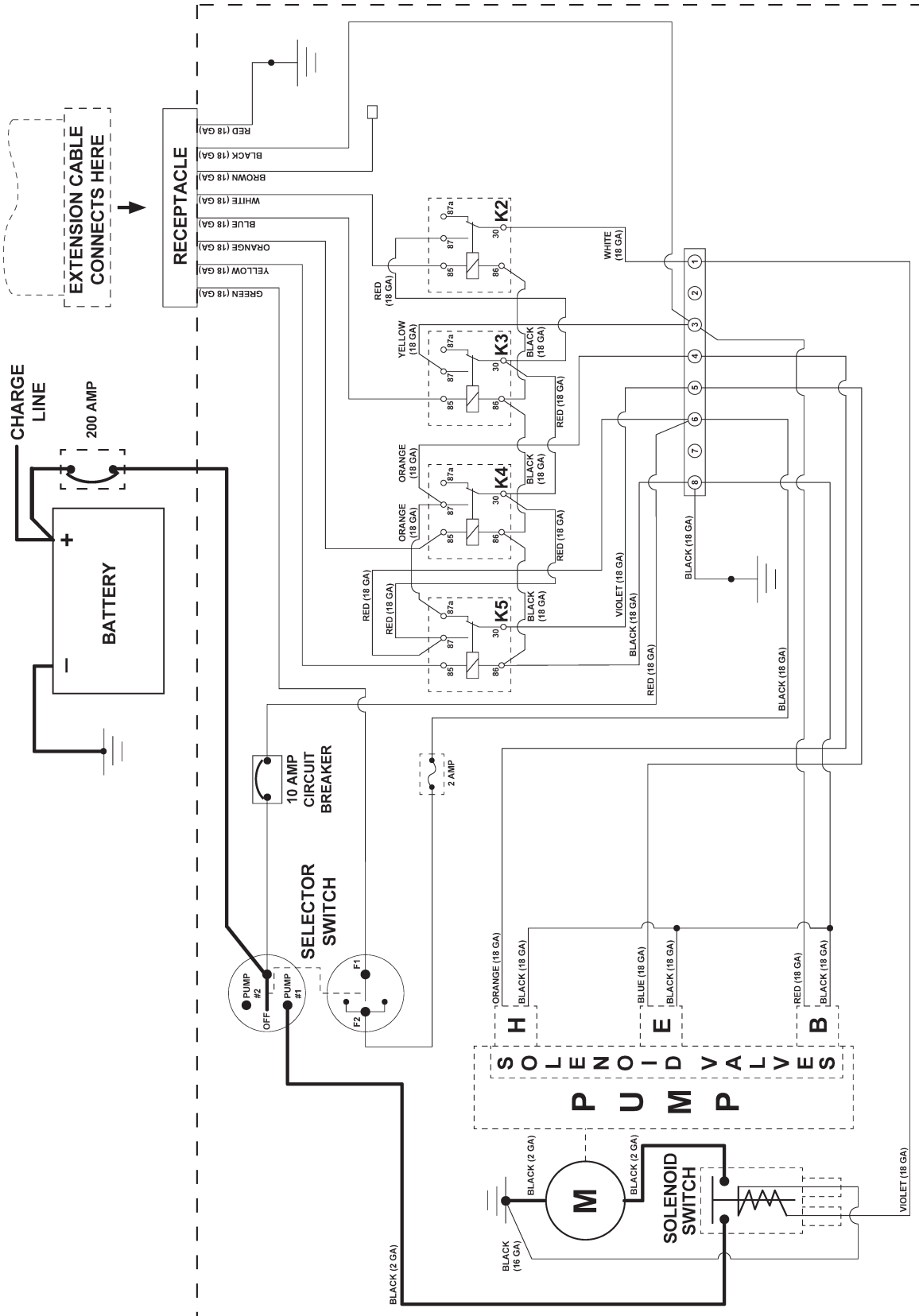

FIG. 94-1

ELECTRICAL SYSTEM DIAGRAMS

GRAVITY DOWN DUAL PUMP ELECTRICAL SCHEMATIC

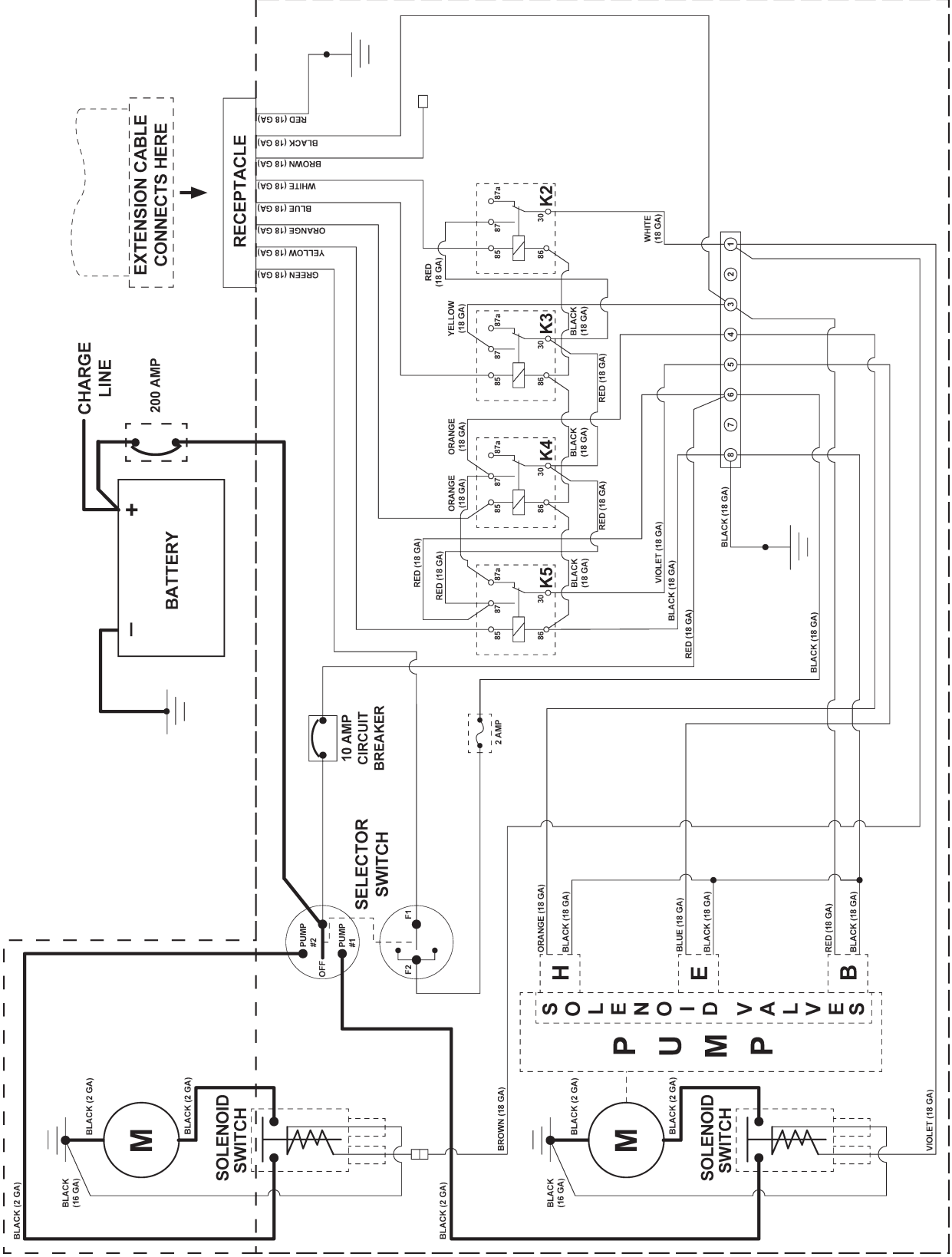

FIG. 95-1

ELECTRICAL SYSTEM DIAGRAMS

POWER DOWN SINGLE PUMP ELECTRICAL SCHEMATIC

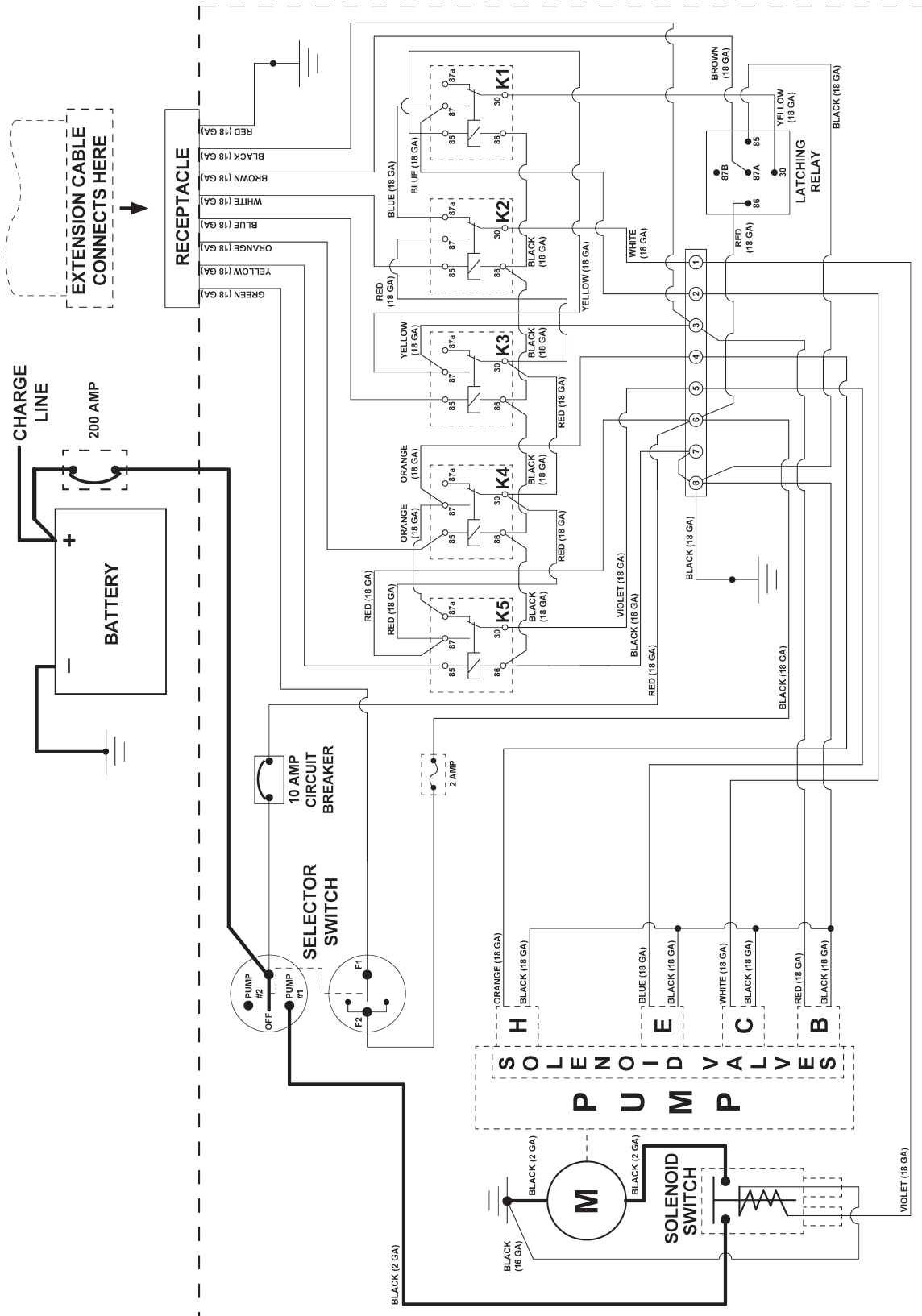

FIG. 96-1

ELECTRICAL SYSTEM DIAGRAMS

POWER DOWN DUAL PUMP ELECTRICAL SCHEMATIC

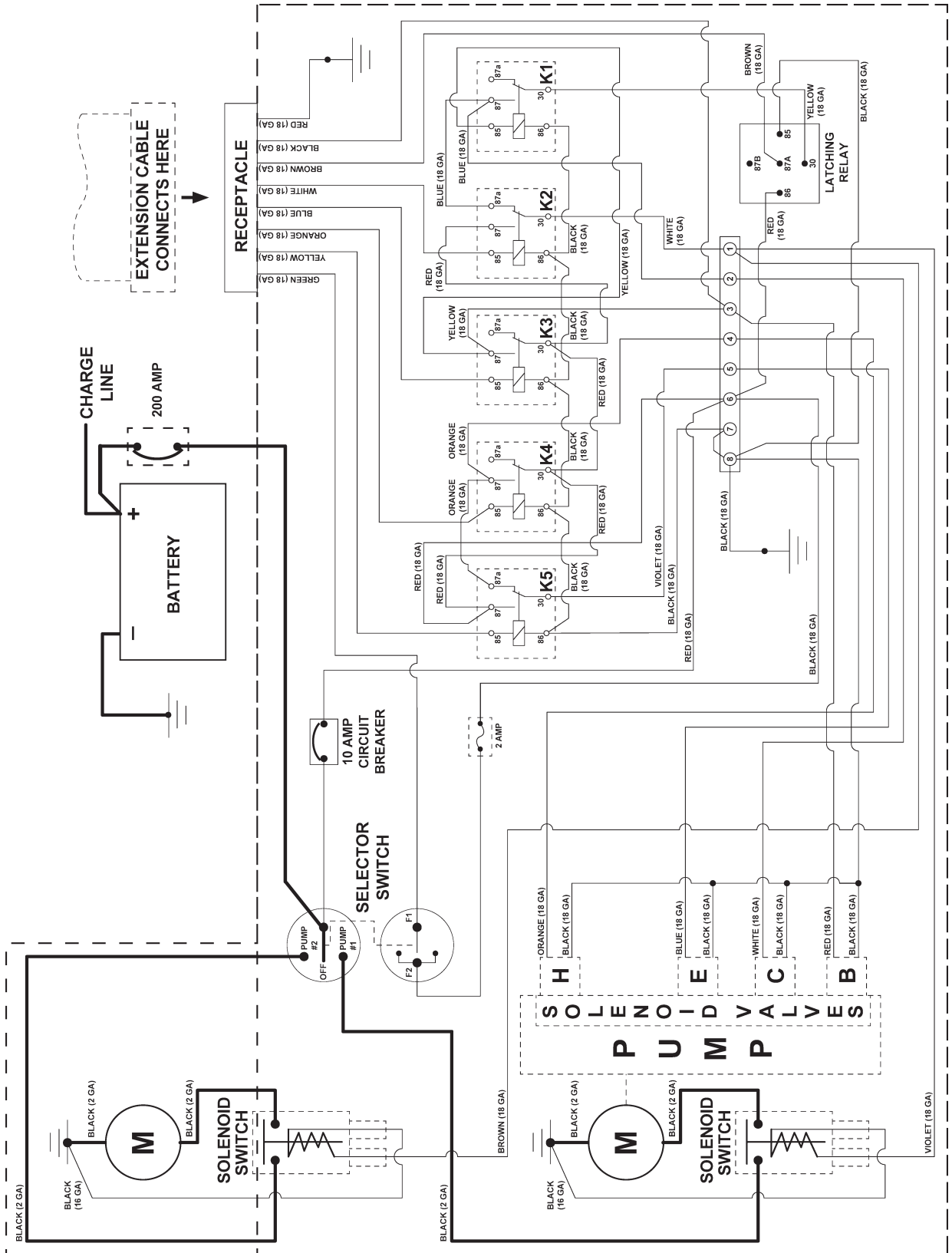

FIG. 97-1

MAXON®

PRE-DELIVERY INSPECTION FORM

Model: _____

Date: _____

Serial Number: _____

Technician: _____

Pre-Installation Inspection:

- Correct model
- Correct capacity
- Correct platform size
- Correct options
- Manuals & decals

Structural Inspection:

- Inspect alignment of final assembly
- Inspect pump box secure mounting
- Inspect all installation welds
- Check roll pins, bolts and fasteners
- Check for no twists in chain
- Inspect tightness of hardware used for securing columns to mounting plates
- Ensure platform ramp touches ground

Hydraulic Inspection:

- Proper fluid level (See OPTIMIZE HYDRAULIC FLUID LEVEL step in this manual)
- Check fittings for leaks in pump box
- Check fittings for leaks in columns

Electrical Inspection:

- Check power/charge plug and terminal
- Check for loose wires and terminals
- Circuit breaker
- Battery hookup, 12 volt
- Ensure batteries are fully charged.
- Inspect all solenoid connections
- Check all wiring harness connections
- Outside control box location
- Check electrical cable connections (at the bottom of the curb-side runner) tight and secure

Operation Inspection:

NOTE: The following times are for 56" bed height, aluminum platform and flipover 85" W x 42" + 42" L, Exxon Univis HVI-13 oil, & temperature at 70°F. Times are for reference only and may vary for larger platforms, smaller platforms, steel platforms, or temperature changes.

- Check operation of main control
- Check operation of runner control
- All BMR:** platform unfolds in 5 to 7 sec.
- All BMR:** platform folds in 5 to 7 sec.
- BMR-35 or -44 only**
- Unloaded platform lowers in **8 to 20 sec.**
- Platform loaded with 1000 lb (plus) lowers in **8 to 12 sec.**
- Unloaded platform raises in **9 to 21 sec.**
- BMR-55 or -66 only**
- Unloaded platform lowers in **12 to 23 sec.**
- Platform loaded with 1000 lb (plus) lowers in **11 to 14 sec.**
- Unloaded platform raises in **13 to 26 sec.**
- All BMR:** platform raises and lowers evenly. Maximum 1" difference from side to side.
- All BMR:** platform stores and locks securely behind both column wedges
- Check lift operation under load
- Decals in correct location and legible

11921 Slauson Ave. Santa Fe Springs, CA. 90670 (800) 227-4116 FAX (888) 771-7713

MAXON®

