



Multiple-Source Liftgate Charging System

Direct Flex™, Direct Max™, Select-21, -24, -31, -22, -25, -32

These liftgate charging systems allow charging from multiple sources. They improve the charging of liftgate batteries by utilizing a DC/DC converter to boost the voltage for optimal charging. The boost in voltage overcomes the normal voltage drop caused by the extended distance between the liftgate batteries and the vehicle charging system.

In cold temperatures, the DC/DC converter compensates for temperature by providing higher charging voltages. The result is well-charged liftgate batteries that will last longer and have ample power for liftgate operation.

For features and benefits see page 7.

Specifications:

Maximum Charge Sources	3
Designed to Meet SAE J1455	Yes
Designed to Meet SAE J560 (7-way only)	Yes

Electrical

Battery System Voltage	12 VDC
Input DC Voltage (operating)	8.0-16.0 V
Absolute Maximum Static Input DC Voltage	30 V
Nominal Charge Current	20 A
Maximum Charge Current	30 A
Quiescent Current	<5mA
Telematics Signal Output Type	Active-High
Telematics Signal Output Voltage	5V
Telematics Signal Output Impedance	50.1kΩ
Interior Light Switch Signal Type	Active-Low
Interior Light Output Type	Active-High
Maximum Interior Light Output Current	30 Amps
Low Voltage Turn Off Voltage	8 V during first 5 minutes 9 V after
Low Voltage Turn Off Time	~41 ms
Transients Protection	Yes



Environmental

Operating Temperature Range	-40° F to 185° F -40° C to 85° C
Operating Humidity	95%
Shock	Yes
Vibration	Yes
Water Intrusion (Nosebox)	IP66
Water Intrusion (Electronics)	IP67
Chemical J1455 Section 4.4	Yes

Physical

Nosebox Weight without Mounting Plate	~5 lbs
Nosebox Weight with Mounting Plate	~7.2 lbs
Housing Material	Glass Reinforced Nylon
Torque specs	Lid bolts (1/4"-20)—65 in-lbs 7-way/dual pole receptacle bolts (5/16"-18)—90 in-lbs Severe service connections (1/4"-20)—90 in-lbs Severe service cover screws (#10-32)—20 in-lbs Circuit board terminals (#10-32)—32 in-lbs Circuit board terminals (#8-32)—20 in-lbs Reefer/interior light module screws—5 in-lbs

Liftgate Charging Harness Cable Specifications:

Wire Gauge:

Orange..... 14 GA
 Yellow 16 GA
 Black.....8 GA
 White.....8 GA

Stranding:

14 GA 19/27
 16 GA 7/24
 8 GA 19/21

Overall O.D:490” O.D
 Wall:030” ± .05

Jacket Type: +80° C and -30° C Black PVC

Wire insulation: GXL

Part Numbers:

Part #	Charging Harness Length	Dual Pole receptacle	7-way receptacle	Single pole receptacle	7-way charging harness	Reefer harness	Severe Service	Shipping size	Shipping weight
9102-0005-A-A	50 FEET	X				X		16X16X8	22 LBS
9102-0009-A-A	50 FEET	X			X			16X16X8	22 LBS
9102-0013-A-A	50 FEET	X			X	X		16X16X8	26 LBS
9102-0007-A-A	50 FEET	X		X		X		16X16X8	22 LBS
9102-0011-A-A	50 FEET	X		X	X			16X16X8	24 LBS
9102-0015-A-A	50 FEET	X		X	X	X		16X16X8	26 LBS
FLEX-25-A	25 FEET	X	X					16X16X8	15 LBS
FLEX-50-A	50 FEET	X	X					16X16X8	18 LBS
FLEX-70-A	70 FEET	X	X					16X16X8	21 LBS
MAX-50-A	50 FEET	X	X				X	16X16X8	41 LBS
MAX-25-A	25 FEET	X	X				X	16X16X8	38 LBS
MAX-70-A	70 FEET	X	X				X	16X16X8	44 LBS

Note: Part numbers listed above include nosebox and harness. Kits include nosebox, harness, and DC/DC converter.

Add-ons: Direct Flex and Max

Part #	Description
NB00052	SINGLE POLE ADD-ON FOR FLEX or MAX
H-00521	INTERIOR LIGHT POWER HARNESS ADD-ON, 25 FT, FOR FLEX or MAX
H-00522	INTERIOR LIGHT POWER HARNESS ADD-ON, 50 FT, FOR FLEX or MAX
H-00523	INTERIOR LIGHT POWER HARNESS ADD-ON, 70 FT, FOR FLEX or MAX
H-00289	REEFER HARNESS ADD-ON FOR FLEX OR MAX

Interior Light Controller

Turn on/off from nosebox or from switch in trailer

Turn off after timeout (includes settings for 15, 30, 60, and 90 minutes; default is 60 minutes)

Detects when truck is started and turns off lights

Blinks lights three times three minutes before turning off, two times two minutes before turning off, and once one minute before turning off



LED Logic

LED	STATUS
Green solid	Charging
Green blink	Good voltage
Orange blink	Low voltage
Orange rapid-blink	Fault



Dimensions:

Note: All noseboxes have the same dimensions, regardless of number or type of receptacles.

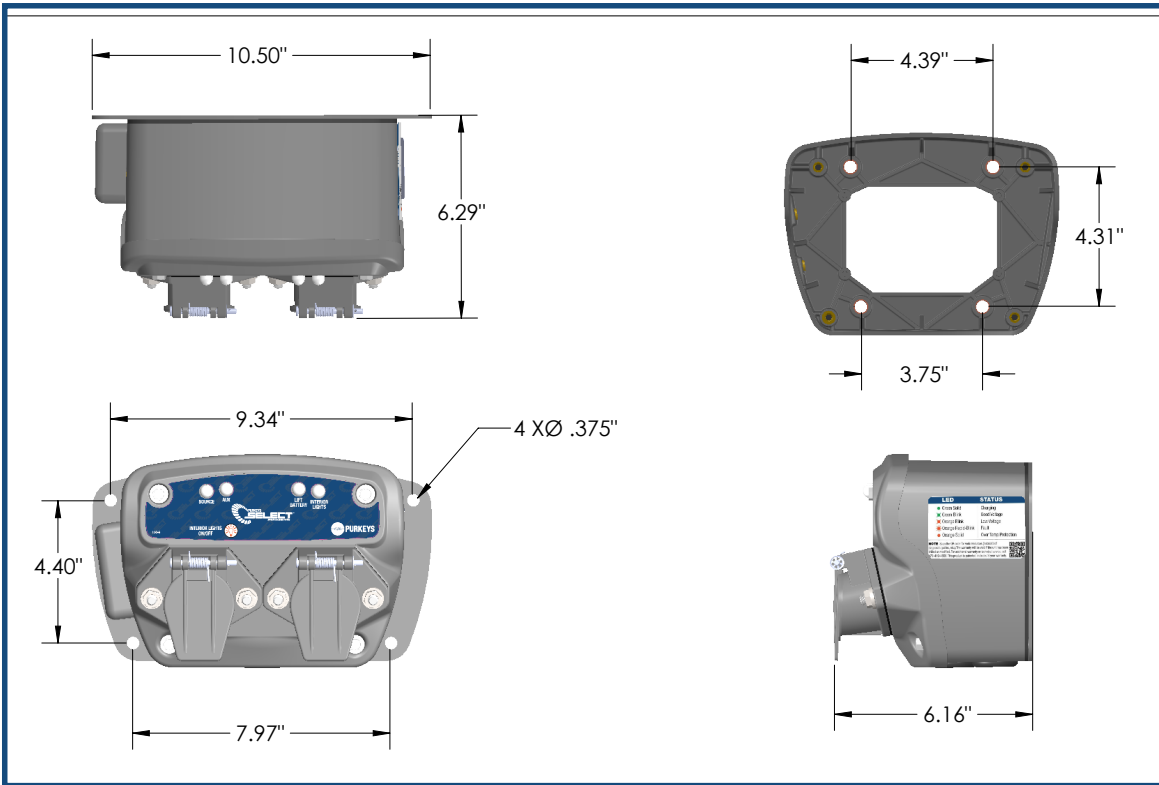

Call-Outs: Exterior, One Receptacle

Dual Pole Receptacle: Select-21, -24, -31

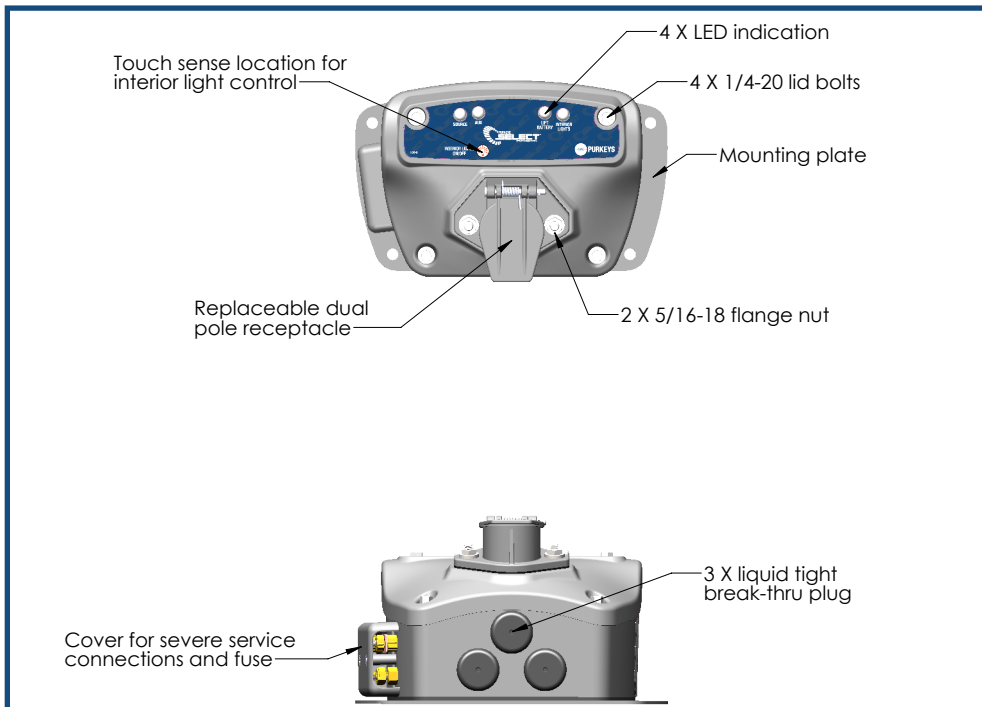

Call-Outs: Exterior, Two Receptacles

Dual Pole and Single Pole: Select-22, -25, -32

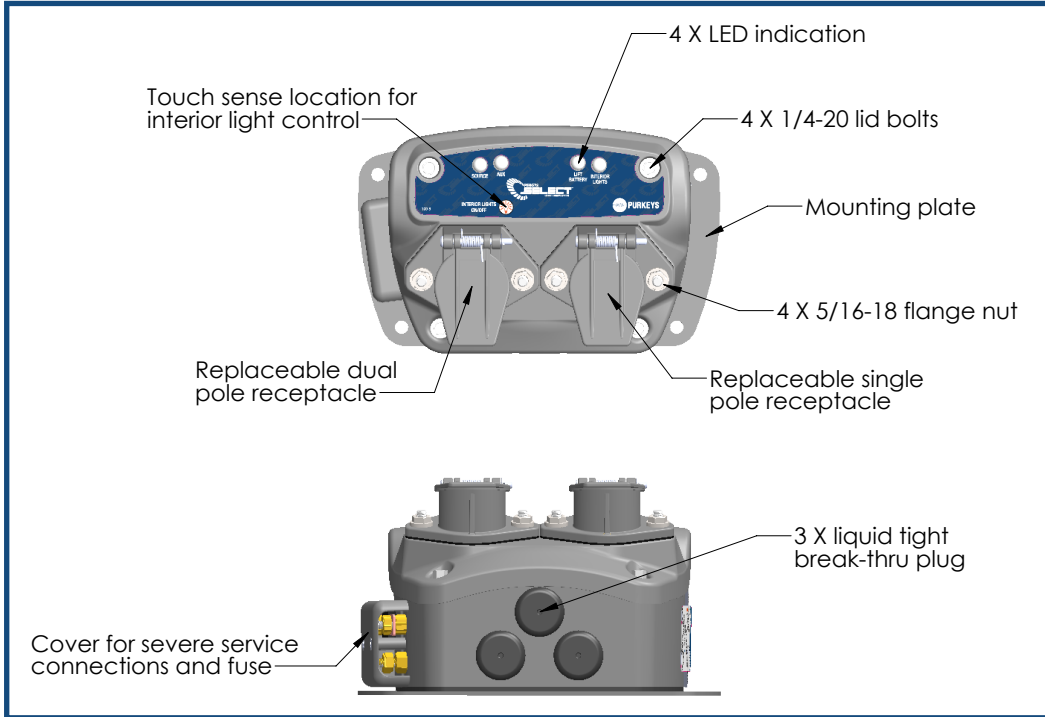

Dual Pole and 7-Way: Direct Flex and Max

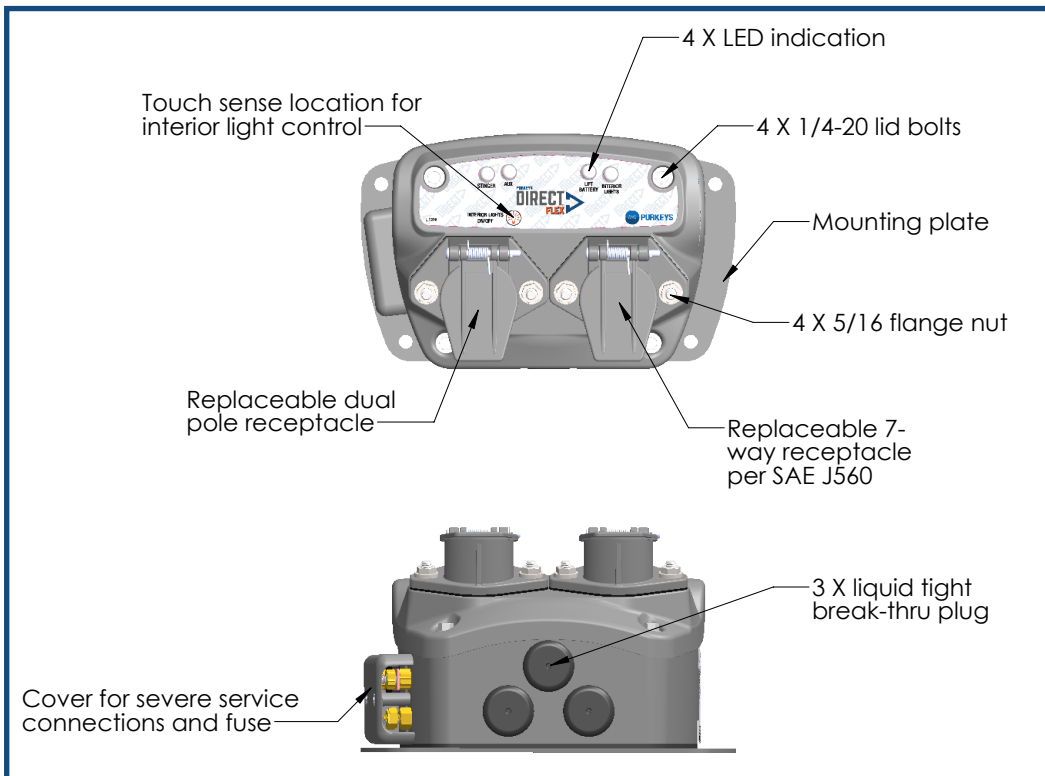

Call-Outs: Side Panels for External Connections

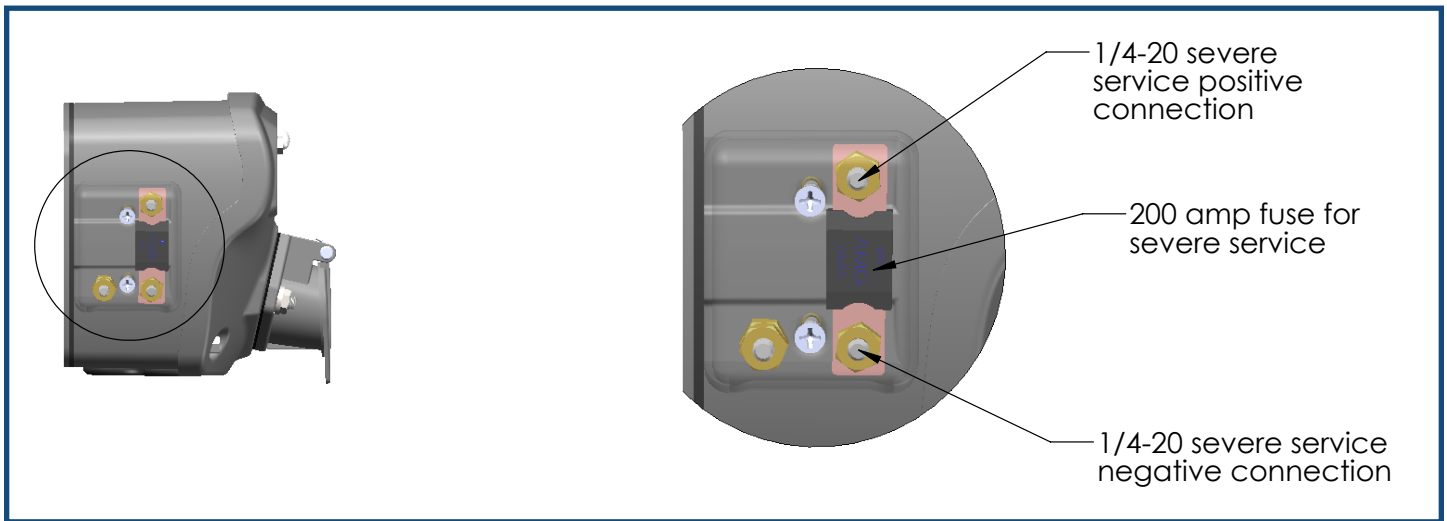

Features:

- All-in-One Enclosure.....
- Extend Function
- Nylon-66 Glass Reinforced Enclosure.....
- Multiple Charge Sources
- DC/DC Converter Based - Utilizes Voltage Drop Compensation to Provide Faster Recharge.....
- Monitors Input Power.....
- Telematics Signal
- Downward Angled Sockets.....
- Sealed Nylon Receptacles.....
- Replaceable Sockets.....
- Easy to Read LED Indication.....
- Interior Dome Light Controller.....
- Fused Dual Pole Power Studs.....
- Pre-attached Mounting Plate
- GXL Wiring.....
- Intelligent Electronic Controller
- Powers Interior Dome Lights from the Liftgate Battery (Optional Harness Required)
- Optimal Severe Service.....

Benefits:

- Saves space on the front of trailer by combining liftgate charging system into single/dual pole nosebox
- Intelligently continues to charge liftgate batteries after the truck is turned off (function varies by model)
- Durable and long lasting
- Maximizes energy transfer to liftgate batteries
- Maintains and protects batteries, maximizes battery life, and reduces downtime
- Gives priority to ABS by turning off within 1/20th of a second if the voltage drops below 9.5V
- Alerts the “back office” when liftgate batteries are critically low
- Reduce moisture on terminals so connections remain good longer
- Prevents moisture intrusion through receptacle connection
- Makes repairs easier
- Alerts drivers and technicians of system status, so they can work faster with confidence
- Allows for interior light control
- Easily connect to Severe Service cables
- Easily attach the nosebox to the trailer
- Able to withstand extreme temperatures
- Automatically chooses best charge source: aux, dual pole, or reefer (with optional reefer harness)
- Powers interior lights even when truck is off or when trailer is disconnected from truck
- Increases energy transfer to liftgate batteries

Other:

- Patented (patent #s 8,004,242 and 9,725,000; additional patents pending)
- 3-year warranty