

SLIDELIFT® SERIES

The GPSLR Series



GPSLR SPECIFICATIONS

Level ride, FMVSS & CMVSS underride certification and the industry's toughest finish create the smartest choice in sliders.

- Level-ride platform
- Aluminum flip-over sections with MAX GRIP® surface treatment
- SmartSpace (gap between platform and rear sill)
- Optimized lift arm design that allows to bridge up to 13" rear sill depth
- Hydraulic locking system
- Works for all types of trailer door configurations
- Flashing platform lights standard
- Meets underride impact certifications (CMVSS & FMVSS)
- **Galvanized Finish-STANDARD!**

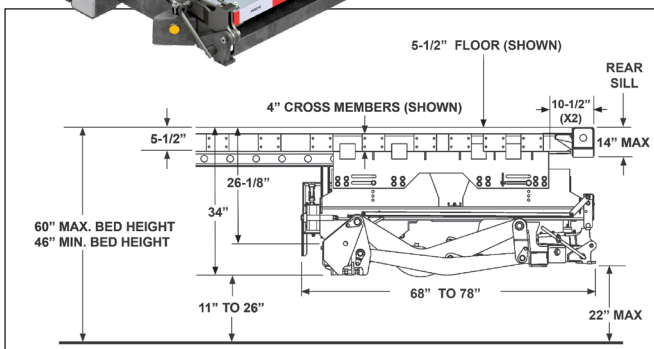

Clearances For GPSLR With 68" - 78" Slide Rails (Trailer)

NOTE: Please review appropriate liftgate installation manual for full vehicle and or body requirements to ensure proper fitment.

MODEL CAPACITY	PLATFORM SIZE	TOTAL WEIGHT	BED HEIGHT
GPSLR35 (3,500 lbs)	86" X 51"+9" Fixed Ramp Optional Dual Cart Stops	1,690 Lbs.	46" Min. with Body Laden
	86" X 60"+12" Single or Dual retention ramp		
GPSLR44 (4,400 lbs)	86" X 63"+9" Fixed Ramp Optional Dual Cart Stops	1,815 Lbs.	60" Max. with Body Unladen
	86" X 72"+12" Single or Dual retention ramp		
GPSLR55 (5,500 lbs)	86" X 80"+12" Single or Dual retention ramp	1,950 Lbs	

SLIDELIFT® SERIES

The GPSLR Series

MAXON®

Standard Features

- Galvanized Standard
- MAX GRIP® Platform Treatment
- Cycle Counter
- SmartSpace
- Level Ride Platform
- Hydraulic Locking System
- Lightweight AL Flip-Over
- FMVSS & CMVSS Compliant

Optional Features

- Dual Cart Stops
- Hand-held Control
- Power Down
- Dual Pump & Motor
- MAX ECU
- Platform Railing Kit

Loadable Platform Space with Cart Stops Deployed

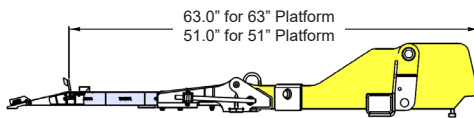

Level Ride

The GPSLR rides level all the way to the ground, similar to a rail liftgate. The platform design allows for loads to be easily loaded on and off because it sits completely flat on the ground.



Aluminum Platform, Flip-Over MAX GRIP®

The platform flip-over features dual assist torsion springs that minimize the opening and closing force. Flip-over surface is cross-hatched for improved slip resistance (MAX GRIP®)

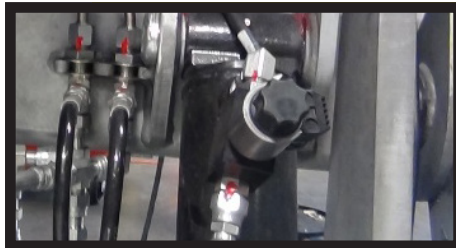

Hydraulic Locking System

The GPSLR features a hydraulic locking system that takes the operator out of the equation. The hydraulic system automatically locks when the gate is in the stow position requiring no additional operator effort.



Lift Arm Design

The GPSLR features a stress-optimized lift arm design that yields two key benefits: First, the stout and solid design provides ample support even when loaded to its rated capacity! Secondly, the design allows to bridge up to 13" rear seal depth without notching.

Distributed by:

M-282-0824



Fully Galvanized - STANDARD

Galvanization is the process by which zinc is coated over corrosive (easily rusted) metals. The process of galvanizing not only protects from corrosion of various 'soft metals' but also adds strength to the original, uncoated metal