

MAXON[®]

M-18-10
OCTOBER 2024
REV C

GPSLR/RA Series

MAINTENANCE MANUAL

GPSLR-35, GPSLR-44 & GPSLR-55
GPSLRT-35, GPSLRT-44 & GPSLRT-55
RA-35 & RA-45

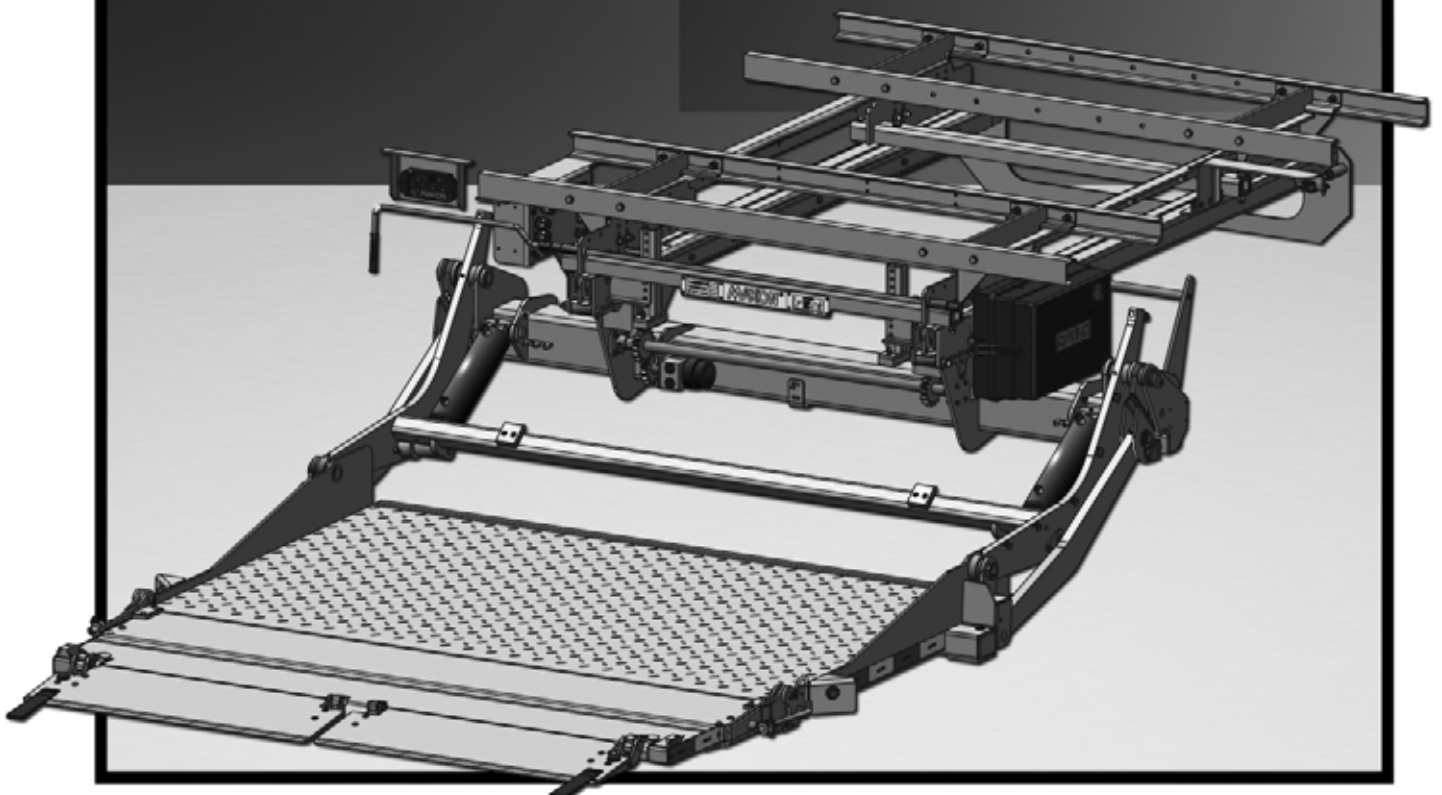
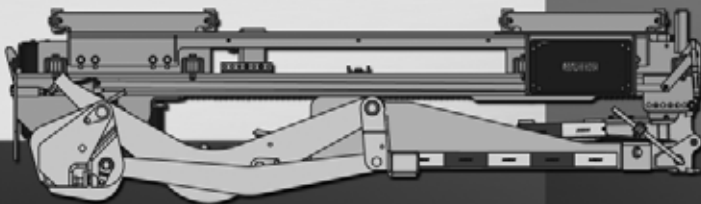

MAXON[®]

LIFT CORP.

11921 Slauson Ave.
Santa Fe Springs, CA. 90670

CUSTOMER SERVICE:

TELEPHONE (562) 464-0099 TOLL FREE (800) 227-4116

FAX: (888) 771-7713

NOTE: For latest version of all Manuals (and replacements), download the Manuals from Maxon's website at www.maxonlift.com.

WARRANTY/ RMA POLICY & PROCEDURE

LIFTGATE WARRANTY

Type of Warranty: Full Parts and Labor

Term of Warranty: Standard Liftgates - 2 years from ship date or 6,000 cycles
Premium Liftgates - 2 years from ship date or 10,000 cycles

This warranty shall not apply unless the product is installed, operated and maintained in accordance with MAXON Lift's specifications as set forth in MAXON Lift's Installation, Operation and Maintenance manuals. This warranty does not cover normal wear, maintenance or adjustments, damage or malfunction caused by improper handling, installation, abuse, misuse, negligence, or carelessness of operation. In addition, this warranty does not cover equipment that has had unauthorized modifications or alterations made to the product.

MAXON agrees to replace any components which are found to be defective during the first 2 years of service, and will reimburse for labor based on MAXON's Liftgate Warranty Flat Rate Schedule. (Copy of the Flat Rate is available at www.maxonlift.com.)

All warranty repairs must be performed by an authorized MAXON warranty facility. For any repairs that may exceed \$500, including parts and labor, MAXON's Technical Service Department must be notified and an "Authorization Number" obtained.

All claims for warranty must be received within 30 Days of the repair date, and include the following information:

1. Liftgate Model Number and Serial Number
2. The End User must be referenced on the claim
3. Detailed Description of Problem
4. Corrective Action Taken, and Date of Repair
5. Parts used for Repair, Including MAXON Part Number(s)
6. MAXON R.M.A. # and/or Authorization # if applicable (see below)
7. Person contacted at MAXON if applicable
8. Claim must show detailed information i.e. Labor rate and hours of work performed

Warranty claims can also be placed online at www.maxonlift.com. Online claims will be given priority processing.

All claims for warranty will be denied if paperwork has not been received or claim submitted via Maxon website for processing by MAXON's Warranty Department within 30 days of repair date.

All components may be subject to return for inspection, prior to the claim being processed. MAXON products may not be returned without prior written approval from MAXON's Technical Service Department. Returns must be accompanied by a copy of the original invoice or reference with original invoice number and are subject to a credit deduction to cover handling charges and any necessary reconditioning costs. **Unauthorized returns will be refused and will become the responsibility of the returnee.**

Any goods being returned to MAXON Lift must be pre-approved for return, and have the R.M.A. number written on the outside of the package in plain view, and returned freight prepaid. All returns are subject to a 15% handling charge if not accompanied by a detailed packing list. Returned parts are subject to no credit and returned back to the customer. Defective parts requested for return must be returned within 30 days of the claim date for consideration to:

MAXON Lift Corp.
10321 Greenleaf Ave., Santa Fe Springs, CA 90670
Attn: RMA# _____

MAXON's warranty policy does not include the reimbursement for travel time, towing, vehicle rental, service calls, oil, batteries or loss of income due to downtime. Fabrication or use of non Maxon parts, which are available from MAXON, are also not covered.

MAXON's Flat Rate Labor Schedule takes into consideration the time required for diagnosis of a problem.

All Liftgates returned are subject to inspection and a 15% restocking fee. Any returned Liftgates or components that have been installed or not returned in new condition will be subject to an additional reworking charge, which will be based upon the labor and material cost required to return the Liftgate or component to new condition.

PURCHASE PART WARRANTY

Term of Warranty: 1 Year from Date of Purchase.

Type of Warranty: Part replacement only. MAXON will guarantee all returned genuine MAXON replacement parts upon receipt and inspection of parts and original invoice.

All warranty replacements parts will be sent out via ground freight. If a rush shipment is requested, all freight charges will be billed to the requesting party.

TABLE OF CONTENTS

SUMMARY OF CHANGES: M-18-10, REVISION C.....	5
WARNINGS.....	6
SAFETY INSTRUCTIONS	7
LIFTGATE TERMINOLOGY- GPSLR	8
LIFTGATE TERMINOLOGY- RA	9
PERIODIC MAINTENANCE.....	10
PERIODIC MAINTENANCE CHECKS	10
PREVENTATIVE MAINTENANCE CHECKLIST	11
CHECKING HYDRAULIC FLUID	14
CHANGING HYDRAULIC FLUID	16
PLATFORM ADJUSTMENT	18
DECALS	25
SYSTEM DIAGRAMS	30
PUMP & MOTOR SOLENOID OPERATION - SINGLE PUMP	30
PUMP & MOTOR SOLENOID OPERATION - DUAL PUMPS	31
HYDRAULIC SCHEMATIC - GRAVITY DOWN.....	32
HYDRAULIC SCHEMATIC - POWER DOWN	33
ELECTRICAL SCHEMATIC, 12V, GRAVITY DOWN, WITH MAX ECU	34
ELECTRICAL SCHEMATIC, 12V, POWER DOWN, WITH MAX ECU	36
ELECTRICAL SCHEMATIC 12V/24V, GRAVITY DOWN	38
ELECTRICAL SCHEMATIC, 12V/24V, POWER DOWN	40
TROUBLESHOOTING	42

SUMMARY OF CHANGES: M-18-10, REVISION C

PAGE	DESCRIPTION OF CHANGE
COVER	Updated REV. and date. Updated
14	Updated fill level in procedure for checking hydraulic fluid.
16	Updated fill level in procedure for changing hydraulic fluid.
19	Updated adjustment instruction for tilting platform tip up and down.
21	Updated initial platform in/out adjustment to provide a gap of 1" between platform and trailer wall.
22	Updated platform adjustment instruction to cut 1" off ends of aluminum extrusion on both sides of doorway on trailers with recessed floors.
23	Updated procedure to get a 5/8" gap between platform heel and recessed edge of the floor.
35, 37, 39, 41	Updated electrical schematics to show battery power and ground cables connections on J-box. Corrected position of Limit Switch plunger for stow condition.

MAXON® 11921 Slauson Ave. Santa Fe Springs, CA. 90670 (800) 227-4116 FAX (888) 771-7713

Comply with the following **WARNINGS** and **SAFETY INSTRUCTIONS** while installing Liftgates. See Operation Manual for operating safety requirements.

⚠ WARNING

Installing and maintaining a liftgate can expose you to chemicals, including lead, which are known to the State of California to cause cancer and birth defects or other reproductive harm. To minimize exposure, install and maintain liftgate in a well-ventilated area and wear **proper Personal protective equipment (PPE)**. For more information go to www.P65Warnings.ca.gov.

⚠ WARNING

- Do not stand, or allow obstructions, under the platform when lowering the Liftgate. **Be sure your feet are clear of the Liftgate.**
- **Keep fingers, hands, arms, legs, and feet clear of moving Liftgate parts (and platform edges) when operating the Liftgate.**
- **Correctly stow platform when not in use. Extended platforms could create a hazard for people and vehicles passing by.**
- **Disconnect Liftgate power cable from battery** before repairing or servicing Liftgate.
- **Remove all rings, watches and jewelry before doing any electrical work.**
- If it is necessary to stand on the platform while maintaining the Liftgate, keep your feet and any objects clear of the inboard edge of the platform. Your feet or objects on the platform can become trapped between the platform and the Liftgate extension plate.
- Recommended practices for welding on steel parts are contained in the current **AWS (American Welding Society) D1.1 Structural Welding Code - Steel**. Damage to Liftgate and/or vehicle, and personal injury could result from welds that are done incorrectly.
- Recommended practices for welding on aluminum parts are contained in the current **AWS (American Welding Society) D1.2 Structural Welding Code - Aluminum**. Damage to Liftgate and/or vehicle, and personal injury could result from welds that are done incorrectly.
- Recommended practices for welding galvanized steel are contained in the current **AWS (American Welding Society) D19.0 Welding Zinc-Coated Steel**. Damage to Liftgate and/or vehicle, and personal injury can result from welds that are done incorrectly.

MAXON[®]

11921 Slauson Ave. Santa Fe Springs, CA. 90670 (800) 227-4116 FAX (888) 771-7713

SAFETY INSTRUCTIONS

- Read and understand the instructions in this **Maintenance Manual** before performing maintenance on the Liftgate.
- Before operating the Liftgate, read and understand the operating instructions in **Operation Manual**.
- Comply with all **WARNING** and instruction decals attached to the Liftgate.
- Keep decals clean and legible. If decals are illegible or missing, replace them. Free replacement decals are available from **Maxon Customer Service**.
- Consider the safety and location of bystanders and location of nearby objects when operating the Liftgate. Stand to one side of the platform while operating the Liftgate
- Do not allow untrained persons or children to operate the Liftgate.
- Wear appropriate safety equipment such as protective eyeglasses, faceshield and clothing while performing maintenance on the Liftgate and handling the battery. Debris from drilling and contact with battery acid may injure unprotected eyes and skin.
- Be careful working by an automotive type battery. Make sure the work area is well ventilated and there are no flames or sparks near the battery. Never lay objects on the battery that can short the terminals together. If battery acid gets in your eyes, immediately seek first aid. If acid gets on your skin, immediately wash it off with soap and water.
- If an emergency situation arises (vehicle or Liftgate) while operating the Liftgate, release the control switch to stop the Liftgate.
- A correctly installed Liftgate operates smoothly and reasonably quiet. The only noticeable noise during operation comes from the power unit while the platform is raised. Listen for scraping, grating and binding noises and correct the problem before continuing to operate Liftgate.
- Use only **Maxon Authorized Parts** for replacement parts. Provide Liftgate model and serial number information with your parts order. Order replacement parts from:

MAXON LIFT CORP. Customer Service
11921 Slauson Ave., Santa Fe Springs, CA 90670

Online: www.maxonlift.com

Express Parts Ordering: Phone (800) 227-4116 ext. 4345

Email: Ask your Customer Service representative

LIFTGATE TERMINOLOGY- GPSLR

MAXON[®]

11921 Slauson Ave. Santa Fe Springs, CA. 90670 (800) 227-4116 FAX (888) 771-7713

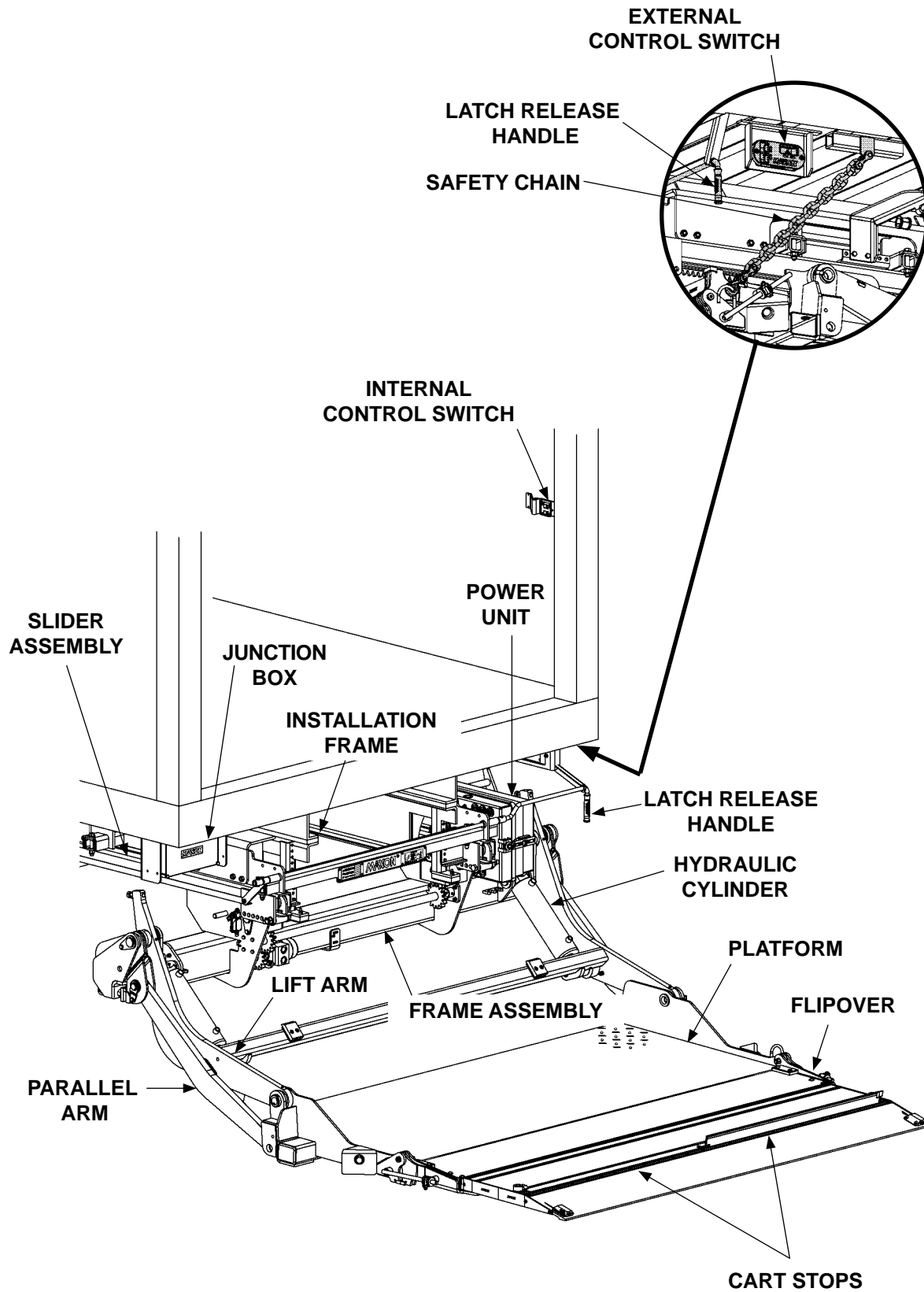

LIFTGATE TERMINOLOGY- RA

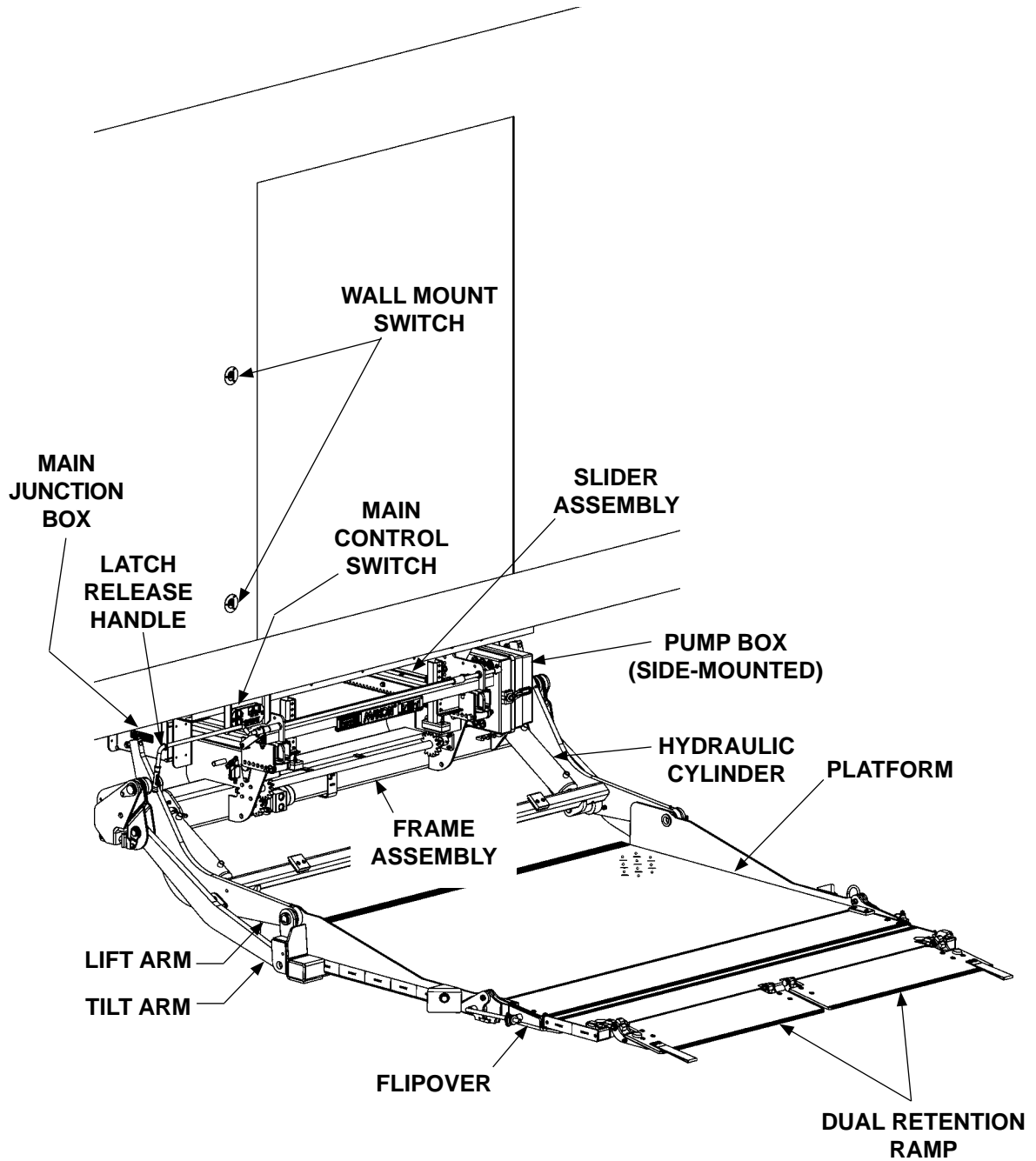

PERIODIC MAINTENANCE PERIODIC MAINTENANCE CHECKS

⚠ WARNING

Never operate the Liftgate if parts are loose or missing.

NOTE: Make sure vehicle is parked on level ground while performing the maintenance checks.

Quarterly or 1250 Cycles (whichever occurs first)

Check the hydraulic fluid level in the pump reservoir. Refer to the **CHECKING HYDRAULIC FLUID** procedure in the **PERIODIC MAINTENANCE** section. Keep track of the grade of hydraulic fluid in the pump reservoir and never mix two different grades of fluid.

If hydraulic fluid appears contaminated, refer to the **CHANGING HYDRAULIC FLUID** procedure in the **PERIODIC MAINTENANCE** section.

Check all hoses and fittings for chafing and fluid leaks. Tighten loose fittings or replace parts as required.

Check electrical wiring for chafing and make sure wiring connections are tight and free of corrosion.

Check that all **WARNING and instruction decals** are in place. Also, make sure decals are legible, clean and undamaged.

Check that all bolts, nuts, and roll pins are in place. Make sure roll pins protrude evenly from both sides of hinge pin collar. Replace fasteners and roll pins if necessary.

Check for debris and dirt buildup on the slider rollers and rails. Clean out any buildup of dirt and debris.

CAUTION

Damaged cylinder seals and contaminated hydraulic fluid can result from painting the polished portion of the cylinder rod. To prevent damage, protect the exposed polished portion of the cylinder rod while painting.

Check for rust and oily surfaces on Liftgate. If there is rust or oil on Liftgate, clean it off. Touch up the paint, where bare metal is showing, with aluminum primer touchup paint.

Pump EP chassis grease in each lube fitting on the cylinders and arms until grease starts oozing from ends of the bearings. The lubrication diagram on the **PERIODIC MAINTENANCE CHECKLIST SHEET** shows where to find the lube fittings. Wipe off excess grease with a clean lint-free cloth.

Check that safety chain and snap hook are in place.

Semi-annually or 2500 Cycles (whichever occurs first)

Visually check the platform hinge pins for excessive wear and broken welds. See **PARTS BREAKDOWN** section for replacement parts. Also, do the **Quarterly or 1250 Cycles** maintenance checks.

Annually or 5000 Cycles (whichever occurs first)

Change the hydraulic fluid.

PERIODIC MAINTENANCE MAXON GPSLR/RA LIFTGATE PREVENTATIVE MAINTENANCE CHECKLIST

PM Interval: Quarterly / Annual

Date: ___ / ___ / ___

Equipment: _____

W/O # _____

Location: _____

Mechanic: _____

Serial # _____

Model # _____

Check Appropriate Box. "☐"

MAXON Quarterly / 1250 Cycles Liftgate PM Procedures				
Satisfactory	Repair Required	Corrected	1	Check your company's maintenance records to verify when quarterly and annual PM's are due.
Satisfactory	Repair Required	Corrected	2	Check for oil leaks: cylinders, fittings, hoses, valves, and fittings inside of pump box.
Satisfactory	Repair Required	Corrected	3	Check for damage: bent ramps, platform, flipover & hydraulic tubes.
Satisfactory	Repair Required	Corrected	4	Check for loose or missing nuts, bolts, covers, roll pins, screws and pins.
Satisfactory	Repair Required	Corrected	5	Check for cracked welds: platform, pump box and mounting frame.
Satisfactory	Repair Required	Corrected	6	Check platform lowering speed: Range is 7-11 seconds GPSLR/RA-35/-45 or 14 seconds GPSLR-55 with unloaded platform. Check motor (PD only) "S1" and "S2" valves for proper operation.
Satisfactory	Repair Required	Corrected	7	Check platform pins and couplers. Check roller assemblies.
Satisfactory	Repair Required	Corrected	8	Check platform raising speed: Range is 9-14 seconds GPSLR/RA-35/-45 or 14 seconds GPSLR-55 with unloaded platform.
Satisfactory	Repair Required	Corrected	9	Check open and close speed: Range is 6-12 seconds in either direction.
Satisfactory	Repair Required	Corrected	10	Check platform pins and couplers.
Satisfactory	Repair Required	Corrected	11	Check switches, circuit breaker & wiring connections on Liftgate as well as inside pump box. Also check that ground strap connections are tight.
Satisfactory	Repair Required	Corrected	12	Check gear pump for unusual noise (i.e. squealing or excessive RPM).
Satisfactory	Repair Required	Corrected	13	Check oil level with platform stowed. Refer to oil decal on pump reservoir. Check oil for contamination. Change if needed.
Satisfactory	Repair Required	Corrected	14	Check batteries: load test, corrosion, cables, hold downs and water level.
Satisfactory	Repair Required	Corrected	15	Check operation of cart stops and retention ramps (if equipped).
Satisfactory	Repair Required	Corrected	16	Check all charging and ground cable connections.
Satisfactory	Repair Required	Corrected	17	Pump EP synthetic grease in each lube fitting on the cylinders and arms. Wipe away grease seepage.
Satisfactory	Repair Required	Corrected	18	Follow your company's guidelines for completing PM stickers and maintenance records for the Liftgate.
Satisfactory	Repair Required	Corrected	19	Switch operation from pump 1 to pump 2, and from pump 2 to pump 1 (if equipped).
MAXON Annual / 5000 Cycles Liftgate PM Procedures				
Satisfactory	Repair Required	Corrected	20	Change hydraulic fluid.

For more detailed information, please refer to the applicable sections in this Maintenance Manual and the separate Parts Portal. Use only genuine Maxon replacement parts for all repairs.

PERIODIC MAINTENANCE CHECKLIST

NOTE: Lube fittings are shown for the LH cylinder, lift arm, and parallel arm.
There are also lube fittings at the same places on the RH cylinder, lift arm, and parallel arm.

Refer to lubrication diagram (**FIG. 12-1**) to find the lube fittings on gear drives, cylinders and arms. Pump EP chassis grease in each lube fitting on the gear drives, cylinders and arms until grease starts oozing from ends of the bearings. Then, wipe off excess grease with a clean lint-free cloth.

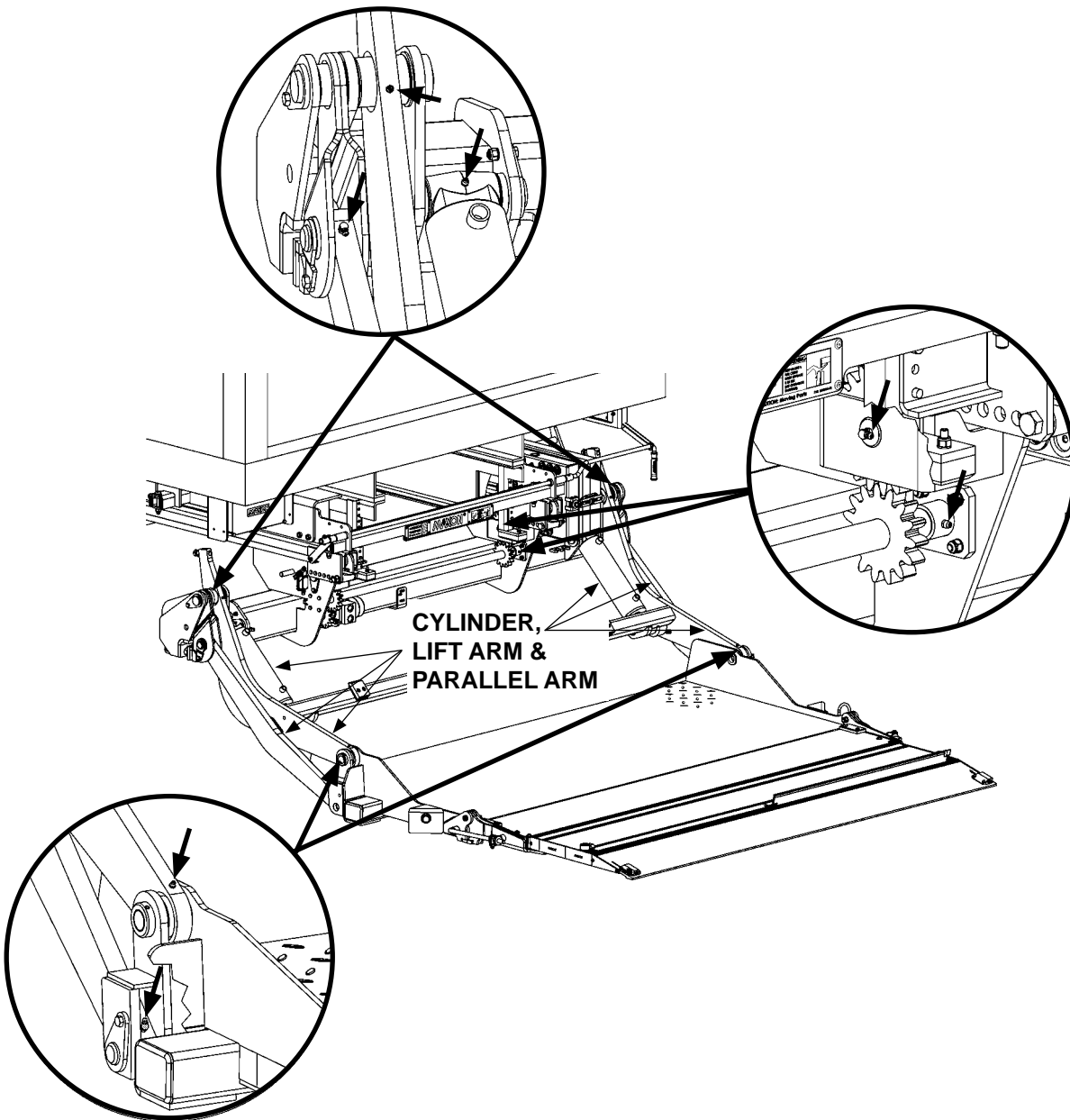

**GPSLR/RA LUBRICATION DIAGRAM (GPSLR SHOWN)
FIG. 12-1**

MAXON[®]

11921 Slauson Ave. Santa Fe Springs, CA. 90670 (800) 227-4116 FAX (888) 771-7713

THIS PAGE INTENTIONALLY LEFT BLANK

CHECKING HYDRAULIC FLUID

CAUTION

Keep dirt, water and other contaminants from entering the hydraulic system. Before opening the hydraulic fluid reservoir filler cap, drain plug and hydraulic lines, clean up contaminants that can get in the openings. Also, protect the openings from accidental contamination.

NOTE: Use correct grade of hydraulic fluid for your location.
+50 to +120 Degrees F - Grade ISO 32
Below +70 Degrees F - Grade ISO 15 or MIL-H-5606
See **TABLES 15-1 & 15-2** for recommended brands.

1. Unstow and lower platform to ground.
2. Unlatch and remove pump cover (**FIG. 14-1**).

NOTE: If the hydraulic fluid in the reservoir is contaminated, do the **CHANGING HYDRAULIC FLUID** procedure in this section.

3. Check the hydraulic fluid level in reservoir as follows. With Liftgate on ground, level should be as shown in **FIG. 14-2**.

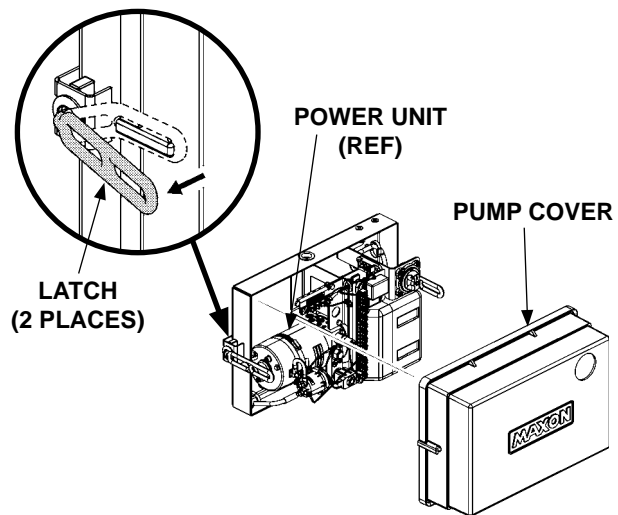

REMOVE PUMP COVER
FIG. 14-1

CAUTION

Do not fill reservoir to the **FULL** mark on the dipstick. Hydraulic fluid can overflow from the reservoir.

4. If needed, add hydraulic fluid to the reservoir as follows. Remove filler cap (**FIG. 14-2**). Fill the reservoir with hydraulic fluid to range shown on decal or to 3-3/8" from bottom of reservoir (**FIG. 14-2**). Reinstall filler cap (**FIG. 14-2**).

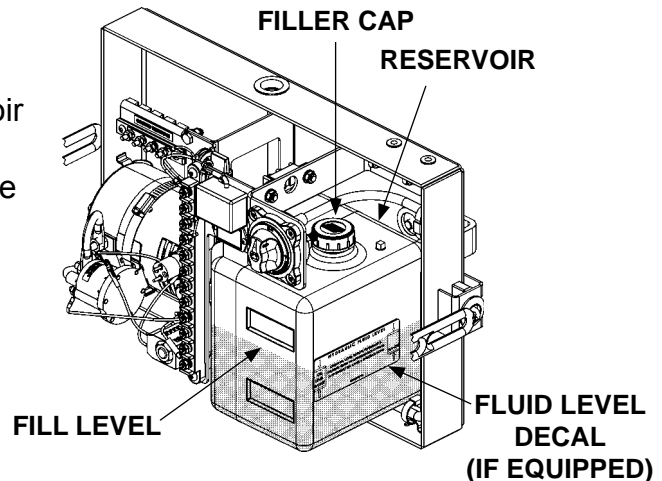

POWER UNIT HYDRAULIC
FLUID LEVEL
FIG. 14-2

CAUTION

Pump cover must be correctly secured to prevent it from becoming a hazard. Ensure pump cover is secured to pump box.

5. Reinstall and latch the pump cover as shown in **FIG. 15-1**.

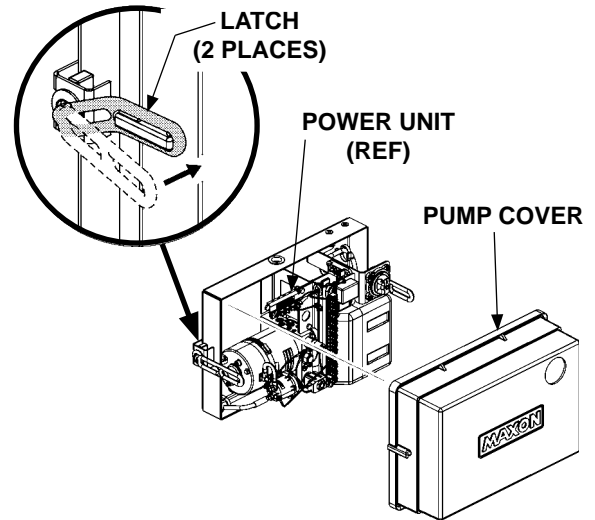

**REINSTALL PUMP COVER
FIG. 15-1**

ISO 32 HYDRAULIC FLUID	
RECOMMENDED BRANDS	PART NUMBER
ROSEMEAD	MV150
CHEVRON	AV MV32
U.S. PRESTIGE	AW HVI 32
EXXONMOBIL	DTE 10 EXCEL 32

TABLE 15-1

ISO 15 HYDRAULIC FLUID	
RECOMMENDED BRANDS	PART NUMBER
EXXONMOBIL	UNIVIS HVI-13
PHILLIPS 66	ARCTIC LOW POUR

TABLE 15-2

CHANGING HYDRAULIC FLUID

CAUTION

Keep dirt, water and other contaminants from entering the hydraulic system. Before opening the hydraulic fluid reservoir filler cap, drain plug and hydraulic lines, clean up contaminants that can get in the openings. Also, protect the openings from accidental contamination.

NOTE: Use correct grade of hydraulic fluid for your location.

+50 to +120 Degrees F - Grade ISO 32

Below +70 Degrees F - Grade ISO 15 or MIL-H-5606

See **TABLES 15-1 & 15-2** for recommended brands.

1. Unstow and lower platform to ground.

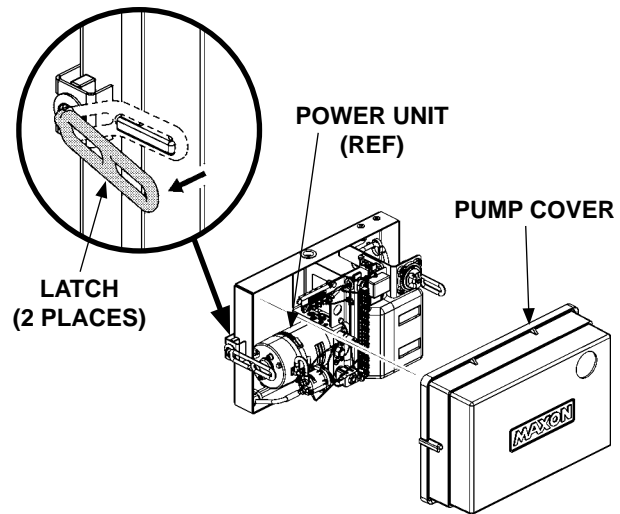

2. Unlatch and remove pump cover (FIG. 16-1).

**REMOVE PUMP COVER
FIG. 16-1**

3. Place empty 5 gallon bucket under drain plug (FIG. 16-2). Remove drain plug (FIG. 16-2). Drain hydraulic fluid. Re-install drain plug (FIG. 16-2).

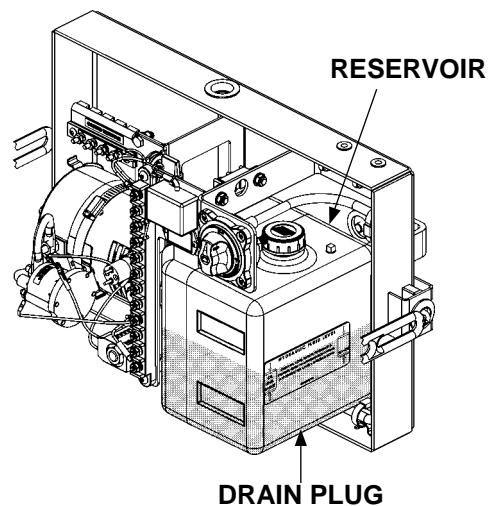

**DRAIN RESERVOIR
FIG. 16-2**

4. Remove filler cap (FIG. 17-1). Fill the reservoir with hydraulic fluid to fill level range or 3-3/8" from bottom of reservoir (FIG. 17-1). Reinstall filler cap (FIG. 17-1).
5. Run the Liftgate through 3 complete cycles. Lower platform to ground. Confirm hydraulic fluid is in fill level range.

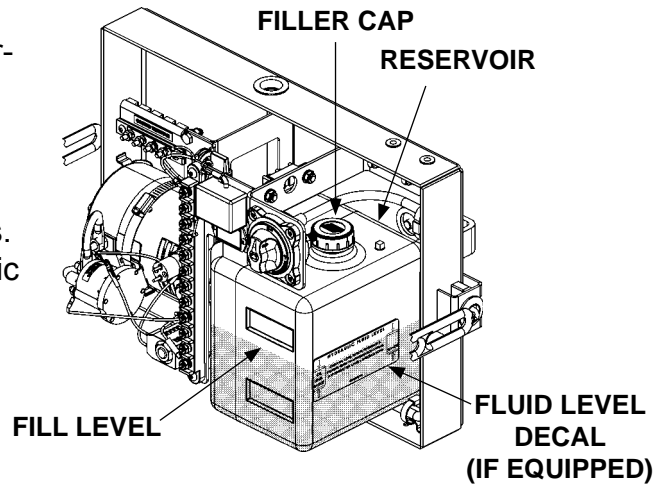

FILL PUMP RESERVOIR
FIG. 17-1

CAUTION

Pump cover must be correctly secured to prevent it from becoming a hazard. Ensure pump cover is latched to pump box.

6. Reinstall and latch the pump cover as shown in FIG. 17-2.

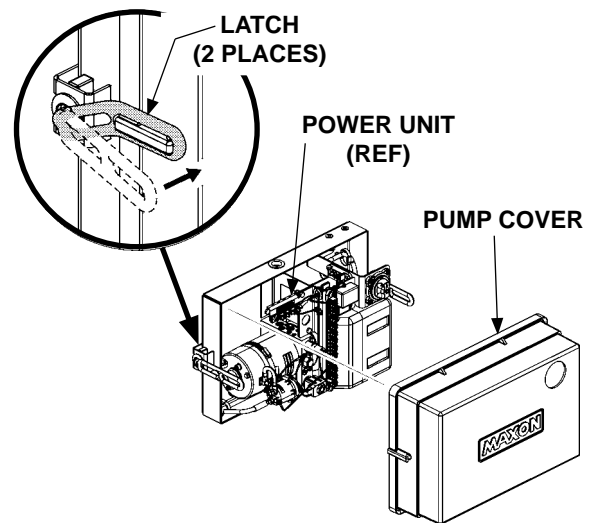

REINSTALLING PUMP COVER
FIG. 17-2

PLATFORM ADJUSTMENT

CAUTION

Operate Liftgate with caution and no load until installation is complete.

NOTE: Refer to **Operating Instructions** decal and applicable **WARNING & CAUTION** decals.

1. Move the platform out (**FIG. 18-1**) until slider mounting plate bolts hit the stop rollers (**FIG. 18-1A**).

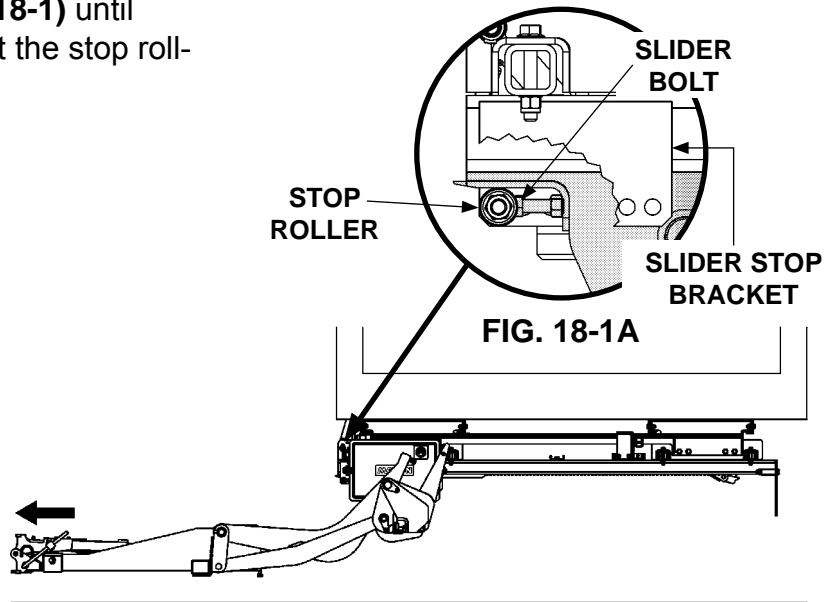

LIFTGATE TRAVELS TO OUTBOARD STOPS
FIG. 18-1

2. Lower platform to 6" above ground level and unfold flipover (**FIG. 18-2**).

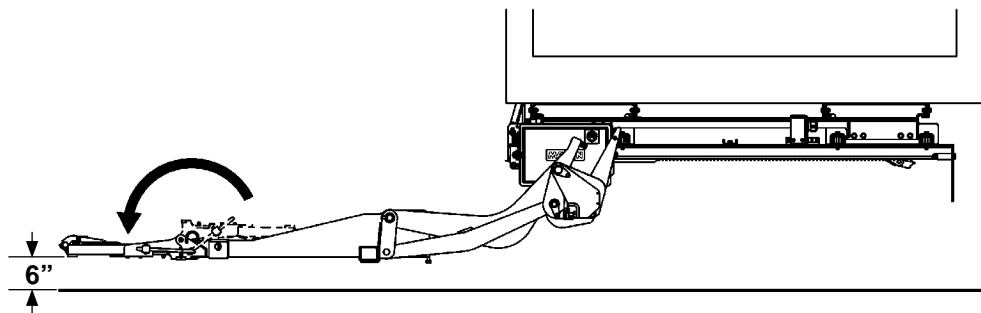

UNFOLD FLIPOVER
FIG. 18-2

MAXON[®]

11921 Slauson Ave. Santa Fe Springs, CA. 90670 (800) 227-4116 FAX (888) 771-7713

3. Lower platform to ground level (**FIG. 19-1**). Ensure platform tip and shackle touch ground.

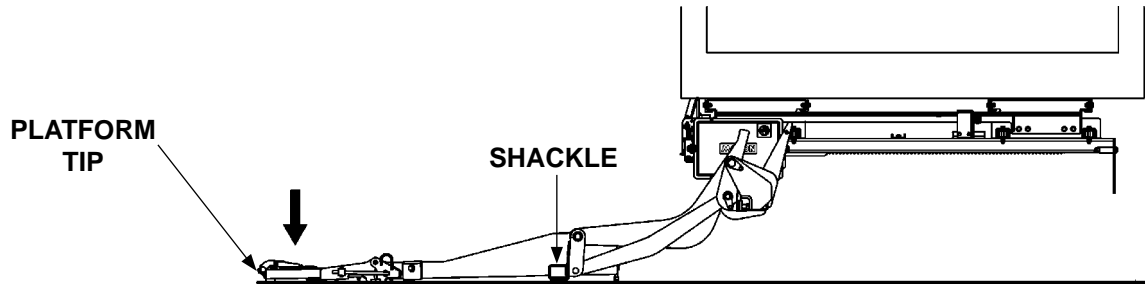

PLATFORM LOWERED TO GROUND
FIG. 19-1

4. If platform tip and shackle aren't touching the ground, loosen locking nuts on both sides of Lift-gate (**FIGS. 19-2 and 19-2A**). Turn the adjusting bolts until the shackle and platform tip touch the ground (**FIGS. 19-2 and 19-2A**). Turning adjusting bolts clockwise tilts the platform down. Turning adjusting bolts counter-clockwise tilts the platform up. Tighten locking nuts to **80 lb-ft**.

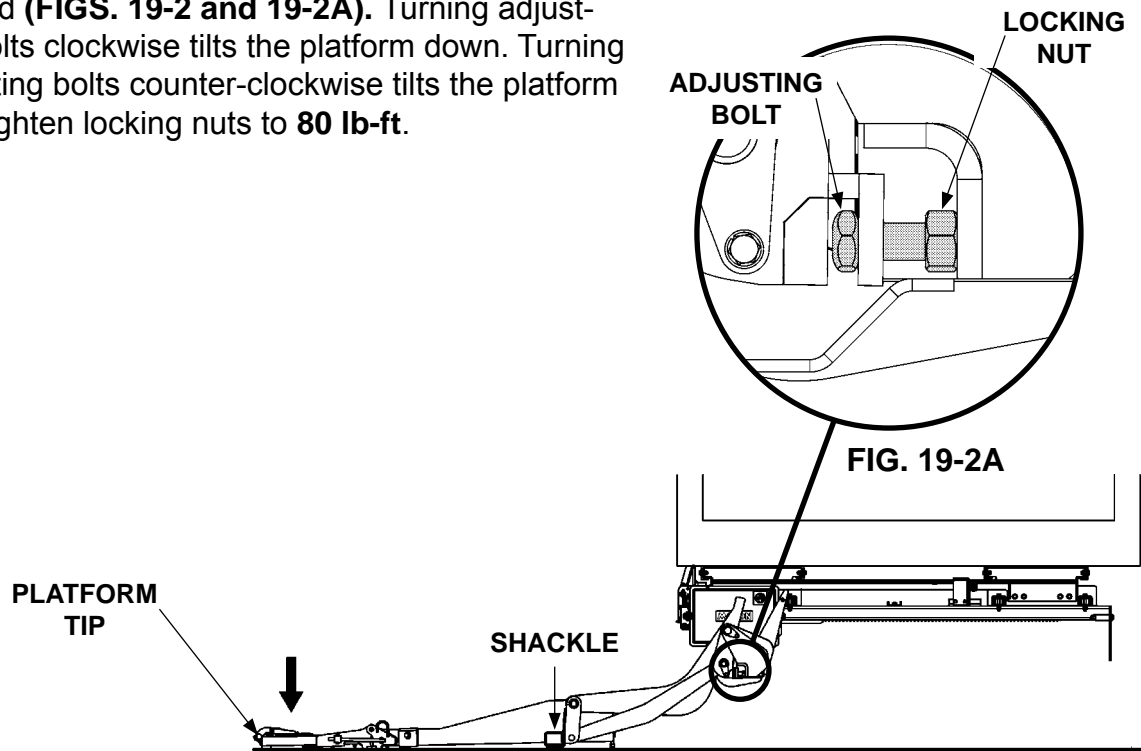

ADJUSTING PLATFORM TIP
FIG. 19-2

PLATFORM ADJUSTMENT- Continued

5. Loosen lock nut (both sides) (**FIG. 20-1**). Raise platform to trailer floor height and level it with trailer floor (**FIG. 20-1**) using adjustment bolts on lift arms (both sides) to raise or lower platform (**FIG. 20-1A**). Tighten lock nuts to **80 lb-ft**.

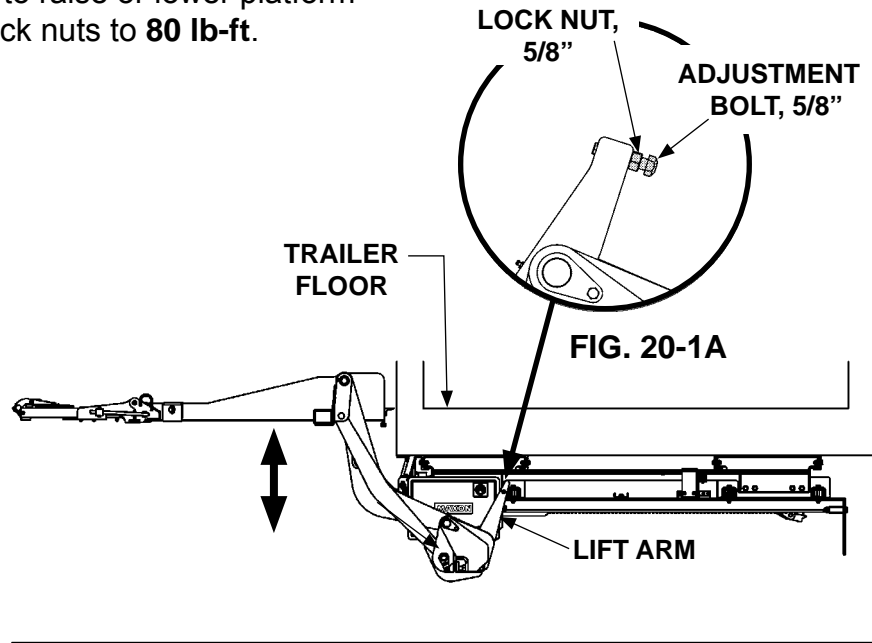

ADJUSTING PLATFORM TO FLOOR LEVEL
FIG. 20-1

MAXON[®]

11921 Slauson Ave. Santa Fe Springs, CA. 90670 (800) 227-4116 FAX (888) 771-7713

CAUTION

To prevent stop roller from binding, Do not overtighten hex bolts on stop roller. Allow 1/16" gap on each side of stop roller.

- For initial platform in/out adjustment, slide the platform in, using the control switch, to a gap of 1" between platform and trailer side wall. If the gap is greater than 1", remove stop roller from initial hole in slider stop bracket (FIGS. 21-1 and 21-1A). Reinstall the stop roller in the hole closest to the slider bolt (FIGS. 21-1, 21-1A and 21-1B). Tighten hex screw to allow 1/16" gap on each side of stop roller.

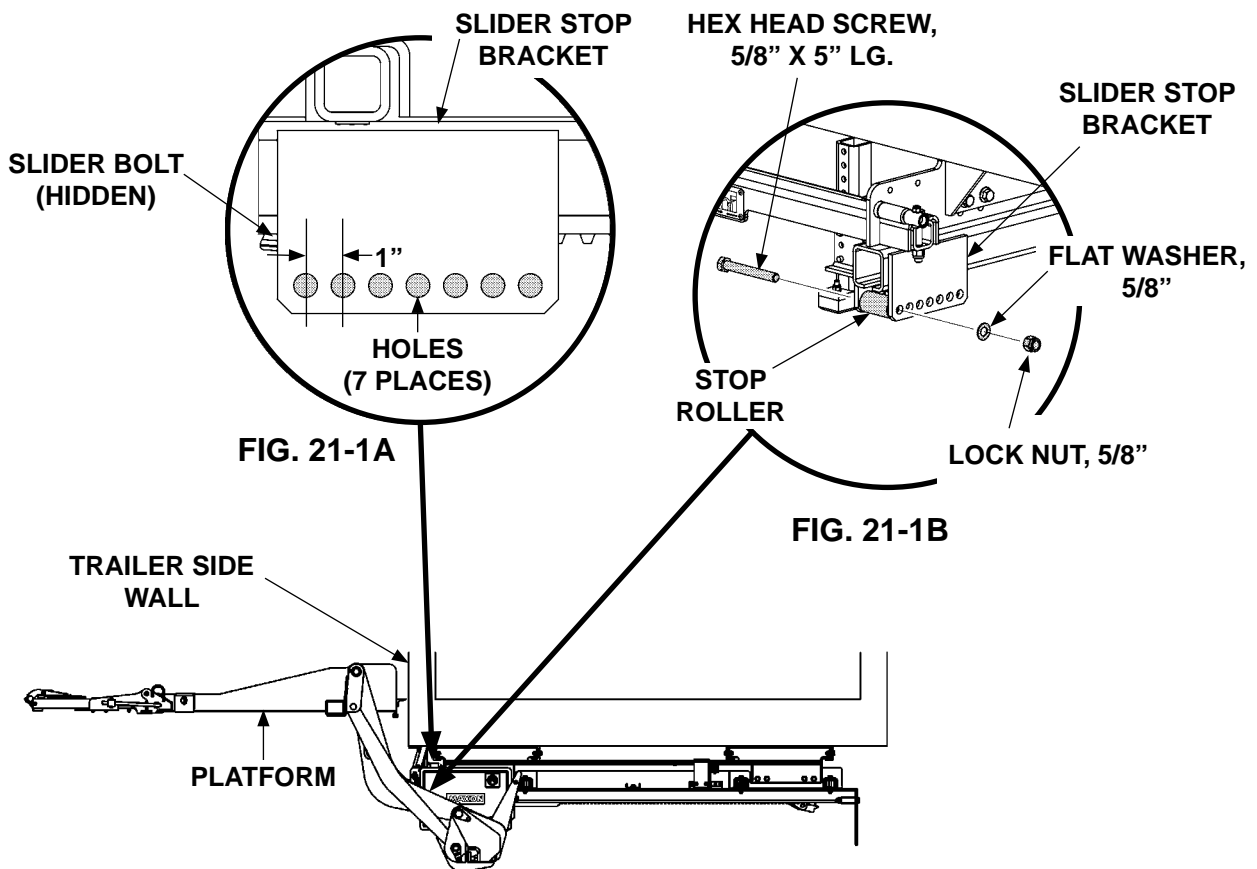

PLATFORM INITIAL IN/OUT ADJUSTMENT
FIG. 21-1

PLATFORM ADJUSTMENT- Continued

NOTE: Instruction 7 applies to RA only!

7. If the edge of the trailer floor is recessed, mark the platform end aluminum extrusion and cut 1" off on both sides of doorway (**FIGS. 22-1 and 22-1A**)

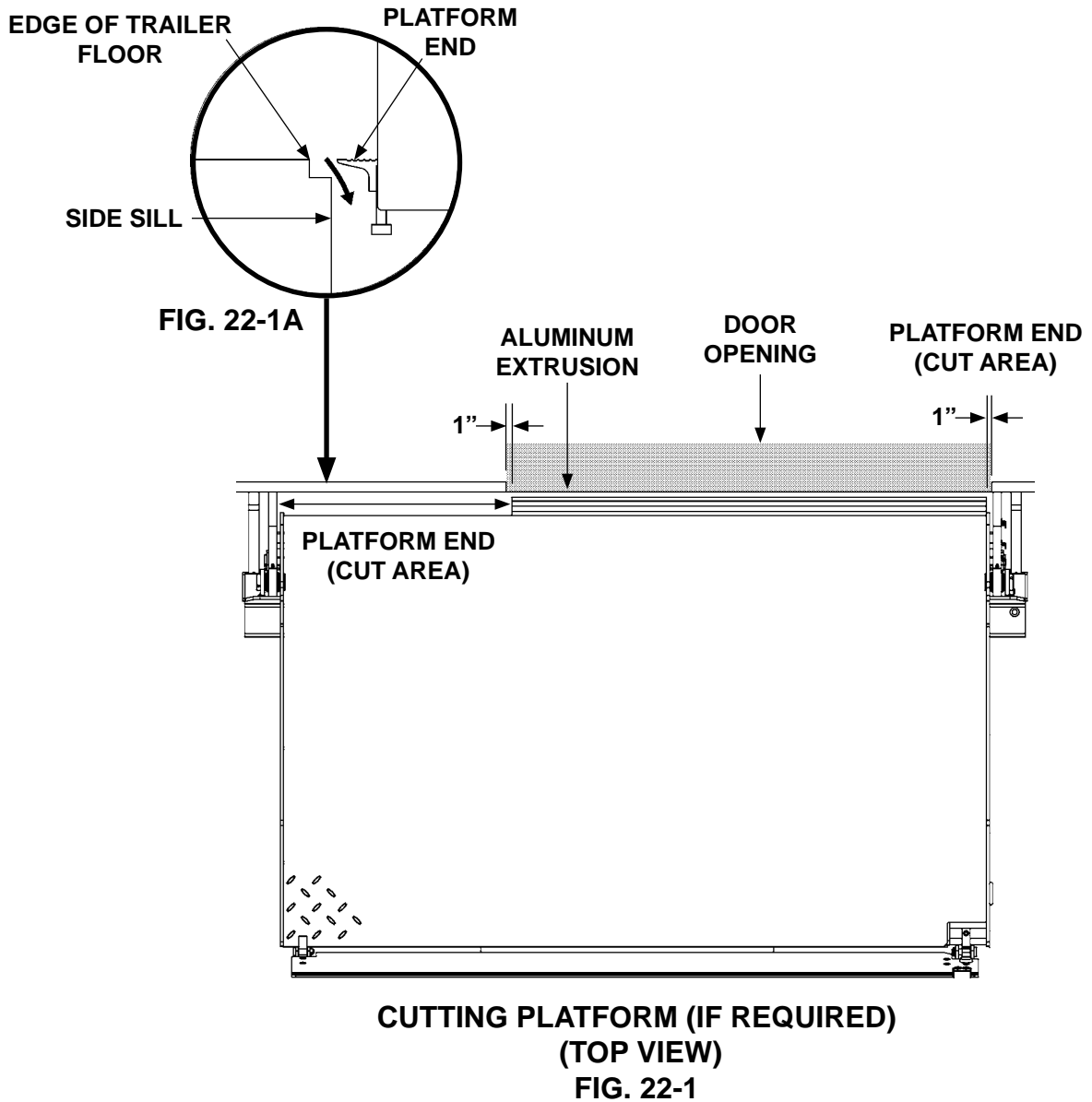

MAXON[®]

11921 Slauson Ave. Santa Fe Springs, CA. 90670 (800) 227-4116 FAX (888) 771-7713

8. Ensure platform is flush with trailer floor. If platform gap is 1" or less (**FIG. 23-1**), use adjustment bolts, located at stop rollers, to adjust platform end to approximately 5/8" gap from recessed edge of the floor (**FIGS. 23-1 and 23-1A**). Tighten each bolt to **80 lb-ft**.

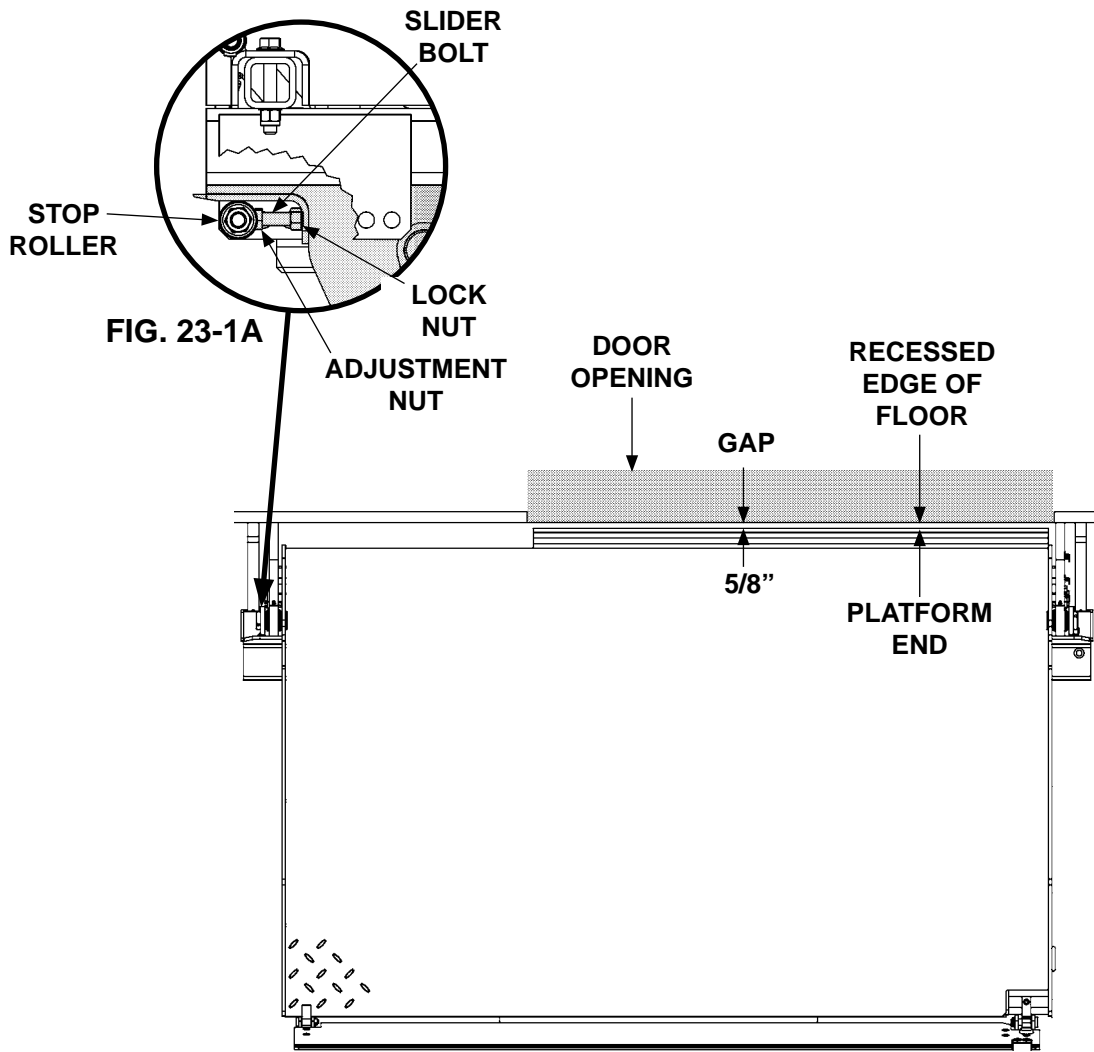

**PLATFORM FINAL IN/OUT ADJUSTMENT
(TOP VIEW)
FIG. 23-1**

PLATFORM ADJUSTMENT- Continued

CAUTION

Operate Liftgate with caution and no load until installation is complete.

NOTE: Refer to **Operating Instructions** decal and applicable **WARNING & CAUTION** decals.

9. Operate the Liftgate to ensure correct operation without binding or hitting side sill.

MAXON[®]

11921 Slauson Ave. Santa Fe Springs, CA. 90670 (800) 227-4116 FAX (888) 771-7713

DECALS

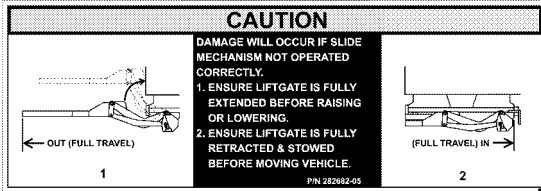

**CAUTION DECAL
P/N 282682-05**

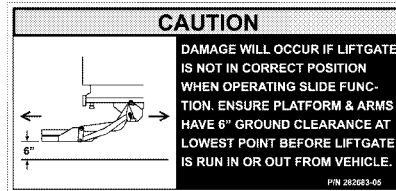

**CAUTION DECAL
P/N 282683-05**

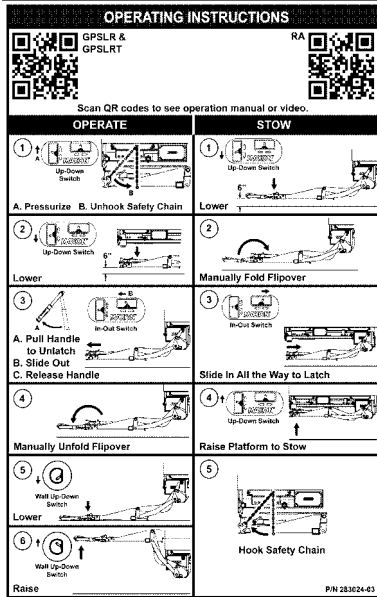

**OPERATION DECAL
P/N 283024-03**

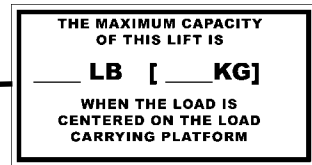
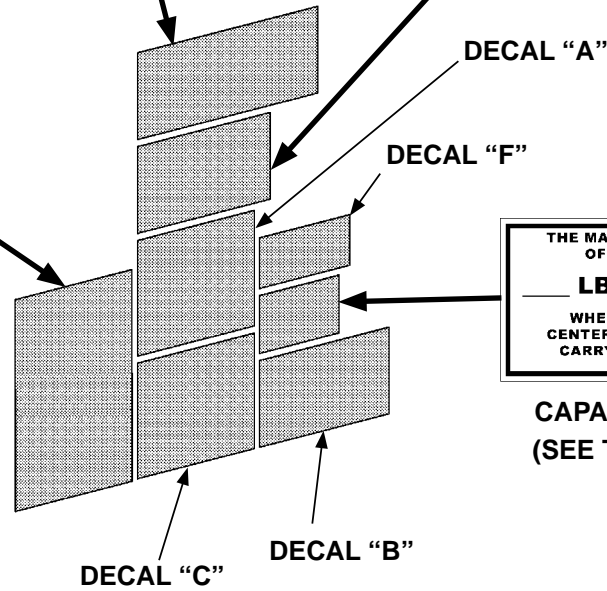

**CAPACITY DECAL
(SEE TABLE 25-1)**

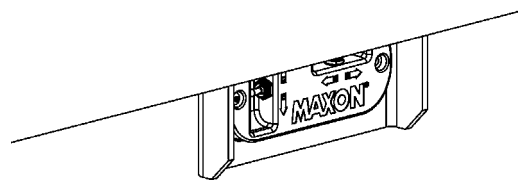

FIG. 25-1

MODEL	ORDER P/N	DECAL "C"
GPSLR/GPSLRT-35	220388-04	3500 LB (1600 KG)
GPSLR/GPSLRT-44	253155	4400 LB (2000 KG)
GPSLR/GPSLRT-55	253161	5500 LB (2500 KG)
RA-35	220388-04	3500 LB (1600 KG)
RA-45	220388-05	4500 LB (2000 KG)

**CAPACITY DECAL PART NUMBERS
TABLE 25-1**

DECALS - Continued

MAXON®

11921 Slauson Ave. Santa Fe Springs, CA. 90670 (800) 227-4116 FAX (888) 771-7713

CAUTION
Always stand clear of platform area.
 P/N 282522-01 **F**

WARNING
Read this information carefully.

- Improper operation of this Liftgate can result in serious personal injury. If you do not have a copy of the operating instructions, please obtain them from your employer, distributor, or lessor before you attempt to operate Liftgate.
- If there are signs of improper maintenance, damage to vital parts, or slippery platform surface, do not use the Liftgate until these problems have been corrected.
- If you are using a pallet jack, be sure it can be maneuvered safely.
- Do not operate a forklift on the platform.
- Do not allow any part of yours or your helper's body to be placed under, within, or around any portion of the moving Liftgate, or its mechanisms, or in a position that would trap them between the platform and the ground or truck when the Liftgate is operated.
- If a helper is riding the platform with you, make sure you are both doing so safely and that you are not in danger of coming in contact with any moving or potentially moving obstacles.
- **USE GOOD COMMON SENSE**
- If load appears to be unsafe, do not lift or lower it.

For a free copy of other manuals that pertain to this model Liftgate, please visit our website at www.maxonlift.com or call Customer Service at (800) 227-4116. P/N 282522-01 **C**

SAFETY INSTRUCTIONS
Read all decals and operation manual before operating liftgate.

1. Do not use liftgate unless you have been properly instructed and have read, and are familiar with, the operating instructions.
2. Be certain vehicle is properly and securely braked before using the liftgate.
3. Always inspect this liftgate for maintenance or damage before using it. Do not use liftgate if it shows any sign of damage or improper maintenance.
4. Do not overload
5. Make certain the area in which the platform will open and close is clear before opening or closing the platform.
6. Make certain platform area, including the area in which loads may fall from platform, is clear before and at all times during operation of liftgate.
7. This liftgate is intended for loading and unloading of cargo only. Do not use this liftgate for anything but its intended use.

P/N 282522-01 **A**

WARNING
Liftgate hazards can result in crushing or falling.
Keep hands and feet clear of pinch points.
If riding liftgate, make sure load is stable and footing is solid.
 P/N 282522-01 **B**

Read and understand all instructions and WARNINGS before use.

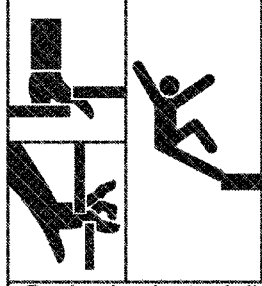

DECAL SHEET
P/N 282522-01
FIG. 26-1



MAXON PLATE
P/N 280004-01



SERIAL PLATE (REF)

WARNING
Incorrect use of battery power could result in personal injury and equipment damage. Never use the power terminals in this junction box to jump liftgate batteries that are in a low state of charge. Charge liftgate batteries directly at the battery terminals.
P/N 283023-01

BATTERY WARNING DECAL
P/N 283023-01



QR PARTS DECAL (RA ONLY)
P/N 299349-03



QR PARTS DECAL (GPSLR ONLY)
P/N 299349-04

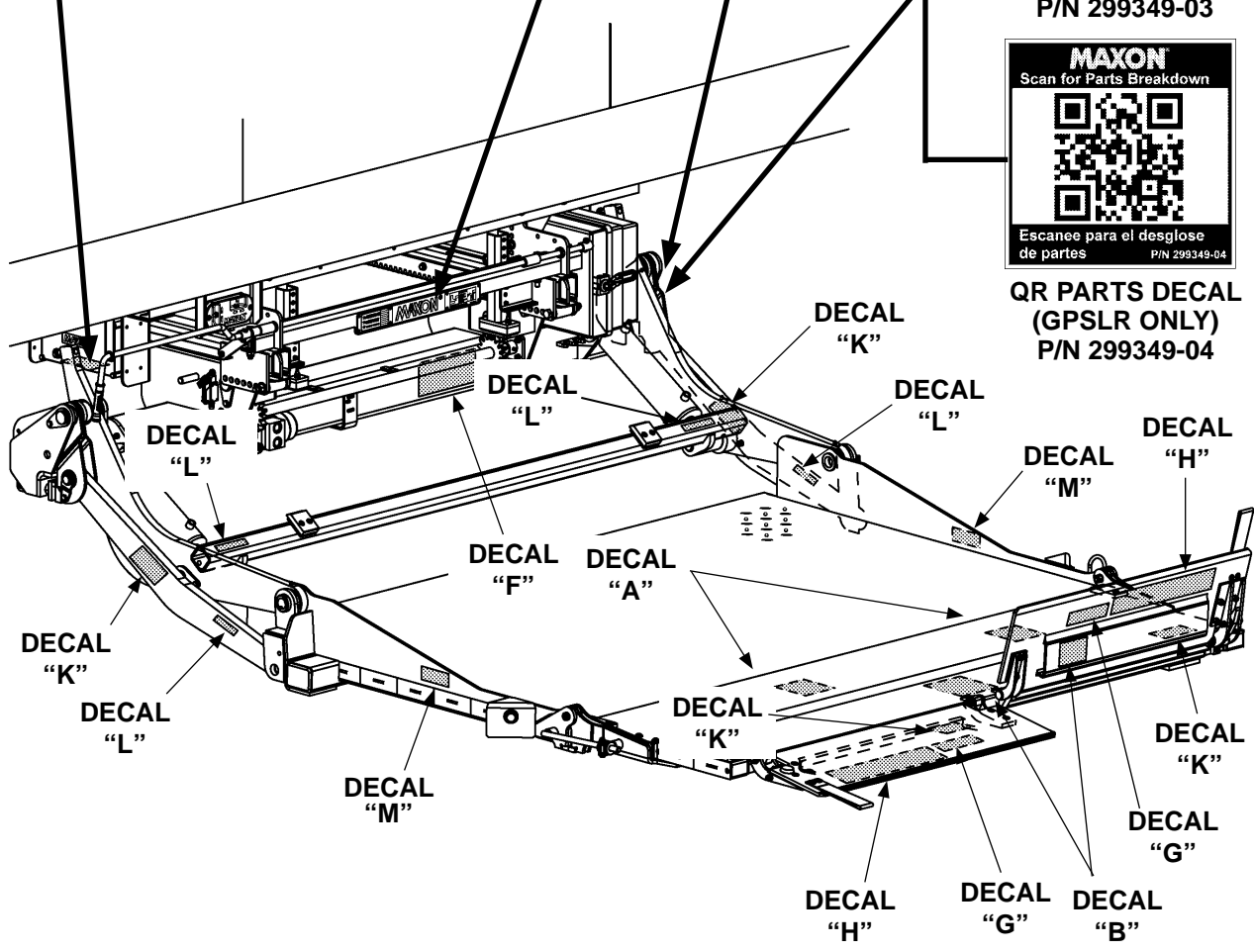

FIG. 27-1

MAXON 11921 Slauson Ave. Santa Fe Springs, CA. 90670 (800) 227-4116 FAX (888) 771-7713

DECALS - Continued

MAXON[®]

11921 Slauson Ave. Santa Fe Springs, CA. 90670 (800) 227-4116 FAX (888) 771-7713

▲ WARNING

When unstowing & stowing platform, stay clear of bumpers. **A**

▲ WARNING

To avoid injury stay out of the path where the platform unfolds. Unfold platform from the side. **B**

▲ WARNING

Keep hands clear of pinch points when folding flipover. **M**

▲ WARNING

To prevent personal injury & equipment damage, avoid working under the platform while platform is raised off the ground. Refer to Maintenance Manual for additional safety instructions. **F**

▲ WARNING

To avoid possible injury and damage to equipment, never stand on lift arms, parallel arms, or bottom side of platform. **K**

▲ WARNING

To prevent personal injury & damaged equipment, ramp must be in retention position when cart is being raised or lowered on platform. **G**

1 Push locking arm and pull strap to unlock ramp

2 Push locking arm and pull ramp

3 Push locking arm and pull ramp

4 Push ramp

5 Push ramp

Locking Arm, Strap, Ramp, Retention Position, Ramp Position, Retention Position, Stow Position **H**

▲ WARNING

Keep hands & feet clear of lifting arms.

L

DECAL SHEET P/N 267432-03
FIG. 28-1

THIS PAGE INTENTIONALLY LEFT BLANK

SYSTEM DIAGRAMS

PUMP & MOTOR SOLENOID OPERATION - SINGLE PUMP

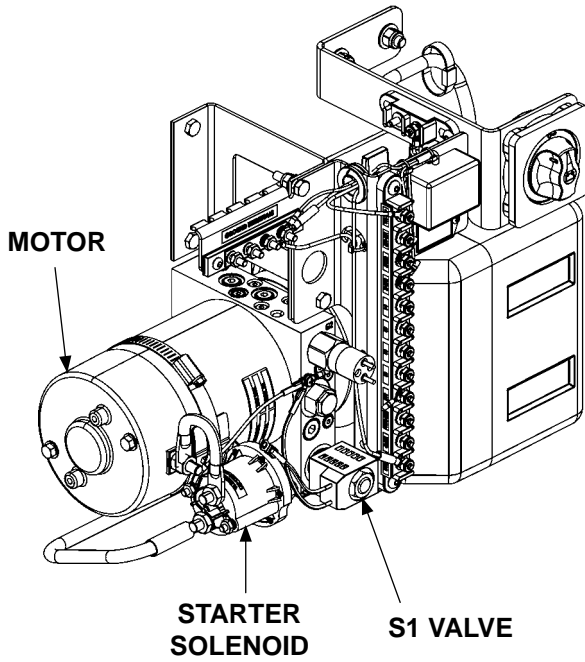

**POWER UNIT
FIG. 30-1**

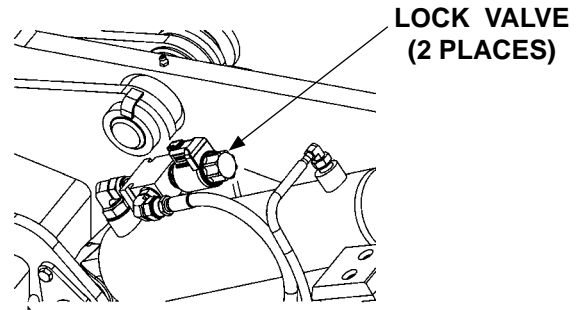

**LOCK VALVE (S2)
(RH CYLINDER SHOWN)
FIG. 30-2**

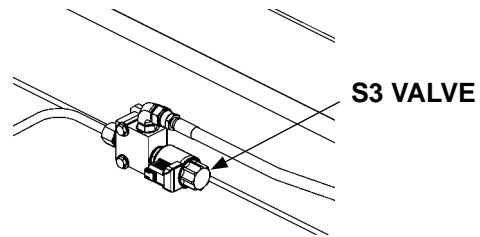

**S3 VALVE
(BI-DIRECTIONAL)
FIG. 30-3**

POWER UNIT MOTOR & SOLENOID OPERATION				
LIFTGATE FUNCTION	SOLENOID OPERATION (✓ MEANS ENERGIZED)			
	MOTOR	VALVE S1	VALVE S3	LOCK VALVES (S2 VALVES)
RAISE	✓	-	-	✓
LOWER (GD)	-	✓	-	✓
LOWER (PD)	✓	✓	-	✓
SLIDE OPEN	✓	-	✓	-
SLIDE CLOSED	✓	✓	✓	-

REFER TO VALVES SHOWN ON
HYDRAULIC SCHEMATIC

TABLE 30-1

SYSTEM DIAGRAMS - Continued

PUMP & MOTOR SOLENOID OPERATION - DUAL PUMPS

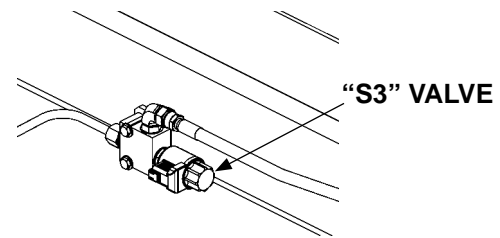
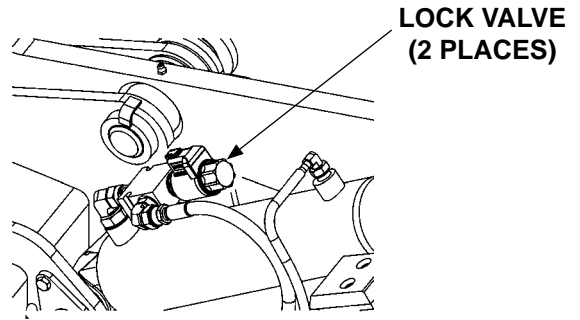
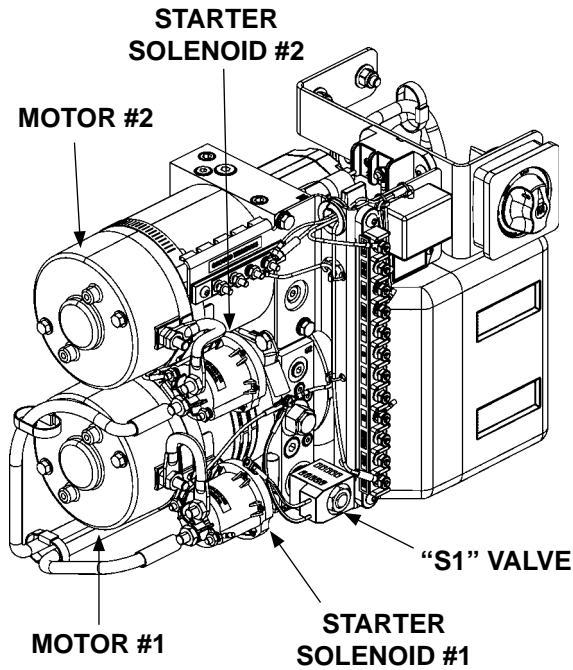

POWER UNIT MOTOR & SOLENOID OPERATION				
LIFTGATE FUNCTION	SOLENOID OPERATION (✓ MEANS ENERGIZED)			
	MOTOR (#1 OR #2)	VALVE S1	VALVE S3	LOCK VALVES ("S2" VALVES)
RAISE	✓	-	-	✓
LOWER (GD)	-	✓	-	✓
LOWER (PD)	✓	✓	-	✓
SLIDE OPEN	✓	-	✓	-
SLIDE CLOSED	✓	✓	✓	-
REFER TO VALVES SHOWN ON HYDRAULIC SCHEMATIC				

TABLE 31-1

SYSTEM DIAGRAMS - Continued

HYDRAULIC SCHEMATIC - GRAVITY DOWN

MAXON[®]

11921 Slauson Ave. Santa Fe Springs, CA. 90670 (800) 227-4116 FAX (888) 771-7713

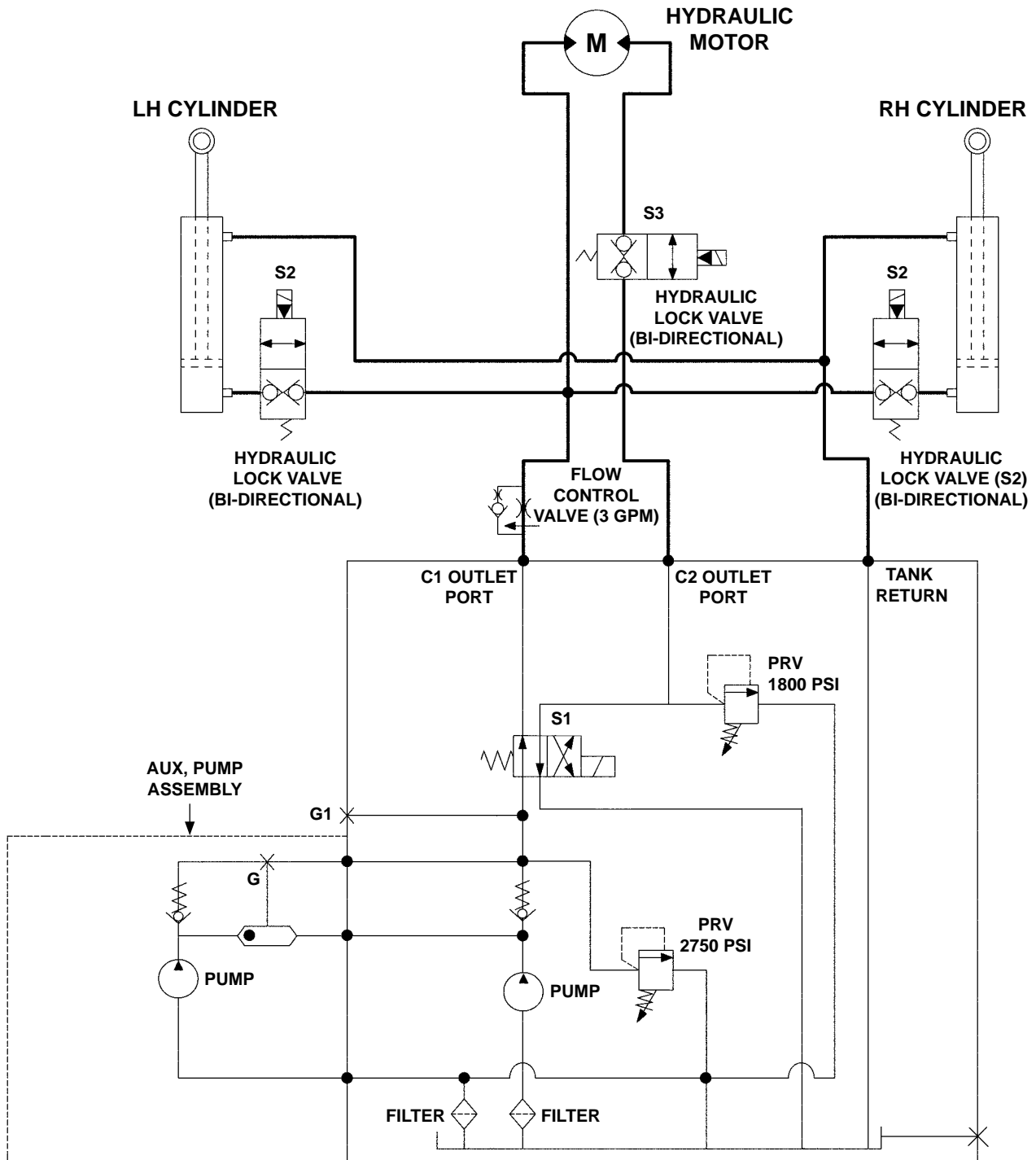

NOTE: PRV (PRESSURE RELIEF VALVE)

FIG. 32-1

HYDRAULIC SCHEMATIC - POWER DOWN

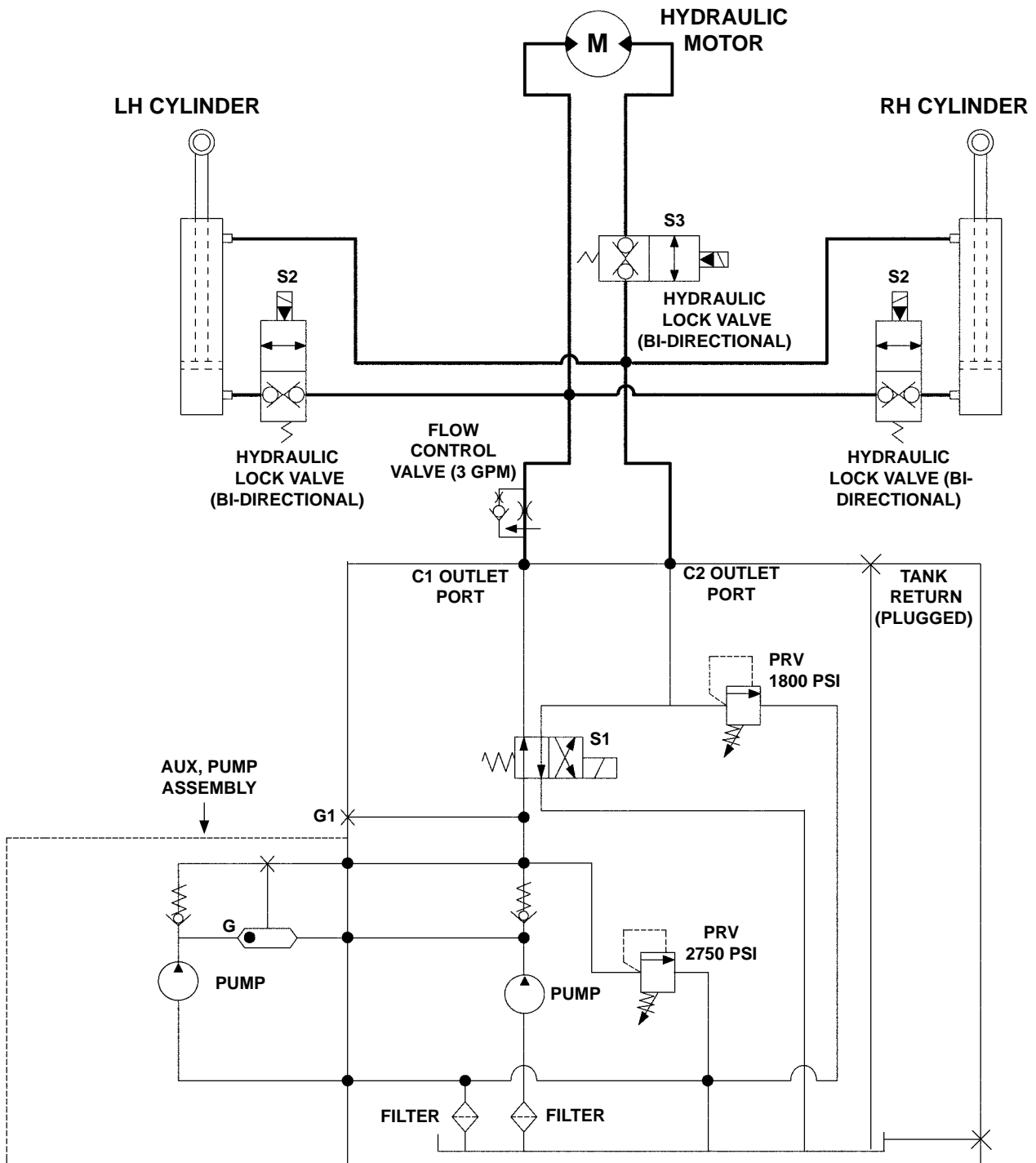

NOTE: PRV (PRESSURE RELIEF VALVE)

FIG. 33-1

SYSTEM DIAGRAMS - Continued

ELECTRICAL SCHEMATIC, 12V, GRAVITY DOWN, WITH MAX ECU

MAXON[®]

11921 Slauson Ave. Santa Fe Springs, CA. 90670 (800) 227-4116 FAX (888) 771-7713

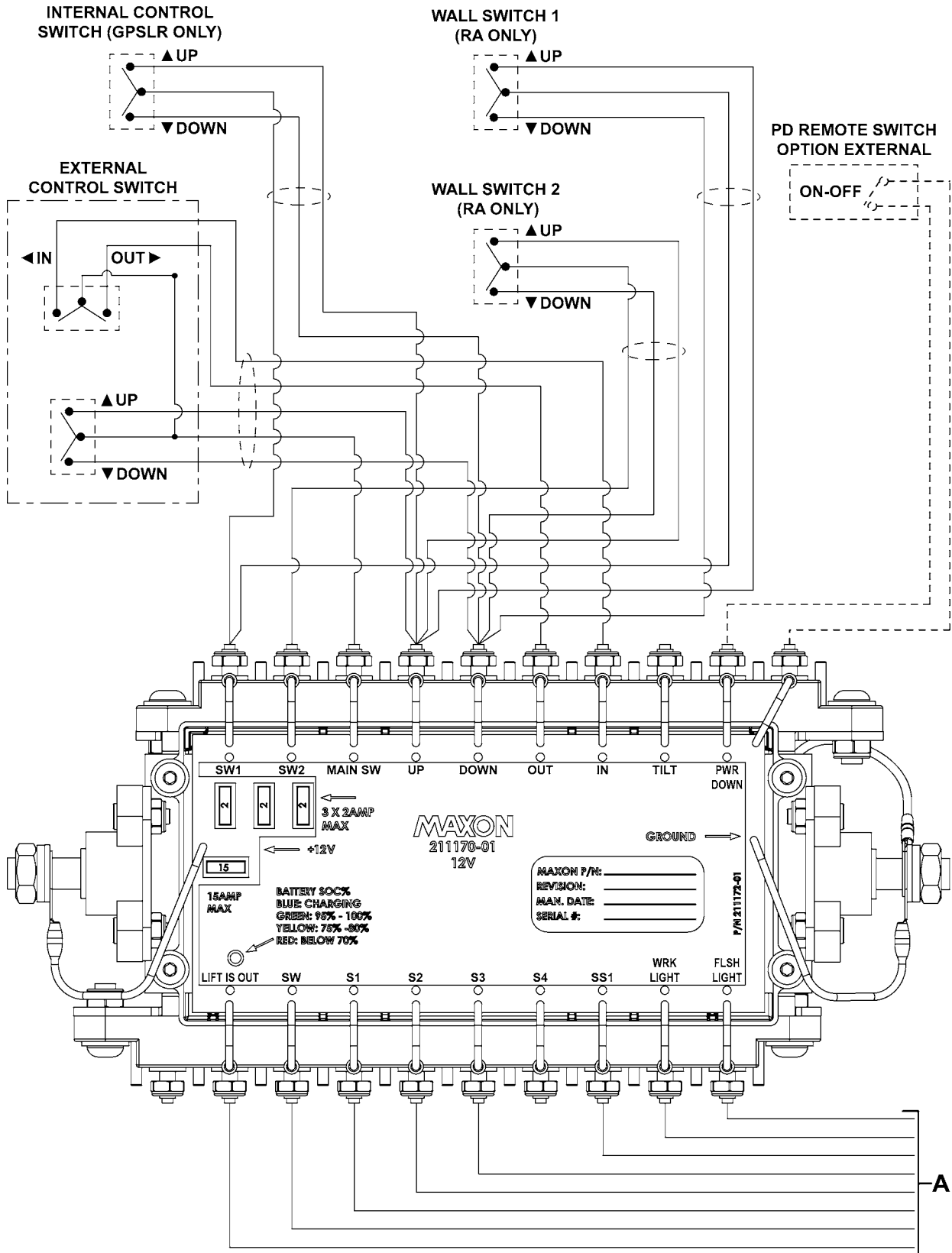

FIG. 34-1

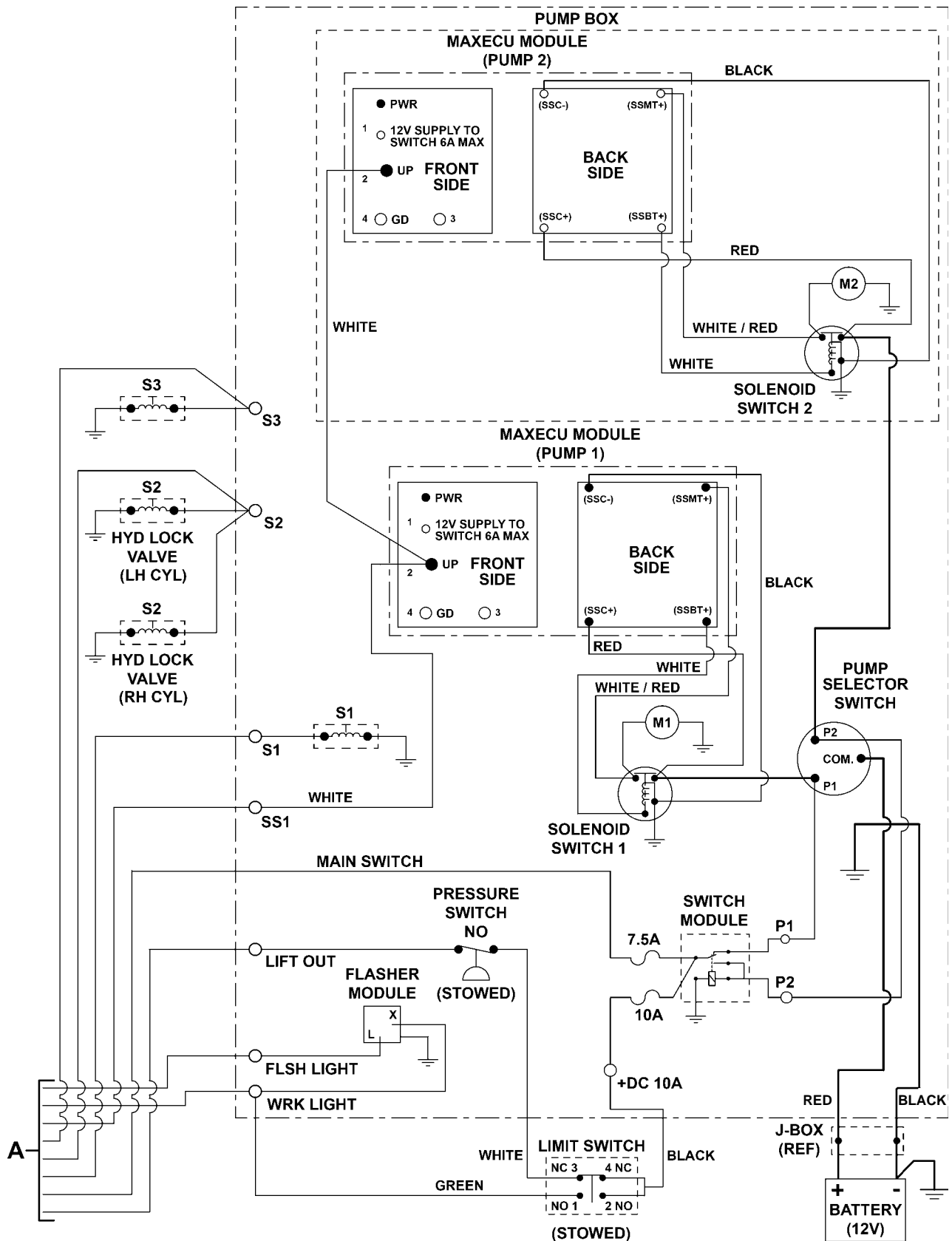

FIG. 35-1

SYSTEM DIAGRAMS - Continued

ELECTRICAL SCHEMATIC, 12V, POWER DOWN, WITH MAX ECU

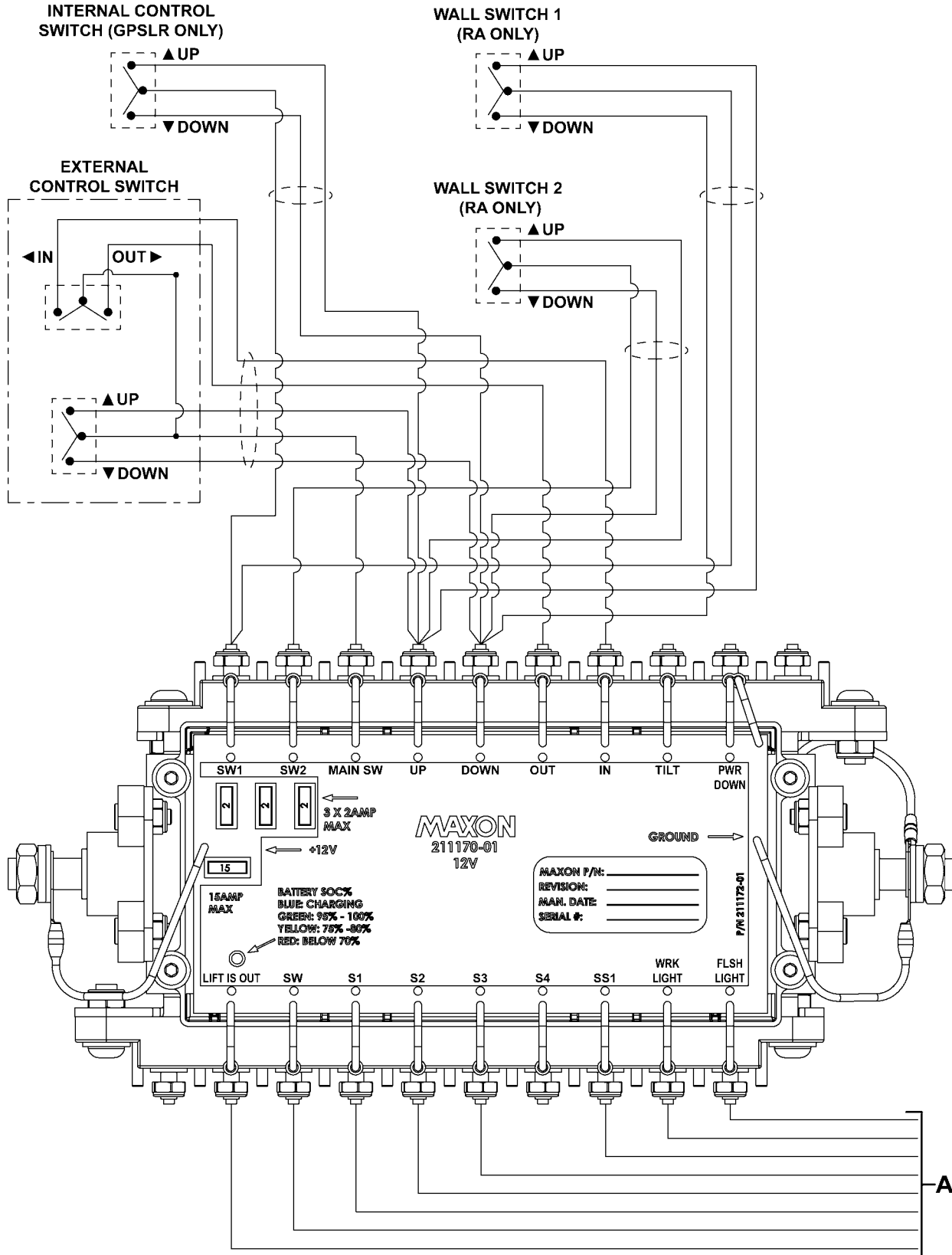

FIG. 36-1

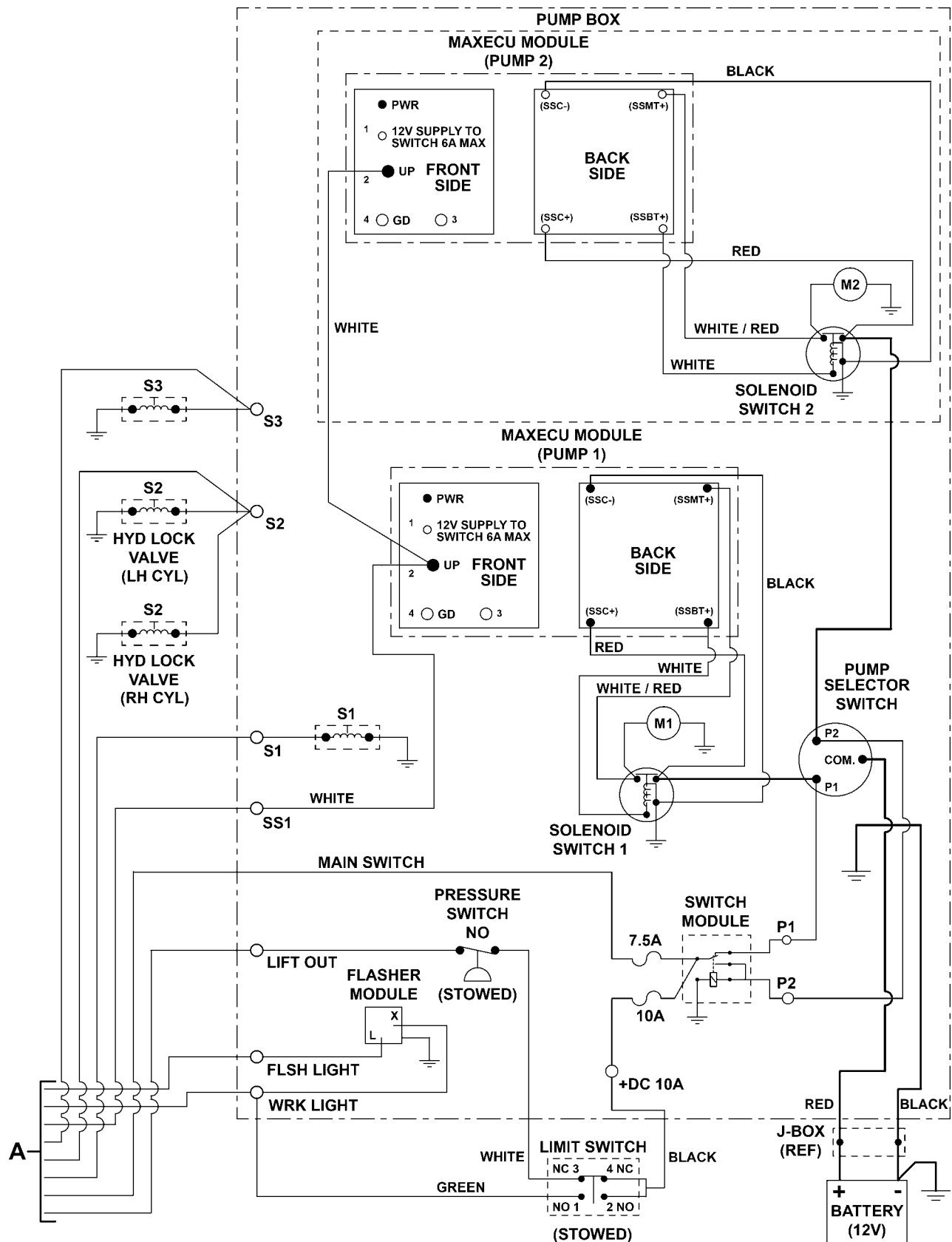

FIG. 37-1

SYSTEM DIAGRAMS - Continued

ELECTRICAL SCHEMATIC 12V/24V, GRAVITY DOWN

MAXON[®]

11921 Slauson Ave. Santa Fe Springs, CA. 90670 (800) 227-4116 FAX (888) 771-7713

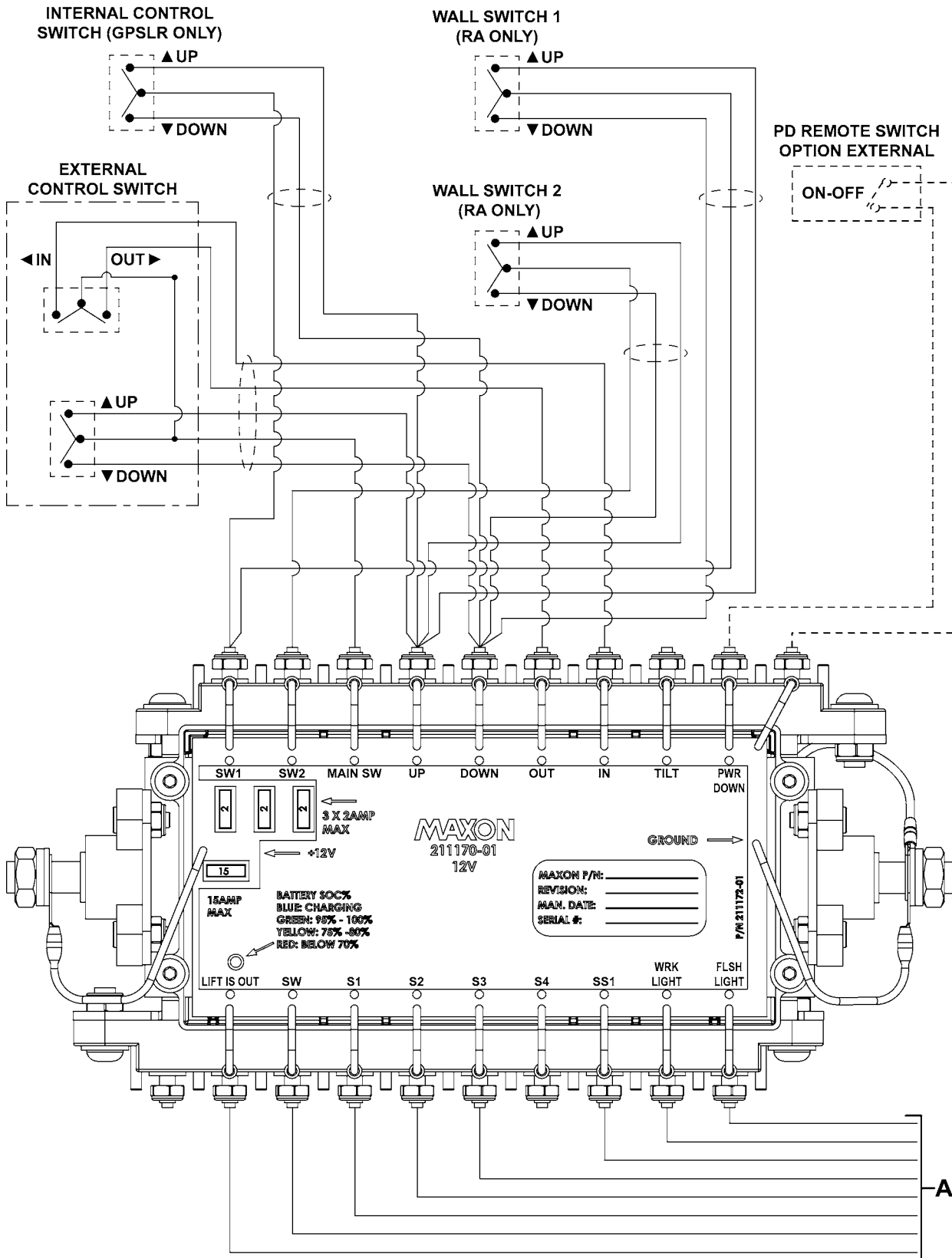

FIG. 38-1

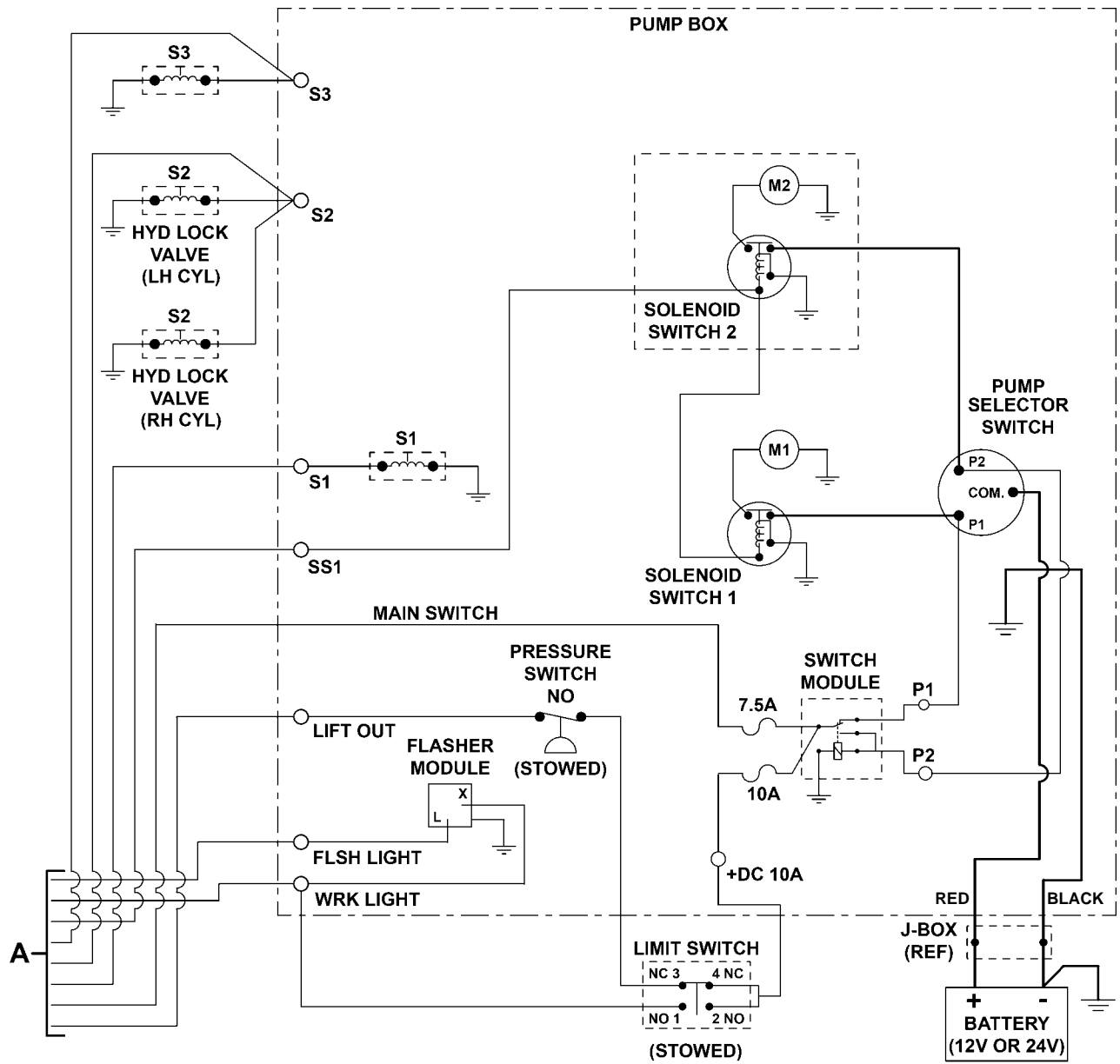

FIG. 39-1

SYSTEM DIAGRAMS - Continued

ELECTRICAL SCHEMATIC, 12V/24V, POWER DOWN

MAXON

11921 Slauson Ave. Santa Fe Springs, CA. 90670 (800) 227-4116 FAX (888) 771-7713

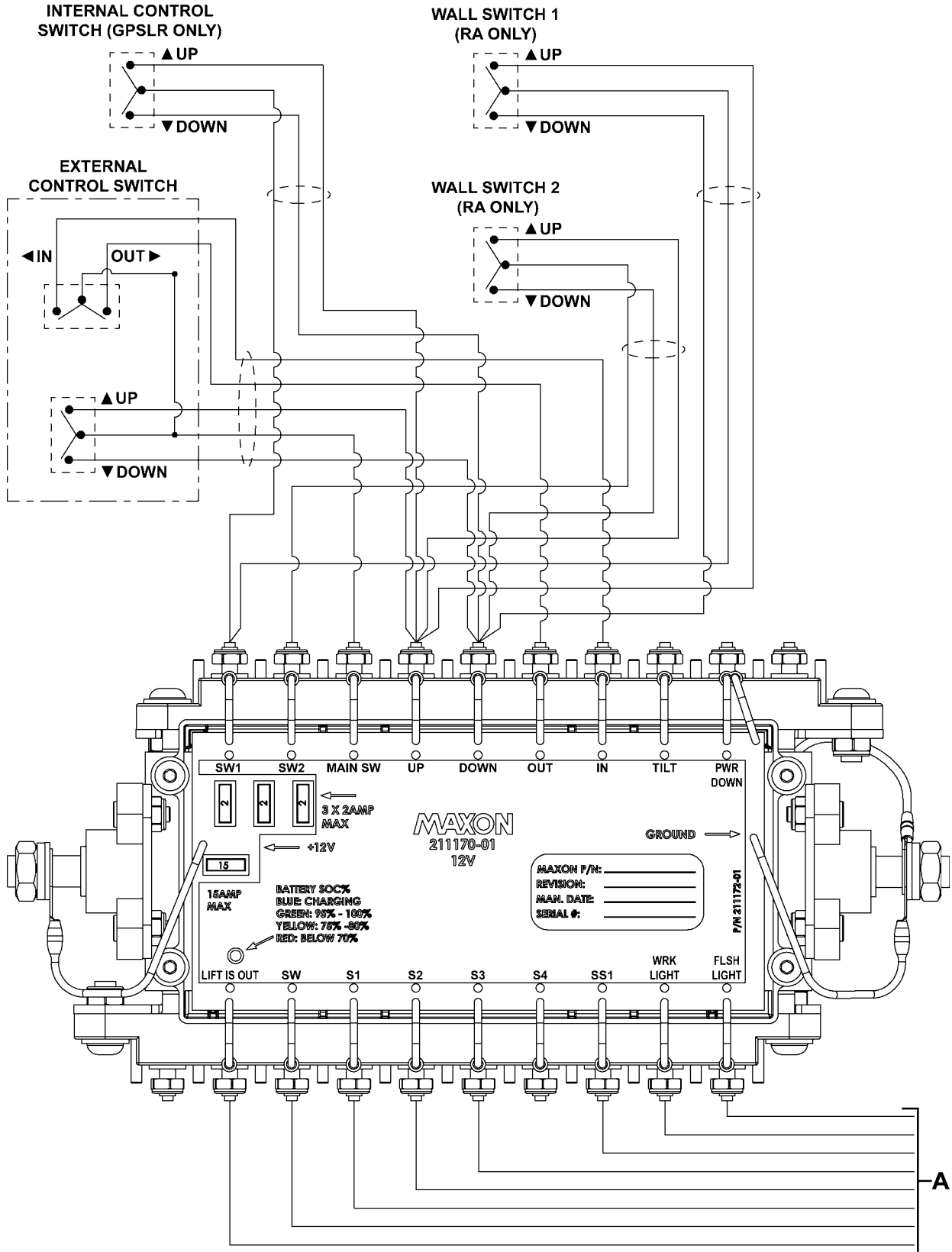

FIG. 40-1

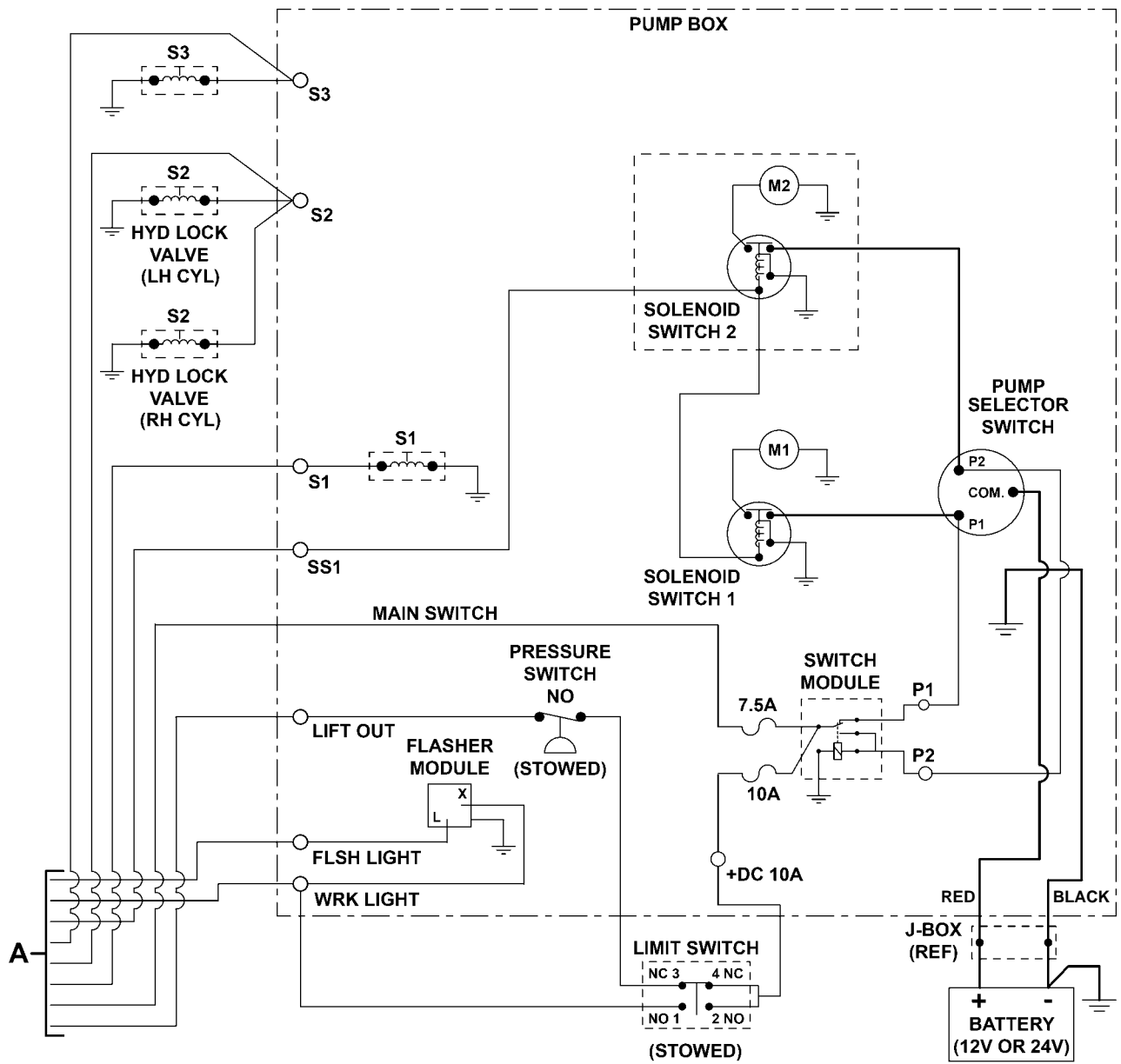

FIG. 41-1

TROUBLESHOOTING

TO BE PROVIDED IN FUTURE UPDATE

MAXON[®]

11921 Slauson Ave. Santa Fe Springs, CA. 90670 (800) 227-4116 FAX (888) 771-7713

