

M-16-40
REV. D
NOVEMBER 2024



MAXON[®]

DMD Series

MAINTENANCE MANUAL
DMD-18, DMD-22 & DMD-33

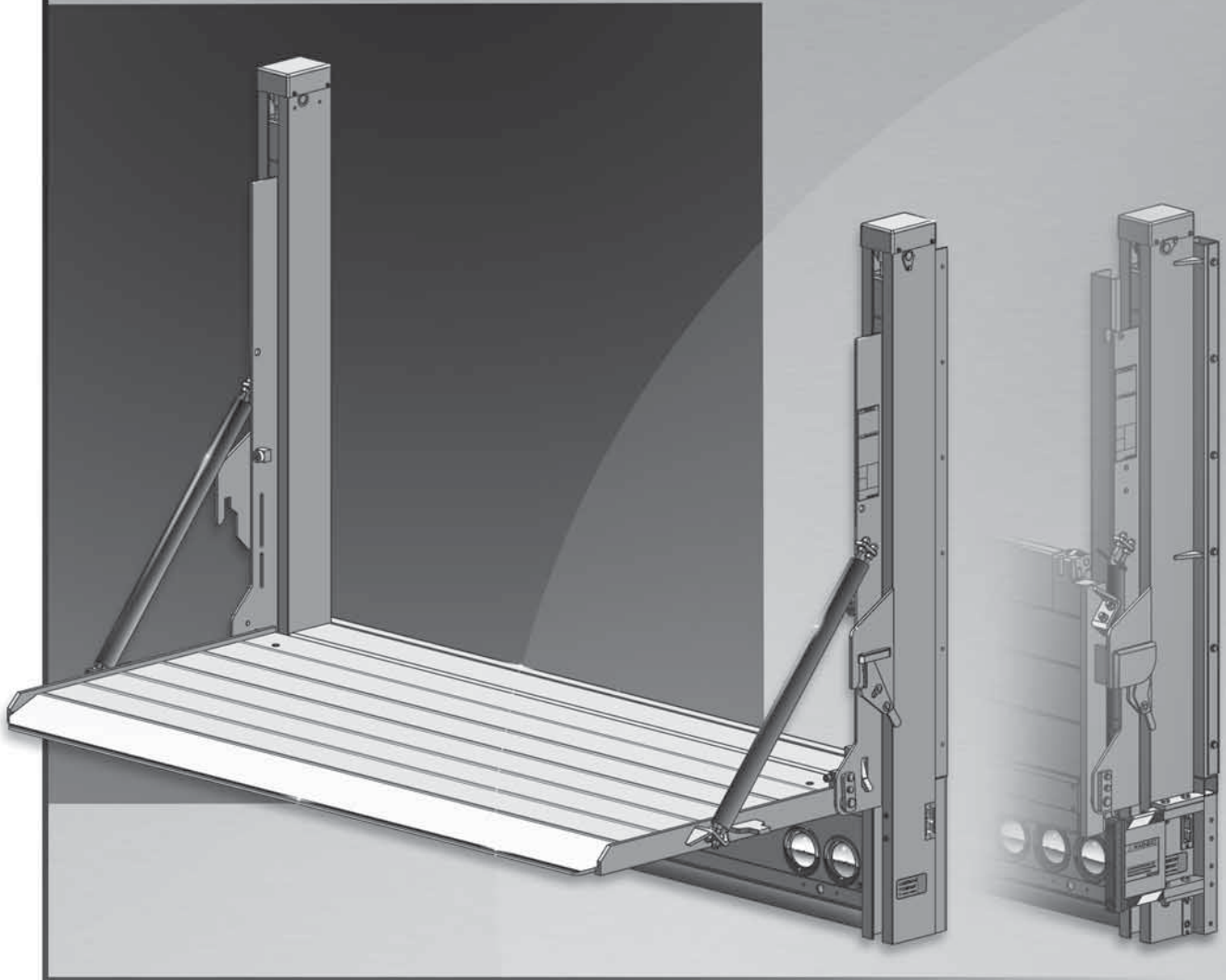

MAXON[®]

LIFT CORP.

11921 Slauson Ave.
Santa Fe Springs, CA. 90670

CUSTOMER SERVICE:

TELEPHONE (562) 464-0099 TOLL FREE (800) 227-4116

FAX: (888) 771-7713

NOTE: For latest version of all Manuals (and replacements), download the
Manuals from Maxon's website at www.maxonlift.com.

WARRANTY/ RMA POLICY & PROCEDURE

LIFTGATE WARRANTY

Type of Warranty: Full Parts and Labor

Term of Warranty: Standard Liftgates - 2 years from ship date or 6,000 cycles
Premium Liftgates - 2 years from ship date or 10,000 cycles

This warranty shall not apply unless the product is installed, operated and maintained in accordance with MAXON Lift's specifications as set forth in MAXON Lift's Installation, Operation and Maintenance manuals. This warranty does not cover normal wear, maintenance or adjustments, damage or malfunction caused by improper handling, installation, abuse, misuse, negligence, or carelessness of operation. In addition, this warranty does not cover equipment that has had unauthorized modifications or alterations made to the product.

MAXON agrees to replace any components which are found to be defective during the first 2 years of service, and will reimburse for labor based on MAXON's Liftgate Warranty Flat Rate Schedule. (Copy of the Flat Rate is available at www.maxonlift.com.)

All warranty repairs must be performed by an authorized MAXON warranty facility. For any repairs that may exceed \$500, including parts and labor, MAXON's Technical Service Department must be notified and an "Authorization Number" obtained.

All claims for warranty must be received within 30 Days of the repair date, and include the following information:

1. Liftgate Model Number and Serial Number
2. The End User must be referenced on the claim
3. Detailed Description of Problem
4. Corrective Action Taken, and Date of Repair
5. Parts used for Repair, Including MAXON Part Number(s)
6. MAXON R.M.A. # and/or Authorization # if applicable (see below)
7. Person contacted at MAXON if applicable
8. Claim must show detailed information i.e. Labor rate and hours of work performed

Warranty claims can also be placed online at www.maxonlift.com. Online claims will be given priority processing.

All claims for warranty will be denied if paperwork has not been received or claim submitted via Maxon website for processing by MAXON's Warranty Department within 30 days of repair date.

All components may be subject to return for inspection, prior to the claim being processed. MAXON products may not be returned without prior written approval from MAXON's Technical Service Department. Returns must be accompanied by a copy of the original invoice or reference with original invoice number and are subject to a credit deduction to cover handling charges and any necessary reconditioning costs. **Unauthorized returns will be refused and will become the responsibility of the returnee.**

Any goods being returned to MAXON Lift must be pre-approved for return, and have the R.M.A. number written on the outside of the package in plain view, and returned freight prepaid. All returns are subject to a 15% handling charge if not accompanied by a detailed packing list. Returned parts are subject to no credit and returned back to the customer. Defective parts requested for return must be returned within 30 days of the claim date for consideration to:

MAXON Lift Corp.
10321 Greenleaf Ave., Santa Fe Springs, CA 90670
Attn: RMA# _____

MAXON's warranty policy does not include the reimbursement for travel time, towing, vehicle rental, service calls, oil, batteries or loss of income due to downtime. Fabrication or use of non Maxon parts, which are available from MAXON, are also not covered.

MAXON's Flat Rate Labor Schedule takes into consideration the time required for diagnosis of a problem.

All Liftgates returned are subject to inspection and a 15% restocking fee. Any returned Liftgates or components that have been installed or not returned in new condition will be subject to an additional reworking charge, which will be based upon the labor and material cost required to return the Liftgate or component to new condition.

PURCHASE PART WARRANTY

Term of Warranty: 1 Year from Date of Purchase.

Type of Warranty: Part replacement only. MAXON will guarantee all returned genuine MAXON replacement parts upon receipt and inspection of parts and original invoice.

All warranty replacements parts will be sent out via ground freight. If a rush shipment is requested, all freight charges will be billed to the requesting party.

TABLE OF CONTENTS

SUMMARY OF CHANGES: M-16-40 REVISION D	6
WARNINGS	7
SAFETY INSTRUCTIONS	8
LIFTGATE TERMINOLOGY	9
PERIODIC MAINTENANCE	11
PERIODIC MAINTENANCE CHECKS	11
PREVENTATIVE MAINTENANCE (PM) CHECKLIST.....	12
CHECKING HYDRAULIC FLUID	13
CHANGING HYDRAULIC FLUID	15
TORSION BAR ADJUSTMENT	17
MEASURE & ADJUST CLEARANCE FOR PLATFORM WITH FLIPOVER.....	34
DECALS	37
DECALS & PLATES	40
SYSTEM DIAGRAMS	42
PUMP MOTOR & VALVE OPERATION (MANUAL CLOSE).....	42
PUMP MOTOR & VALVE OPERATION (EQUIPPED WITH HYDRAULIC CLOSER).....	43
HYDRAULIC SCHEMATIC (MANUAL CLOSE)	44
HYDRAULIC SCHEMATIC (EQUIPPED WITH HYDRAULIC CLOSER).....	45
ELECTRICAL SCHEMATIC (MANUAL CLOSE)	46
ELECTRICAL SCHEMATIC (EQUIPPED WITH HYDRAULIC CLOSER).....	47
ELECTRICAL SCHEMATIC - JUMPER HARNESS ASSEMBLY	48
ELECTRICAL SCHEMATIC - HOUSING COVER ASSEMBLY (WITHOUT LIGHTS).....	49
ELECTRICAL SCHEMATIC - HOUSING COVER ASSEMBLY (WITH FOUR LIGHTS)....	50
ELECTRICAL SCHEMATIC - HOUSING COVER ASSEMBLY, FOREIGN VEHICLE (WITH 6 LIGHTS).....	51

DMD ELECTRICAL VALUES & TORQUE SPECIFICATIONS	52
BOLT TORQUES	53

SUMMARY OF CHANGES: M-16-40 REVISION D

PAGE	DESCRIPTION OF CHANGE
COVER	Updated REV and date of release. Added DMD with dock bumper image.
10	Added DMD with dock bumpers Terminology page.
37	Added WARNING decal P/N 212449-01.
37, 39	Replaced decal sheet P/N 298155-03 with P/N 212464-01.
38, 41	Added decal pages for DMD with dock bumpers.

Comply with the following **WARNINGS** and **SAFETY INSTRUCTIONS** while maintaining Liftgates. See Operation Manual for operating safety requirements.

WARNING

Installing and maintaining a liftgate can expose you to chemicals, including lead, which are known to the State of California to cause cancer and birth defects or other reproductive harm. To minimize exposure, install and maintain liftgate in a well-ventilated area and wear **proper Personal protective equipment (PPE)**. For more information go to www.P65Warnings.ca.gov.

WARNING

- Do not stand, or allow obstructions, under the platform when lowering the Liftgate. **Be sure your feet are clear of the Liftgate.**
- **Keep fingers, hands, arms, legs, and feet clear of moving Liftgate parts (and platform edges) when operating the Liftgate.**
- **Correctly stow platform when not in use. Extended platforms could create a hazard for people and vehicles passing by.**
- **Disconnect Liftgate power cable from battery** before repairing or servicing Liftgate.
- If it is necessary to stand on the platform while maintaining the Liftgate, keep your feet and any objects clear of the inboard edge of the platform. Your feet or objects on the platform can become trapped between the platform and the Liftgate housing cover.
- Recommended practices for welding on steel parts are contained in the current **AWS (American Welding Society) D1.1 Structural Welding Code - Steel**. Damage to Liftgate and/or vehicle, and personal injury could result from welds that are done incorrectly.
- Recommended practices for welding on aluminum parts are contained in the current **AWS (American Welding Society) D1.2 Structural Welding Code - Aluminum**. Damage to Liftgate and/or vehicle, and personal injury could result from welds that are done incorrectly.

SAFETY INSTRUCTIONS

- Read and understand the instructions in this **Maintenance Manual** before performing maintenance on the Liftgate.
- Before operating the Liftgate, read and understand the operating instructions in **Operation Manual**.
- Comply with all **WARNING** and instruction decals attached to the Liftgate.
- Keep decals clean and legible. If decals are illegible or missing, replace them. Free replacement decals are available from **Maxon Customer Service**.
- Consider the safety and location of bystanders and location of nearby objects when operating the Liftgate. Stand to one side of the platform while operating the Liftgate.
- Do not allow untrained persons to operate the Liftgate.
- Wear appropriate safety equipment such as protective eyeglasses, faceshield and clothing while performing maintenance on the Liftgate and handling the battery. Debris from drilling and contact with battery acid may injure unprotected eyes and skin.
- Be careful working by an automotive type battery. Make sure the work area is well ventilated and there are no flames or sparks near the battery. Never lay objects on the battery that can short the terminals together. If battery acid gets in your eyes, immediately seek first aid. If acid gets on your skin, immediately wash it off with soap and water.
- If an emergency situation arises (vehicle or Liftgate) while operating the Liftgate, release the control switch to stop the Liftgate.
- A correctly installed Liftgate operates smoothly and reasonably quiet. The only noticeable noise during operation comes from the power unit while the platform is raised. Listen for scraping, grating and binding noises and correct the problem before continuing to operate Liftgate.
- Use only **Maxon Authorized Parts** for replacement parts. Provide Liftgate model and serial number information with your parts order. Order replacement parts from:

MAXON LIFT CORP. Customer Service
11921 Slauson Ave., Santa Fe Springs, CA 90670

Online: www.maxonlift.com
Express Parts Ordering: Phone (800) 227-4116 ext. 4345
Email: Ask your Customer Service representative

MAXON®

11921 Slauson Ave. Santa Fe Springs, CA 90670 (800) 227-4116 FAX (888) 771-7713

LIFTGATE TERMINOLOGY

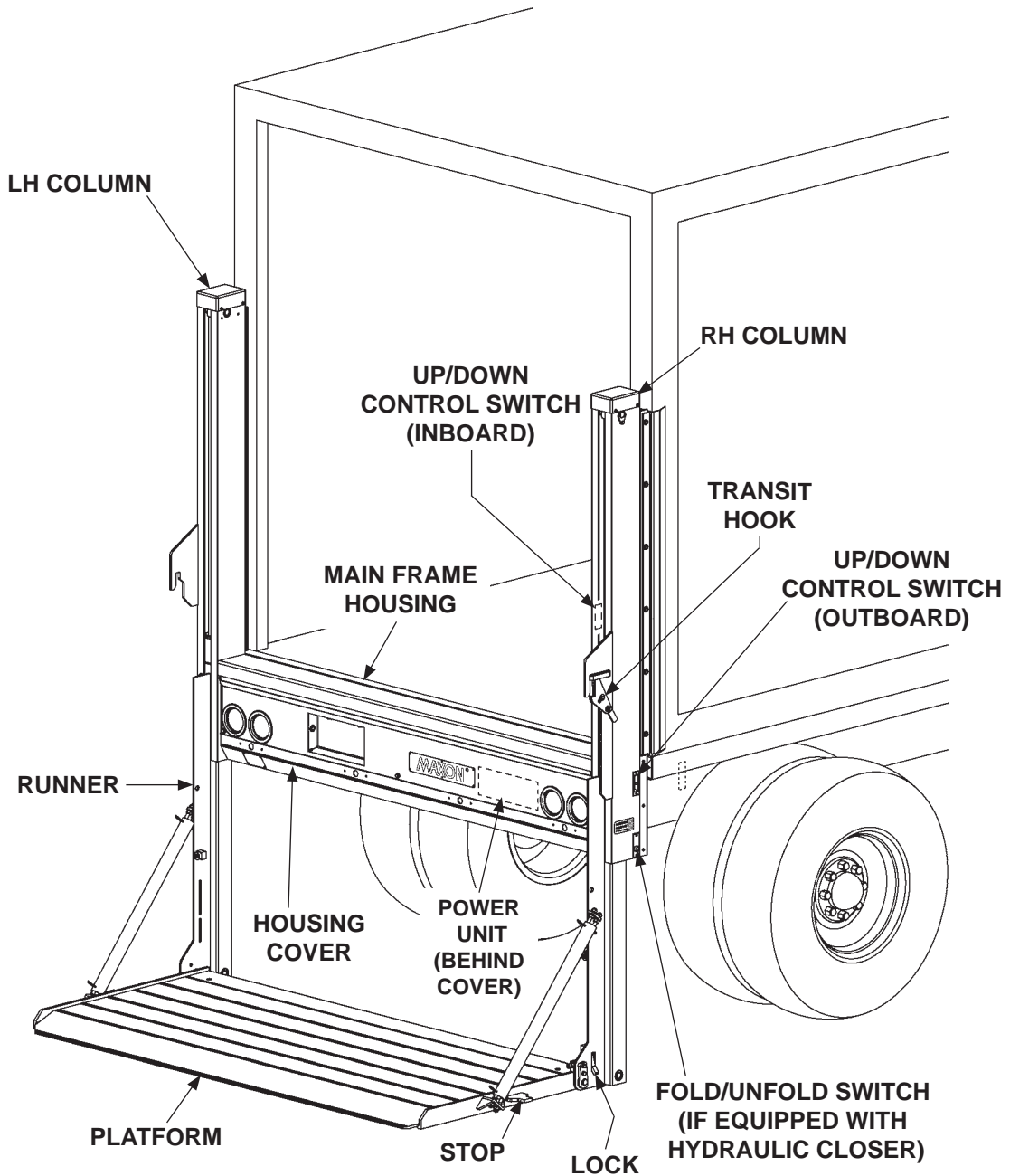

LIFTGATE TERMINOLOGY - DMD WITH DOCK BUMPERS

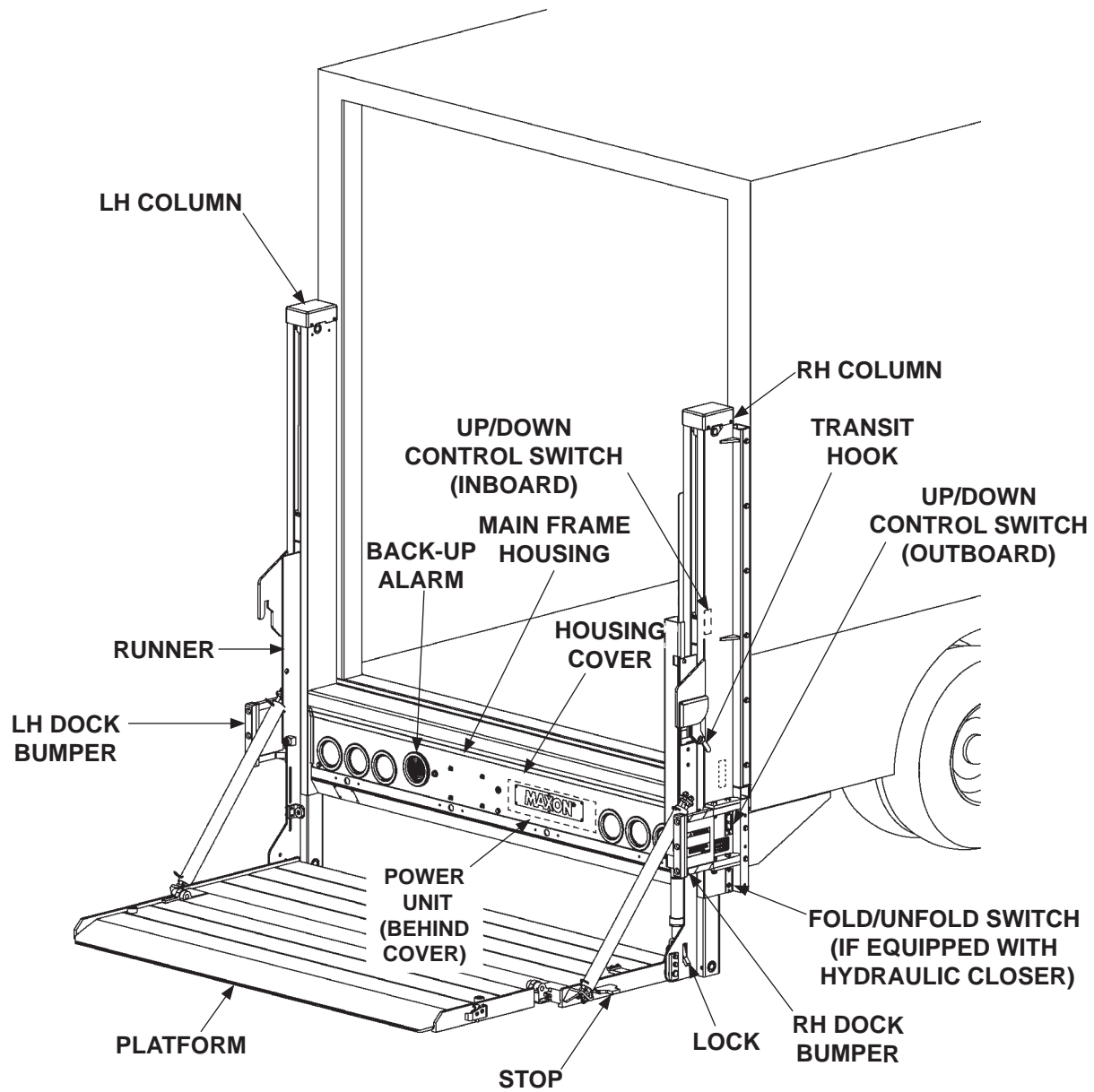

MAXON®

11921 Slauson Ave. Santa Fe Springs, CA. 90670 (800) 227-4116 FAX (888) 771-7713

PERIODIC MAINTENANCE

PERIODIC MAINTENANCE CHECKS

WARNING

Never operate the Liftgate with parts loose or missing.

NOTE: Photocopy the PM CHECKLIST on the next page to help keep track of periodic maintenance on the Liftgate. Keep completed form with maintenance records.

NOTE: When replacing parts, refer to the Parts Portal on the Maxon website for genuine MAXON replacement parts.

Quarterly or 1250 Cycles (whichever occurs first)

Check the hydraulic fluid level in the pump reservoir. Refer to the **CHECKING HYDRAULIC FLUID** procedure in the **PERIODIC MAINTENANCE** section.

- If hydraulic fluid appears contaminated, refer to the **CHANGING HYDRAULIC FLUID** procedure on following page.
- Keep track of the grade of hydraulic fluid in the pump reservoir. Never mix two different grades of fluid.
- Check lines and fittings for chaffing and fluid leaks. Replace if necessary.
- Check electrical wiring for chaffing and make sure wiring connections are tight and free of corrosion, and coated with electrical sealant (EP-03, REV. H).
- Check that all **WARNING** and **instruction decals** are in place and legible.
- Check for loose or missing nuts, bolts, covers, roll pins, screws and pins.
- Check that platform latch and transit hook mechanisms work correctly and no parts are missing.

CAUTION

Damaged cylinder seals and contaminated hydraulic fluid can result from painting the polished portion of the cylinder rod. To prevent damage, protect the exposed polished portion of the cylinder rod while painting.

- Check for rust and oily surfaces on Liftgate. If there is rust or oil on the Liftgate, clean it off. If cleaning platform, ensure inside columns, runners and slide pads are free of corrosion, residue, dirt and debris.

Check the clearance between main housing and bottom of flipover if the platform has a flipover. Refer to **MEASURE & ADJUST CLEARANCE FOR PLATFORM WITH FLIPOVER** in the **PERIODIC MAINTENANCE** section.

Annually or 5000 Cycles (whichever occurs first)

- Visually check the entire Liftgate for excessively worn parts and broken welds, especially check the platform hinge pins for excessive wear and broken welds.
- Perform all **Quarterly Maintenance** checks.

PERIODIC MAINTENANCE PREVENTATIVE MAINTENANCE (PM) CHECKLIST

PM Interval: 3 Months

Date: ___ / ___ / ___

Equipment: _____ W/O # _____ Location: _____

Mechanic: _____ Serial # _____ Model # _____

Check Appropriate Box. "☐"

MAXON Quarterly / 1250 Cycles Liftgate Preventative Maintenance (PM) Procedures				
<input type="checkbox"/> Satisfactory	<input type="checkbox"/> Repair required	<input type="checkbox"/> Corrected	1	Verify if the Quarterly or Annual PM is due by checking the PM sticker on the curbside Liftgate column.
<input type="checkbox"/> Satisfactory	<input type="checkbox"/> Repair required	<input type="checkbox"/> Corrected	2	Check for oil leaks at: cylinders, valves, and fittings.
<input type="checkbox"/> Satisfactory	<input type="checkbox"/> Repair required	<input type="checkbox"/> Corrected	3	Check for damage: platform, column, runners and hydraulic tubes.
<input type="checkbox"/> Satisfactory	<input type="checkbox"/> Repair required	<input type="checkbox"/> Corrected	4	Check for loose or missing nuts, bolts, covers, roll pins, screws and pins.
<input type="checkbox"/> Satisfactory	<input type="checkbox"/> Repair required	<input type="checkbox"/> Corrected	5	Check for cracked welds at: columns, runners, platform, main housing and vehicle door frame.
<input type="checkbox"/> Satisfactory	<input type="checkbox"/> Repair required	<input type="checkbox"/> Corrected	6	Check platform lowering speed: Range is 16 - 30 seconds. Check cylinder lock valves for proper operation.
<input type="checkbox"/> Satisfactory	<input type="checkbox"/> Repair required	<input type="checkbox"/> Corrected	7	Check platform pins and couplers.
<input type="checkbox"/> Satisfactory	<input type="checkbox"/> Repair required	<input type="checkbox"/> Corrected	8	Check platform raising speed: Range is 12-13 seconds.
<input type="checkbox"/> Satisfactory	<input type="checkbox"/> Repair required	<input type="checkbox"/> Corrected	9	Check that platform unlatches, unfolds & folds smoothly & latches securely.
<input type="checkbox"/> Satisfactory	<input type="checkbox"/> Repair required	<input type="checkbox"/> Corrected	10	Check switches and wiring connections on Liftgate as well as pump inside main housing. Also check ground straps.
<input type="checkbox"/> Satisfactory	<input type="checkbox"/> Repair required	<input type="checkbox"/> Corrected	11	Check the gear pump for unusual noise, i.e. squealing or extreme RPM output.
<input type="checkbox"/> Satisfactory	<input type="checkbox"/> Repair required	<input type="checkbox"/> Corrected	12	Checking Oil Level: gravity down with the platform unfolded and on the ground. Oil level should be as shown in Installation Manual, " CHECKING HYDRAULIC FLUID ". Check for contamination, change if needed.
<input type="checkbox"/> Satisfactory	<input type="checkbox"/> Repair required	<input type="checkbox"/> Corrected	13	Check batteries: fully charged, load test, corrosion, cables, and hold downs.
<input type="checkbox"/> Satisfactory	<input type="checkbox"/> Repair required	<input type="checkbox"/> Corrected	14	Check all charging and ground cable connections.
<input type="checkbox"/> Satisfactory	<input type="checkbox"/> Repair required	<input type="checkbox"/> Corrected	15	Complete a new PM sticker and install it on the curbside column of the Liftgate. The next PM date is 3 months from the completed PM date. Indicate on the PM sticker if 1 st , 2 nd , 3 rd or 4 th PM.
<input type="checkbox"/> Satisfactory	<input type="checkbox"/> Repair required	<input type="checkbox"/> Corrected	16	Check that platform latch and transit hook mechanisms work correctly and no parts are missing.
<input type="checkbox"/> Satisfactory	<input type="checkbox"/> Repair required	<input type="checkbox"/> Corrected	17	Check clearance between main housing & bottom plates of flipover section with platform stowed. Refer to MEASURE & ADJUST CLEARANCE FOR PLATFORM WITH FLIPOVER in PERIODIC MAINTENANCE section. Do the adjustment if clearance is incorrect.
<input type="checkbox"/> Satisfactory	<input type="checkbox"/> Repair required	<input type="checkbox"/> Corrected	18	Check clearance between main housing & bottom plates of flipover section Check platform and flipover for cracks, holes, and bends on the load carrying surfaces and side plates. Also, make sure retention ramps and carts stops (if equipped) are undamaged and operate smoothly.

MAXON Annual / 5000 Cycles Liftgate Preventative Maintenance (PM) Procedures				
<input type="checkbox"/> Satisfactory	<input type="checkbox"/> Repair required	<input type="checkbox"/> Corrected	18	Change hydraulic fluid.
<input type="checkbox"/> Satisfactory	<input type="checkbox"/> Repair required	<input type="checkbox"/> Corrected	19	Inspect wear on slide pads.

For more detailed information, refer to the Parts Portal on the Maxon website for genuine **MAXON** replacement parts.

MAXON[®]

11921 Slauson Ave. Santa Fe Springs, CA. 90670 (800) 227-4116 FAX (888) 771-7713

CHECKING HYDRAULIC FLUID

CAUTION

Keep dirt, water and other contaminants from entering the hydraulic system. Before opening the hydraulic fluid reservoir filler cap, drain plug and hydraulic lines, clean up contaminants that can get in the openings. Also, protect the openings from accidental contamination. Never mix synthetic fluids with conventional hydraulic fluids. Hydraulic system must be purged if the fluids are mixed.

NOTE: Liftgate is shipped with **Exxon Univis HVI-13** hydraulic fluid in the hydraulic cylinders. **Exxon Univis HVI-13** hydraulic fluid is recommended for operating temperatures of **-40 to +120° F**. Refer to decal in pump box. Under certain conditions, other brands and grades of oil may be used as substitutes for the recommended oil. Refer to **TABLE 14-1**.

NOTE: If the hydraulic fluid in the reservoir is contaminated, do the **CHANGING HYDRAULIC FLUID** procedure in this section.

1. Unfold and lower platform to the ground (**FIG. 13-1**). Refer to **Operation Manual** for detailed operating instructions.
2. Unbolt and remove cover from main housing as shown in **FIG. 13-1**.
3. Check the hydraulic fluid level in reservoir as follows. With platform on the ground, level should be as shown in **FIG. 13-2**.
4. If needed, add fluid to the reservoir as follows. Remove filler cap (**FIG. 13-2**). Fill the reservoir with hydraulic fluid to level shown in **FIG. 13-2**. Reinstall filler cap.

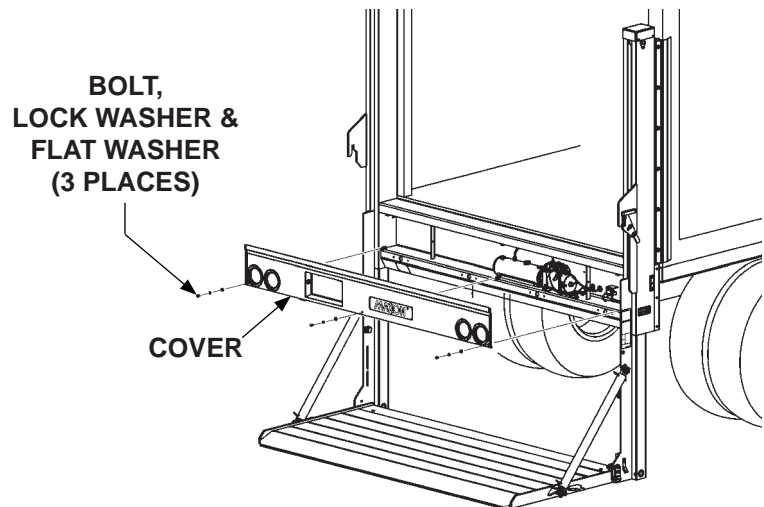

UNBOLTING/ BOLTING COVER
FIG. 13-1

CAUTION

Main housing cover must be correctly secured to prevent it from becoming a hazard.

5. Bolt cover in place on the main housing (**FIG. 13-1**). Torque the 5/16"-18 cover bolts from **10 to 14 lb-ft**.

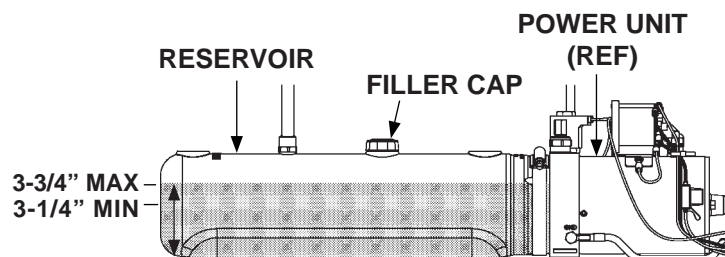

POWER UNIT FLUID LEVEL
(MANUAL CLOSE POWER UNIT SHOWN)
FIG. 13-2

PERIODIC MAINTENANCE - Continued

ISO 15 OR MIL-H-5606 HYDRAULIC OIL	
RECOMMENDED BRANDS	PART NUMBER
CHEVRON	FLUID A, AW-MV-15
KENDALL	GLACIAL BLU
SHELL	TELLUS S2 VX 15
EXXONMOBIL	UNIVIS HVI-13
ROSEMEAD	THS FLUID 17111

TABLE 14-1

MAXON[®]

11921 Slauson Ave. Santa Fe Springs, CA. 90670 (800) 227-4116 FAX (888) 771-7713

CHANGING HYDRAULIC FLUID

CAUTION

Keep dirt, water and other contaminants from entering the hydraulic system. Before opening the hydraulic fluid reservoir filler cap, drain plug and hydraulic lines, clean up contaminants that can get in the openings. Also, protect the openings from accidental contamination. Never mix synthetic fluids with conventional hydraulic fluids. Hydraulic system must be purged if the fluids are mixed.

NOTE: Liftgate is shipped with **Exxon Univis HVI-13** hydraulic fluid in the hydraulic cylinders. **Exxon Univis HVI-13** hydraulic fluid is recommended for operating temperatures of **-40 to +120° F**. Refer to decal in pump box. Under certain conditions, other brands and grades of oil may be used as substitutes for the recommended oil. Refer to **TABLE 14-1**.

1. Unfold and lower platform to the ground (**FIG. 15-1**). Refer to **Operation Manual** for detailed operating instructions.

2. Unbolt and remove cover from main housing as shown in **FIG. 15-1**.

3. Remove drain plug (**FIG. 15-2**). Then, drain hydraulic fluid from reservoir. Reinstall drain plug (**FIG. 15-2**).

4. Remove filler cap (**FIG. 15-2**). Then, add new **Univis HVI-13** hydraulic fluid to level shown in **FIG. 15-2**. Reinstall filler cap.

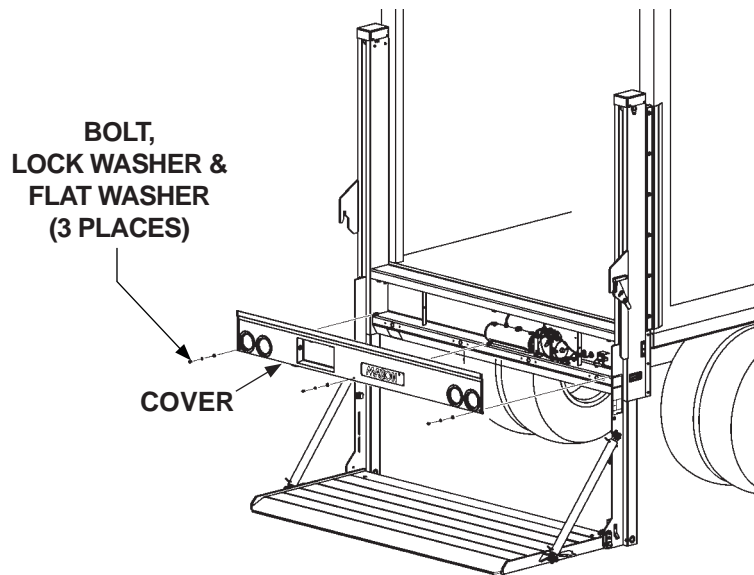

**UNBOLTING COVER
FIG. 15-1**

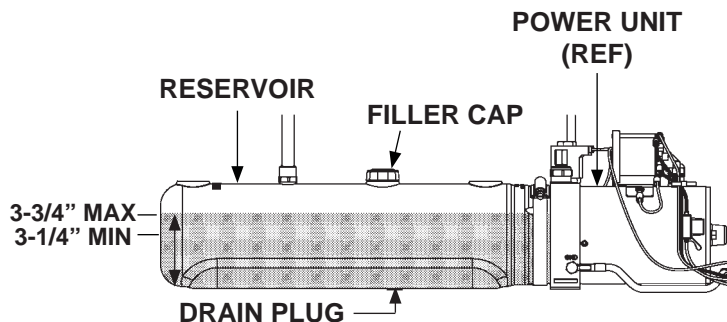

**POWER UNIT FLUID LEVEL
(MANUAL CLOSE POWER UNIT SHOWN)
FIG. 15-2**

PERIODIC MAINTENANCE - Continued

CHANGING HYDRAULIC FLUID - Continued

5. Raise platform to bed height (FIG. 16-1). Continue to hold **UP/DOWN** control switch for 30 - 60 seconds to circulate hydraulic fluid through slave cylinder and reservoir (FIG. 16-2). Release **UP/DOWN** control switch.

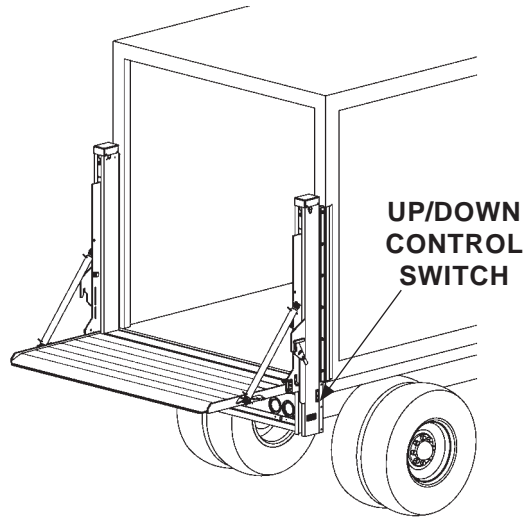

PLATFORM AT BED HEIGHT
FIG. 16-1

NOTE: One cycle of draining, filling, and circulating hydraulic fluid should be enough to fill the system with new hydraulic fluid.

6. Lower platform to the ground (FIG. 16-3).

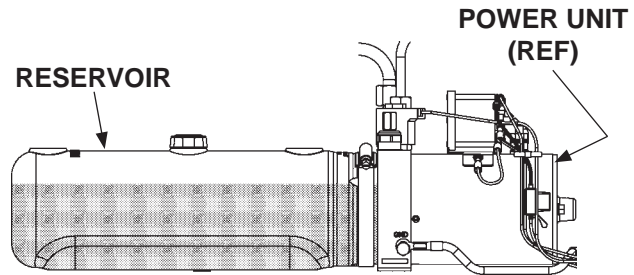

POWER UNIT
(MANUAL CLOSE POWER UNIT SHOWN)
FIG. 16-2

CAUTION
Main housing cover must be correctly secured to prevent it from becoming a hazard.

7. Bolt cover on the main housing as shown in FIG. 16-3. Torque the 5/16"-18 cover bolts from 10 to 14 lb-ft.

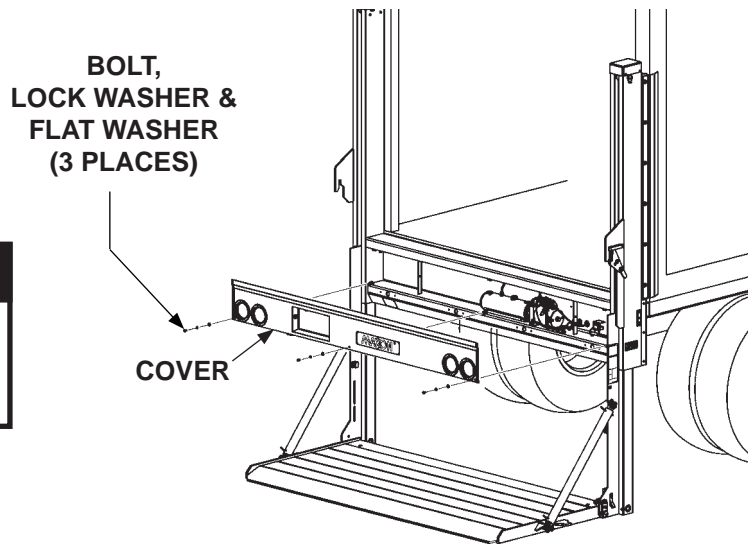

BOLTING ON COVER
FIG. 16-3

TORSION BAR ADJUSTMENT

NOTE: This procedure applies to platforms equipped with manual closer or hydraulic closer. Platforms with manual closer use LH and RH torsion bars to assist with folding and unfolding. Platforms with hydraulic closer use a LH torsion bar to assist hydraulic cylinder with unfolding the platform. A hydraulic cylinder folds the platform. Refer to **TABLE 17-1**.

TORSION BAR ADJUSTMENT		
OBSERVATIONS	PLATFORM WITH MANUAL CLOSER	PLATFORM WITH HYDRAULIC CLOSER
PLATFORM OPENS FULLY WITH LIGHT RESISTANCE	INCREASE TENSION OF RH TORSION BAR	INCREASE TENSION OF LH TORSION BAR
PLATFORM IS DIFFICULT TO CLOSE OR WILL NOT CLOSE	INCREASE TENSION OF LH TORSION BAR	INCREASE TENSION OF LH TORSION BAR

TABLE 17-1

PERIODIC MAINTENANCE - Continued

TORSION BAR ADJUSTMENT - Continued

! WARNING

Ensure platform is latched securely in stowed position to release most tension from torsion bar(s) and keep platform from suddenly unfolding. Injury could result from unbolting the torsion bar(s) under tension. When all tension is released from torsion bar(s), platform can unfold suddenly. Any person in the path of opening platform could be injured.

1. Stow platform (**FIG. 18-1**). Refer to **Operation Manual** for detailed operating instructions.
2. Unbolt and remove torsion bar cover from platform (**FIG. 18-2**).

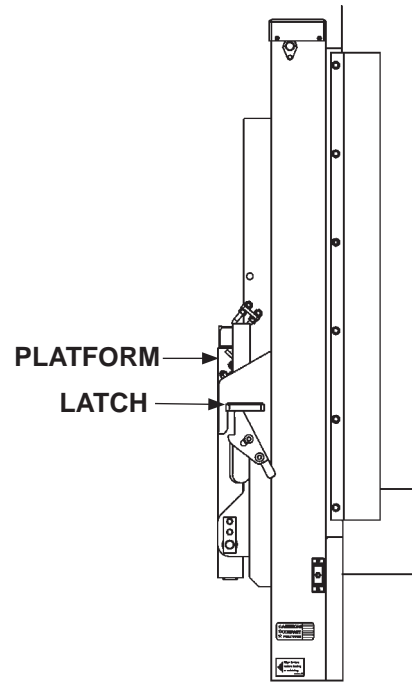

**PLATFORM IN
STOWED POSITION
FIG. 18-1**

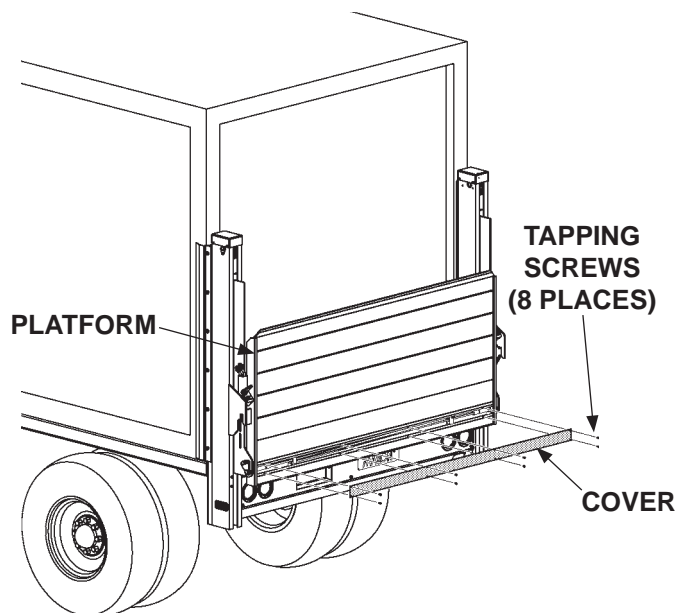

**REMOVING TORSION BAR COVER
FIG. 18-2**

MAXON[®]

11921 Slauson Ave. Santa Fe Springs, CA. 90670 (800) 227-4116 FAX (888) 771-7713

! WARNING

Platform can unfold suddenly with no tension on torsion bar. Stay out of the path of unfolding platform when adjusting the torsion bar. Get second person to help unlatch platform.

ADJUST LH TORSION BAR (ALL PLATFORMS)

1. On the LH runner hold torsion bar pin with a large wrench or gripping pliers to prevent pin from rotating while pin is being unbolted (**FIG. 19-1A**). Next, remove cap screw, lock washer and flat washers from torsion bar pin (**FIG. 19-1**). Keep fasteners to reinstall. Rotate the torsion bar pin counter-clockwise to apply tension to torsion bar (**FIG. 19-1A**). Then, line up the nearest holes on torsion bar pin and runner to bolt pin in that position and keep tension on the torsion bar. Bolt pin to LH runner and tighten securely (**FIG. 19-1**).

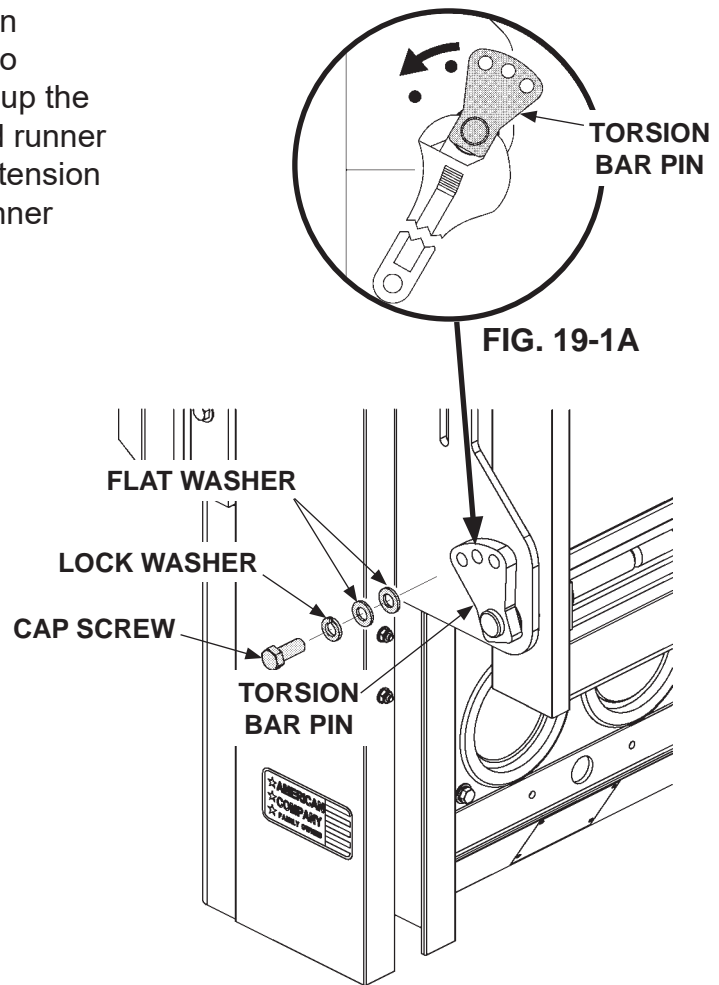

**UNBOLTING PIN FOR LH TORSION BAR
FIG. 19-1**

PERIODIC MAINTENANCE - Continued

TORSION BAR ADJUSTMENT - Continued

2. Lower the platform until arrow decals are lined up on column and runner (**FIG. 19-1**). Refer to **Operation Manual** for detailed operating instructions.
3. If platform is equipped with manual close, unlock the platform. Platform should open as shown in **FIG. 20-1, position 1**. Pull platform to unfold. Observe if platform starts to fold, stays partially unfolded, or starts to fall open with no restraint. Platform should unfold slowly when released (**FIG. 20-1, position 2**). To increase tension on the LH torsion bar, rotate torsion bar pin counter-clockwise until tension increases in LH torsion bar (**FIG. 20-2A**). Once the platform is unfolded, it should lay flat (**FIG. 20-1, position 3**). If platform does not lay flat, decrease tension by removing cap screw, lock washer and flat washers from LH torsion bar pin (**FIG. 20-2**). Rotate torsion bar pin clockwise one hole position (**FIG. 20-2A**). Replace cap screw, lock washer and flat washers (**FIG. 20-2**) and tighten.

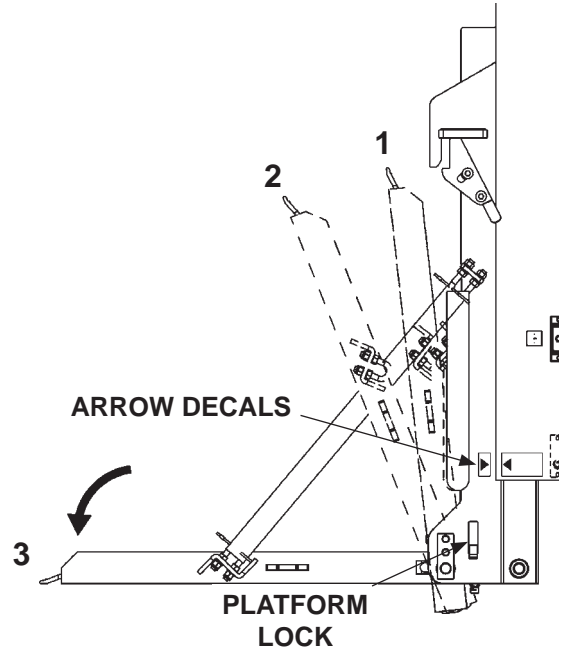

**UNFOLDING PLATFORM
(MANUAL CLOSER SHOWN)
FIG. 20-1**

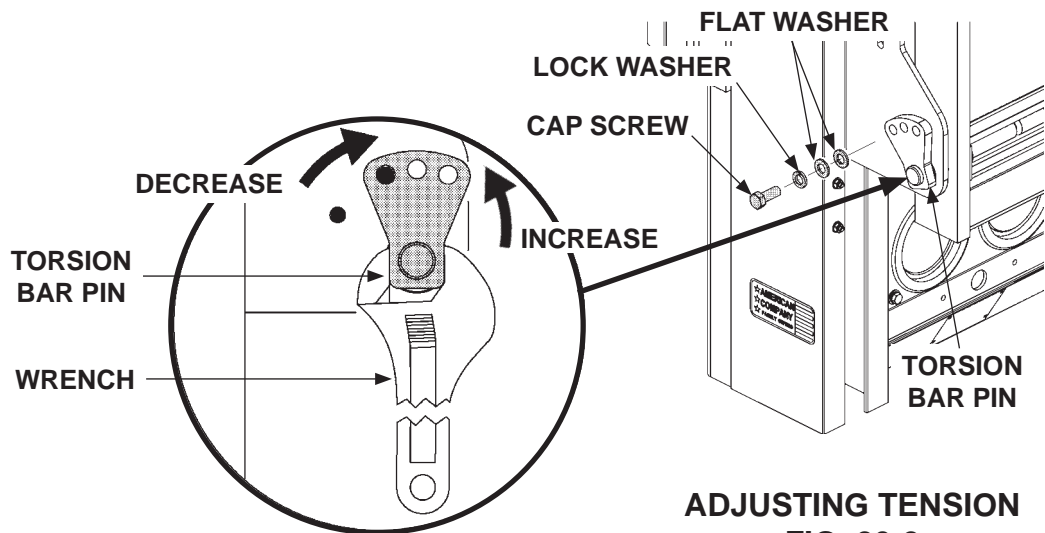
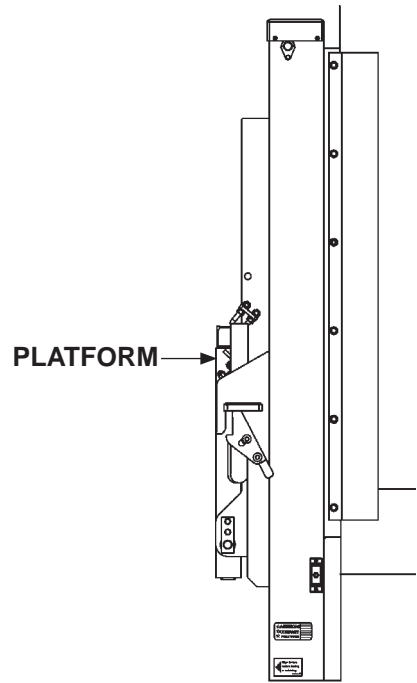

FIG. 20-2A

**ADJUSTING TENSION
FIG. 20-2**

NOTE: Tension can be increased (or decreased) with more precision by changing the position of the LH torsion bar housing.

4. Stow platform (**FIG. 21-1**). Refer to **Operation Manual** for detailed operating instructions.



PLATFORM IN STOWED POSITION
FIG. 21-1

5. To adjust tension on the LH torsion bar, loosen locking screw on housing for LH torsion bar (**FIGS. 21-2 and 20-2A**).

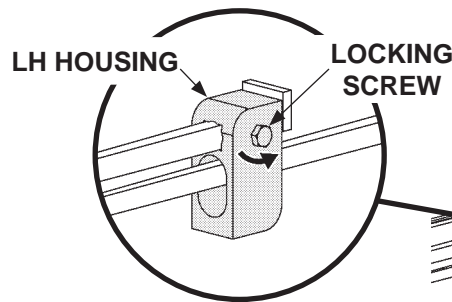

FIG. 21-2A

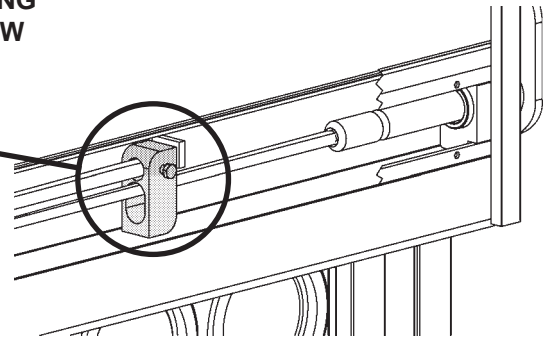
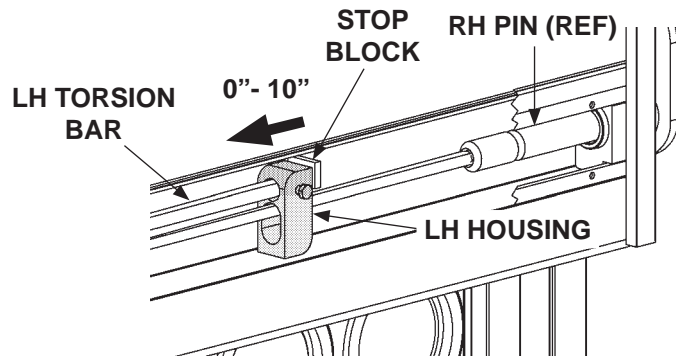

FIG. 21-2

6. Increase tension by sliding LH housing inboard toward LH side of vehicle (**FIG. 21-3**). The range of adjustment is 0" to 10" to the left of stop block (**FIG. 21-3**).



INCREASING TENSION ON LH TORSION BAR
FIG. 21-3

PERIODIC MAINTENANCE - Continued

TORSION BAR ADJUSTMENT - Continued

7. Tighten locking screw securely to hold LH torsion bar housing in position (**FIG. 22-1**).

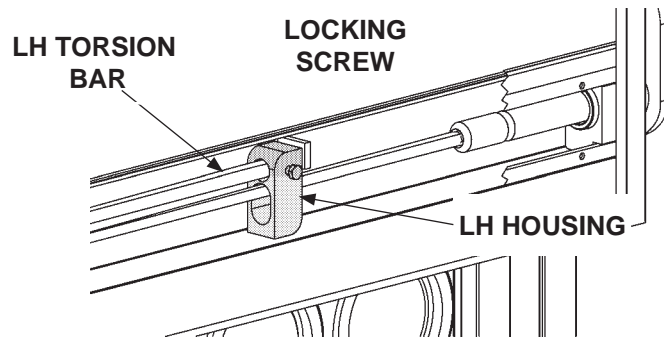

FIG. 22-1

MAXON[®]

11921 Slauson Ave. Santa Fe Springs, CA. 90670 (800) 227-4116 FAX (888) 771-7713

WARNING

Platform can unfold suddenly with no tension on torsion bar. Stay out of the path of unfolding platform when adjusting the torsion bar. Get second person to help unlatch platform.

NOTE: Tension can be increased (or decreased) with more precision by changing the position of the RH torsion bar housing.

ADJUST RH TORSION BAR (PLATFORM WITH MANUAL CLOSE)

1. To adjust tension on the RH torsion bar, loosen locking screw on housing for RH torsion bar (FIGS. 23-1 and 23-1A)

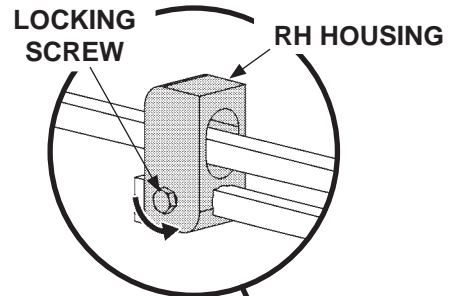

FIG. 23-1A

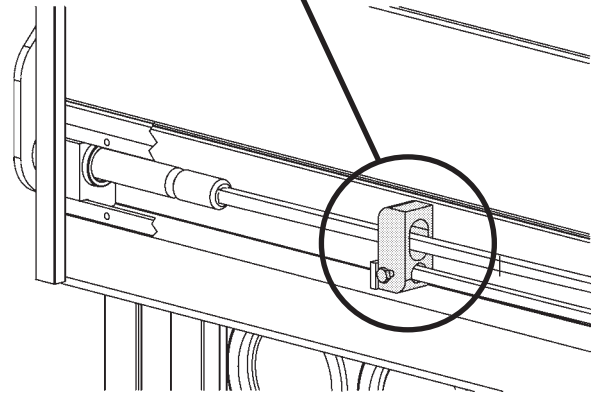
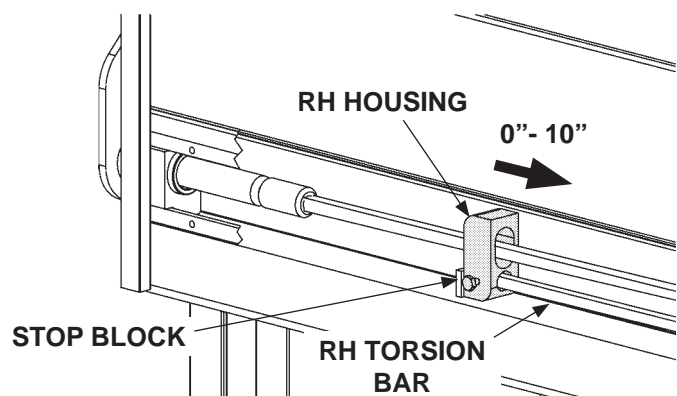

FIG. 23-1

2. Increase tension by sliding RH housing inboard toward RH side of vehicle (FIG. 23-2). The range of adjustment is 0" to 10" to the right of stop block (FIG. 23-2).



INCREASING TENSION ON RH TORSION BAR
FIG. 23-2

PERIODIC MAINTENANCE - Continued

TORSION BAR ADJUSTMENT - Continued

3. Tighten locking screw securely to hold RH torsion bar housing in position (**FIG. 24-1**).

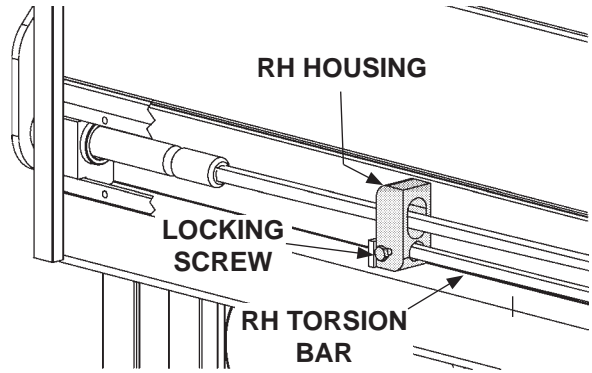
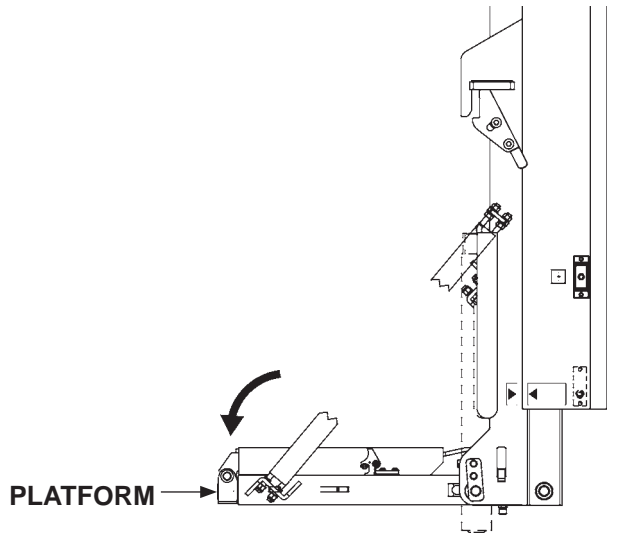
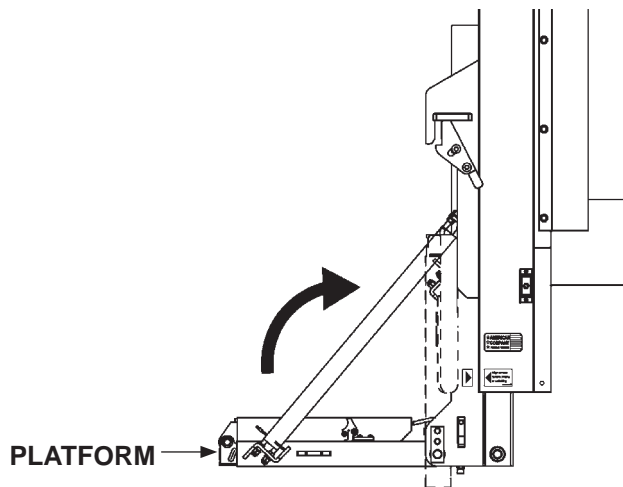

FIG. 24-1

4. Unfold and fold platform (**FIGS. 24-2 and 24-3**). Refer to **Operation Manual** for detailed operating instructions. Ensure platform unfolds and folds correctly. If needed, repeat adjustment procedures for LH and RH torsion bars.



UNFOLDING PLATFORM
FIG. 24-2



FOLDING PLATFORM
FIG. 24-3

MAXON[®]

11921 Slauson Ave. Santa Fe Springs, CA. 90670 (800) 227-4116 FAX (888) 771-7713

5. Reinstall and bolt on torsion bar cover cover (**FIG. 25-1**).

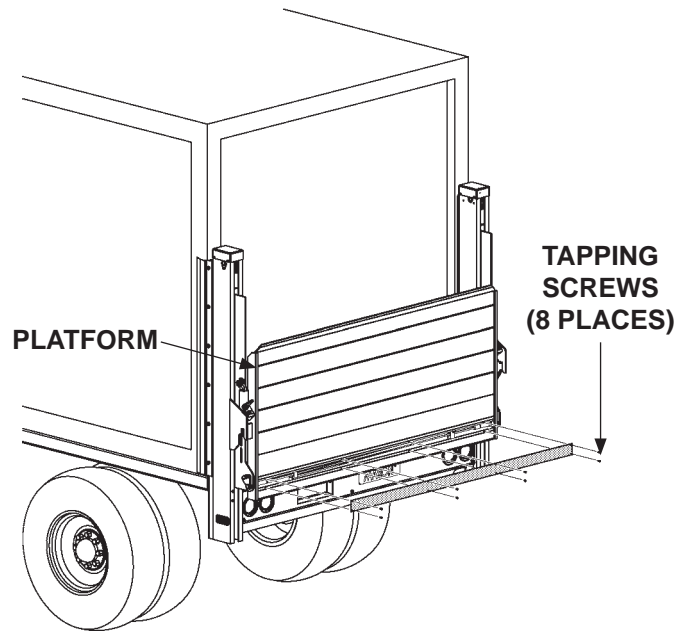

**REATTACH TORSION BAR COVER PLATE
FIG. 25-1**

6. Platform can be stowed or returned to operation after adjustment.

PERIODIC MAINTENANCE - Continued

TORSION BAR ADJUSTMENT - Continued

WARNING

Ensure platform is latched securely in stowed position to release most tension from torsion bar(s) and keep platform from suddenly unfolding. Injury could result from unbolting the torsion bar(s) under tension. When all tension is released from torsion bar(s), platform can unfold suddenly. Any person in the path of opening platform could be injured.

REPLACE LH TORSION BAR

1. Stow platform (**FIG. 26-1**). Refer to **Operation Manual** for detailed operating instructions.
2. Remove torsion bar cover from platform (**FIG. 26-2**).

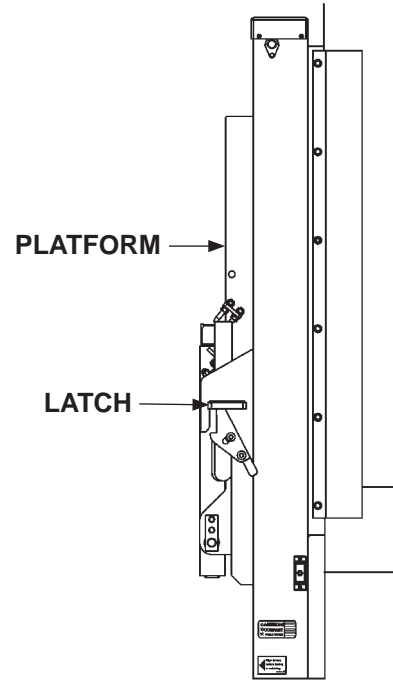
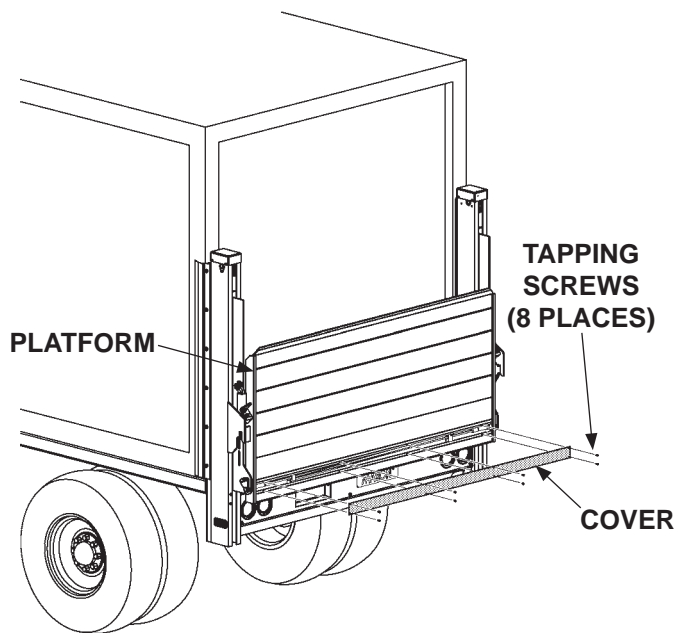

FIG. 26-1



REMOVING TORSION BAR COVER
FIG. 26-2

MAXON[®]

11921 Slauson Ave. Santa Fe Springs, CA. 90670 (800) 227-4116 FAX (888) 771-7713

! WARNING

Platform can unfold suddenly with no tension on torsion bar. Stay out of the path of unfolding platform when adjusting the torsion bar. Get second person to help unlatch platform.

3. Support platform and flipover evenly by attaching chain hoist to the chain u-bolts on the platform, and place supports under the platform (**FIG. 27-1**).

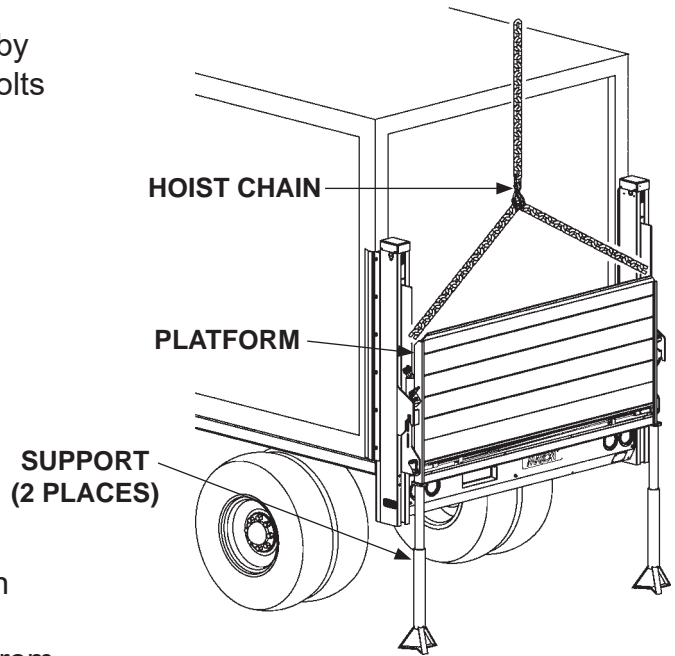

FIG. 27-1

4. On the LH runner, hold torsion bar pin with a large wrench or gripping pliers with clockwise torque to prevent pin from rotating while pin is being unbolted (**FIG. 27-2A**). Remove cap screw and washers from torsion bar pin (**FIG. 27-2**). Initial torsion bar tension is removed when torsion bar pin is in position shown in **FIG. 27-2A**.

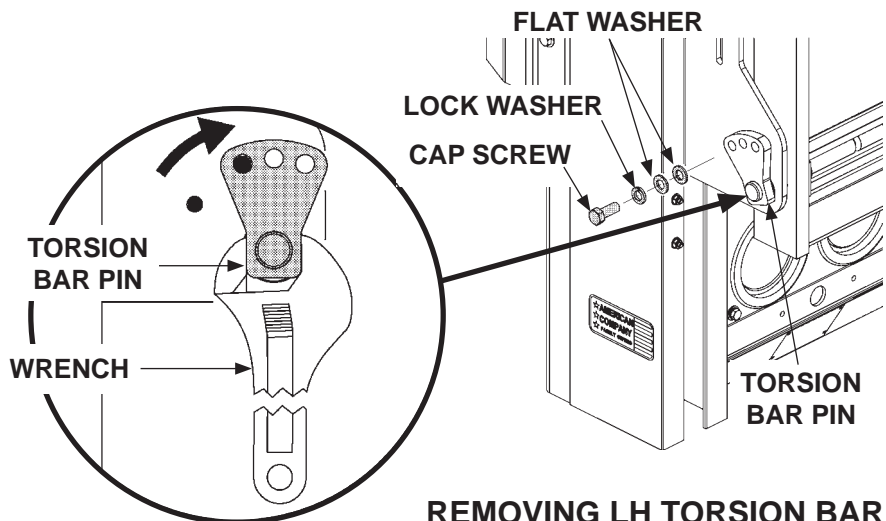

FIG. 27-2A

**REMOVING LH TORSION BAR
INITIAL TENSION
FIG. 27-2**

PERIODIC MAINTENANCE - Continued

TORSION BAR ADJUSTMENT - Continued

5. Remove LH torsion bar pin (FIGS. 28-1 and 28-1A).

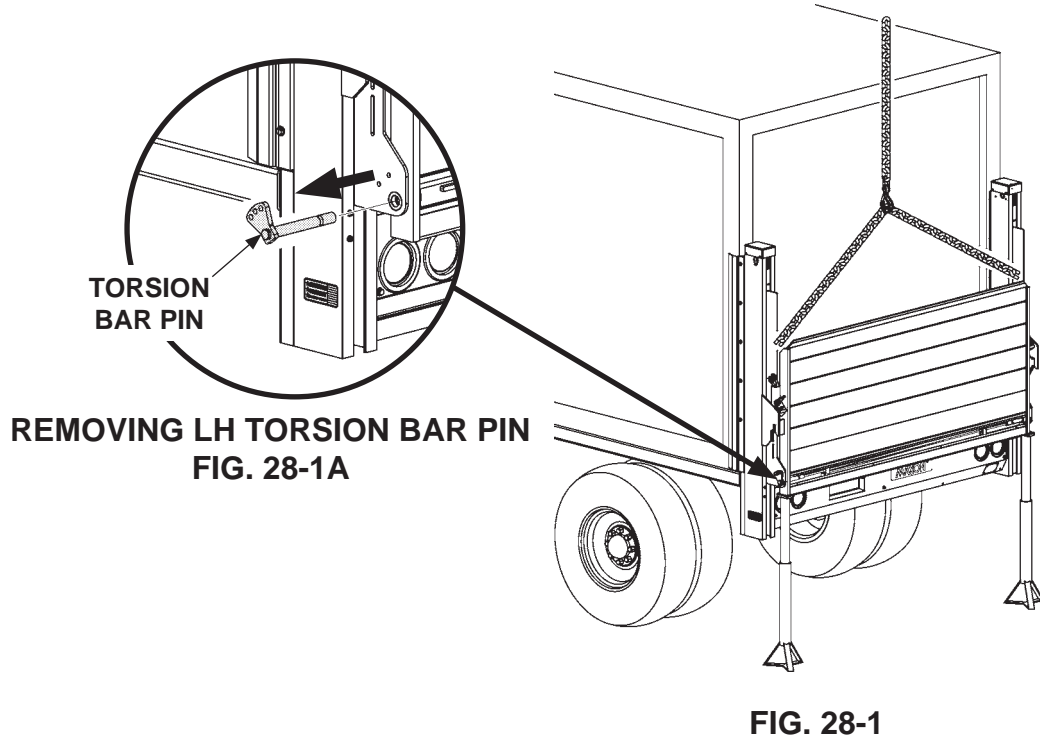

6. Loosen locking screw on LH torsion bar housing (FIGS. 28-2 and 28-2A).

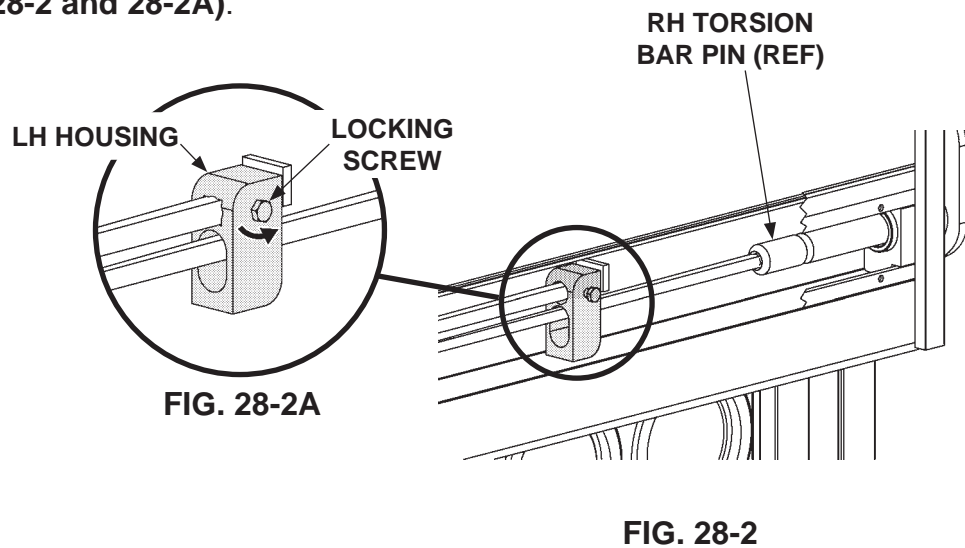

MAXON[®]

11921 Slauson Ave. Santa Fe Springs, CA. 90670 (800) 227-4116 FAX (888) 771-7713

7. Remove LH torsion bar (FIGS. 29-1 and 28-1A).

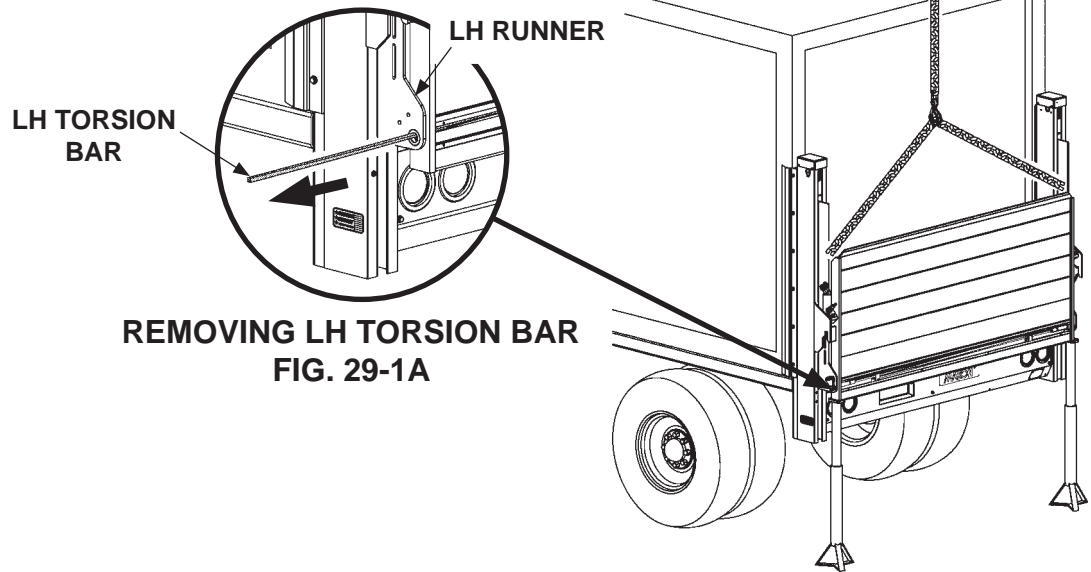

FIG. 29-1

8. With platform in vertical position, insert the replacement torsion bar into the LH platform and runner pin, through LH runner, platform spacer and engage with LH torsion bar housing (FIGS. 29-2 and 29-2A). Tighten locking screw on LH torsion bar housing.

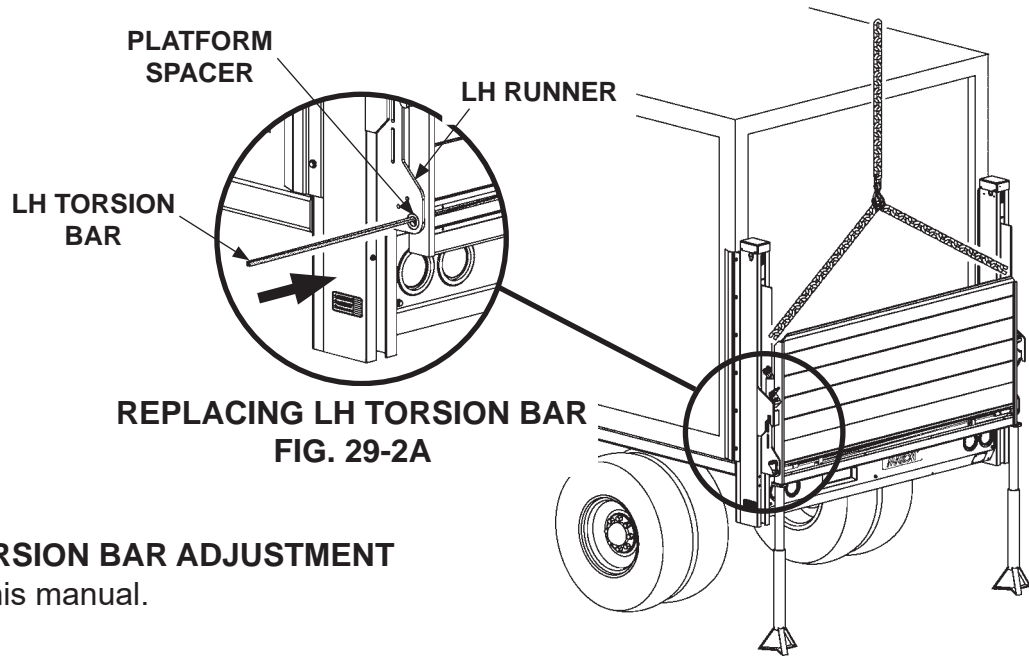

FIG. 29-2

9. Do the LH TORSION BAR ADJUSTMENT procedure in this manual.

PERIODIC MAINTENANCE - Continued

TORSION BAR ADJUSTMENT - Continued

WARNING

Platform can unfold suddenly with no tension on torsion bar. Stay out of the path of unfolding platform when adjusting the torsion bar. Get second person to help unlatch platform.

REPLACE RH TORSION BAR

1. Lower platform to align arrows. Refer to **Operation Manual** for detailed operating instructions. Support platform and flipover evenly by attaching chain hoist to chain u-bolts on the platform, and place supports under the platform (**FIG. 30-1**).

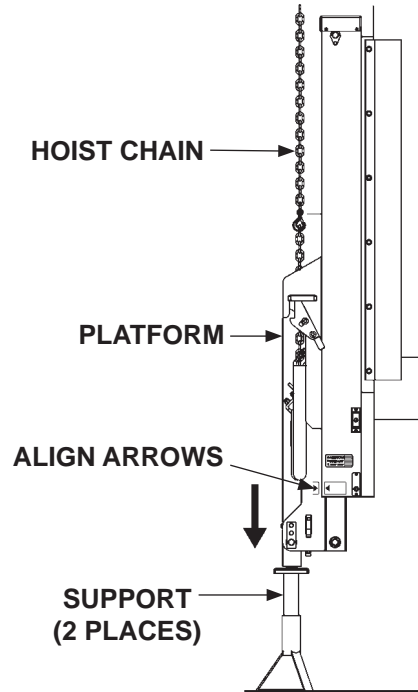

FIG. 30-1

2. Unfold platform approximately 30°-45° (**FIG. 30-2**).

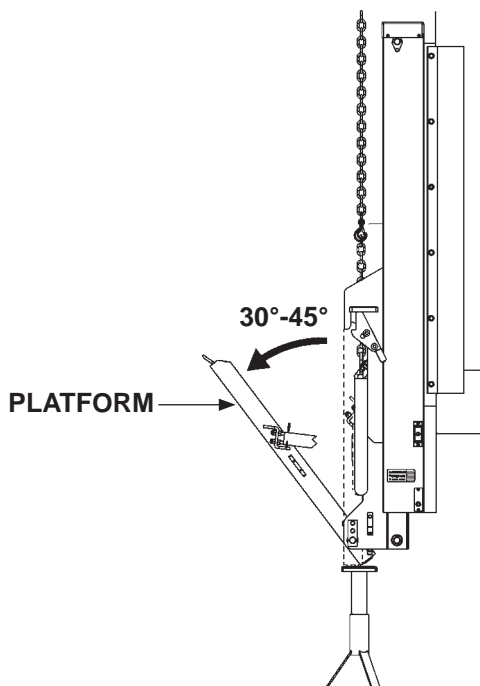
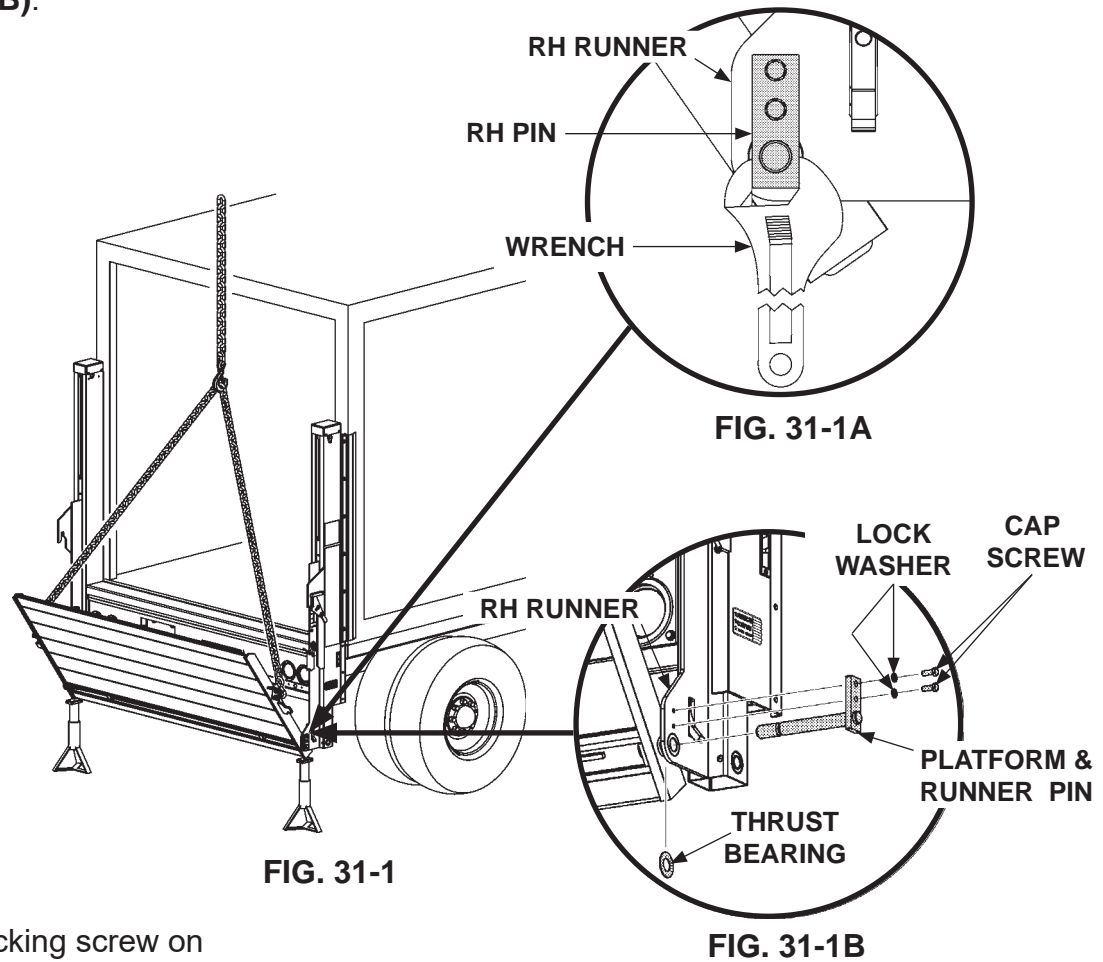

FIG. 30-2

MAXON[®]

11921 Slauson Ave. Santa Fe Springs, CA. 90670 (800) 227-4116 FAX (888) 771-7713

- On RH runner, use large wrench or gripping pliers to hold RH torsion bar pin in vertical position (**FIG. 31-1A**). Unbolt the pin from RH runner (**FIG. 31-1B**). Next, remove platform pin, and thrust bearing (**FIG. 31-1B**).



- Loosen locking screw on RH torsion bar housing (**FIGS. 31-2 and 31-2A**).

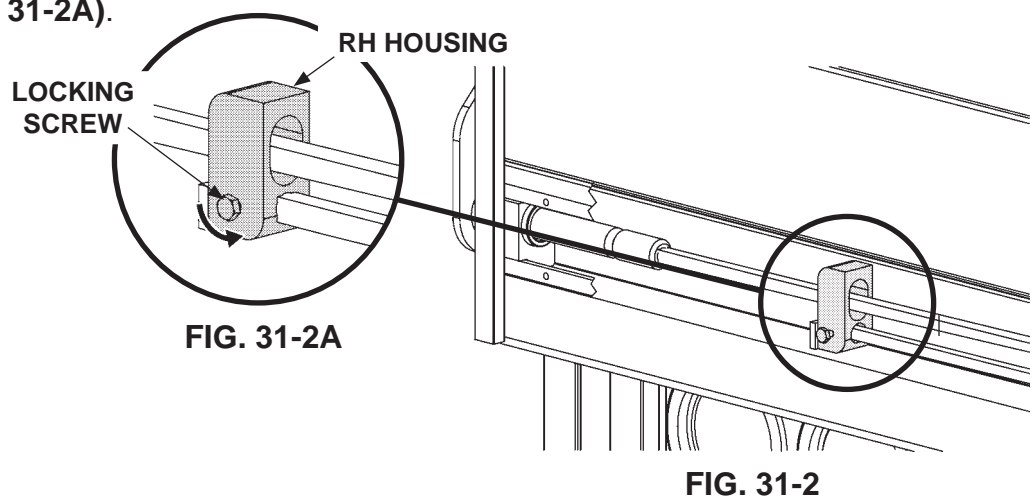

PERIODIC MAINTENANCE - Continued

TORSION BAR ADJUSTMENT - Continued

5. Remove RH torsion bar (FIGS. 32-1 and 32-1A).

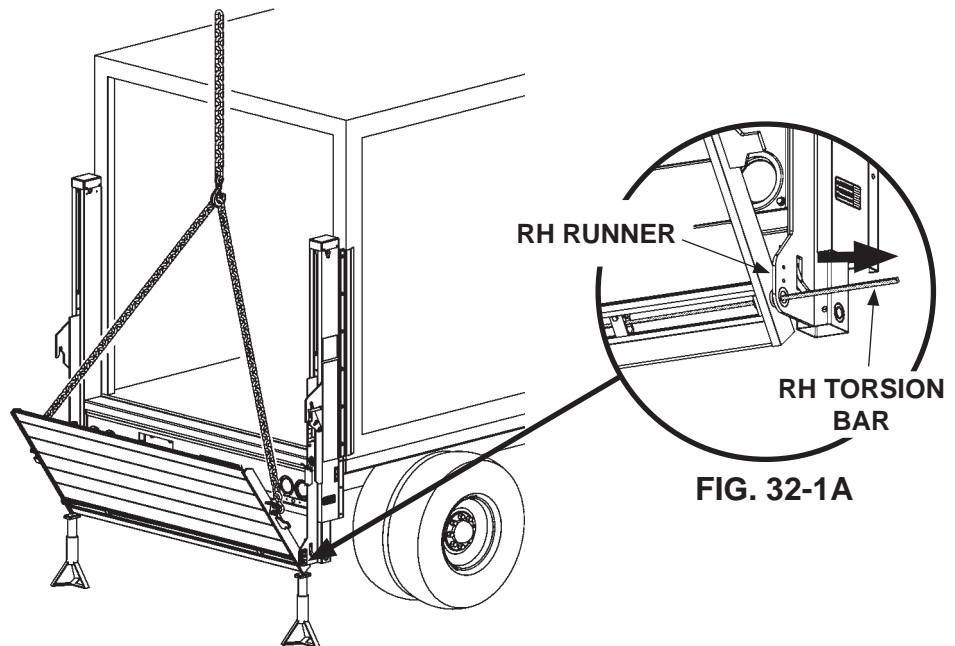

REMOVING RH TORSION BAR
FIG. 32-1

6. Insert the replacement torsion bar through RH runner, thrust bearing, and RH torsion bar housing (FIGS. 32-2 and 32-2A).

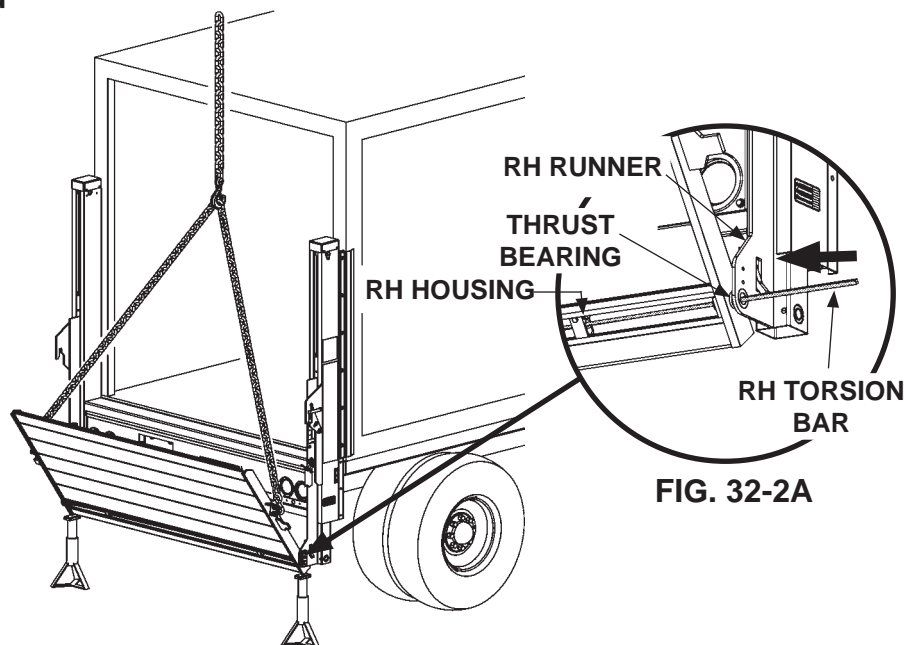

REPLACING RH TORSION BAR
FIG. 32-2

MAXON[®]

11921 Slauson Ave. Santa Fe Springs, CA. 90670 (800) 227-4116 FAX (888) 771-7713

7. Insert the RH torsion bar pin. Use a large wrench to rotate the RH pin counterclockwise to line up the pin holes with the threaded holes in the RH runner (**FIGS. 33-1 and 33-1A**). Next, bolt RH pin to RH runner using cap screws and washers removed in step 3.

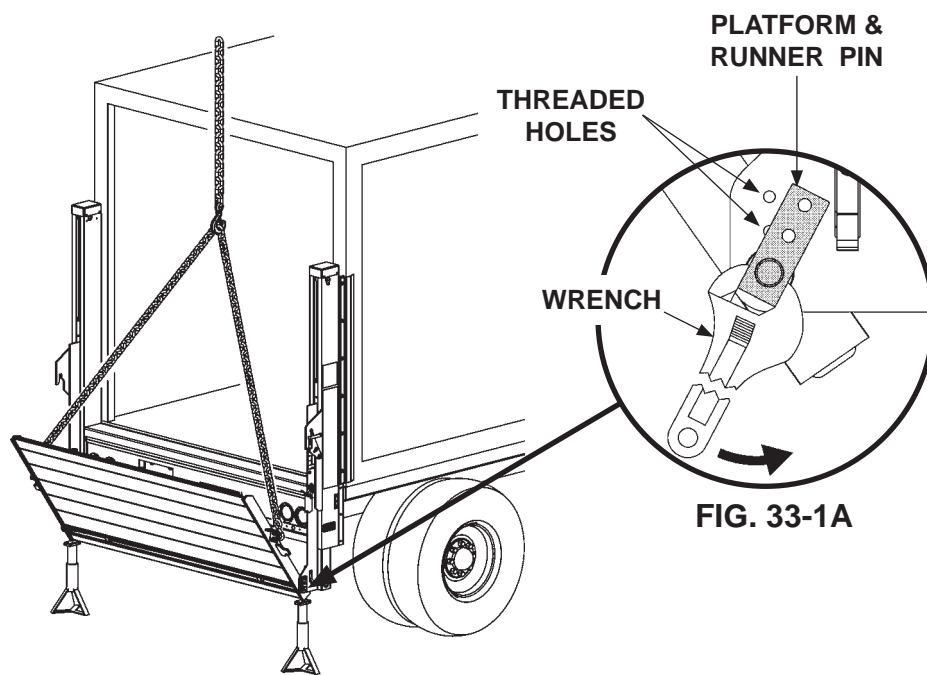

REPLACING PLATFORM & RUNNER PIN
FIG. 33-1

8. Do the **RH TORSION BAR ADJUSTMENT** procedure in this manual.

MEASURE & ADJUST CLEARANCE FOR PLATFORM WITH FLIPOVER

NOTE: This procedure only applies to platforms equipped with a flipover section. The platform and flipover must be in the stowed position to accurately measure clearance between main housing and bottom of flipover. The platform and flipover may be lowered below bed height in stowed position for better access to measure clearance.

1. Gain access to main housing and bottom of flipover section to measure clearance (**FIG. 34-1**). Refer to **DMD Operation Manual** for instructions to lower platform until arrow decals are aligned. Ensure platform is kept folded (stowed).

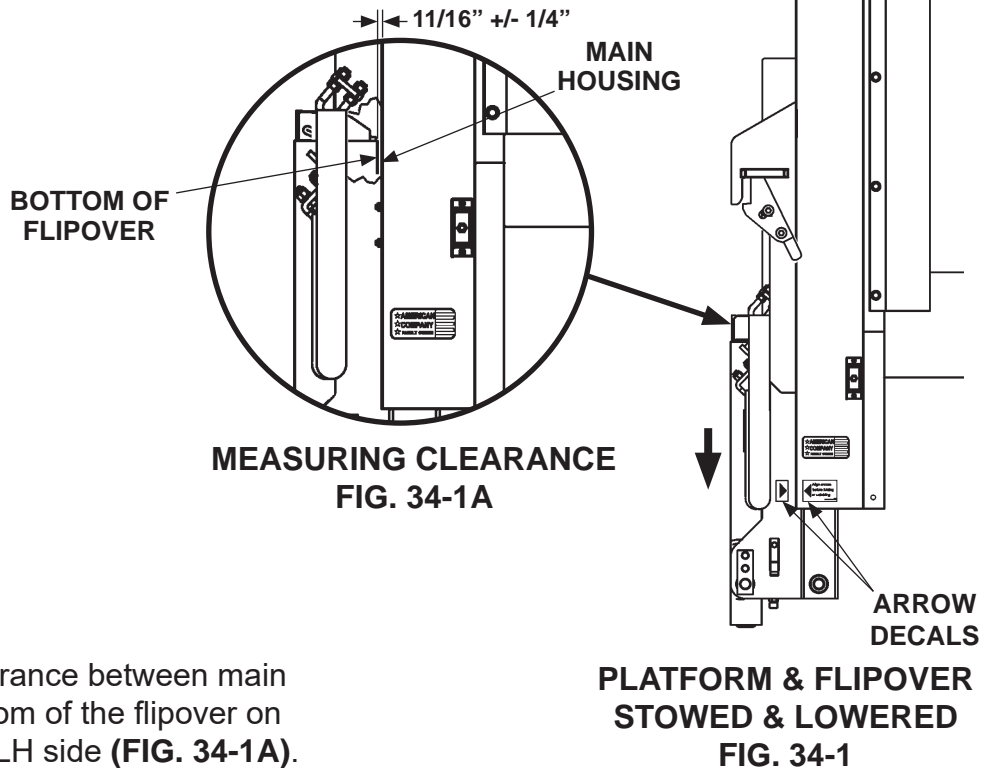

2. Measure the clearance between main housing and bottom of the flipover on the RH side and LH side (**FIG. 34-1A**). Clearance should be $11/16'' \pm 1/4''$ on both sides of the housing and flipover. No adjustment is required with this clearance. When clearance is incorrect, on the LH and/or RD sides adjust the clearance starting with with step 3.

MAXON[®]

11921 Slauson Ave. Santa Fe Springs, CA. 90670 (800) 227-4116 FAX (888) 771-7713

3. Unfold plattform to gain access to the plastic platform stops on the LH and RH runners (**FIG. 35-1**).

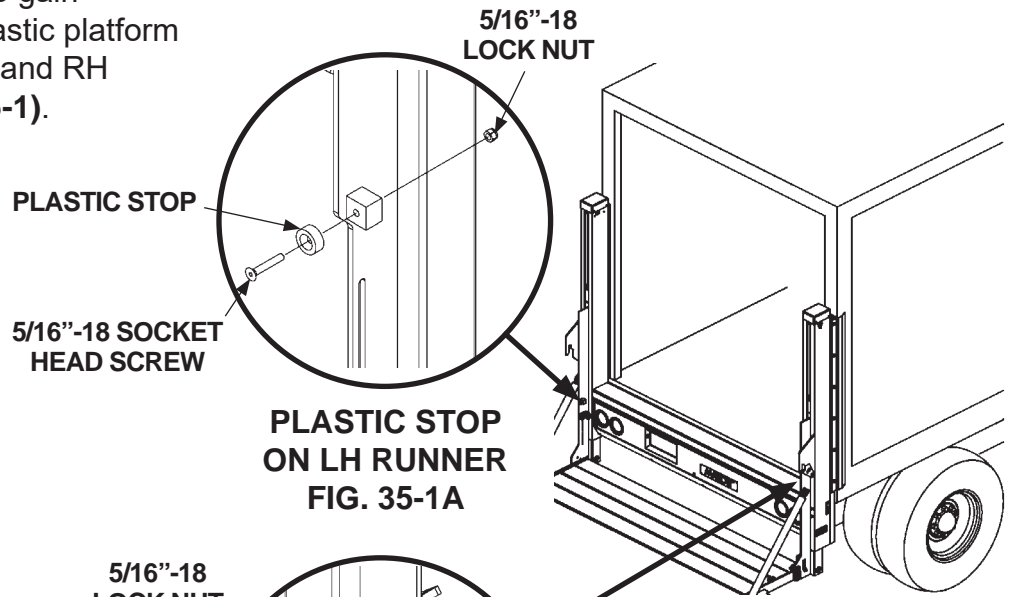

**PLASTIC STOP ON LH RUNNER
FIG. 35-1A**

4. Remove plastic stop from LH and/or RH runner (**FIGS. 35-1A and 35-1B**).

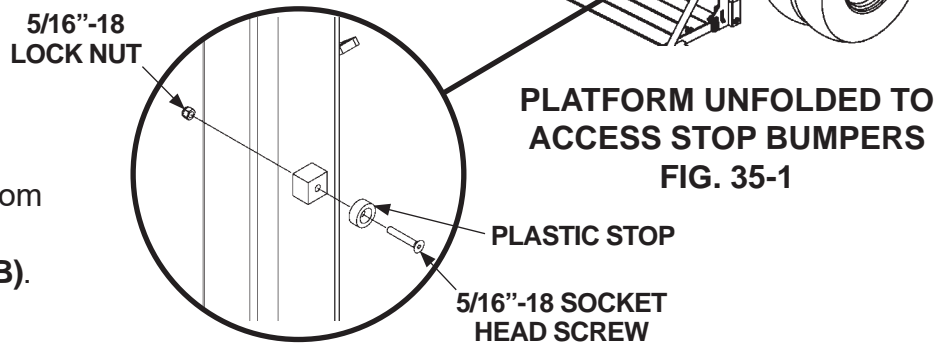

**PLASTIC STOP ON RH RUNNER
FIG. 35-1B**

5. Calculate the minimum thickness of shim washers needed to increase clearance to $11/16'' \pm 1/4''$ between main housing and bottom of flipover. For example, if minimum clearance should be $7/16''$ and the measured clearance is only $3/8''$ ($7/16'' - 6/16'' = 1/16''$), a $1/16''$ thick washer will restore the minimum clearance shown in step 2.

MEASURE & ADJUST CLEARANCE FOR PLATFORM WITH FLIPOVER - Continued

NOTE: MAXON does not supply the fender washers to shim the stops.

- Reinstall plastic stop bumper with 1 or more 1/16" thick fender washers, for 5/16" screws, to shim the plastic stops (**FIGS. 36-1A and 36-1B**). This will adjust the clearance between main housing and bottom of flipover as necessary on the LH and/or RH side of the platform.

- Refer to **DMD Operation Manual** for instructions to fold platform.

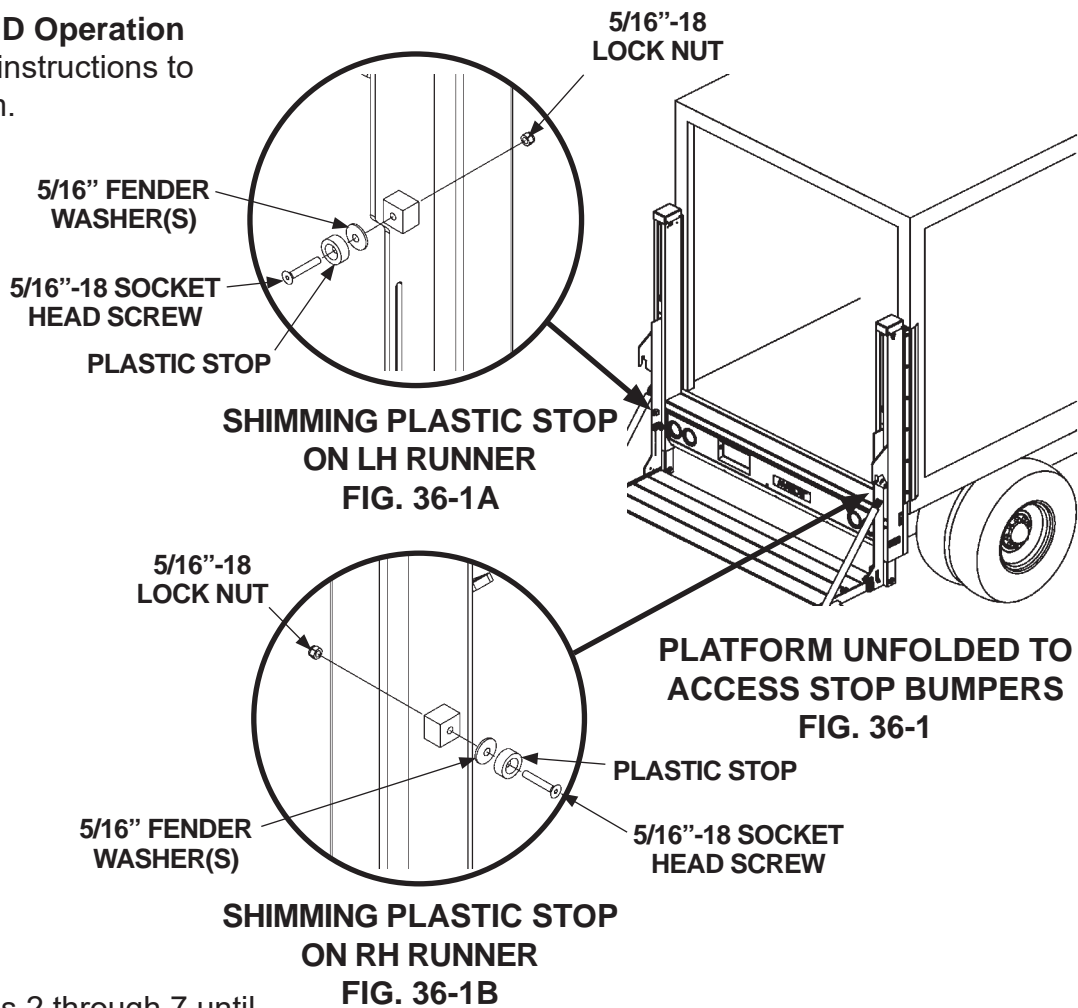

- Repeat steps 2 through 7 until clearance is 11/16" +/- 1/4" between the main housing and bottom of the flipover.
- When adjustment is done correctly, refer to **DMD Operation Manual** for instructions to stow the platform or use the Liftgate to load and unload vehicle.

MAXON[®]

11921 Slauson Ave. Santa Fe Springs, CA. 90670 (800) 227-4116 FAX (888) 771-7713

DECALS

NOTE: Decals are preinstalled at factory.
Decal location shown for reference.

NOTE: Ensure there is no residue, dirt or corrosion where decals are attached.
If necessary, clean surface before replacing decals.

WARNING
Liftgate hazards can result in crushing or falling.
Keep hands and feet clear of pinch points.
If riding liftgate, make sure load is stable and footing is solid.

Advertencia
Existe riesgo de caer desde o ser prensado por el elevador.
Mantenga manos y pies fuera de las zonas de plegue.
Asegúrese de tener la carga estable y usted parado firmemente sobre el elevador.



Read and understand all instructions and warnings before use.
Lea y comprenda todos los instrucciones y advertencias previa operación.

WARNING DECAL
P/N 299274-01

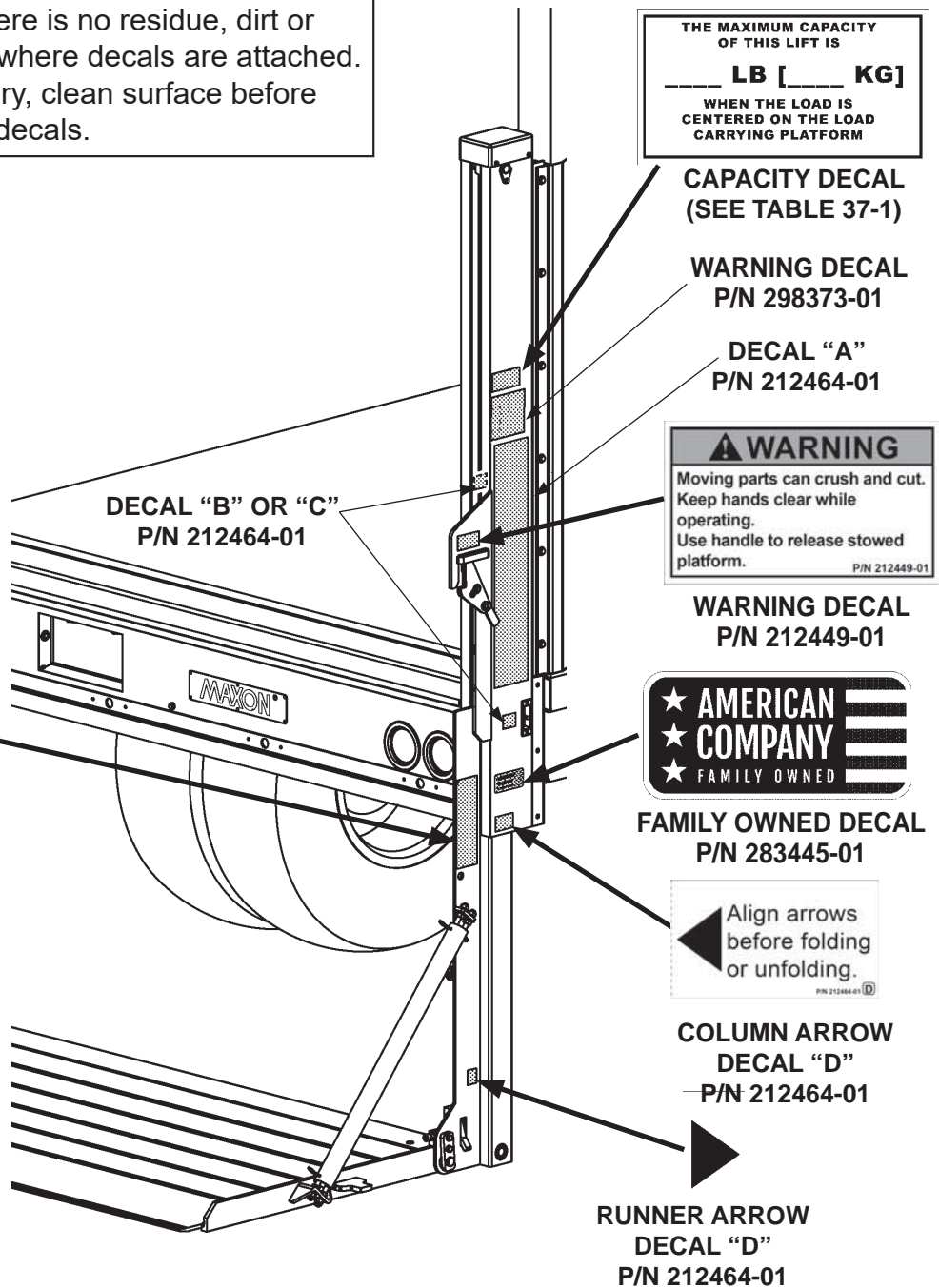

MODEL	ORDER P/N	CAPACITY DECAL
DMD-18	220387-04	1800 LB [817 KG]
DMD-22	220388-03	2200 LB [1000 KG]
DMD-33	220388-02	3300 LB [1500 KG]

DECAL SHEET PART NUMBERS
TABLE 37-1

DECALS - DMD WITH DOCK BUMPERS

NOTE: Decals are preinstalled at factory.
Decal location shown for reference.

NOTE: Ensure there is no residue, dirt or corrosion where decals are attached.
If necessary, clean surface before replacing decals.

MAXON[®]

11921 Slauson Ave. Santa Fe Springs, CA. 90670 (800) 227-4116 FAX (888) 771-7713

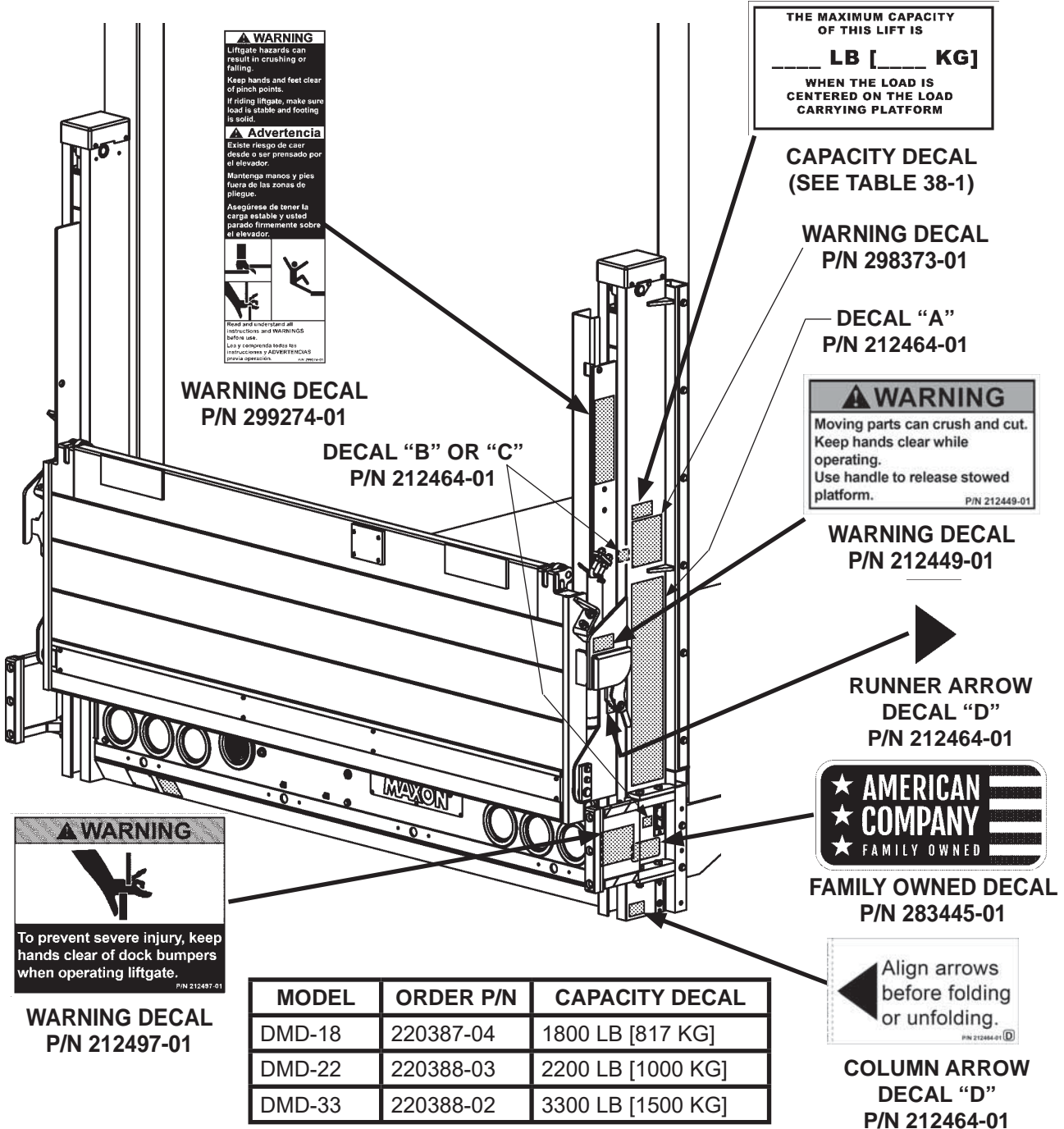

⚠ WARNING
Liftgate hazards can result in crushing or falling.
Keep hands and feet clear of pinch points.
If riding liftgate, make sure load is stable and footing is solid.

⚠ Advertencia
Existe riesgo de caer desde o ser prensado por el elevador.
Mantenga manos y pies fuera de las zonas de pliegue.
Asegúrese de tener la carga estable y usted parado firmemente sobre el elevador.

Read and understand all instructions and warnings before use.
Lea y comprenda todas las instrucciones y advertencias previa operación.

THE MAXIMUM CAPACITY OF THIS LIFT IS
___ LB [___ KG]
WHEN THE LOAD IS CENTERED ON THE LOAD CARRYING PLATFORM

CAPACITY DECAL (SEE TABLE 38-1)

WARNING DECAL P/N 298373-01

DECAL "A" P/N 212464-01

⚠ WARNING
Moving parts can crush and cut. Keep hands clear while operating. Use handle to release stowed platform.
P/N 212449-01

WARNING DECAL P/N 212449-01

RUNNER ARROW DECAL "D" P/N 212464-01



FAMILY OWNED DECAL P/N 283445-01

⚠ WARNING
To prevent severe injury, keep hands clear of dock bumpers when operating liftgate.
P/N 212497-01

WARNING DECAL P/N 212497-01

MODEL	ORDER P/N	CAPACITY DECAL
DMD-18	220387-04	1800 LB [817 KG]
DMD-22	220388-03	2200 LB [1000 KG]
DMD-33	220388-02	3300 LB [1500 KG]

Align arrows before folding or unfolding.
P/N 212464-01 (D)

COLUMN ARROW DECAL "D" P/N 212464-01

DECAL SHEET PART NUMBERS TABLE 38-1

CAUTION
Always stand clear of platform area.



Read and understand all instructions and WARNINGS before use.

WARNING
Read this information carefully.

- Improper operation of this Liftgate can result in serious personal injury. If you do not have a copy of the operating instructions, please obtain them from your employer, distributor, or lessor before you attempt to operate Liftgate.
- If there are signs of improper maintenance, damage to vital parts, or slippery platform surface, do not use the Liftgate until these problems have been corrected.
- If you are using a pallet jack, be sure it can be maneuvered safely.
- Do not operate it on the platform.
- Do not allow any part of yours or your helper's body to be placed under, within, or around any portion of the moving Liftgate, or its mechanisms, or at a position that would trap them between the platform and the ground or truck when the Liftgate is operated.
- If a helper is riding the platform with you, make sure you are both doing so safely and that you are not in danger of coming in contact with any moving or potentially moving components.
- USE GOOD COMMON SENSE.
- If load appears to be unsafe, do not lift or lower it.

For a free copy of other manuals that pertain to the Model Liftgate, please visit our website at www.maxonlift.com or call Customer Service at (800) 227-4116.

OPERATING INSTRUCTIONS

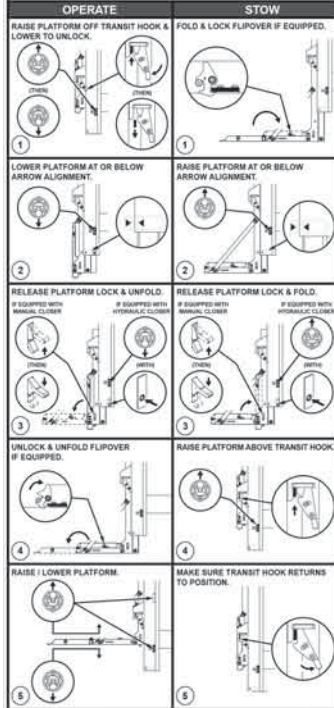
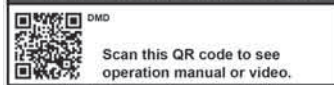

SAFETY INSTRUCTIONS
Rotate handle to release stowed platform.

SAFETY INSTRUCTIONS

- Read all decals and operation manual before operating liftgate.
- Do not use liftgate unless you have been properly instructed and have read, and are familiar with, the operating instructions.
 - Be certain vehicle is properly and securely braked before using the liftgate.
 - Always inspect this liftgate for maintenance or damage before using it. Do not use liftgate if it shows any sign of damage or improper maintenance.
 - Do not overload.
 - Make certain the area in which the platform will open and close is clear before opening or closing the platform.
 - Make certain platform area, including the area in which loads may fall from platform, is clear before and at all times during operation of liftgate.
 - This liftgate is intended for loading and unloading of cargo only. Do not use this liftgate for anything but its intended use.

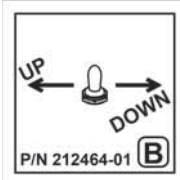

DECAL SHEET
P/N 212464-01

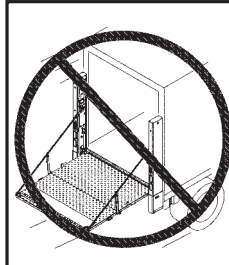

WARNING
A Liftgate extending from a moving vehicle could injure bystanders & damage property. Stow liftgate in correct transit position before moving vehicle.

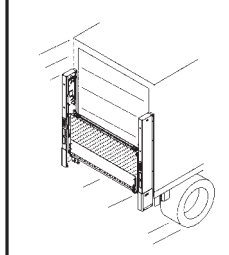

Advertencia
Un elevador hidráulico abierto en vehículo en movimiento puede ocasionar daños y lesiones a objetos y personas circundantes. Cierre apropiadamente antes de poner el vehículo en movimiento.

P/N 298373-01

WARNING DECAL
P/N 298373-01

WARNING
Liftgate hazards can result in crushing or falling.

Keep hands and feet clear of pinch points.
If riding liftgate, make sure load is stable and footing is solid.

Advertencia
Existe riesgo de caer desde o ser prensado por el elevador.
Mantenga manos y pies fuera de las zonas de pliegue.
Asegúrese de tener la carga estable y usted parado firmemente sobre el elevador.



Read and understand all instructions and WARNINGS before use.
Lea y comprenda todas las instrucciones y ADVERTENCIAS previa operación.

PN 299274-01

WARNING DECAL
P/N 299274-01

MAXON 11921 Slauson Ave. Santa Fe Springs, CA. 90670 (800) 227-4116 FAX (888) 771-7713

DECALS & PLATES

NOTE: Preferred decal layout is shown. Decals on the Liftgate are attached at the factory, except for the 24/7 SUPPORT decal. The 24/7 SUPPORT decal is placed at customer's or installer's preference.

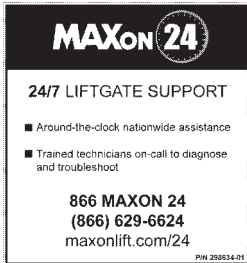

**MAXON 24/7
SUPPORT DECAL
P/N 298634-01**



**MAXON NAME PLATE
P/N 050175**

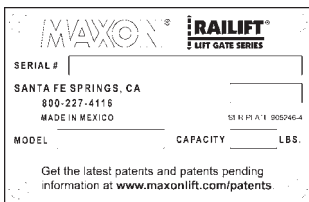

**SERIAL PLATE
(REF)**



**PARTS QR CODE
DECAL
P/N 299143-01**

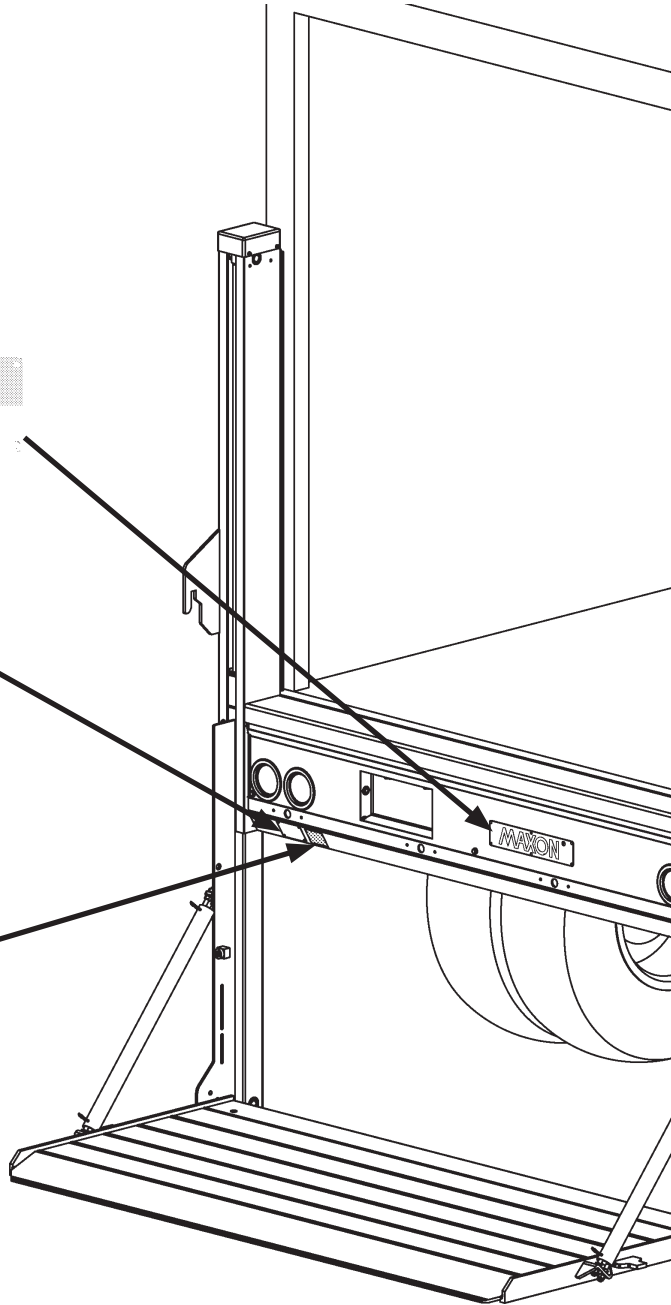

FIG. 40-1

MAXON

11921 Slauson Ave. Santa Fe Springs, CA. 90670 (800) 227-4116 FAX (888) 771-7713

DECALS AND PLATES- DMD WITH DOCK BUMPERS

NOTE: Preferred decal layout is shown. Decals on the Liftgate are attached at the factory, except for the 24/7 SUPPORT decal. The 24/7 SUPPORT decal is placed at customer's or installer's preference.

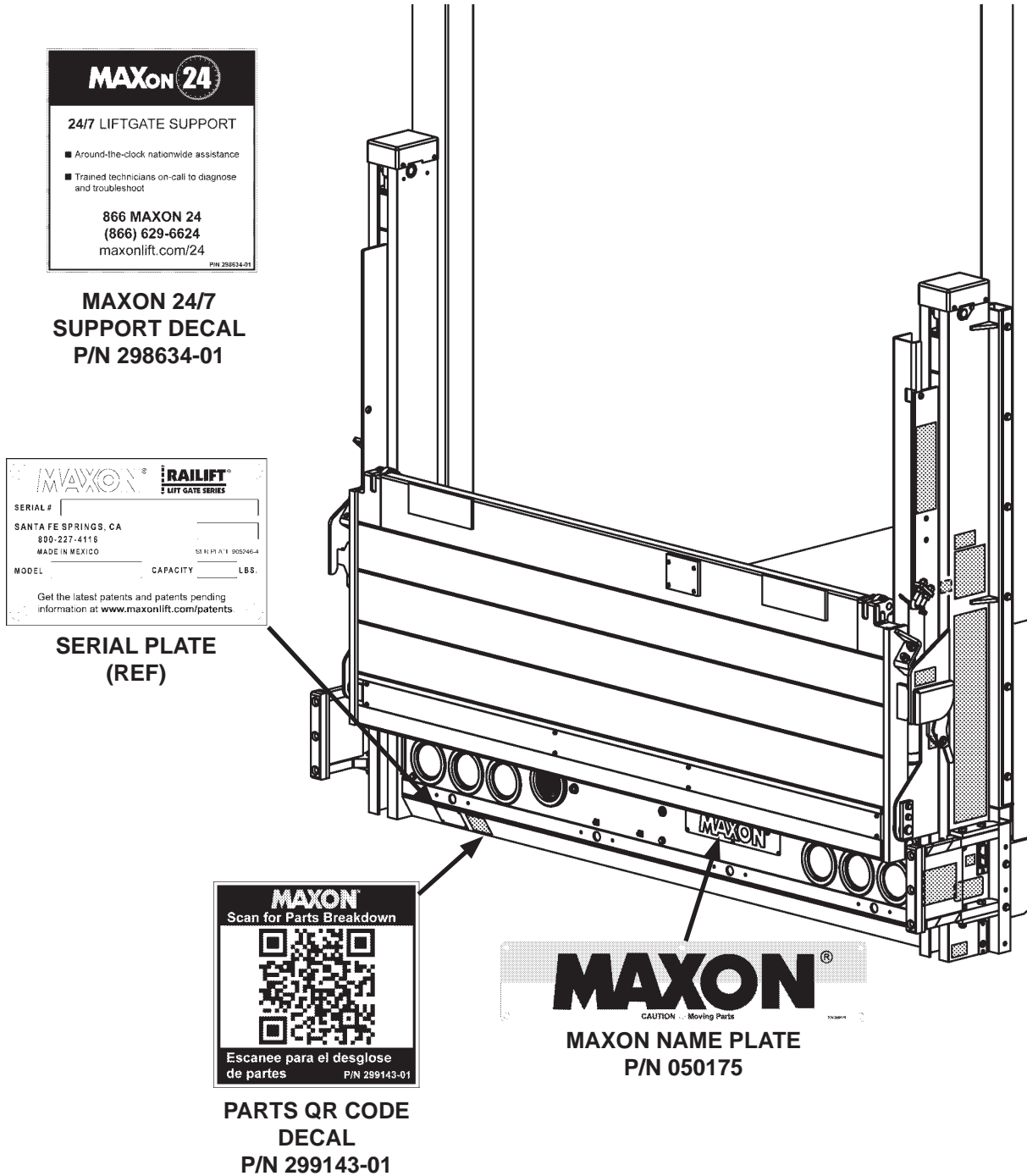

MAXON 24

24/7 LIFTGATE SUPPORT

- Around-the-clock nationwide assistance
- Trained technicians on-call to diagnose and troubleshoot

866 MAXON 24
(866) 629-6624
maxonlift.com/24

P/N 298634-01

**MAXON 24/7
SUPPORT DECAL
P/N 298634-01**

MAXON **RAILIFT**
LIFT GATE SERIES

SERIAL # _____
SANTA FE SPRINGS, CA _____
800-227-4116 _____
MADE IN MEXICO SERIAL # 905246-4 _____
MODEL _____ CAPACITY _____ LBS. _____

Get the latest patents and patents pending information at www.maxonlift.com/patents

**SERIAL PLATE
(REF)**

MAXON
Scan for Parts Breakdown

Escanee para el desglose de partes P/N 299143-01

**PARTS QR CODE
DECAL
P/N 299143-01**

MAXON[®]
CAUTION ... Moving Parts

**MAXON NAME PLATE
P/N 050175**

FIG. 41-1

MAXON[®] 11921 Slauson Ave. Santa Fe Springs, CA. 90670 (800) 227-4116 FAX (888) 771-7713

SYSTEM DIAGRAMS

PUMP MOTOR & VALVE OPERATION (MANUAL CLOSE)

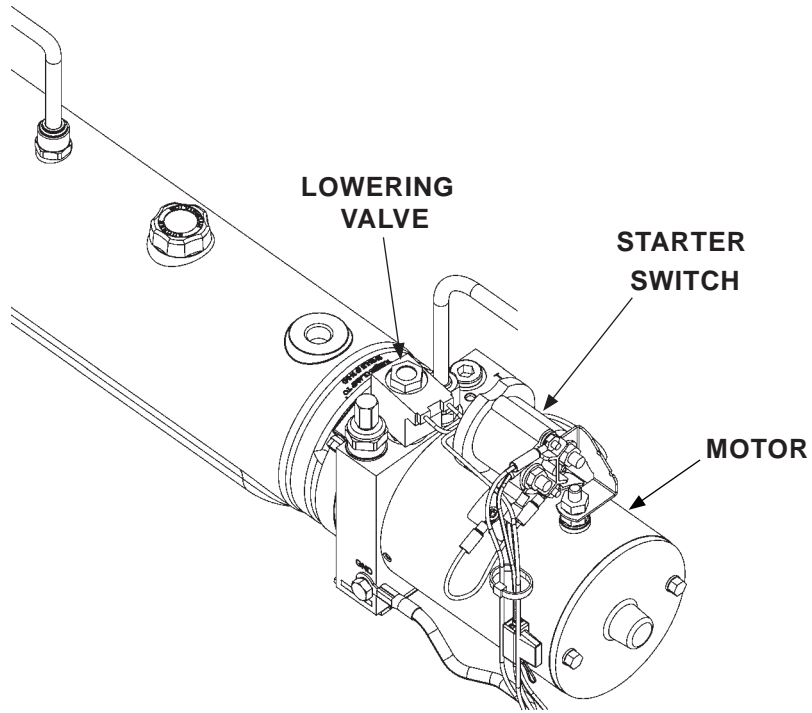

**POWER UNIT
FIG. 42-1**

POWER UNIT MOTOR & SOLENOID OPERATION		
LIFTGATE FUNCTION	SOLENOID OPERATION (✓ MEANS ENERGIZED)	
	MOTOR STARTER SWITCH	LOWERING VALVE
RAISE	✓	-
LOWER	-	✓
REFER TO VALVES SHOWN ON HYDRAULIC SCHEMATIC		

TABLE 42-1

PUMP MOTOR & VALVE OPERATION (EQUIPPED WITH HYDRAULIC CLOSER)

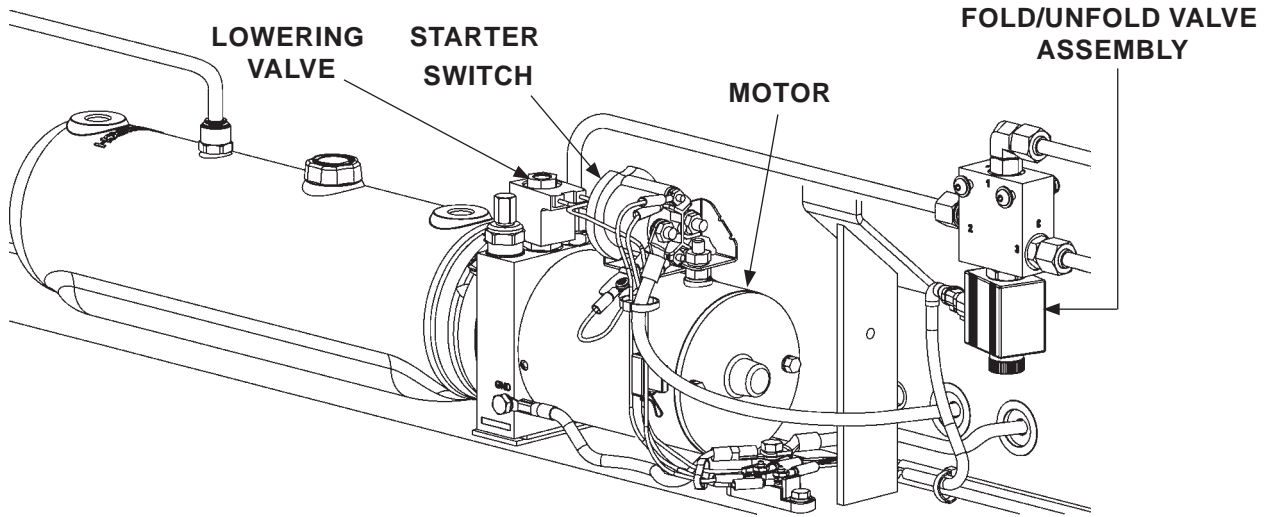

**POWER UNIT
FIG. 43-1**

POWER UNIT MOTOR & VALVE OPERATION			
LIFTGATE FUNCTION	REMOTE VALVE OPERATION (✓ MEANS ENERGIZED)		
	MOTOR	LOWERING VALVE	FOLD/UNFOLD VALVE
RAISE	✓		
LOWER		✓	
UNFOLD		✓	✓
FOLD	✓		✓
REFER TO VALVES SHOWN ON HYDRAULIC SCHEMATIC			

TABLE 43-1

SYSTEM DIAGRAMS - Continued

HYDRAULIC SCHEMATIC (MANUAL CLOSE)

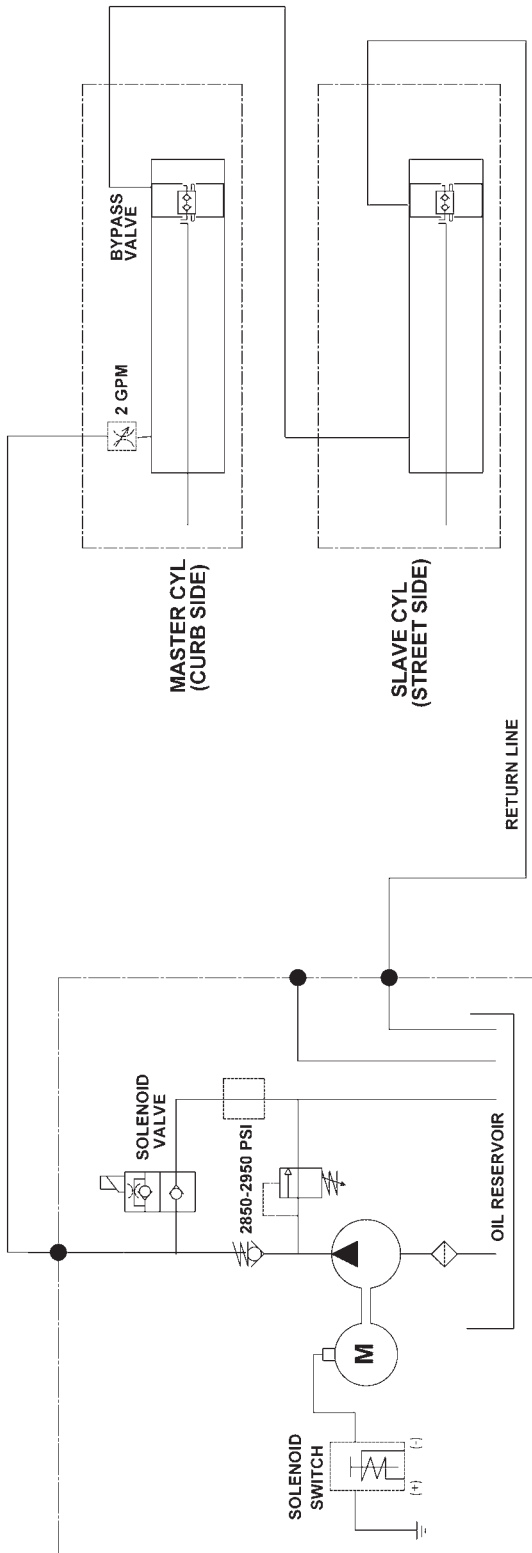

FIG. 44-1

MAXON®

11921 Slauson Ave. Santa Fe Springs, CA. 90670 (800) 227-4116 FAX (888) 771-7713

HYDRAULIC SCHEMATIC (EQUIPPED WITH HYDRAULIC CLOSER)

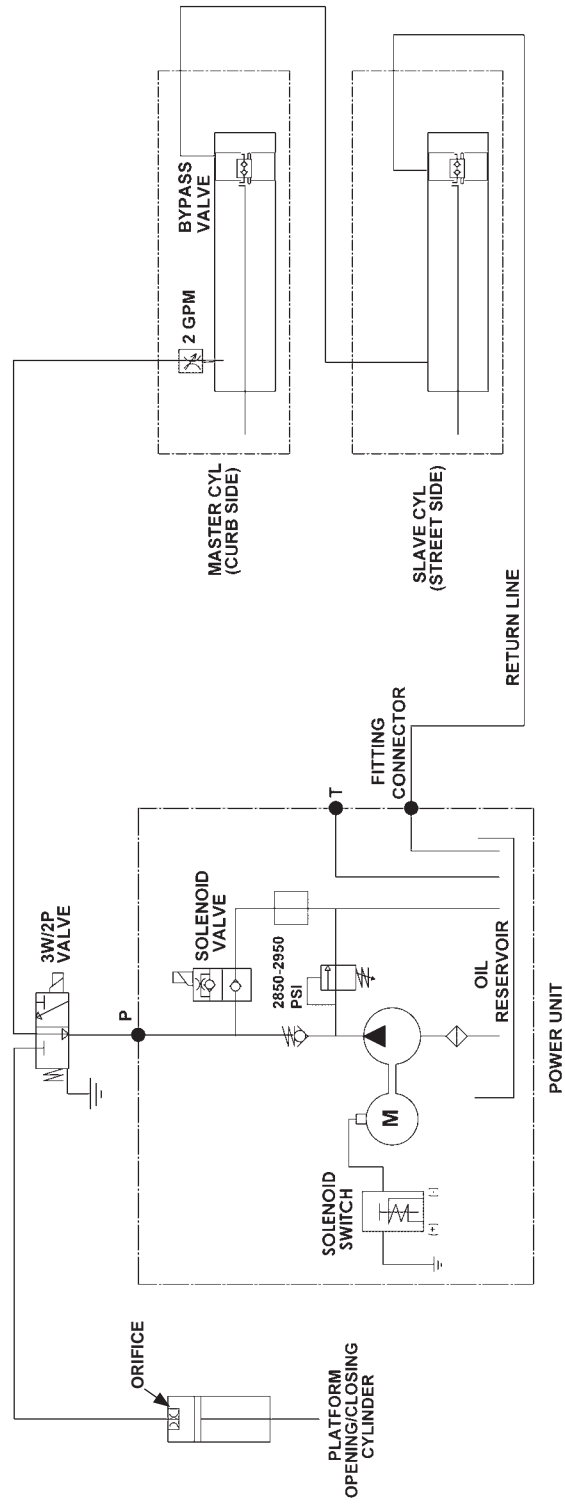

FIG. 45-1

SYSTEM DIAGRAMS - Continued

ELECTRICAL SCHEMATIC (MANUAL CLOSE)

MAXON®

11921 Slauson Ave. Santa Fe Springs, CA. 90670 (800) 227-4116 FAX (888) 771-7713

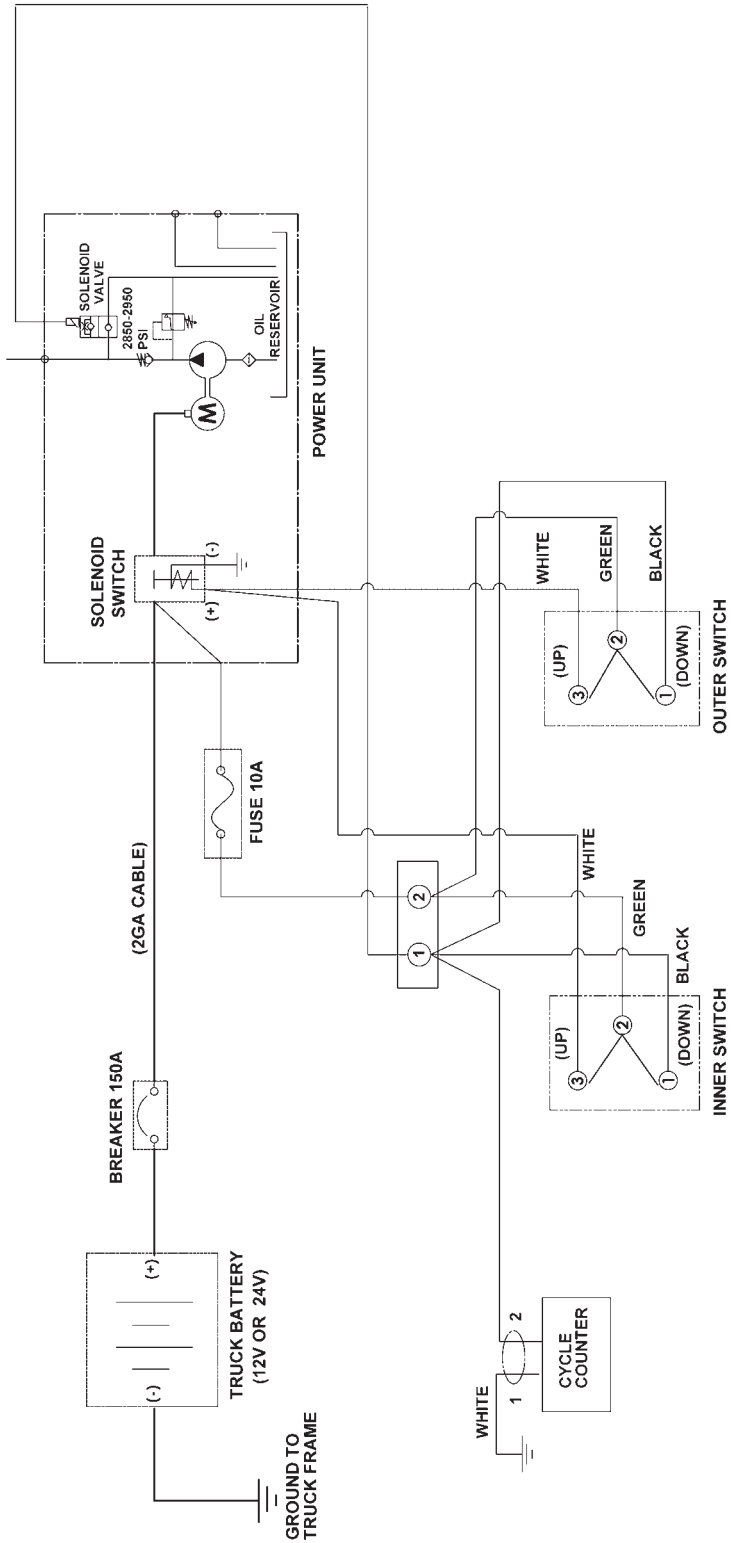

FIG. 46-1

ELECTRICAL SCHEMATIC (EQUIPPED WITH HYDRAULIC CLOSER)

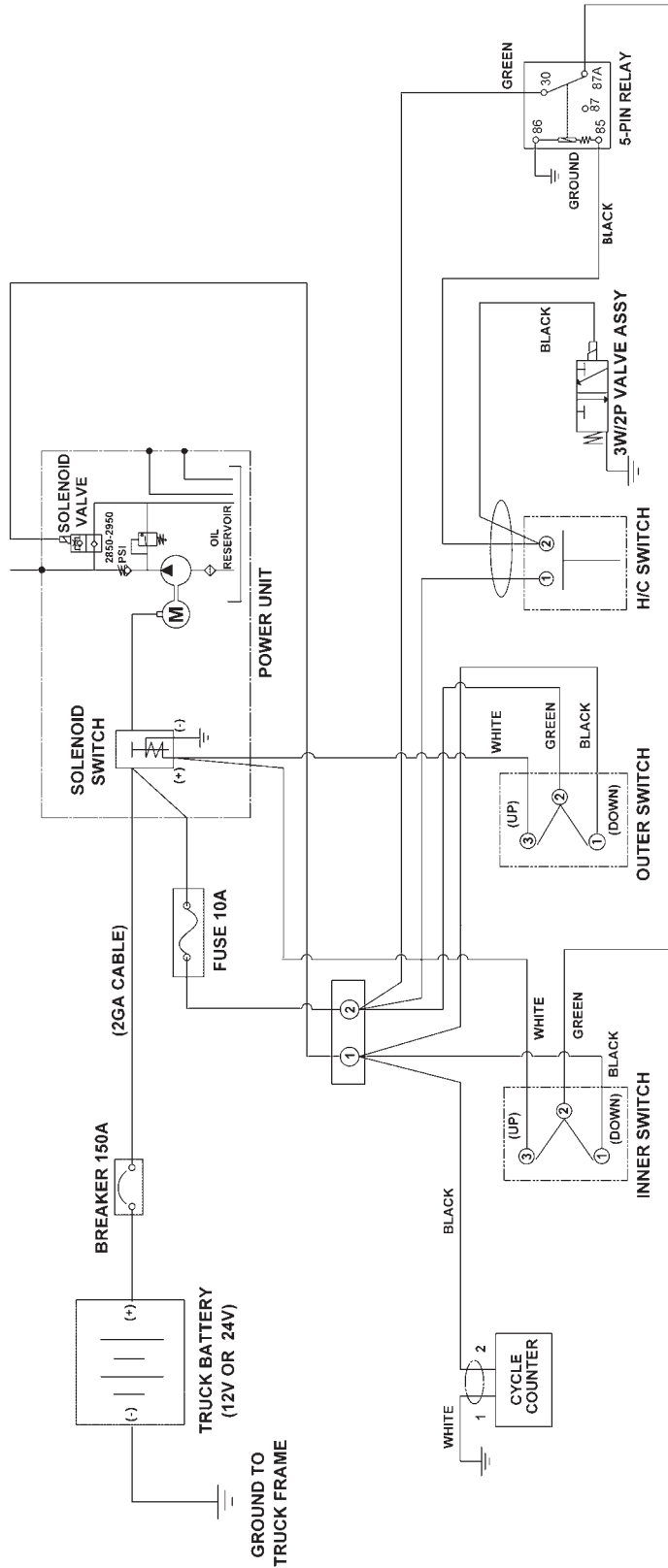

FIG. 47-1

SYSTEM DIAGRAMS - Continued

ELECTRICAL SCHEMATIC - JUMPER HARNESS ASSEMBLY

MAXON[®]

11921 Slauson Ave. Santa Fe Springs, CA. 90670 (800) 227-4116 FAX (888) 771-7713

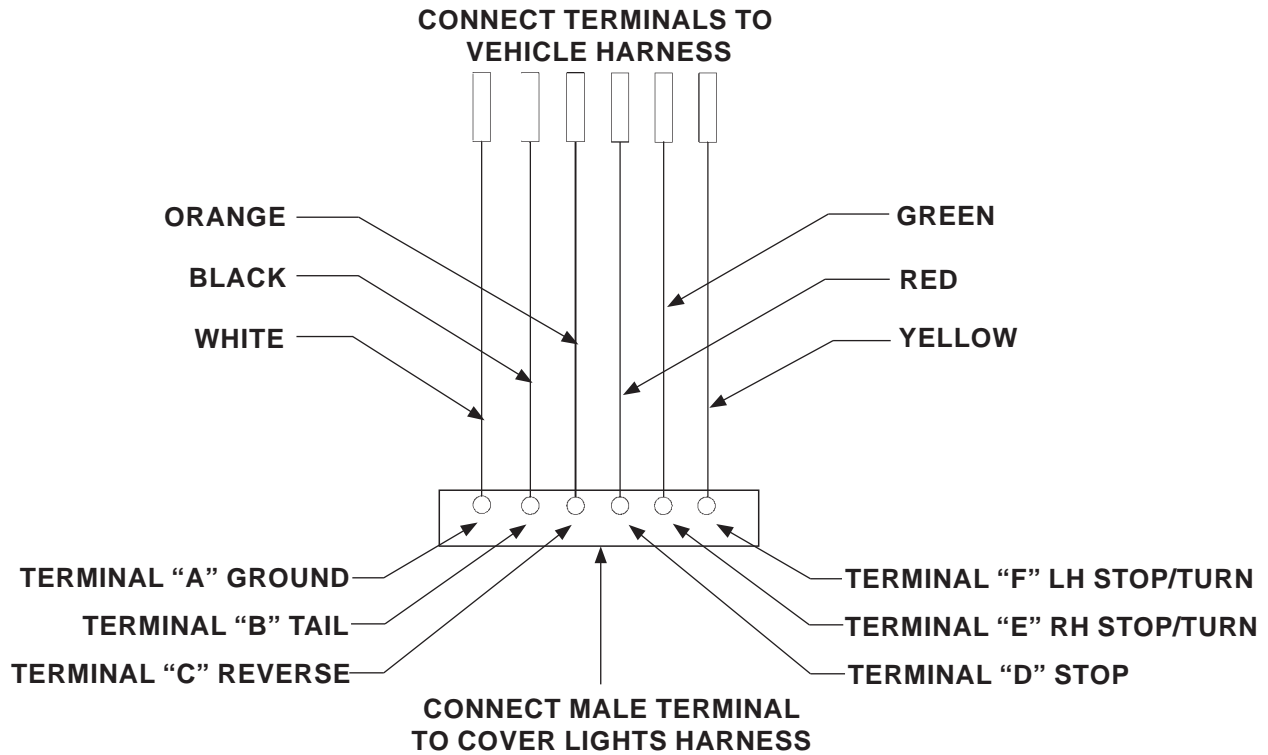

**FOREIGN/DOMESTIC
FIG. 48-1**

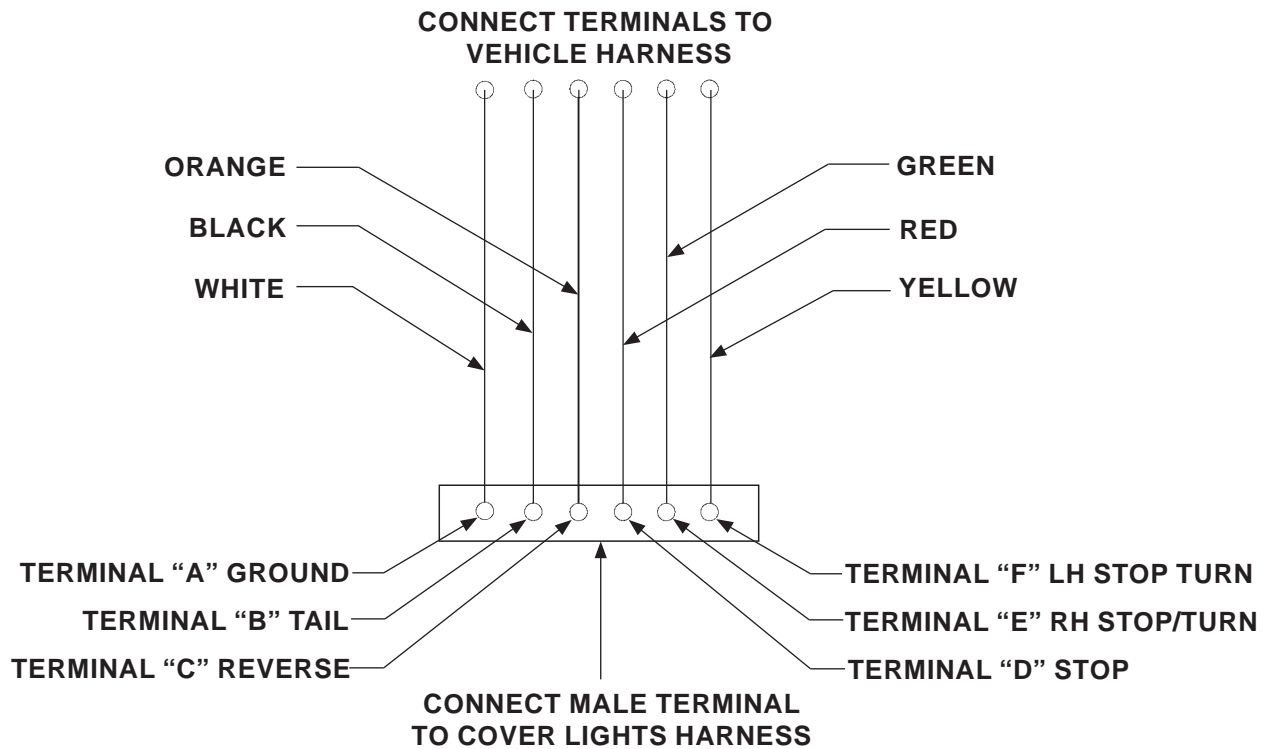

**ISUZU
FIG. 48-2**

**ELECTRICAL SCHEMATIC - HOUSING COVER ASSEMBLY
(WITHOUT LIGHTS)**

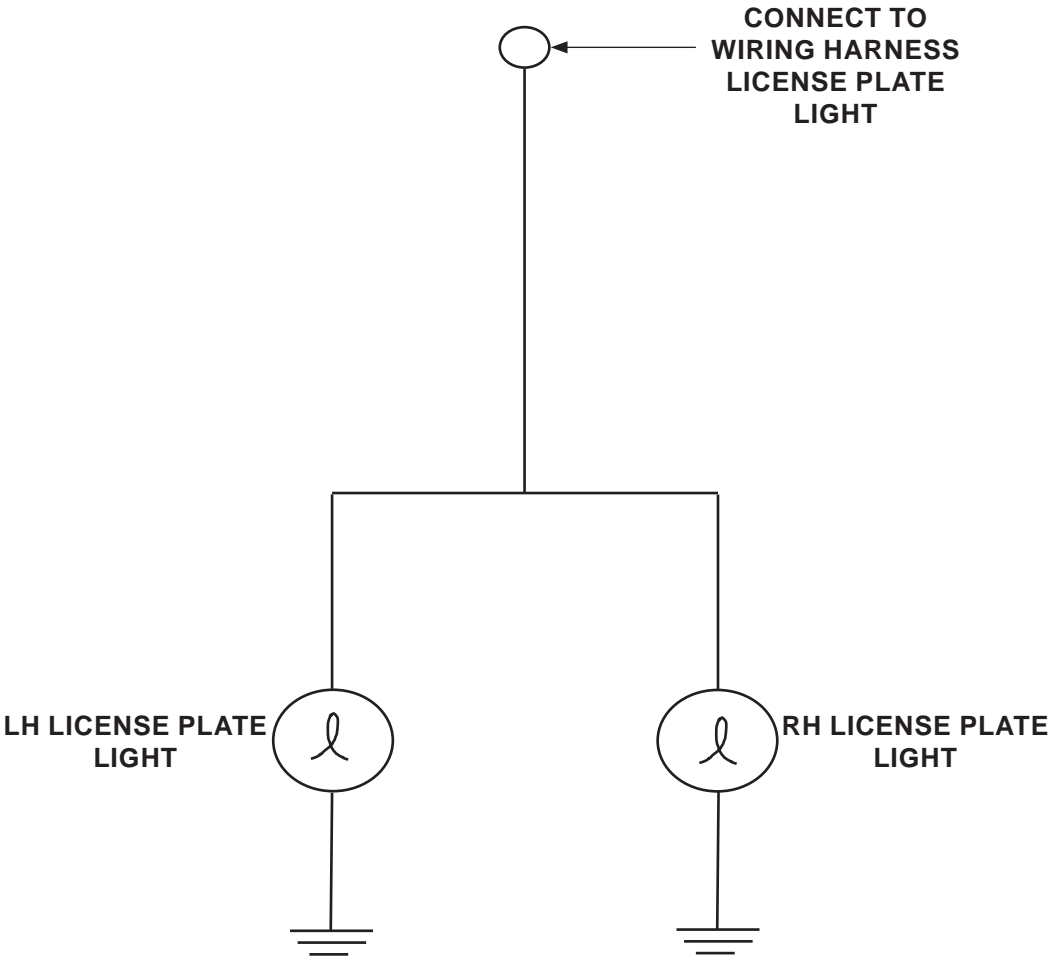

MAXON[®] 11921 Slauson Ave. Santa Fe Springs, CA. 90670 (800) 227-4116 FAX (888) 771-7713

FIG. 49-1

SYSTEM DIAGRAMS - Continued

ELECTRICAL SCHEMATIC - HOUSING COVER ASSEMBLY (WITH FOUR LIGHTS)

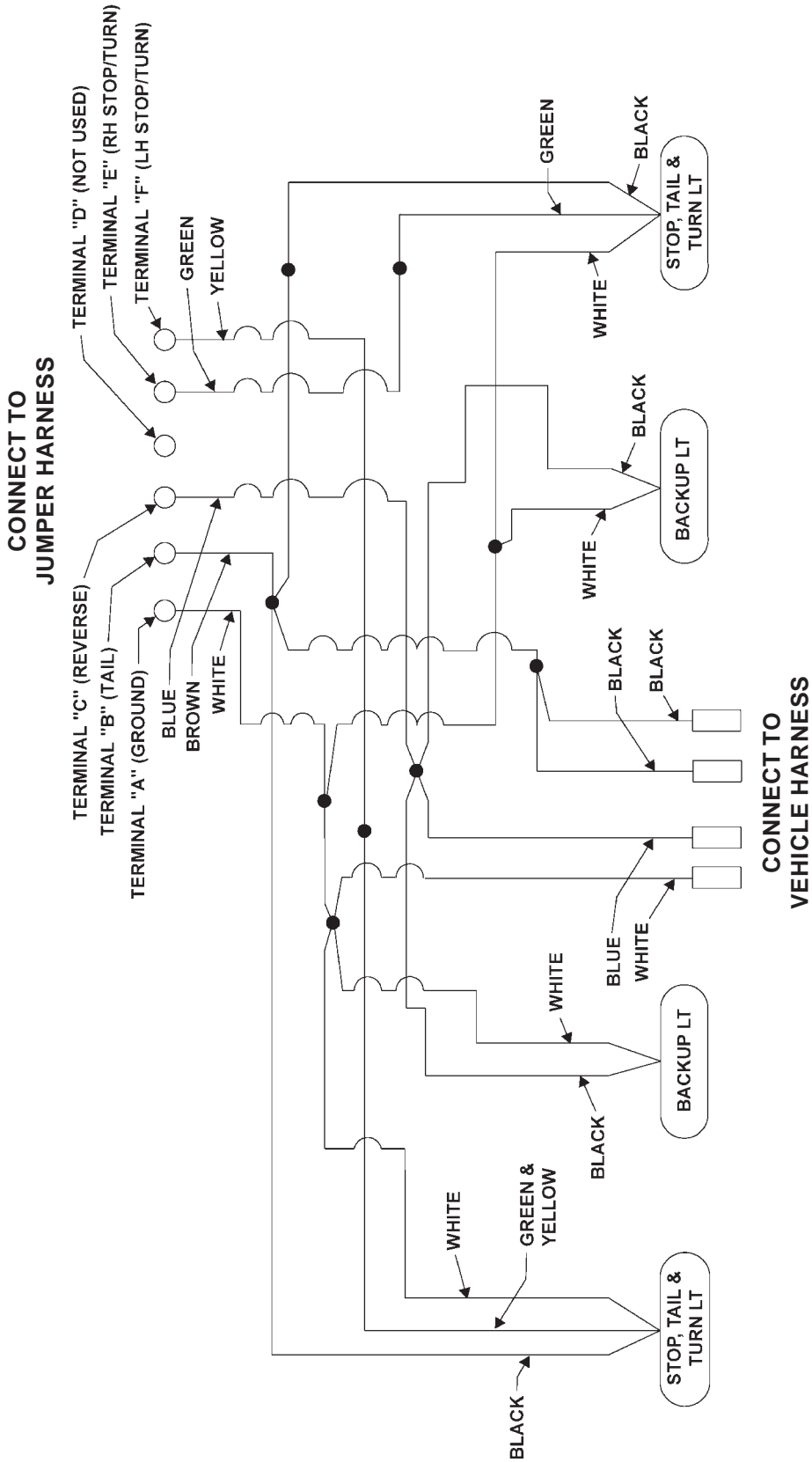

MAXON®

11921 Slauson Ave. Santa Fe Springs, CA. 90670 (800) 227-4116 FAX (888) 771-7713

ELECTRICAL SCHEMATIC - HOUSING COVER ASSEMBLY, FOREIGN VEHICLE (WITH 6 LIGHTS)

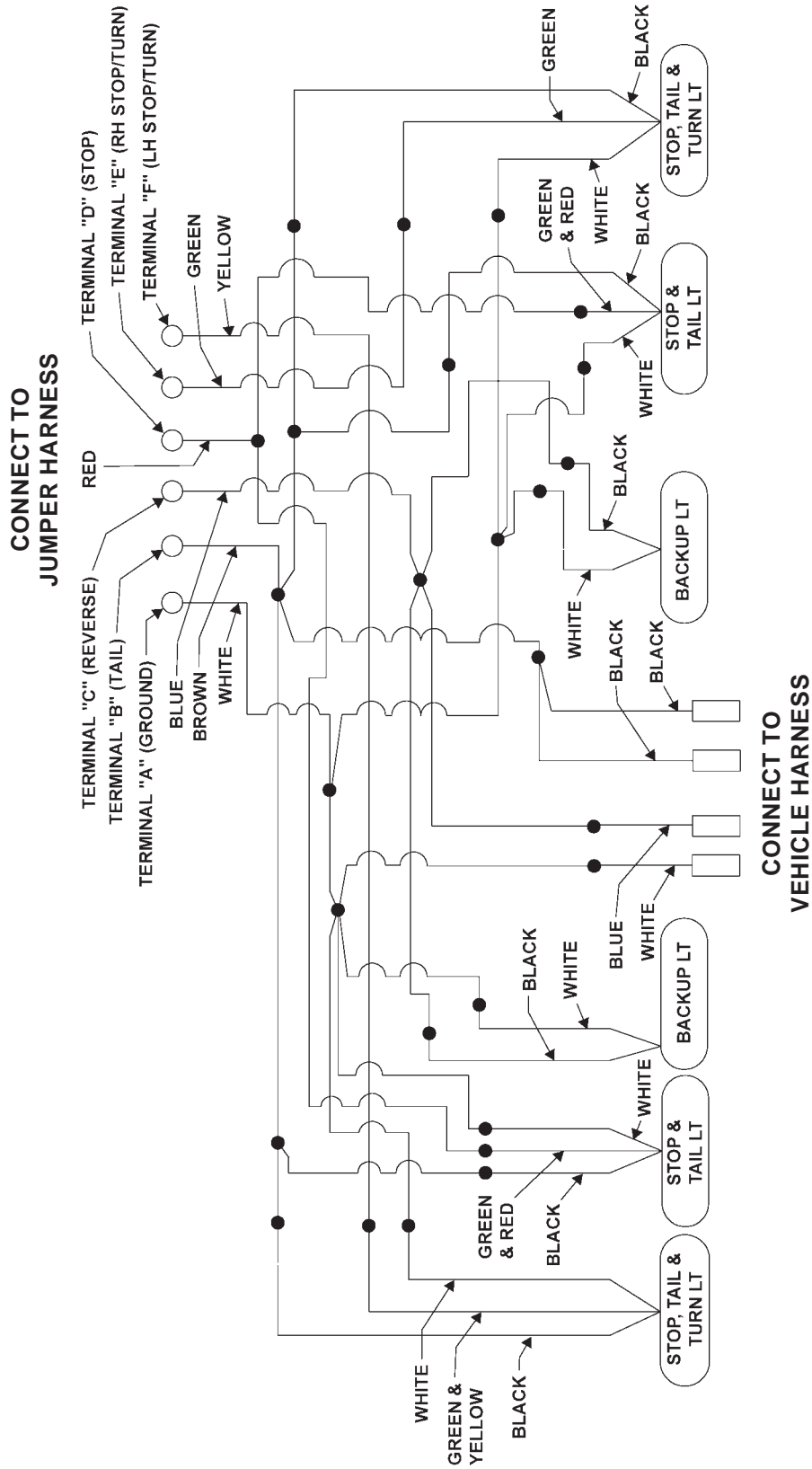

DMD ELECTRICAL VALUES & TORQUE SPECIFICATIONS

MAXON[®]

11921 Slauson Ave. Santa Fe Springs, CA. 90670 (800) 227-4116 FAX (888) 771-7713

SOLENOID SWITCH	12V	24V
Coil resistance:	5.4Ω @70°F. ±15%	20.1Ω @70°F. ±15%
Ampere:	2.2A	1.2A
Coil terminal torque: 10-15 lb-in max.		
Contact terminal torque: 30-35 lb-in max.		
LOWERING VALVE		
Coil resistance:	6.6Ω @ 70°F. ±15%	26.7Ω @ 70°F. ±15%
Ampere:	1.8A	0.9A
Coil terminal torque: 15-45 lb-in max.		
Valve cartridge torque: 25-30 lb-ft max.		
Coil nut torque: 15-45 lb-in		
FOLD/UNFOLD VALVE		
Coil resistance:	8.0Ω @ 70°F. ±15%	30Ω @ 70°F. ±15%
Ampere:	1.5A	0.8A
Coil terminal torque: 3-4.5 lb-ft max.		
Valve cartridge torque: 18.5-22 lb-ft max.		
GROUND CABLE		
Cap screw torque: 24 lb-ft max.		
CYCLE COUNTER		
Operation voltage	7V - 30V	7V - 30V
150 AMP CIRCUIT BREAKER		
1/4"-20 nut torque: 50 lb-in max.		

TABLE 52-1

BOLT TORQUES

CAUTION

The torque values in the following table are provided for torquing grade 8 bolts on Liftgate mechanical parts. To prevent damage, never use the information in this table for torquing electrical or hydraulic hose connections on the pump assembly.

GRADE 8 BOLT TIGHTENING TORQUE	
DIAMETER & THREAD PITCH	TORQUE
1/4"-20	10-14 lb-ft
1/4"-28	11-16 lb-ft
5/16"-18	20-29 lb-ft
5/16"-24	22-33 lb-ft
3/8"-16	35-52 lb-ft
3/8"-24	40-59 lb-ft
7/16"-14	56-84 lb-ft
7/16"-20	62-93 lb-ft
1/2"-13	85-128 lb-ft
1/2"-20	96-144 lb-ft
9/16"-12	123-184 lb-ft
9/16"-18	137-206 lb-ft
5/8"-11	170-254 lb-ft
5/8"-18	192-288 lb-ft
3/4"-10	301-451 lb-ft
3/4"-18	336-504 lb-ft

TABLE 53-1

