

M-16-39

REV E

NOVEMBER 2024

# MAXON<sup>®</sup>

## DMD Series

### OPERATION MANUAL

#### DMD-18, DMD-22 & DMD-33

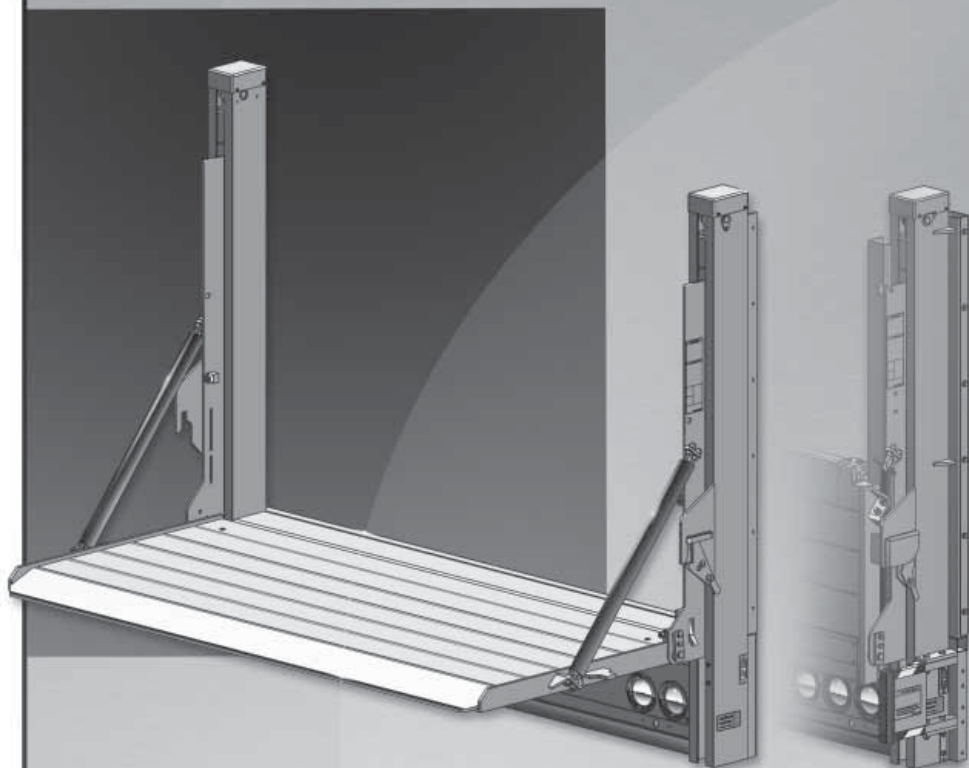
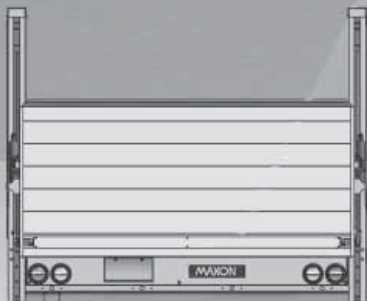

### KEEP THIS MANUAL INSIDE OF VEHICLE

Register your liftgate online at <http://www.maxonlift.com/support/product-registration>. For a free copy of other manuals that pertain to these liftgate models, please visit our website at [www.maxonlift.com](http://www.maxonlift.com) or call Customer Service at (800) 227-4116.

To find **maintenance & parts** information for your **DMD Liftgate**, go to [www.maxonlift.com](http://www.maxonlift.com). Click the **PRODUCTS, RAILIFT & DMD** buttons. Open the **Maintenance Manual** in the **PRODUCT DOCUMENTATION** window. For parts, click on the **PARTS PORTAL, RAILIFT & DMD** buttons.



# TABLE OF CONTENTS

<b>SUMMARY OF CHANGES: M-16-39 REVISION E</b> .....	<b>4</b>
<b>WARNINGS</b> .....	<b>5</b>
LIFTGATE TERMINOLOGY .....	6
<b>RECOMMENDED DAILY OPERATION CHECKS</b> .....	<b>8</b>
<b>DECALS</b> .....	<b>10</b>
DECALS & PLATES .....	13
<b>FORKLIFT ADVISORY</b> .....	<b>15</b>
<b>OPERATION</b> .....	<b>16</b>
UNFOLDING THE PLATFORM.....	16
<b>LOADING VEHICLE</b> .....	<b>19</b>
LOWERING THE PLATFORM .....	19
POSITIONING LOAD .....	20
RAISING & UNLOADING PLATFORM.....	21
<b>UNLOADING VEHICLE</b> .....	<b>22</b>
LOWERING THE PLATFORM .....	22
RAISING THE PLATFORM .....	22
POSITIONING LOAD .....	23
LOWERING & UNLOADING PLATFORM.....	24
<b>STOWING PLATFORM</b> .....	<b>25</b>
USING STANDARD CART STOPS (IF EQUIPPED) .....	28
USING RETENTION RAMP (IF EQUIPPED).....	31

# SUMMARY OF CHANGES: M-16-39 REVISION E

PAGE	DESCRIPTION OF CHANGE
COVER	Updated REV. and date of release.
7	Added Terminology page for DMD with dock bumpers.
10	Added WARNING decal P/N 212449-01 and NOTE that decals are preinstalled at the factory.
10, 12	Replaced decal sheet P/N 298155-03 with P/N 212464-01.
11, 14	Added decal pages for DMD with dock bumpers.
17	Added important NOTICE about the transit hook.

## **WARNING**

1. Incorrect operation of this Liftgate can result in serious personal injury. Comply with **WARNINGS** and Liftgate operating instructions in this manual. Do not allow untrained persons or children to operate the Liftgate. If you need to replace an **Operation Manual**, additional copies are available from:

**MAXON Lift Corp. Customer Service**  
**11921 Slauson Ave**  
**Santa Fe Springs, CA 90670**  
**(800) 227-4116**
2. Do not exceed rated **load capacity of 1800 lb for DMD-18 Liftgate, 2200 lb for DMD-22 Liftgate, and 3300 lb for DMD-33 Liftgate.**
3. Do not allow any part of your body to be placed under, within, or around any portion of the moving Liftgate or its mechanisms, or in a position that would trap them between the platform and the floor of truck body (or between platform and the ground) when Liftgate is operated.
4. Consider the safety and location of bystanders and location of nearby objects when operating the Liftgate. Stand to one side of platform while operating the Liftgate. Be certain that the area the Liftgate will move through during operation is clear of all obstacles.
5. Comply with all attached instruction decals and warning decals.
6. Keep decals clean and legible. If decals are illegible or missing, have them replaced. **Get free replacement decals from Maxon.**
7. **Never drive a forklift on the Liftgate platform.**
8. Do not move vehicle unless Liftgate is correctly stowed.
9. **Correctly stow platform when not in use. Extended platforms could create a hazard for people and vehicles passing by.**
10. A correctly installed Liftgate will operate smoothly and reasonably quiet. The only noticeable noise during Liftgate operation is from the power unit while the platform is being lowered and raised. Listen for scraping, grating and binding noises and have the problem corrected before continuing to operate the Liftgate.
11. Above all, **USE GOOD COMMON SENSE** when operating this Liftgate.
12. Never use a cell phone while operating the Liftgate.

# LIFTGATE TERMINOLOGY

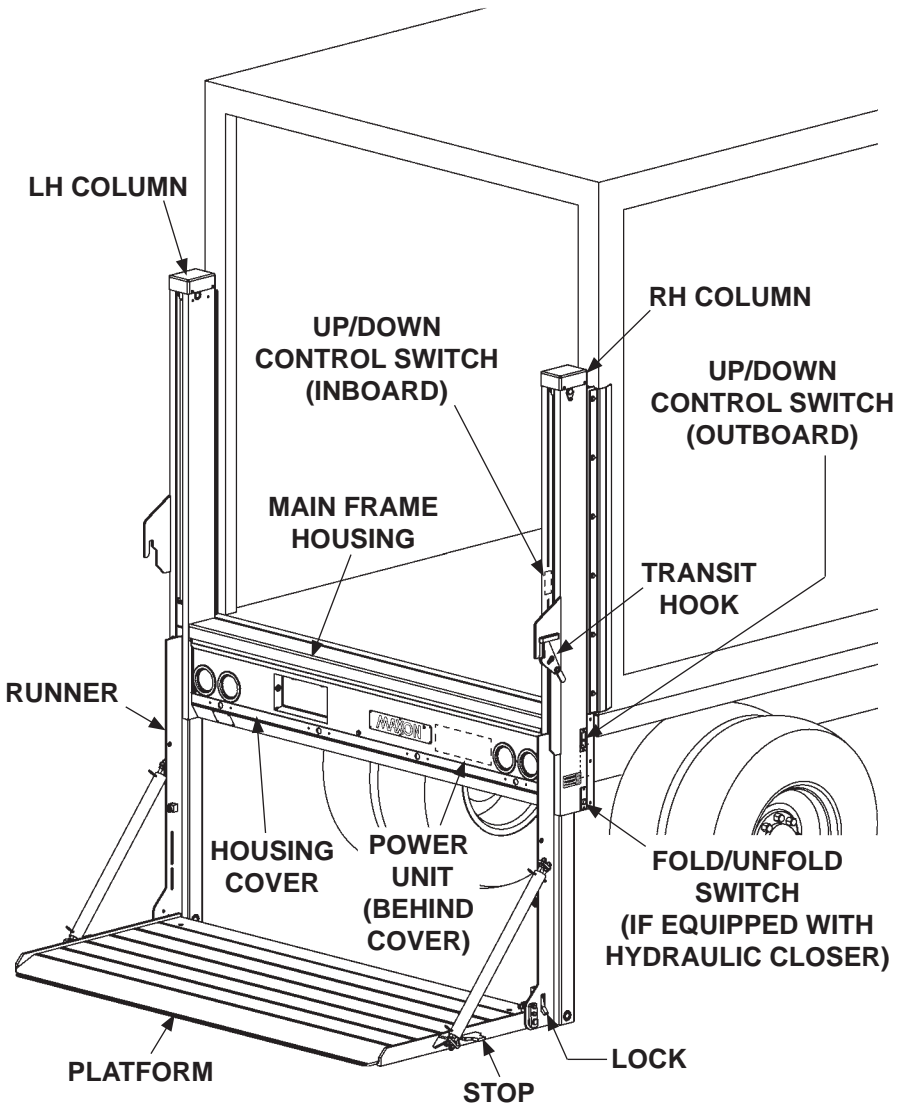

# LIFTGATE TERMINOLOGY - DMD WITH DOCK BUMPERS

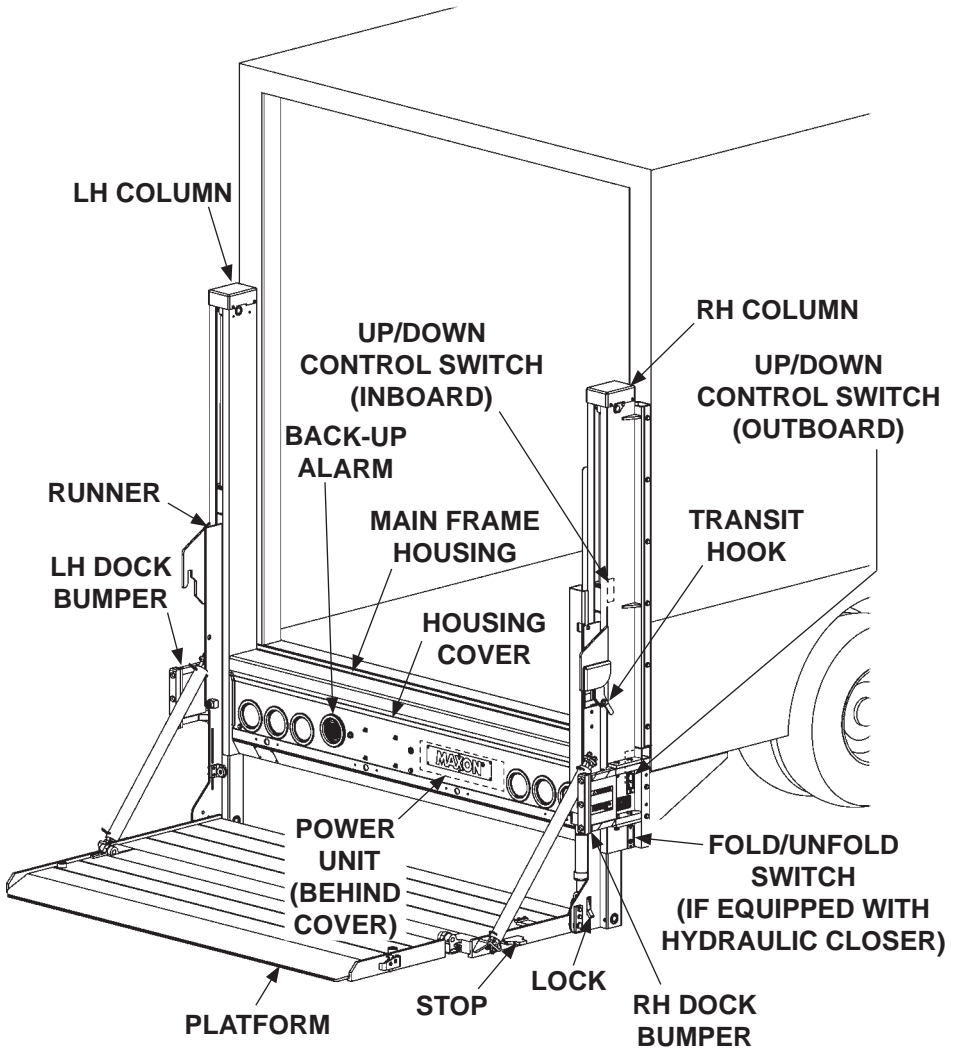

# RECOMMENDED DAILY OPERATION CHECKS

**NOTE:** Before you check the Liftgate, park vehicle on flat ground and set the parking brake.

**NOTE:** If any of the following operation checks reveal a need to service or repair Liftgate, do not operate the Liftgate until a qualified mechanic services or repairs the Liftgate.

## Before operating the Liftgate, the operator should do the following:

- Make sure batteries are fully charged, battery terminal connections are clean and tight, and battery box is undamaged.
- Make sure cab cutoff switch is **ON**, if equipped.
- Visually check that main frame housing cover is bolted on securely and undamaged. Look for hydraulic fluid leaks from main frame and columns.
- Follow the visible routing of hydraulic hoses from cylinders to main frame housing. Make sure all hoses are connected at both ends and there are no cracks, chafing, and fluid leaks.
- Visually check that standard and optional controls are in place and undamaged.
- Visually check that all decals are in place (see **DECALS** page). Make sure decals are legible, clean, and undamaged.

## Use the operation instructions in this manual to unfold the platform.

- Position top surface of platform at vehicle bed level. Check if platform surface is even with liftgate main housing across the width of the platform. If platform is uneven, press **UP** button on control switch until platform stops. Hold for 10 seconds more to get platform even.
- Check for smooth operation as platform unfolds and as runners lower the platform to the ground.
- Check main frame housing, columns, runners and platform openers for cracks and bends. Make sure platform chains are undamaged and connected securely at both ends. Also, make sure all bolts and pins are in place and undamaged.
- Check platform and flipover for cracks, holes, and bends on the load carrying surfaces and side plates. Also, make sure retention ramps and carts stops (if equipped) are undamaged and operate smoothly.



- Make sure load-carrying surfaces on main frame housing, platform, flipover, and retention ramp (if equipped) are clean (no oil, debris, or corrosion).
- Check for fluid leaks from hydraulic cylinders.

**Use the operation instructions in this manual to operate the Liftgate through one cycle without a load on the platform. Raise the platform to vehicle bed height. Next, lower the platform to ground level.**

- When raising and lowering platform, listen for unusual noises and look for a “jerking” motion or uneven movement at LH and RH sides of the platform. Uneven movement should not exceed 1”.
- With platform at bed height, make sure the LH and RH platform chains feel even in tightness.
- Retention ramps (if equipped) release, unfold and fold smoothly, and remains in ramp, retention, and stowed positions until intentionally moved.
- Carts stops (if equipped) release, open, and close smoothly and remain so until intentionally opened or stowed.

**If service or repairs are not required (or if completed), stow platform for transport.**

# DECALS

**NOTE:** Decals are preinstalled at factory. Decal location shown for reference.

**NOTE:** Ensure there is no residue, dirt or corrosion where decals are attached. If necessary, clean surface before replacing decals.

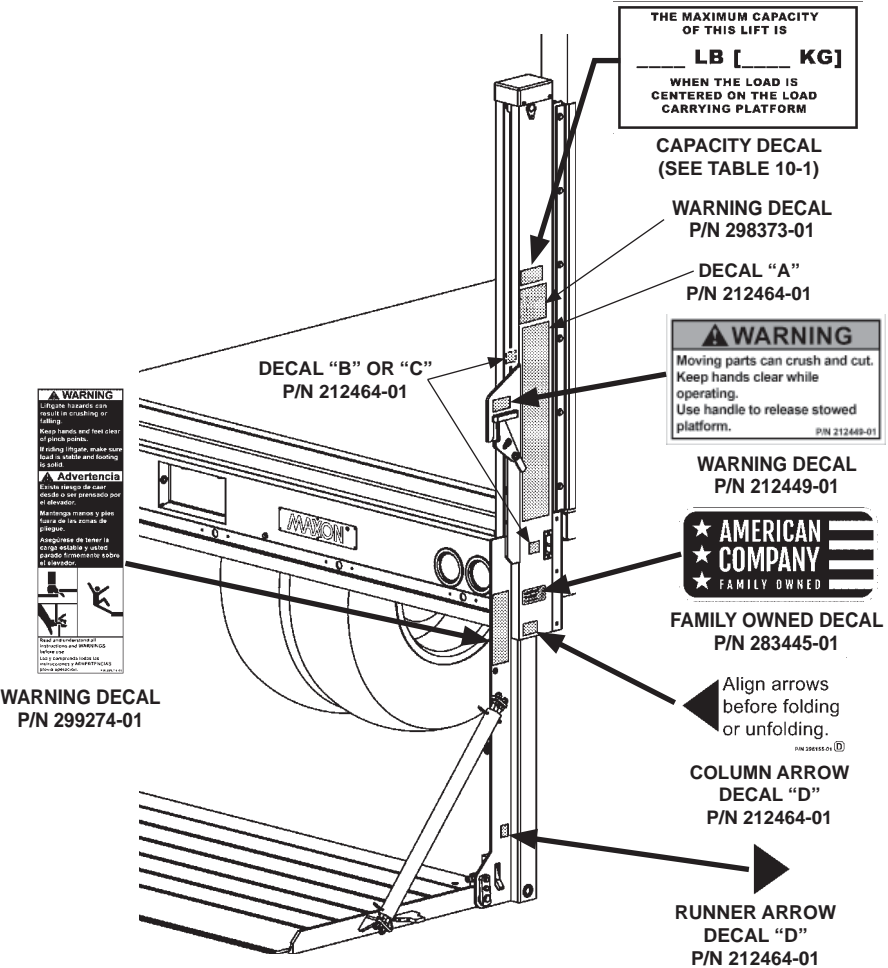

MODEL	ORDER P/N	CAPACITY DECAL
DMD-18	220387-04	1800 LB [817 KG]
DMD-22	220388-03	2200 LB [1000 KG]
DMD-33	220388-02	3300 LB [1500 KG]

**DECAL SHEET PART NUMBERS  
TABLE 10-1**

# DECALS - DMD WITH DOCK BUMPERS

**NOTE:** Decals are preinstalled at factory. Decal location shown for reference.

**NOTE:** Ensure there is no residue, dirt or corrosion where decals are attached. If necessary, clean surface before replacing decals.

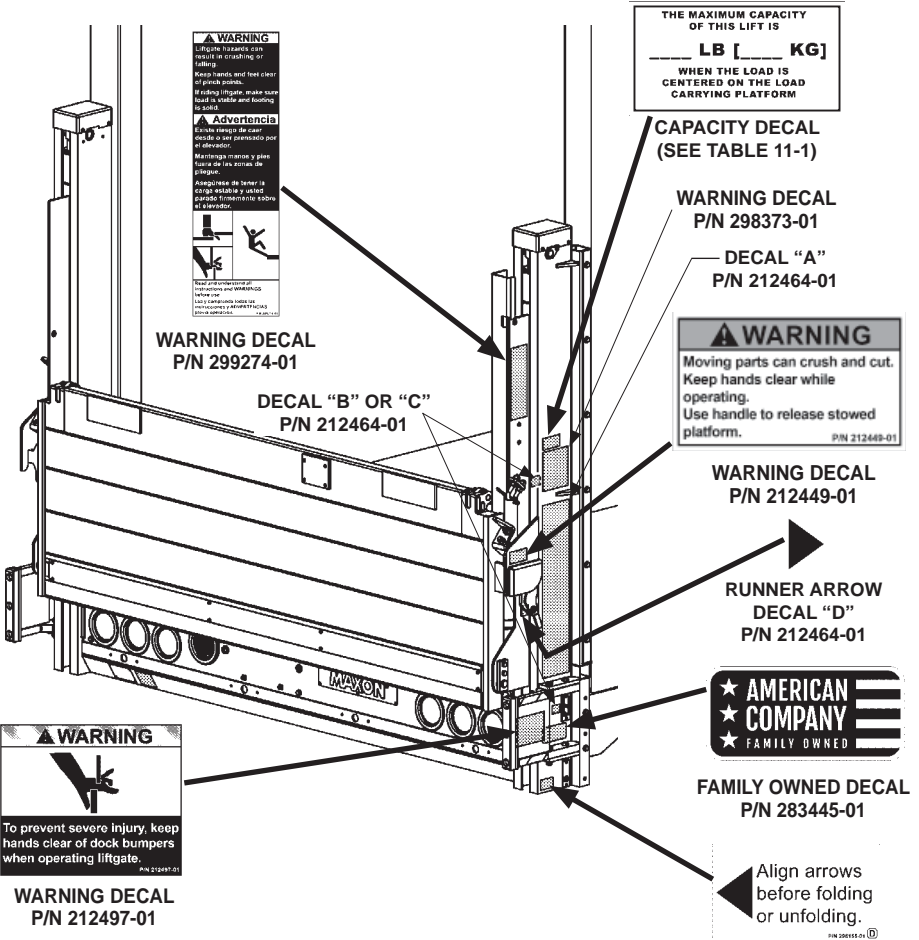

MODEL	ORDER P/N	CAPACITY DECAL
DMD-18	220387-04	1800 LB [817 KG]
DMD-22	220388-03	2200 LB [1000 KG]
DMD-33	220388-02	3300 LB [1500 KG]

**DECAL SHEET PART NUMBERS  
TABLE 11-1**

**COLUMN ARROW  
DECAL "D"  
P/N 212464-01**

# DECALS - Continued

**CAUTION**

Always stand clear of platform area.

**WARNING**

Liftgate hazards can result in crushing or falling.

Keep hands and feet clear of pinch points.

If riding liftgate, make sure load is stable and footing is solid.

**WARNING**

Read the instructions carefully.

Improper operation of this device can result in serious personal injury. If you do not make a copy of the operating instructions, please adhere to them from your employer's instructions. Do not use this liftgate until these instructions have been translated.

1. Place the warning pin on each side of the liftgate.

2. Do not operate in bad or uneven terrain.

3. Do not operate on uneven or uneven terrain, or on any surface that is not level, or on any surface that is not level, or on any surface that is not level, or on any surface that is not level.

4. If a hazard is riding the platform, make sure you are both standing on the platform and that you are not in danger of coming in contact with any moving or potentially moving equipment.

5. **USE WOOD COMMON SENSE.**

6. If a load appears to be unstable, do not lift or lower it.

7. An operator of this equipment must be trained, aged, and fit to operate in accordance with applicable laws and regulations.

**OPERATING INSTRUCTIONS**

Scan this QR code to see operation manual or video.

**OPERATE**      **STOW**

<p><b>RAISE PLATFORM OFF TRANSPORT HOOK &amp; LOWER TO UNLOCK.</b></p>	<p><b>FOLD &amp; LOCK PLATFORM IN SUPPORTING POSITION.</b></p>
<p><b>LOWER PLATFORM AT OR BELOW SUPPORT POSITION.</b></p>	<p><b>RAISE PLATFORM AT OR BELOW SUPPORT POSITION.</b></p>
<p><b>RELEASE PLATFORM LOCK &amp; UNFOLD.</b></p>	<p><b>RAISE PLATFORM LOCK &amp; FOLD &amp; LOCK.</b></p>
<p><b>UNLOCK &amp; UNFOLD PLATFORM IF EQUIPPED.</b></p>	<p><b>RAISE PLATFORM ABOVE TRANSPORT HOOK.</b></p>
<p><b>RAISE LOWER PLATFORM.</b></p>	<p><b>MAKE SURE TRANSPORT HOOK SETS TO POSITION.</b></p>

**SAFETY INSTRUCTIONS**

Rotate handle to release stowed platform.

**SAFETY INSTRUCTIONS**

Read all safety and operation manuals before operating liftgate.

1. Do not use liftgate unless you have been properly instructed and these rules, and are familiar with, the operating instructions.

2. Do not operate in bad or uneven terrain.

3. Do not operate on uneven or uneven terrain, or on any surface that is not level, or on any surface that is not level, or on any surface that is not level, or on any surface that is not level.

4. Make certain platform area, including the area in which loads may fall from the lift, is clear before use at all times during operation.

5. This liftgate is intended for loading and unloading of cargo only. Do not use this liftgate for anything but its intended use.

UP      DOWN

PIN 289155-03 (B)

DOWN      UP

PIN 289155-03 (C)

Align arrows before folding or unfolding.

PIN 291560-01 (D)

**WARNING**

A liftgate extending from a moving vehicle could injure bystanders & damage property. Stow liftgate in correct transit position before moving vehicle.

**Advertencia**

Un elevador hidráulico abierto en vehículo en movimiento puede ocasionar daños y lesiones a objetos y personas circundantes. Cierre apropiadamente antes de poner el vehículo en movimiento.

**WARNING DECAL**  
P/N 298373-01

**WARNING**

Liftgate hazards can result in crushing or falling.

Keep hands and feet clear of pinch points.

If riding liftgate, make sure load is stable and footing is solid.

**Advertencia**

Existe riesgo de caer desde o ser prensado por el elevador.

Mantenga manos y pies fuera de las zonas de pliegue.

Asegúrese de tener la carga estable y usted parado firmemente sobre el elevador.

Read and understand all instructions and WARNINGS before use.

Lea y comprenda todas las instrucciones y ADVERTENCIAS previa operación.

**WARNING DECAL**  
P/N 299274-01

**DECAL SHEET**  
P/N 212464-01

**FIG. 12-1**

# DECALS & PLATES

**NOTE:** Preferred decal layout is shown. Decals on the Liftgate are attached at the factory, except for the 24/7 SUPPORT decal. The 24/7 SUPPORT decal is placed at customer's or installer's preference.



**MAXON 24/7  
SUPPORT DECAL  
P/N 298634-01**

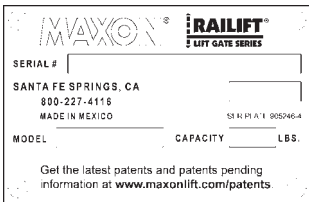

**SERIAL PLATE  
(REF)**



**PARTS QR CODE DECAL  
P/N 299143-01**

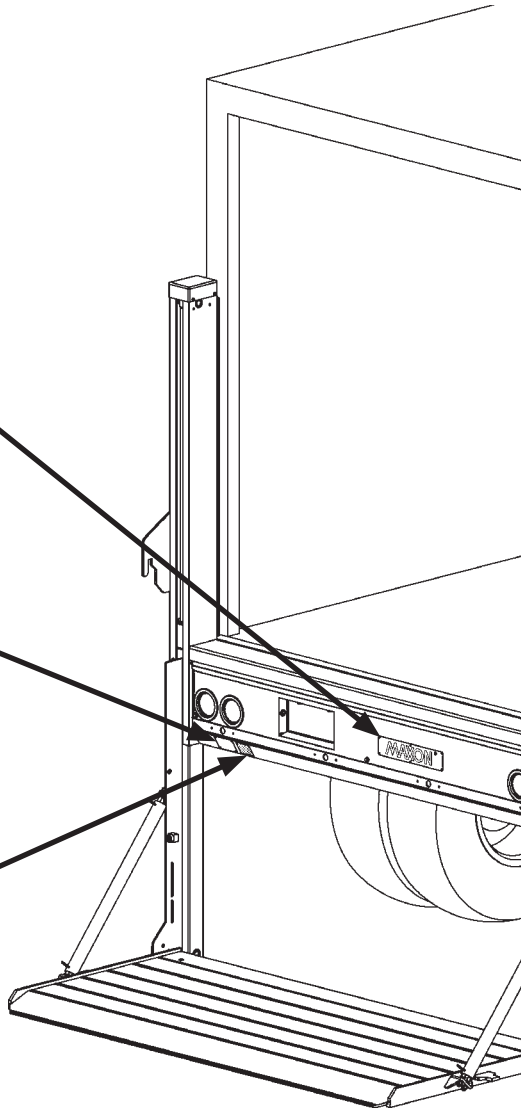

**FIG. 13-1**

# DECALS & PLATES - DMD WITH DOCK BUMPERS

**NOTE:** Preferred decal layout is shown. Decals on the Liftgate are attached at the factory, except for the 24/7 SUPPORT decal. The 24/7 SUPPORT decal is placed at customer's or installer's preference.

**MAXON 24**

24/7 LIFTGATE SUPPORT

- Around-the-clock nationwide assistance
- Trained technicians on-call to diagnose and troubleshoot

866 MAXON 24  
(866) 629-6624  
maxonlift.com/24

PN 298634-01

**MAXON 24/7  
SUPPORT DECAL  
P/N 298634-01**

**MAXON** **RAILIFT**  
LIFTGATE SERVICE

SERIAL # \_\_\_\_\_  
SANTA FE SPRINGS, CA  
866-227-4118  
MADE IN MEXICO © 2014 MAXON

MODEL \_\_\_\_\_ CAPACITY \_\_\_\_\_ LBS.

Get the latest patents and patents pending information at: [www.maxonlift.com/patents](http://www.maxonlift.com/patents)

**SERIAL PLATE  
(REF)**

**MAXON**  
Scan for Parts Breakdown



Escanee para el desglose de partes  
P/N 299143-01

**PARTS QR CODE  
DECAL  
P/N 299143-01**

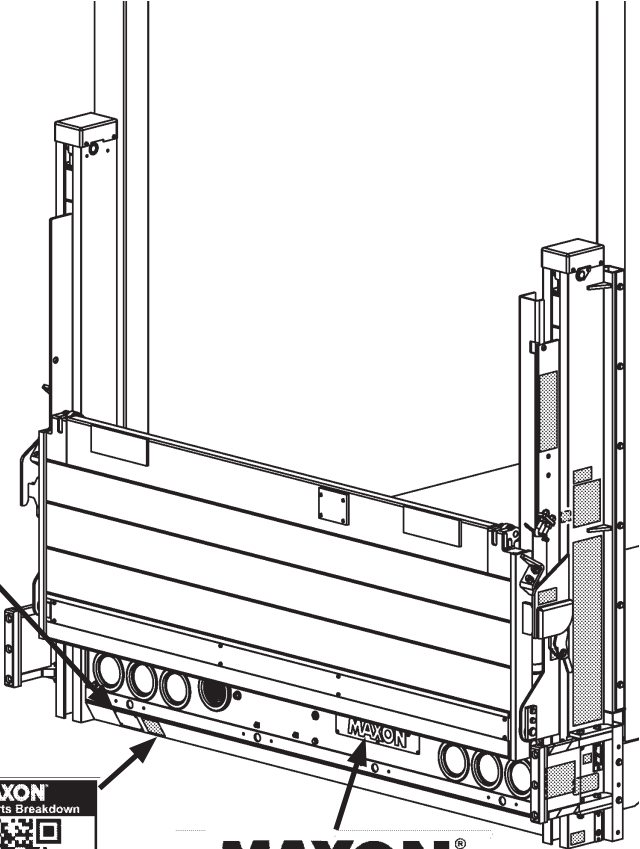

**MAXON**<sup>®</sup>  
CAUTION Moving Parts

**MAXON NAME PLATE  
P/N 050175**

**FIG. 14-1**

# FORKLIFT ADVISORY

**⚠ WARNING**  
Keep forklift OFF of platform.

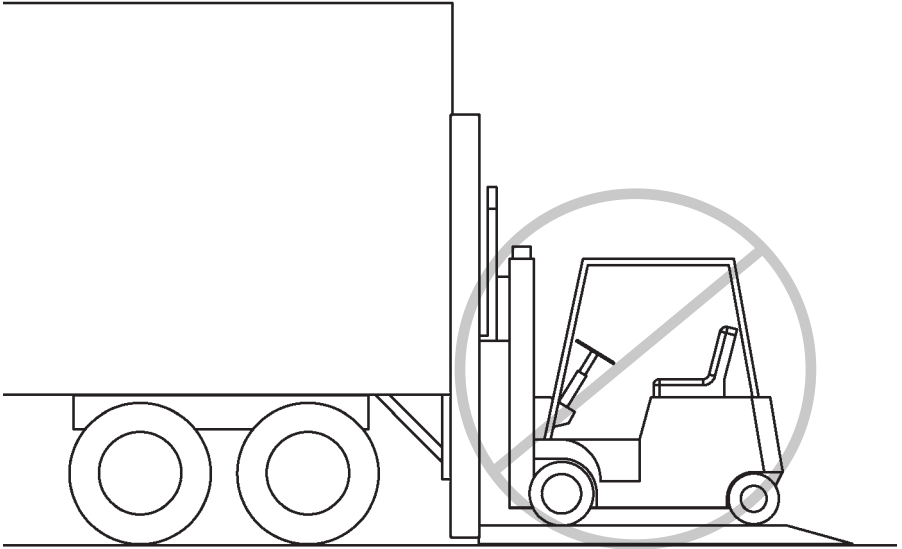

FIG. 15-1

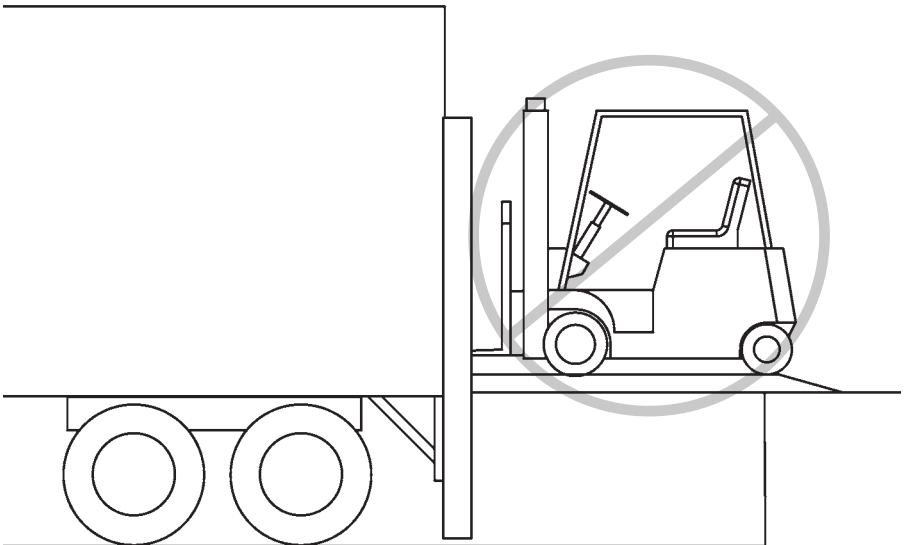

FIG. 15-2

# OPERATION

## UNFOLDING THE PLATFORM

**NOTE:** Do **RECOMMENDED DAILY OPERATION CHECKS** at the beginning of this manual.

1. Raise platform stop off transit hook (FIGS. 16-1 and 16-1A) by pushing the outboard control switch to **UP** position (FIG. 16-1).

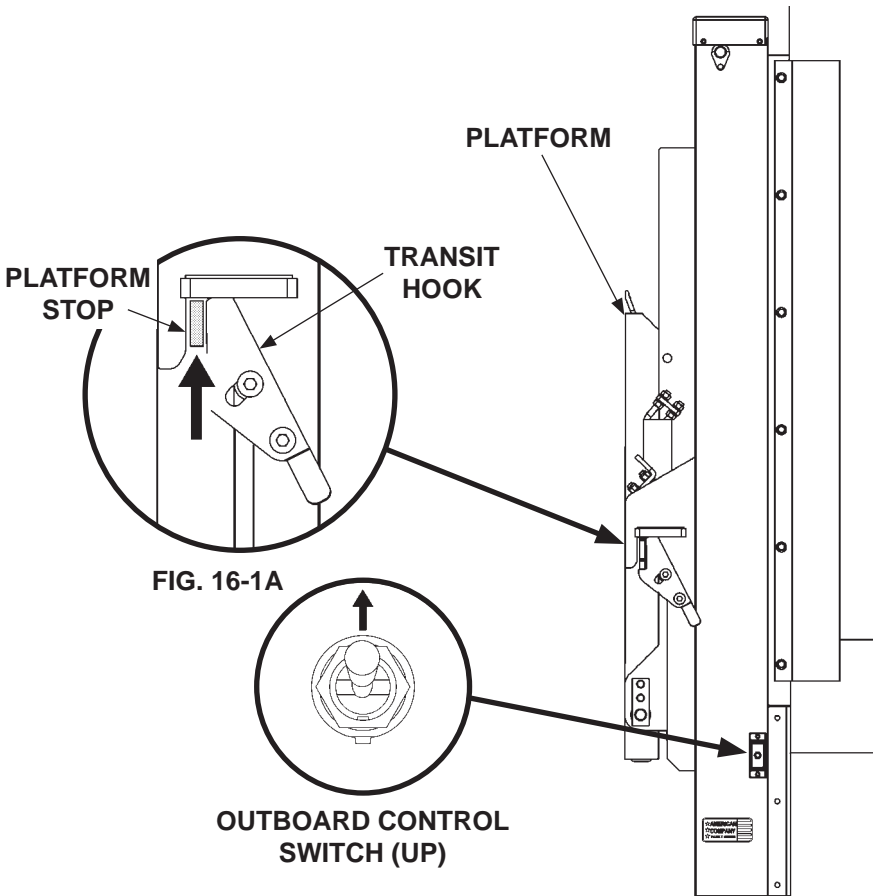

**RAISING PLATFORM STOP OFF HOOK**  
**FIG. 16-1**



**NOTICE**

Before handling transit hook, refer to **SAFETY INSTRUCTIONS** on decal A.

2. Rotate transit hook away from platform stop (FIG. 17-1A). Push outboard control switch **DOWN** (FIG. 17-1) to lower the platform until platform stop clears transit hook and arrow decals align on column and runner (FIG. 17-1).

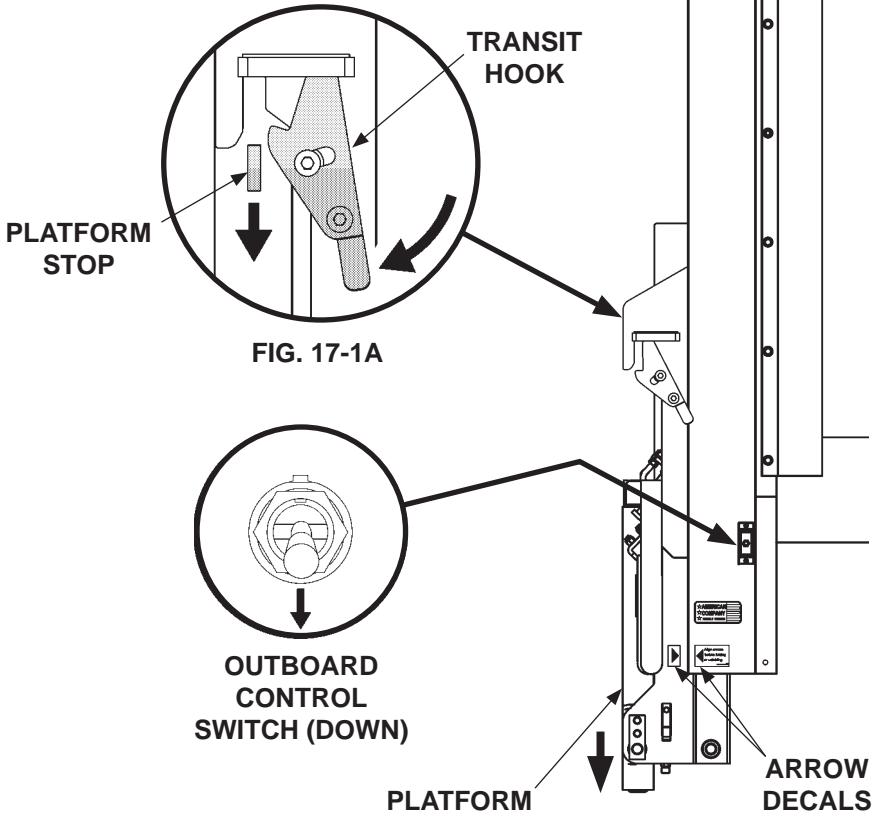

**LOWERING PLATFORM TO ALIGN ARROWS**  
**FIG. 17-1**

## UNFOLDING THE PLATFORM - Continued

**NOTE:** If platform is equipped with hydraulic closer, do step 4.

3. For manual close Liftgate, push platform lock up to unlock the platform (**FIG. 18-1A**). Manually unfold platform (**FIG. 18-1**). Next, push platform lock down to lock platform (**FIG. 18-1B**).

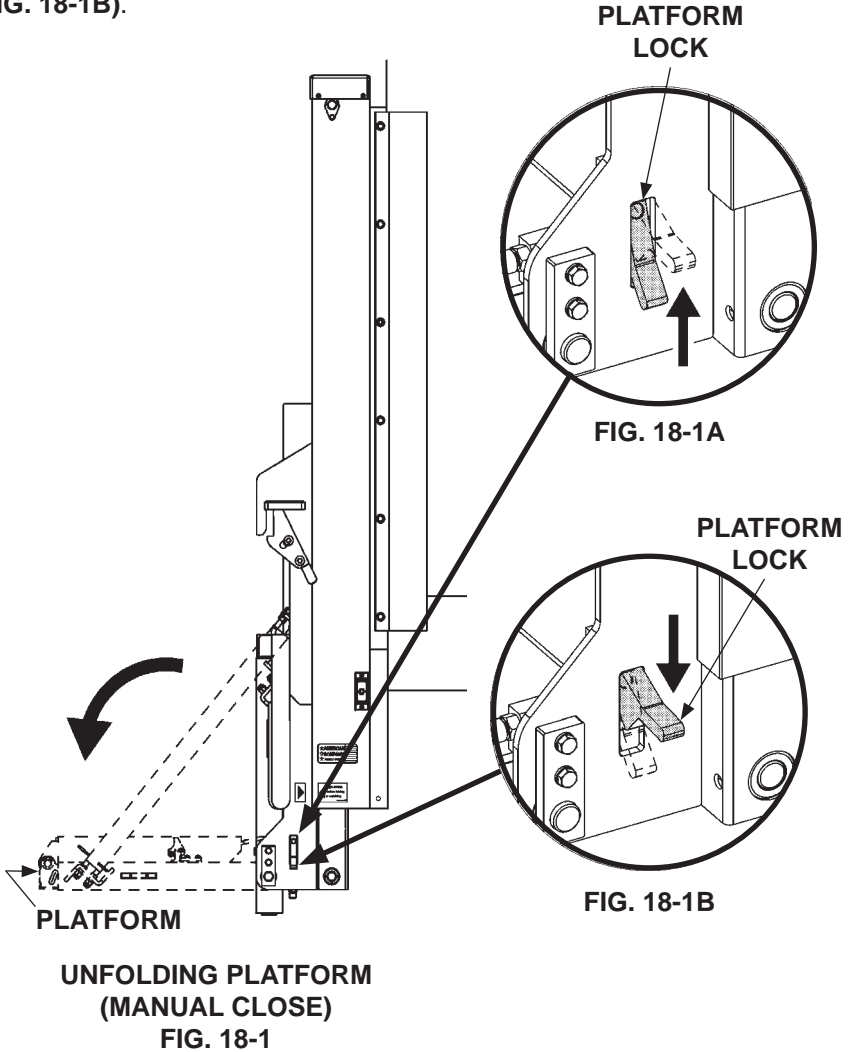

# LOADING VEHICLE

## LOWERING THE PLATFORM

4. For Liftgate equipped with hydraulic closer, hold power closer switch (**FIG. 19-1**) and outboard control switch (**DOWN**) at the same time to unfold platform (**FIG. 19-1**).

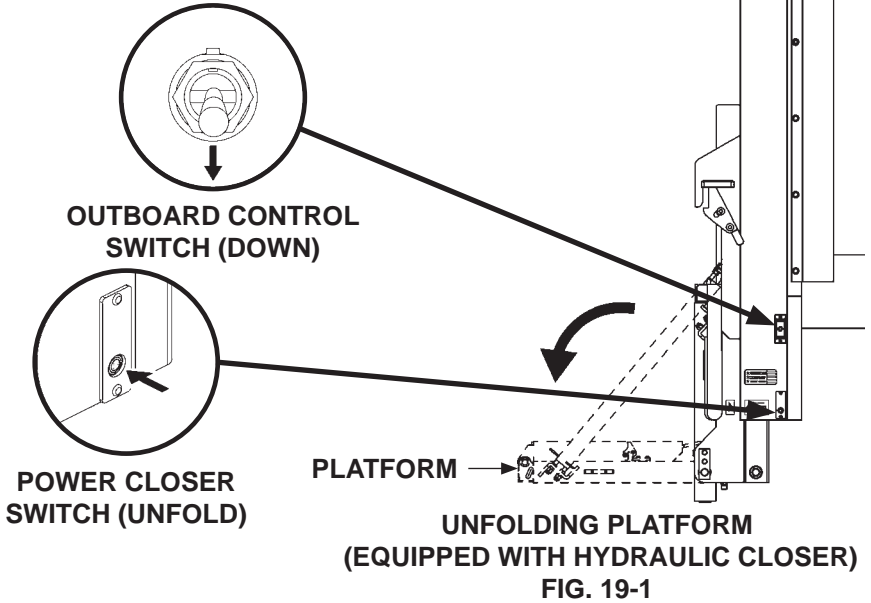

5. Unlock and unfold flipover (if equipped) (**FIG. 19-2**).

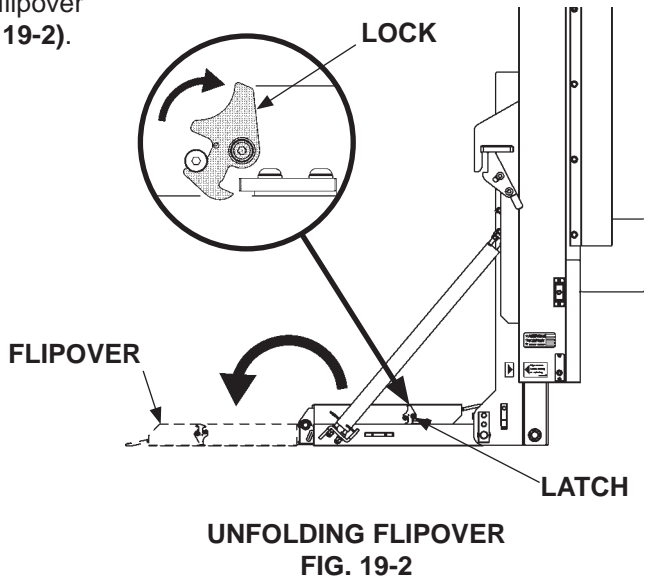

## LOADING VEHICLE - Continued

### LOWERING THE PLATFORM - Continued

Use outboard control switch to lower (**DOWN**) platform (**FIG. 20-1**). Release toggle switch when platform reaches the ground.

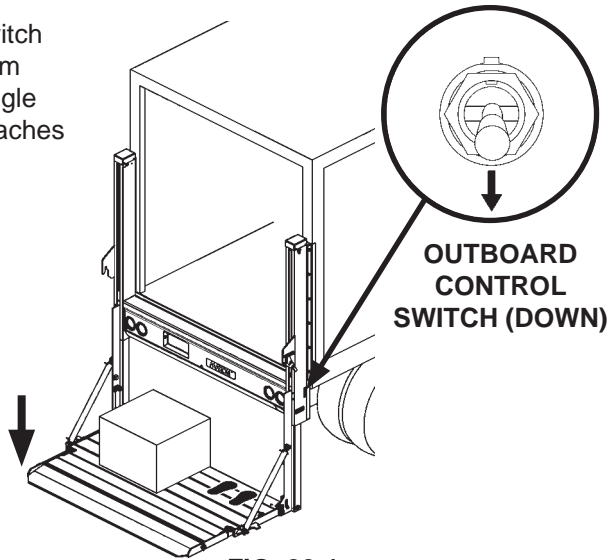

FIG. 20-1

## POSITIONING LOAD

### **⚠ WARNING**

**A load should never extend past the edges of the platform. Do not place unstable loads on platform and do not allow load to exceed lifting capacity of Liftgate. If standing on platform, do not allow your feet to extend beyond inboard edge of platform.**

Place all loads as close as possible to the inboard edge of the platform with heaviest part toward the truck body as shown in **FIG. 20-2**. Move loads across the ramp (**FIG. 20-2**) to the platform, but never rest or raise loads on the ramp. If standing on platform with the load, stand in the footprint area shown and comply with the preceding **WARNING**.

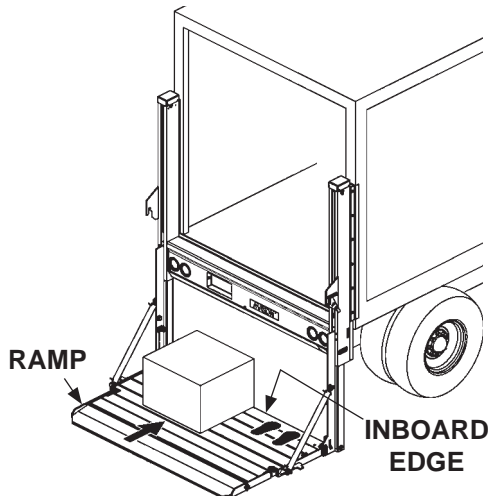

LOADING PLATFORM AT GROUND LEVEL

FIG. 20-2

## RAISING & UNLOADING PLATFORM

### ⚠ CAUTION

A ramp in retention position can trip you when stepping over it. To prevent possible injury, get on the platform before putting the ramp in retention position.

1. Use inboard control switch to raise (**UP**) platform from ground level to bed height (**FIG. 21-1**). Release toggle switch when platform reaches bed height.

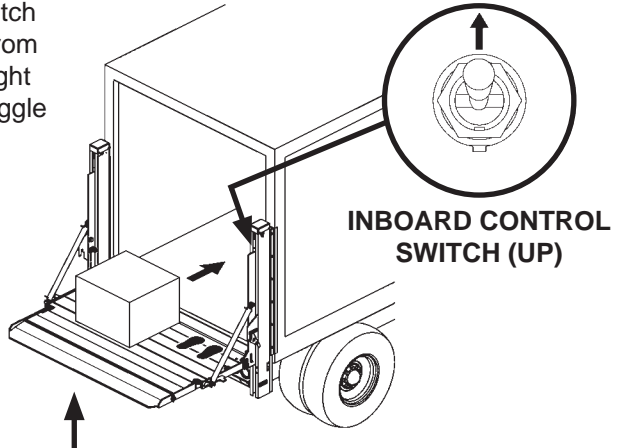

2. Carefully move the load into vehicle (**FIG. 21-1**).

3. Use inboard control switch to lower (**DOWN**) the platform to ground level (**FIG. 21-2**).

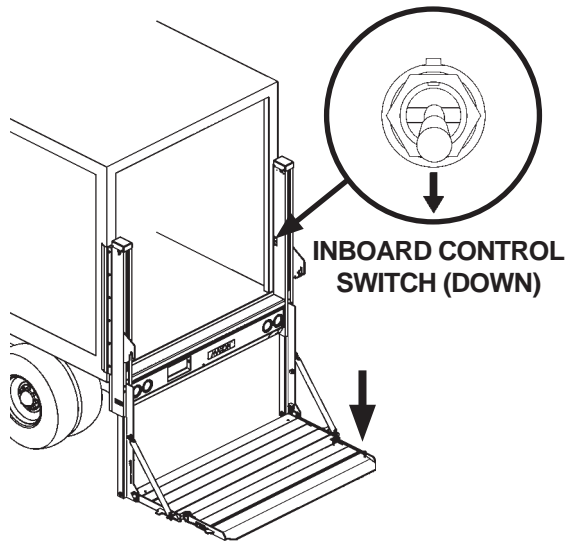

4. If there are more loads to put in vehicle, repeat the previous **LOADING VEHICLE** steps for each load. When loading is finished, use **STOWING PLATFORM** procedure in this manual.

## UNLOADING VEHICLE LOWERING THE PLATFORM

Use inboard control switch to lower (**DOWN**) platform (**FIG. 22-1**). Release toggle switch when platform reaches the ground.

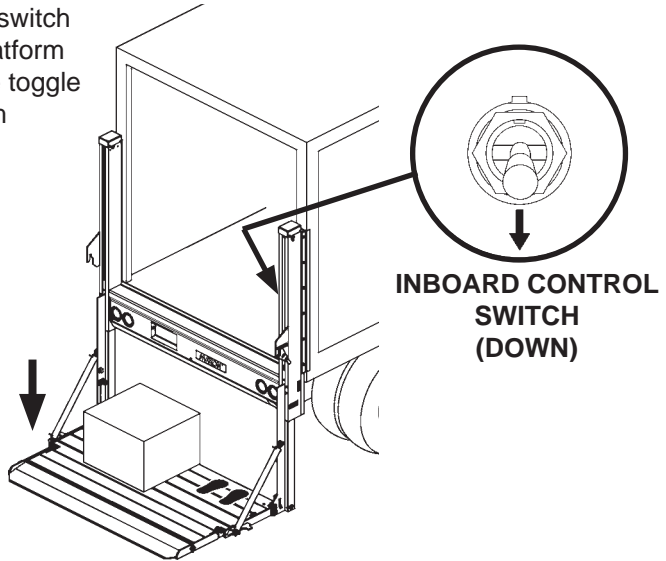

FIG. 22-1

## RAISING THE PLATFORM

Use inboard control switch to raise (**UP**) platform (**FIG. 22-2**) from ground level to bed height. Release toggle switch when platform reaches bed height.

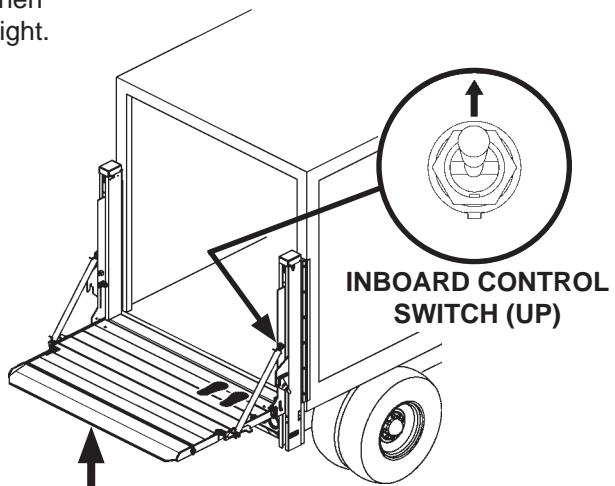

FIG. 22-2

## POSITIONING LOAD

### WARNING

A load should never extend past the edges of the platform. Do not place unstable loads on platform and do not allow load to exceed lifting capacity of Liftgate. If standing on platform, do not allow your feet to extend beyond inboard edge of platform.

### WARNING

Pulling the load from vehicle to platform can result in a fall from platform and serious injury. When unloading vehicle, always push the load out on the platform.

Load the platform at bed level (**FIG. 23-1**) as follows. Push load out of the vehicle to correct position on the platform. Place all loads as close as possible to the inboard edge of the platform with heaviest part toward the vehicle body as shown in **FIG. 23-1**. If standing on platform with the load, stand in the footprint area shown and comply with the **WARNING** at the top of this page.

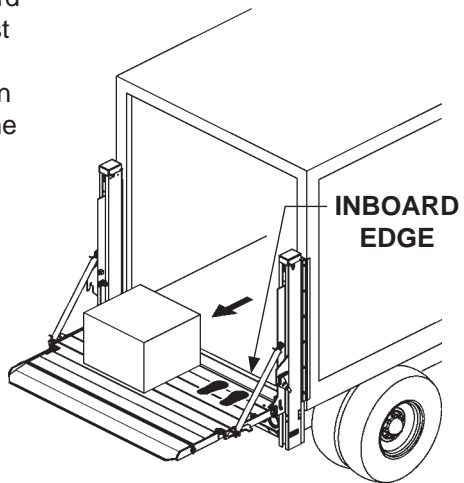

**PUSHING LOAD ON PLATFORM**  
**FIG. 23-1**

# UNLOADING VEHICLE - Continued

## LOWERING & UNLOADING PLATFORM

### **WARNING**

Before lowering platform, make sure area surrounding platform is clear of people and objects. If standing on platform, do not allow your feet to extend beyond inboard edge of platform.

1. Use outboard control switch to lower (**DOWN**) platform to the ground (**FIG. 24-1**). Release toggle switch when platform reaches ground level.

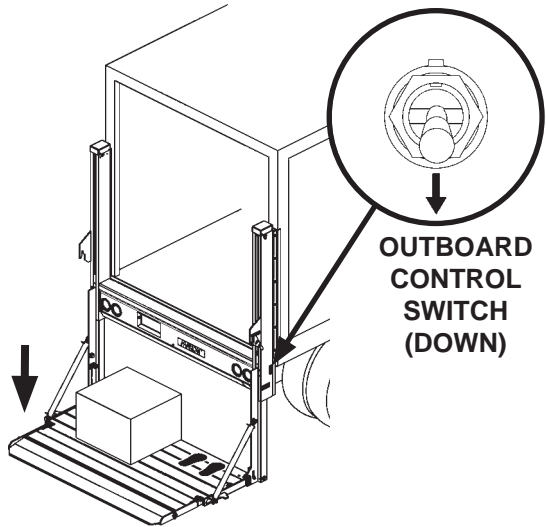

**LOWERING PLATFORM TO  
GROUND LEVEL**  
**FIG. 24-1**

2. Carefully move load off platform (**FIG. 24-2**) and then move it to a place where it will not become a hazard for people and other vehicles. If there is more to unload from vehicle, repeat the previous **UNLOADING VEHICLE** steps for each load. When unloading is finished, use **STOWING PLATFORM** procedure in this manual.

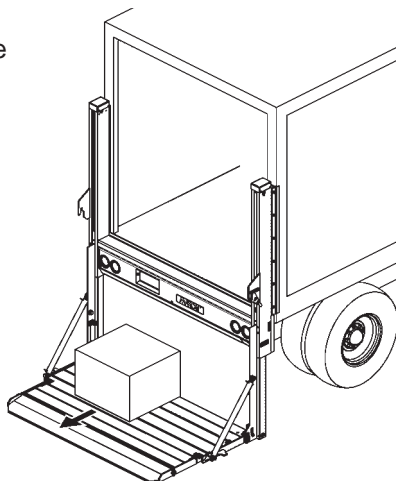

**MOVING LOAD OFF PLATFORM**  
**FIG. 24-2**



# STOWING PLATFORM

**NOTE:** Ensure platform is stowed under hydraulic pressure.

1. Use outboard control switch to raise (**UP**) platform until arrow decals are aligned on runner and column (**FIGS. 25-1 and 25-2**).

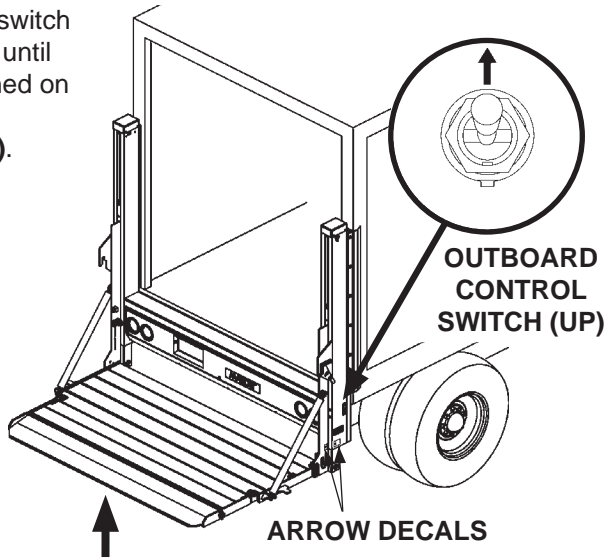

**FIG. 25-1**

2. Fold and lock flipover (if equipped) (**FIG. 25-2**).

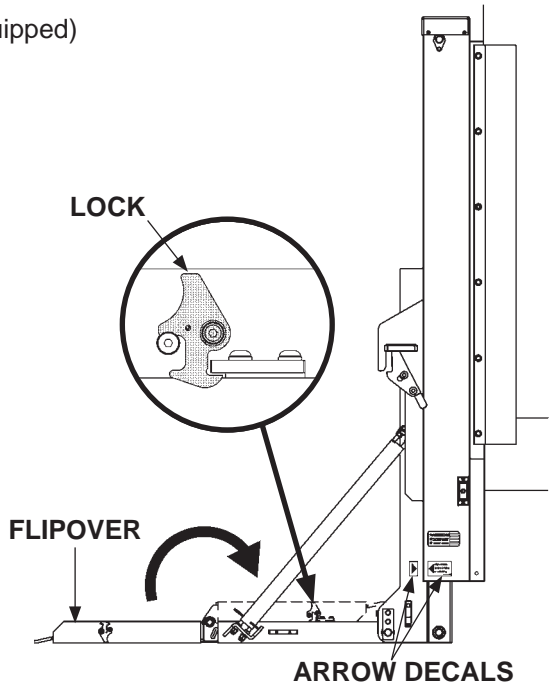
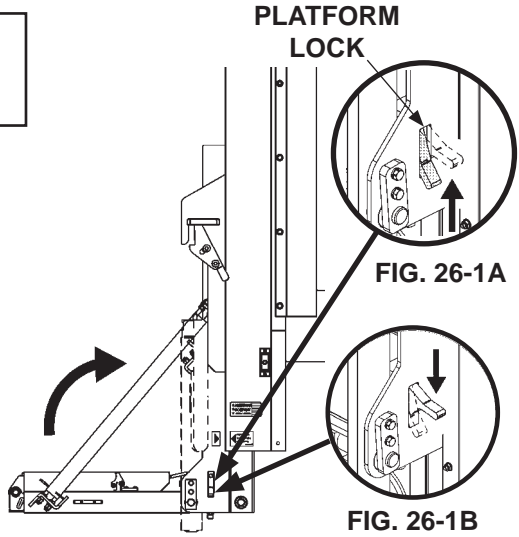

**FIG. 25-2**

# STOWING PLATFORM - Continued

**NOTE:** If liftgate is equipped with hydraulic closer, do step 4.

3. Pull **UP** on platform lock (**FIG. 26-1A**) to unlock platform. Fold platform to stowed position (**FIG. 26-1**). Push platform lock **DOWN** to lock platform (**FIG. 26-1B**).



**FOLDING PLATFORM**  
**FIG. 26-1**

## **CAUTION**

Folding the platform with hydraulic closer requires 2 hands on the controls. This helps prevent injuries.

4. If equipped with hydraulic closer, (**FIG. 26-2**) use one hand for outboard control switch (**UP**) (**FIG. 26-2A**) and one hand for **FOLD/UNFOLD** switch (**FIG. 26-2B**). Activate **FOLD** and **UP** together until platform is folded.

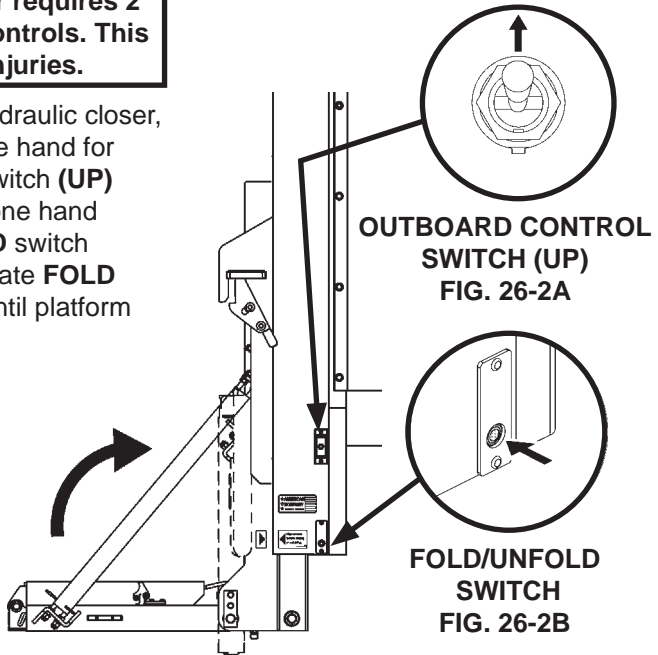

**FOLDING PLATFORM WITH HYDRAULIC CLOSER**  
**FIG. 26-2**

5. Use outboard control switch to raise **(UP)** platform (**FIG. 27-1**) to clear transit hooks (**FIG. 27-1A**). Final platform resting position is shown in **FIG. 27-1B**.

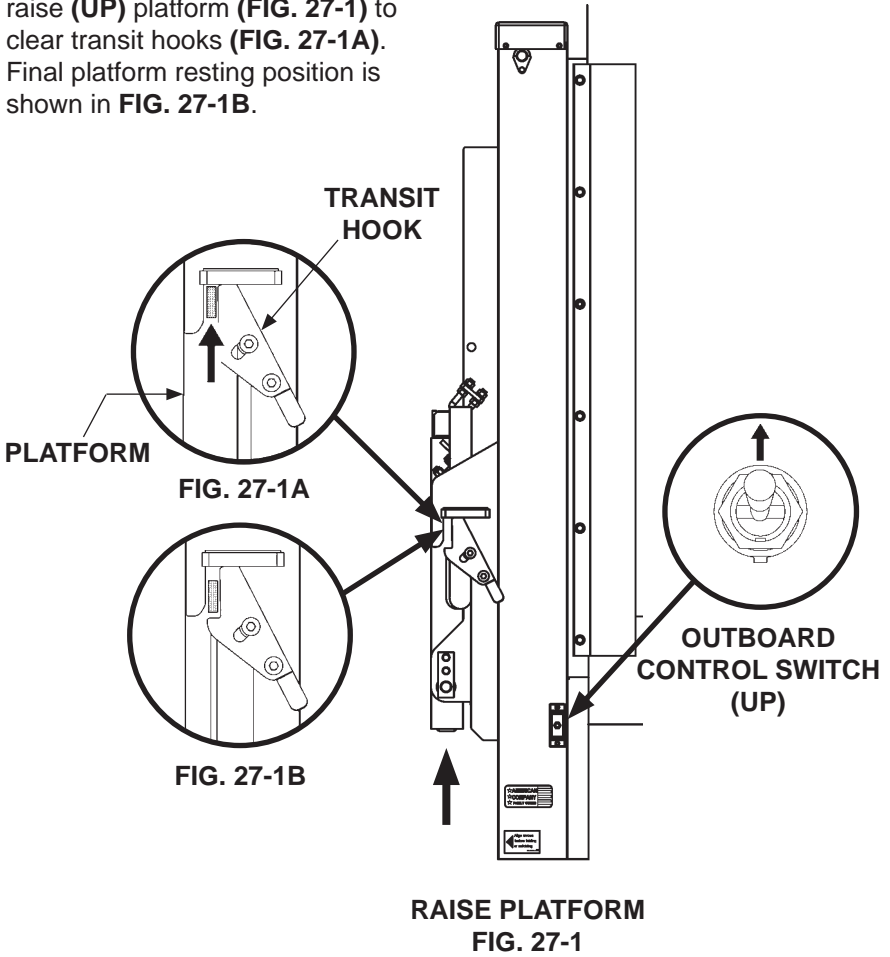

# USING STANDARD CART STOPS (IF EQUIPPED)

## CAUTION

To prevent injuries caused by tripping and falling, make sure cart stops are closed before walking on and off outboard end of platform.

**NOTE:** Some Liftgates are equipped with single or dual cart stops. Cart stops prevent loaded carts from rolling off outboard end of platform. Single cart stops are 1 section, about the same as overall width of platform, and operate with one set of controls. Dual cart stops are 2 identical sections, with a combined width about the same as overall width of platform, and each is independently operated with separate controls (1 set of controls per cart stop). The following procedure shows how to operate dual cart stops; however, a single cart stop operates the same way.

1. Load a platform with cart stops at ground level as follows. Make sure cart stops are closed when loading the platform (**FIGS. 28-1 and 28-2**). Then, move load on the platform as shown in **FIG. 28-1**.

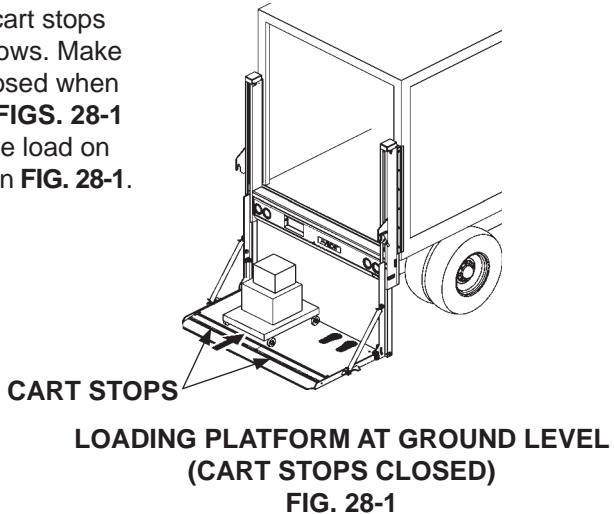

2. To close cart stops, push latch bolt to position shown in **FIG. 28-2**. Step on cart stops and push down into locked position.

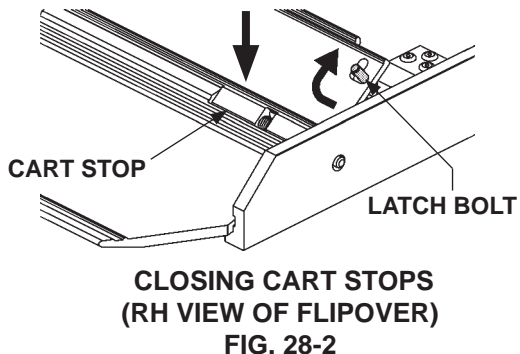

3. To open cart stops, push latch bolt in direction shown in FIG. 29-1.

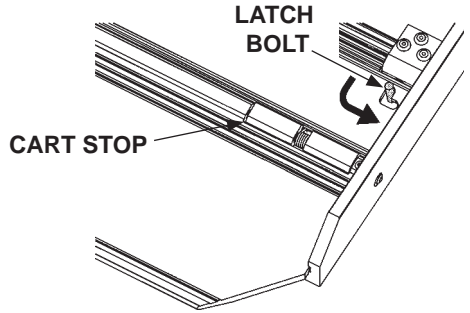

**OPENING CART STOPS  
(RH VIEW OF FLIP OVER)  
FIG. 29-1**

4. Open cart stops (FIGS. 29-1 and 29-2). Next, position cart and stand in the footprint area as shown in FIG. 29-2.

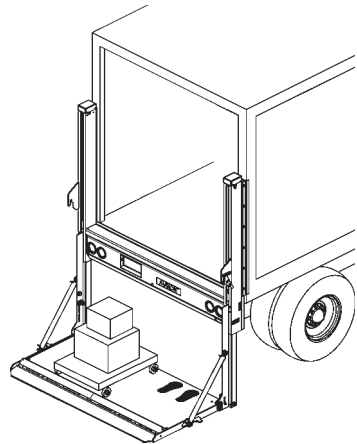

**CART STOPS OPEN  
FIG. 29-2**

5. Raise the platform to bed level (FIG. 29-3). Move the load off the platform into the vehicle body (FIG. 29-3).

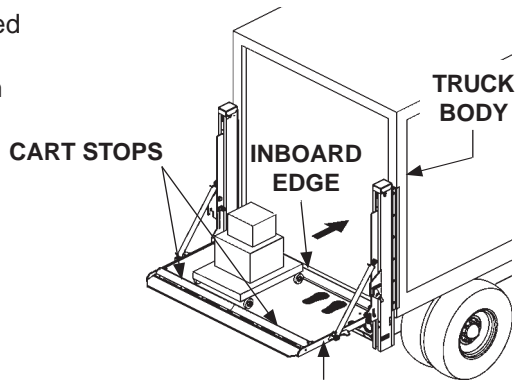

**PLATFORM  
UNLOADING PLATFORM AT BED LEVEL  
FIG. 29-3**

# USING STANDARD CART STOPS (IF EQUIPPED)

- Continued

## WARNING

Pulling the load from vehicle to platform can result in a fall from platform and serious injury. When unloading vehicle, always push the load out on the platform.

6. When loading the platform at bed level, make sure cart stops are open (FIG. 30-1). Push load out of the vehicle to correct position on the platform. Place all loads as close as possible to the inboard edge of the platform with heaviest part toward the truck body as shown in FIG. 30-1. If standing on platform with the load, stand in the footprint area shown and comply with the **WARNING** on page 20.

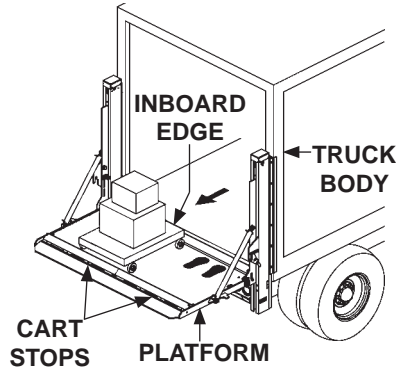

LOADING PLATFORM AT BED LEVEL  
(DUAL CART STOPS OPEN)

FIG. 30-1

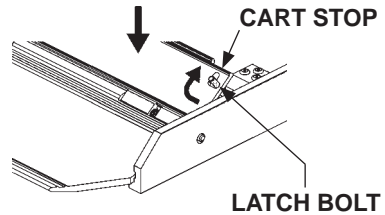

CLOSING CART STOPS  
(RH VIEW OF FLIPOVER)

FIG. 30-2

7. Unload the platform with cart stops at ground level as follows. Make sure cart stops are closed when unloading the platform (FIG. 30-2). Move cart enough to close cart stop. Then, move load off the platform as shown in FIG. 30-3.

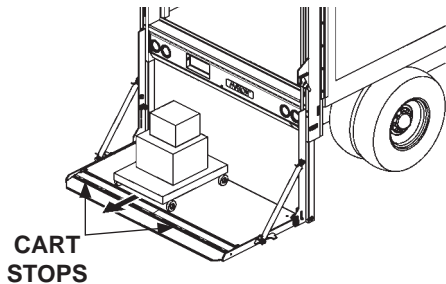

CART STOPS CLOSED

FIG. 30-3

## USING RETENTION RAMP (IF EQUIPPED)

### CAUTION

To prevent injuries caused by tripping and falling, make sure retention ramp is in the ramp position before walking on and off outboard end of platform.

**NOTE:** Some Liftgates are equipped with a retention ramp. A retention ramp, like a cart stop, prevents a load from rolling or sliding off outboard end of platform. Unlike a cart stop, a retention ramp lets you use the entire load surface of platform. The catches on top of the flipover and a cam-like hinge action keep retention ramp stowed when not in use. The cam-like hinge also allows the retention ramp to be rotated and locked in retention position or in ramp position. The following procedure shows how to operate a retention ramp.

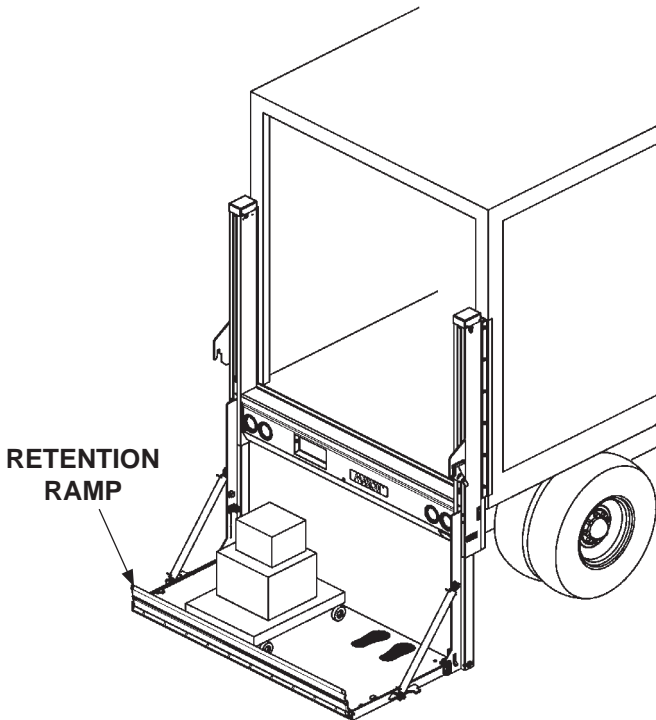

FIG. 31-1

# USING RETENTION RAMP (IF EQUIPPED) - Continued

## CAUTION

To prevent injuries, stay clear of the retention ramp path as it is moved to ramp position. Go to either side of the ramp and stay out of the way.

**NOTE:** To unhook the retention ramp, stand at the RH side of flipover. After the retention ramp is unhooked, the recommended place for handling the retention ramp is at the center of the free edge (**FIG. 32-2**).

### 1. Unhook retention ramp (**FIG. 32-1**).

To release from the catches, pull retention ramp toward outboard end of flipover as shown in **FIG. 32-2**.

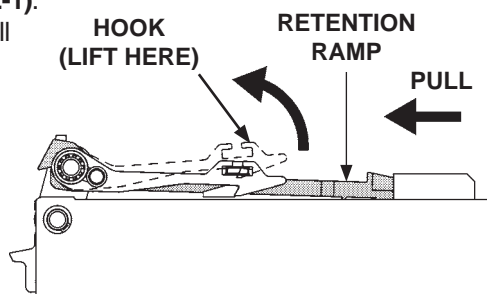

**UNHOOKING RETENTION RAMP  
(RH VIEW OF FLIPOVER)  
FIG. 32-1**

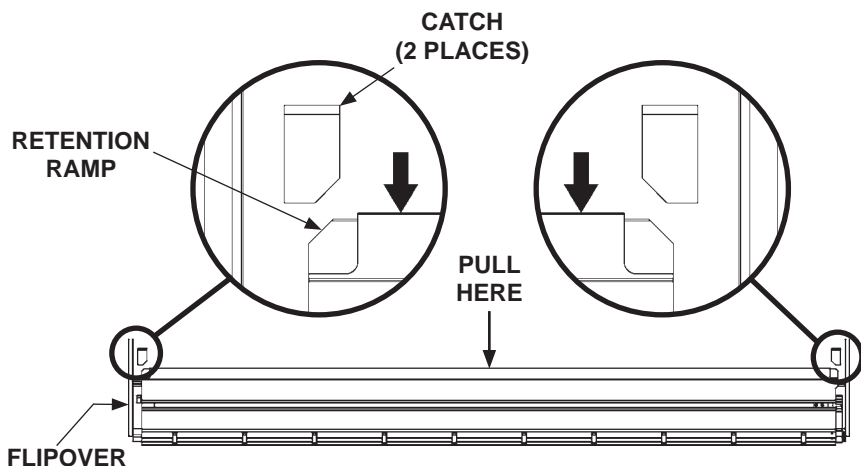

**RELEASING RETENTION RAMP  
(TOP VIEW OF FLIPOVER)  
FIG. 32-2**





## CAUTION

To prevent injuries, stay clear of the retention ramp path as it is moved to ramp position. Go to either side of the ramp and stay out of the way.

2. Continue to pull retention ramp to the retention position (**FIG. 33-1**) and then to ramp position (**FIG. 33-2**).

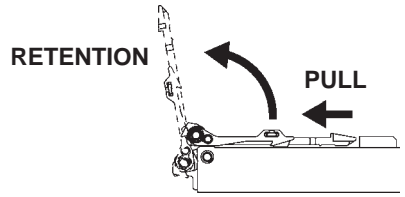

**MOVING TO RETENTION POSITION  
(RH VIEW OF FLIPOVER)**  
**FIG. 33-1**

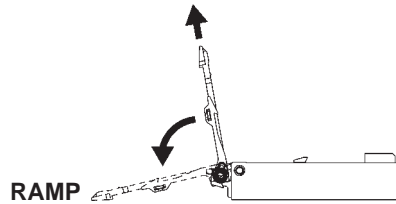

**MOVING TO RAMP POSITION  
(RH VIEW OF FLIPOVER)**  
**FIG. 33-2**

3. When cart is on platform, place the retention ramp in the retention position (**FIGS. 33-3 and 33-4**). Next, stand in the footprint area shown in **FIG. 33-3**.

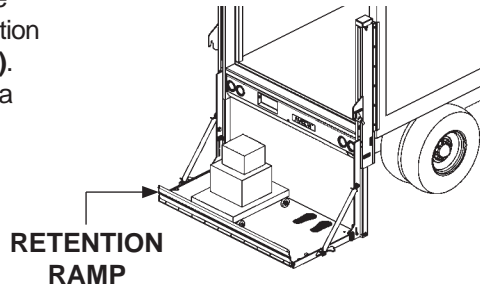

**RAMP IN RETENTION POSITION**  
**FIG. 33-3**

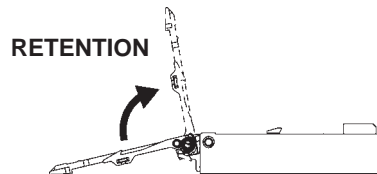

**ROTATING TO RETENTION POSITION  
(RH VIEW OF FLIPOVER)**  
**FIG. 33-4**

# USING RETENTION RAMP (IF EQUIPPED) - Continued

## WARNING

**Pulling the load from vehicle to platform can result in a fall from platform and serious injury. When unloading vehicle, always push the load out on the platform.**

4. When loading the platform at bed level, make sure retention ramp is in the retention position (FIG. 34-1). Push load out of the vehicle to correct position on the platform. Place all loads as close as possible to the inboard edge of the platform with heaviest part toward the truck body as shown in FIG. 34-1. If standing on platform with the load, stand in the footprint area shown and comply with the **WARNING** on page 18.

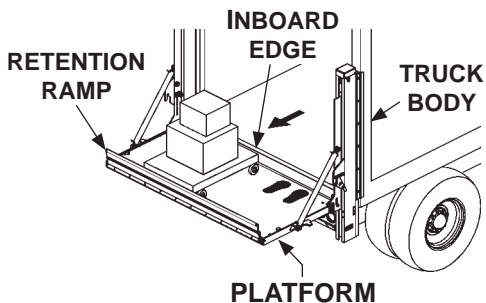

**LOADING PLATFORM AT BED LEVEL  
(RAMP IN RETENTION POSITION)  
FIG. 34-1**

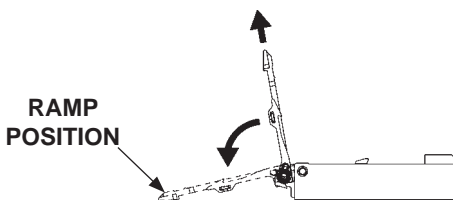

**ROTATING TO RAMP POSITION  
(RH VIEW OF FLIPOVER)  
FIG. 34-2**

5. Unload the platform with retention ramp at ground level as follows. Make sure retention ramp is in the ramp position when unloading the platform (FIG. 34-2). Move cart enough to reposition retention ramp. Then, move load off the platform as shown in FIG. 34-3.

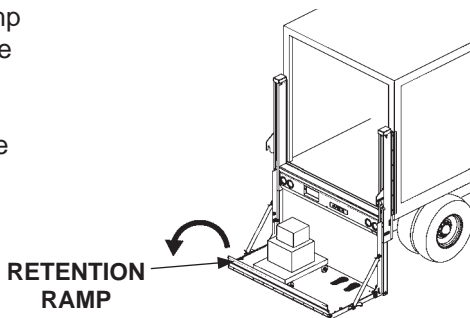

**UNLOADING PLATFORM AT  
GROUND LEVEL (RAMP POSITION)  
FIG. 34-3**

6. To stow, rotate retention ramp to retention position and then to the flat position on flipover as shown in FIG. 35-1.

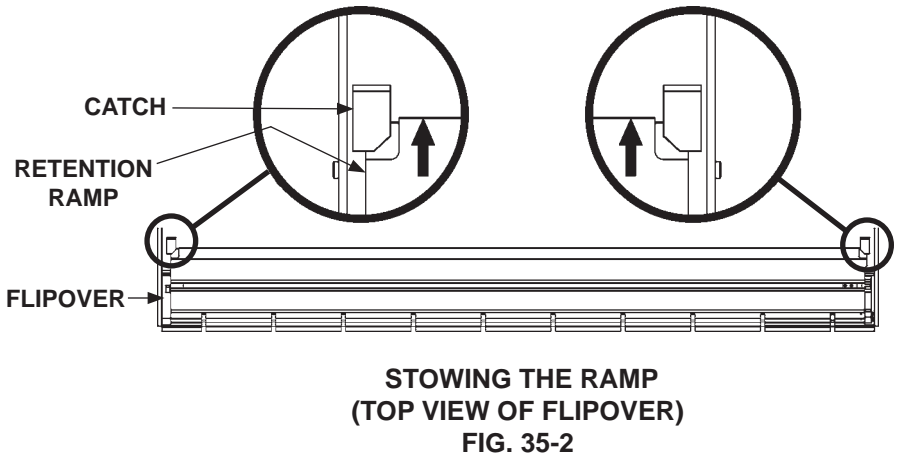
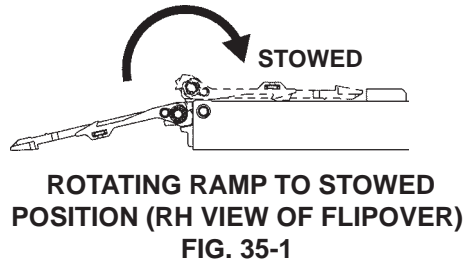

7. Push the retention ramp fully into the catches (FIG. 35-2). Make sure retention ramp is hooked to the flipover (FIG. 35-3).

