

To search for your Maxon parts in this document, press Ctrl + F for Windows or Command + F for macOS to open the Search Box.



This parts manual covers all RA's manufactured **ed** **May 2017 to December 2020**. If your model is older then please contact Maxon CS at 800.227.4116 or parts@maxonlift.com.

TUK-A-WAY® TE-25/30

PARTS BREAKDOWN



EXTENSION PLATE ASSEMBLY

- BOLT ON
- WELD ON

STEP KITS

- DUAL
- SINGLE
- FLEXIBLE

PLEASE REFER TO THE
MAXON PARTS PORTAL:
TUK-A-WAY > OPTIONS

MAIN ASSEMBLY

- PAINTED
 - WITH SINGLE TORSION SPRING
 - WITH DUAL TORSION SPRINGS
- GALVANIZED
 - WITH SINGLE TORSION SPRING
 - WITH DUAL TORSION SPRINGS

PUMP BOX

- HYDRAULIC SYSTEMS
 - GRAVITY DOWN
 - POWER DOWN
- PUMP COVER AND MOUNTING
PLATE ASSEMBLY
 - GRAVITY DOWN 12V
 - GRAVITY DOWN 24V
 - POWER DOWN

STEEL PLATFORM AND
FLIPOVER ASSEMBLY

- WITHOUT TORSION BAR
- WITH TORSION BAR

STEEL PLATFORM AND
ALUMINUM FLIPOVER ASSEMBLY

ALUMINUM PLATFORM AND
FLIPOVER ASSEMBLY

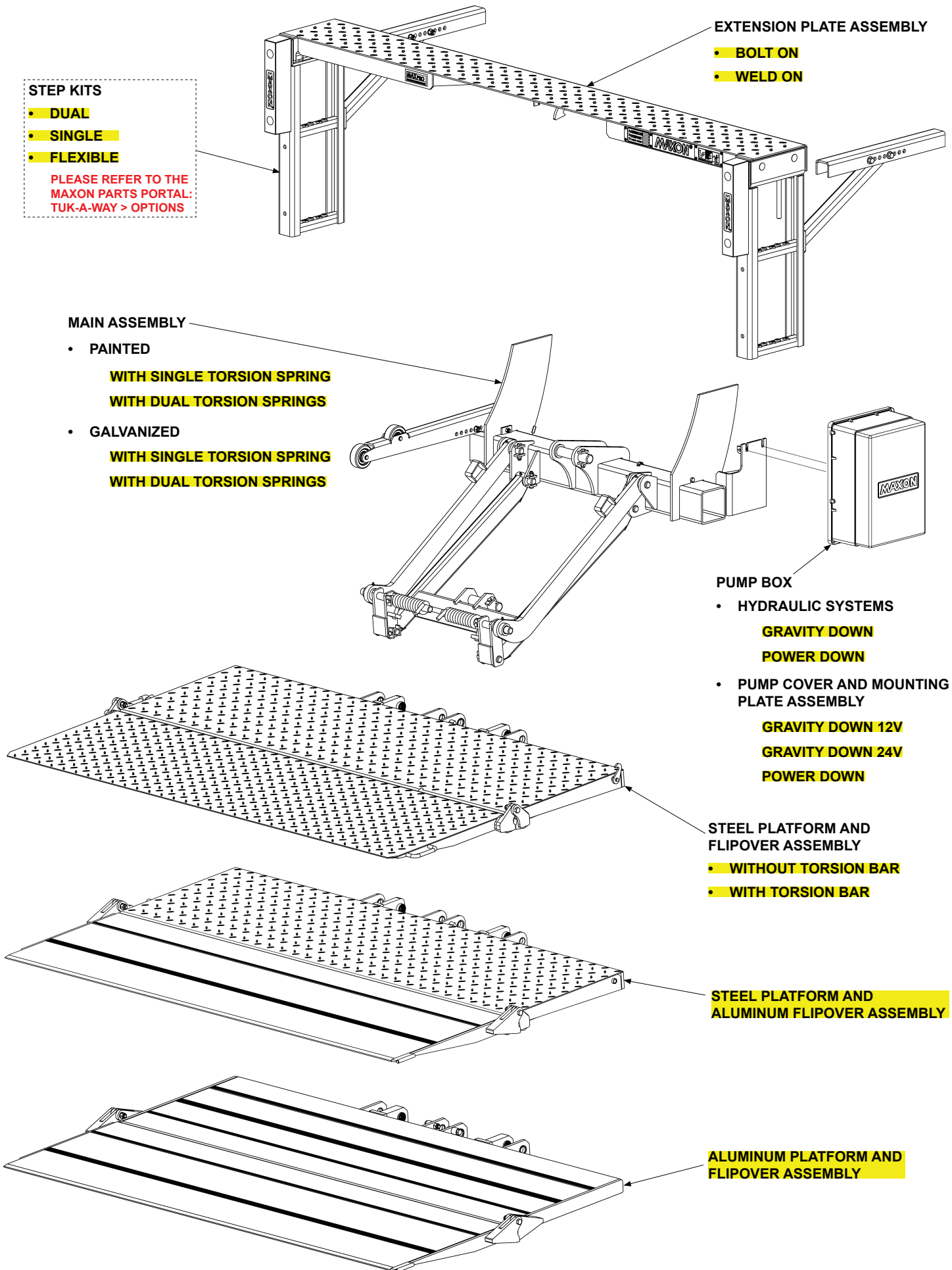

EXTENSION PLATE ASSEMBLY (BOLT ON)

LAST UPDATED
MAY 2017 to DEC 2020

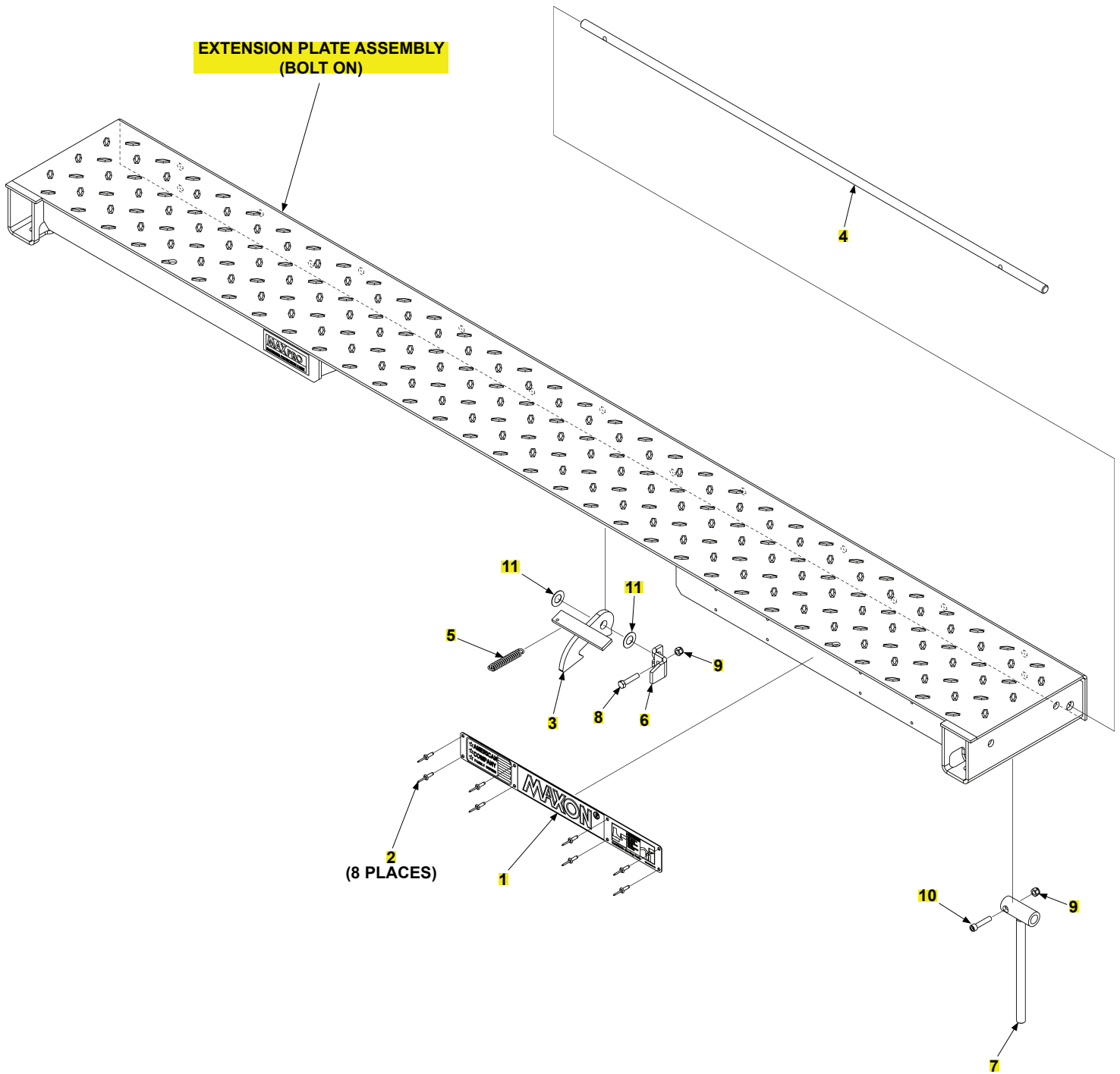

EXTENSION PLATE ASSEMBLY (BOLT ON)

LAST UPDATED
MAY 2017 to DEC 2020

ITEM	QTY.	PART NO.	DESCRIPTION
REF	1	297260-01	EXT PL ASSY,STD TUKS,96",BOLT ON
		297260-01G	EXT PL ASSY,STD TUKS,96",BOLT ON,G
		297260-02	EXT PL ASSY,STD TUKS,102",BOLT ON
		297260-02G	EXT PL ASSY,STD TUKS,102",BOLT ON,G
1	1	280004-01	PLATE, MAXON NAME & DECALS
2	8	904005-2	RIVET,BLIND SSTL DOME.187X.565
3	1	298168-01	SAFETY HOOK WLDM'T
4	1	297256-01	BAR,HOOK RELEASE,46" LG
		297256-02	BAR,HOOK RELEASE,49" LG
5	1	215345	SPRING, EXTENTION, .093 X 2.50
6	1	297768-01	BRKT LEVER
7	1	297769-01	HANDLE WLDM'T
8	1	900009-6	SCREW, CAP .31-18X1.5 G8 ZC
9	2	901001	NUT,NYLON 5/16-18 ZINC
10	1	900726-08	SCREW, SOC HD CAP, .312 X 1.5
11	2	902000-17	WASHER, FLAT .625 .032 THK

EXTENSION PLATE ASSEMBLY (WELD ON)

LAST UPDATED
MAY 2017 to DEC 2020

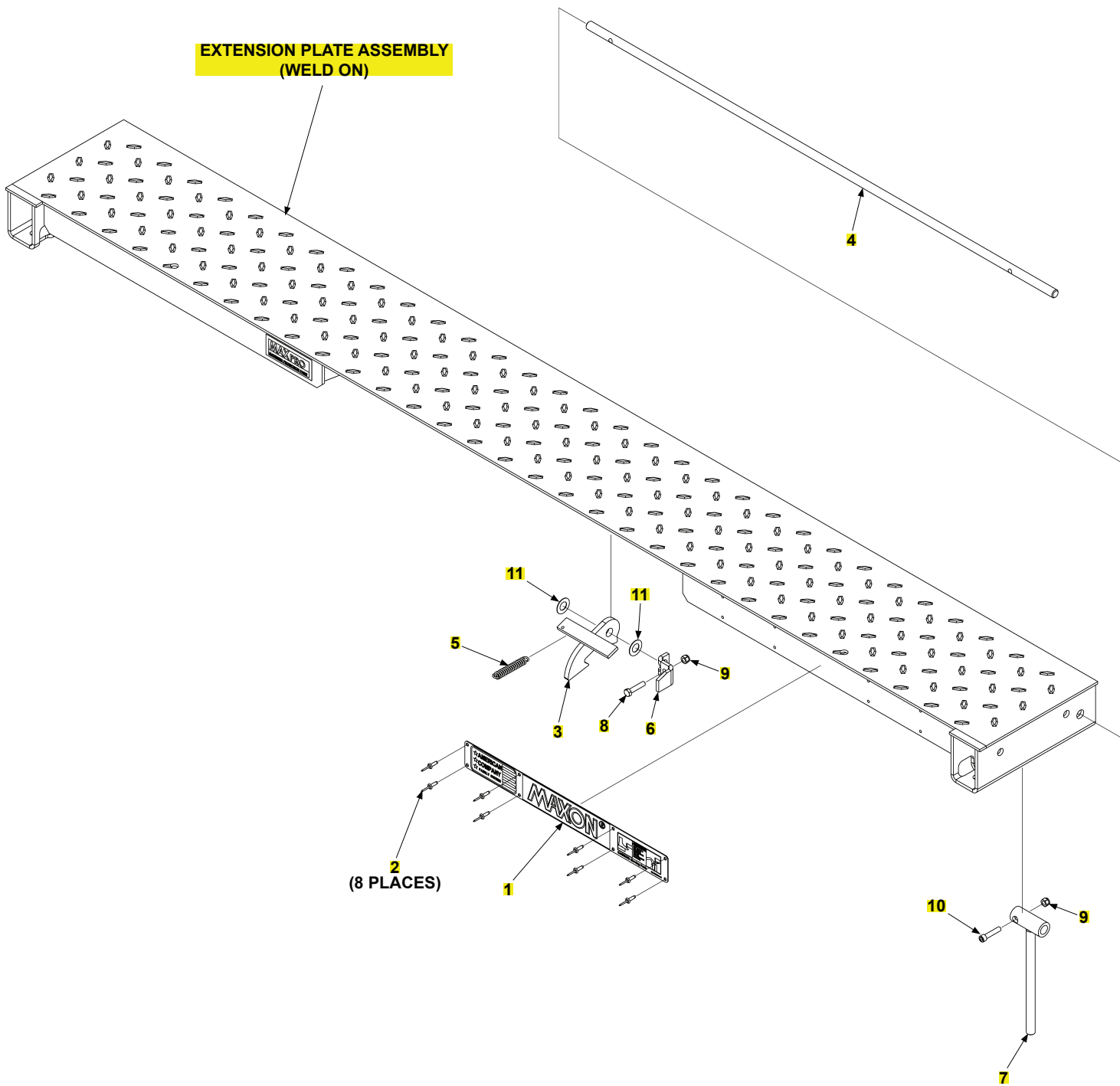

EXTENSION PLATE ASSEMBLY (WELD ON)**LAST UPDATED
MAY 2017 to DEC 2020**

ITEM	QTY.	PART NO.	DESCRIPTION
REF	1	297264-01	EXT PL ASSY,STD TUKS,96",WELD ON
		297264-02	EXT PL ASSY,STD TUKS,102",WELD ON
1	1	280004-01	PLATE, MAXON NAME & DECALS
2	8	904005-2	RIVET,BLIND SSTL DOME.187X.565
3	1	298168-01	SAFETY HOOK WLDM'T
4	1	297256-01	BAR,HOOK RELEASE,46" LG
		297256-02	BAR,HOOK RELEASE,49" LG
5	1	215345	SPRING, EXTENTION, .093 X 2.50
6	1	297768-01	BRKT LEVER
7	1	297769-01	HANDLE WLDM'T
8	1	900009-6	SCREW, CAP .31-18X1.5 G8 ZC
9	2	901001	NUT,NYLON 5/16-18 ZINC
10	1	900726-08	SCREW, SOC HD CAP, .312 X 1.5
11	2	902000-17	WASHER, FLAT .625 .032 THK

TE-25/30 MAIN ASSEMBLY PAINTED WITH SINGLE TORSION SPRING

LAST UPDATED
MAY 2017 to DEC 2020

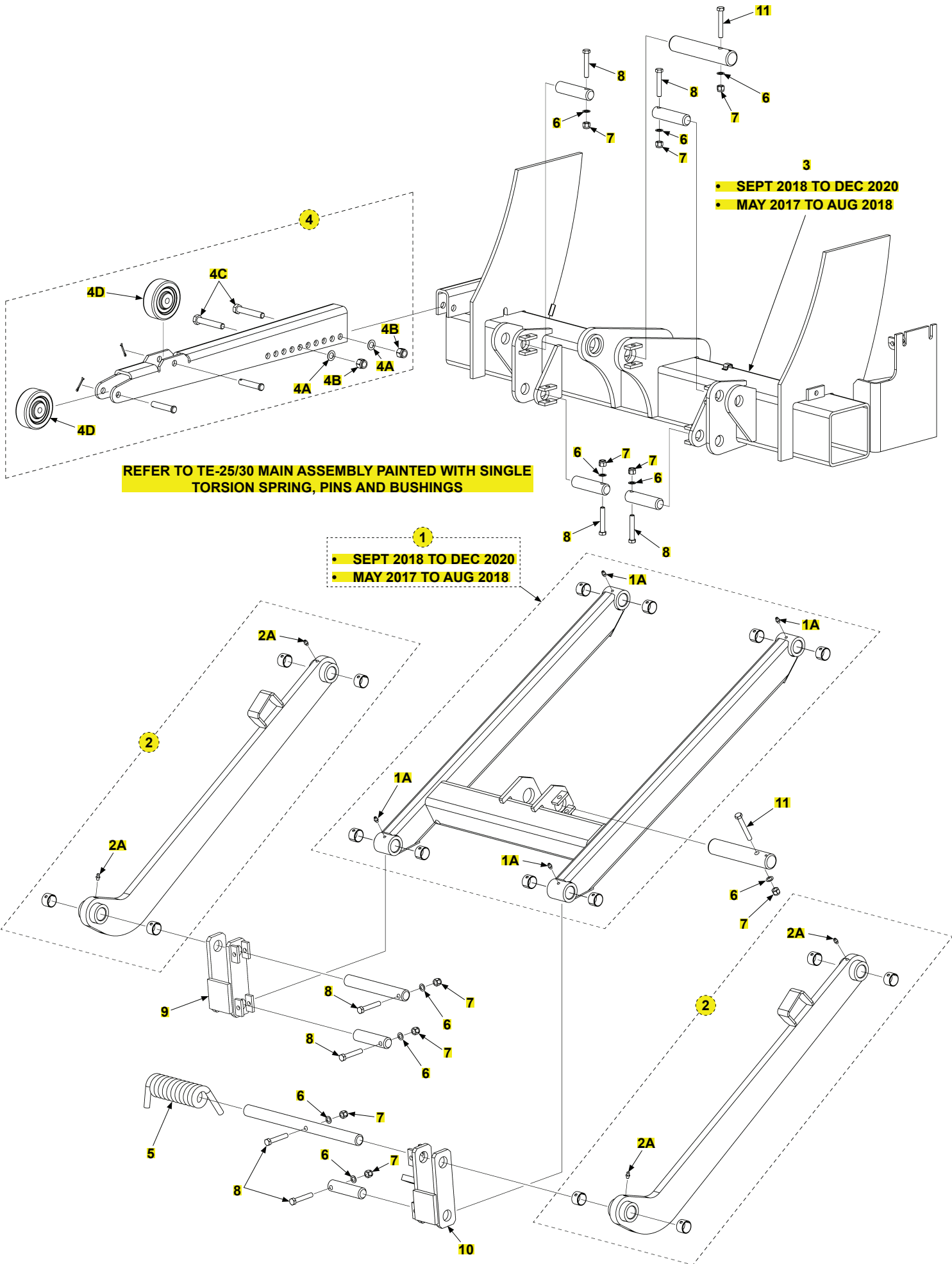

TE-25/30 MAIN ASSEMBLY PAINTED WITH SINGLE TORSION SPRING

LAST UPDATED
MAY 2017 to DEC 2020

ITEM	QTY.	PART NO.	DESCRIPTION
1	1	298073-01	LIFT FRAME ASSY, GAL (SEPT 2018 TO DEC 2020)
		286009-01	LIFT FRAME ASSY (MAY 2017 TO AUG 2018)
1A	4	224342	FITTING, GREASE 1/4"SELF DRILL
2	2	286007-01	PARALLEL ARM ASSY
2A	4	224342	FITTING, GREASE 1/4"SELF DRILL
3	1	298083-01	M/F ASSY,WELD ON PAINTED MNT PL' (SEPT 2018 TO DEC 2020)
		269620-01	M/F ASSY, 38.0 MNT PL, BOLTED (MAY 2017 TO AUG 2018)
4	1	287060-01	KIT, OPENER, TUK-A-WAY
4A	2	902000-13	WASHER, FLAT .500 .032 THK
4B	2	901010	NUT, NYLON LOCK 1/2-13 ZC
4C	2	900035-9	SCREW,CAP HXHD.5-13UNC-2A 3.00
4D	2	280082-01	ROLLER, OPENER,3.5 X 1.25 X .5
5	1	286038-01	TORSION SPRING, RH HELIX
6	10	902000-9	WASHER, FLAT.375X.032 THK
7	10	901002	NUT, NYLON 3/8-16 ZINC
8	8	900014-9	SCREW,HEX CAP.38-16X2.25,G8,ZC
9	1	296872-10	SHACKLE WLDMT,LB/HB,LH,5.00,NO SPRG BRKT
		296872-09	SHACKLE WLDMT,HB,LH,4.63,NO SPRG BRKT
10	1	296872-04	SHACKLE WLDMT,LB/HB,RH,5.00
		296872-02	SHACKLE WLDMT,HB,RH,4.63
11	2	900014-18	SCREW,HEX CAP.38-16X2.75,G8,ZC

TE-25/30 MAIN ASSEMBLY PAINTED WITH SINGLE TORSION SPRING, PINS AND BUSHINGS

LAST UPDATED
MAY 2017 to DEC 2020

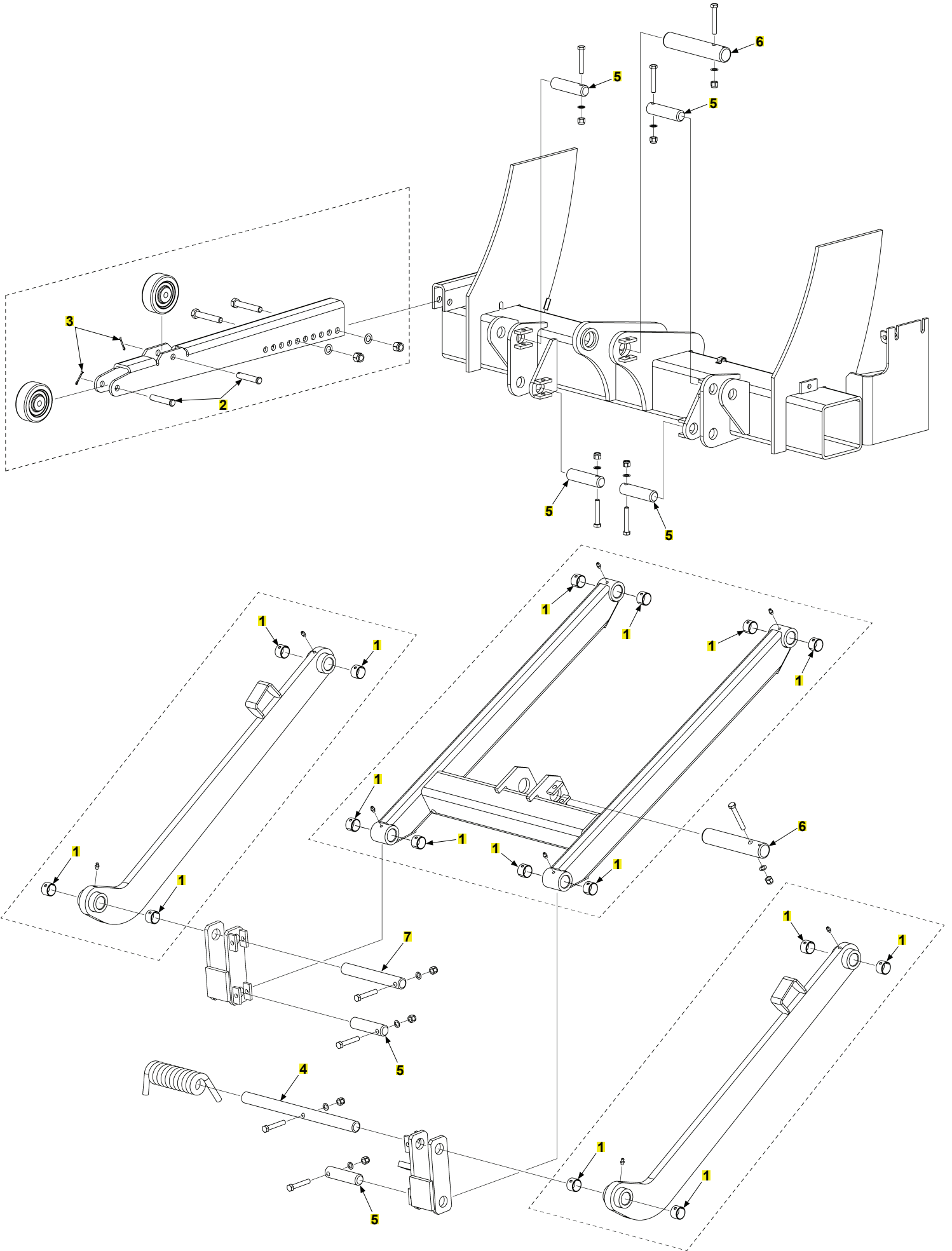

TE-25/30 MAIN ASSEMBLY PAINTED WITH SINGLE TORSION SPRING, PINS AND BUSHINGS**LAST UPDATED
MAY 2017 to DEC 2020**

ITEM	QTY.	PART NO.	DESCRIPTION
1	16	260916-08	BEARING,SELF LUBE 1"DIA X .75"
2	2	905202-03	PIN CLEVIS, .500 DIA X 2.50
3	2	030805	COTTER PIN 1/8 X 1"
4	1	262981	PIN 1"DIA X 14.00"LG
5	6	252686	PIN 1"DIA. 4.00"LG
6	2	286074-01	PIN, CYLINDER
7	1	260830	PIN 1"DIA X 7.25"LG

TE-25/30 MAIN ASSEMBLY GALVANIZED WITH SINGLE TORSION SPRING

LAST UPDATED
MAY 2017 to DEC 2020

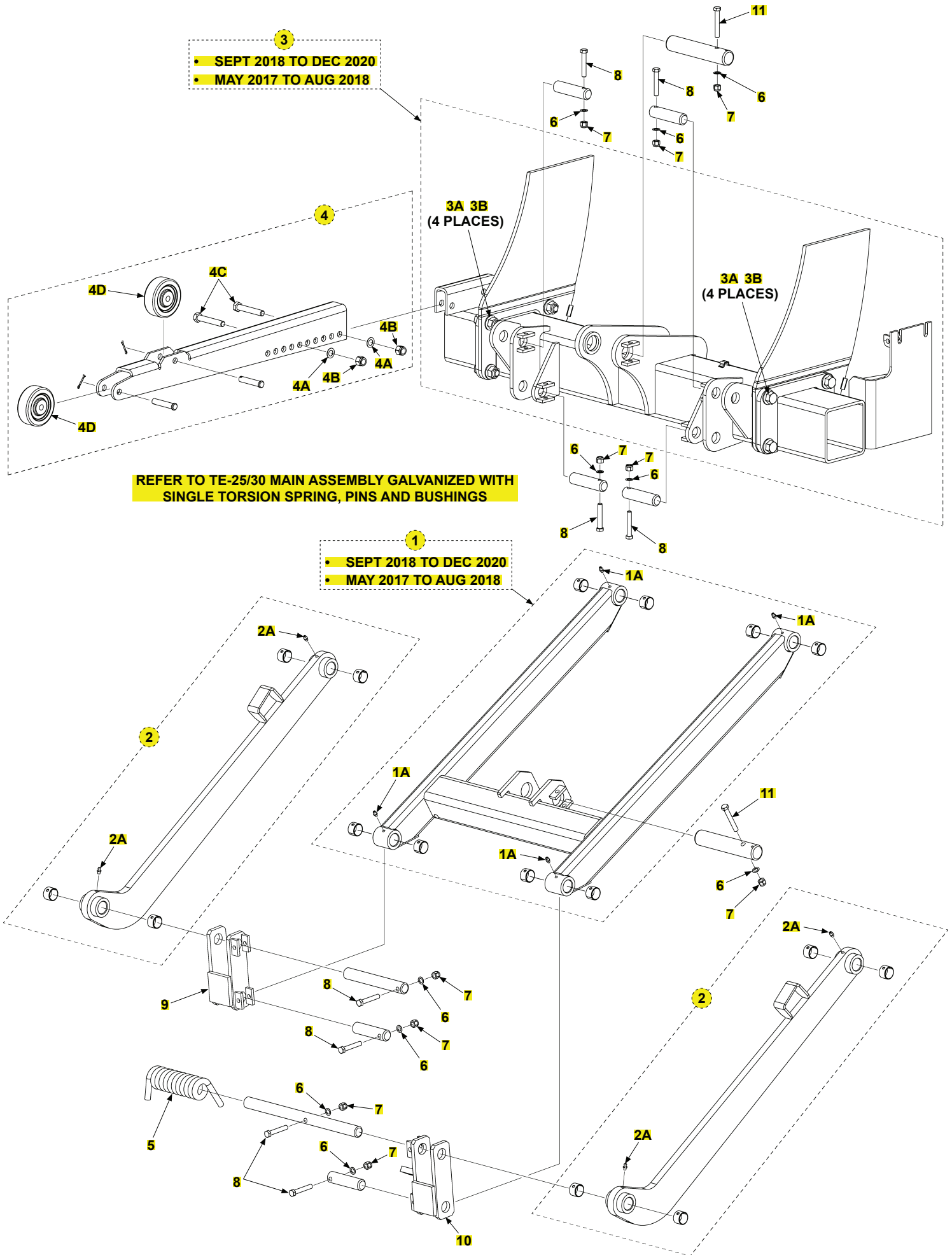

TE-25/30 MAIN ASSEMBLY GALVANIZED WITH SINGLE TORSION SPRING

LAST UPDATED
MAY 2017 to DEC 2020

ITEM	QTY.	PART NO.	DESCRIPTION
1	1	298073-01G	LIFT FRAME ASSY, GAL (SEPT 2018 TO DEC 2020)
		286009-01G	LIFT FRAME ASSY, GAL (MAY 2017 TO AUG 2018)
1A	4	224342	FITTING, GREASE 1/4"SELF DRILL
2	2	286007-01G	PARALLEL ARM ASSY,GAL
2A	4	224342	FITTING, GREASE 1/4"SELF DRILL
3	1	298084-01G	M/F ASSY,BOLTED,34.25 & 33.75 MNT,G (SEPT 2018 TO DEC 2020)
		296868-01G	M/F ASSY, BOLTED, 34.25 & 33.75 MNT, G (MAY 2017 TO AUG 2018)
3A	8	901023-04	FLANGE LOCK NUT,63-11,ZC
3B	8	901615-03	BOLT HEX FRAME .63-11X1.75"LG
4	1	287060-01G	KIT, OPENER, TUK-A-WAY, GALV
4A	2	902000-13	WASHER, FLAT .500 .032 THK
4B	2	901010	NUT, NYLON LOCK 1/2-13 ZC
4C	2	900035-9	SCREW,CAP HXHD.5-13UNC-2A 3.00
4D	2	280082-01	ROLLER, OPENER,3.5 X 1.25 X .5
5	1	286038-01	TORSION SPRING, RH HELIX
6	10	902000-9	WASHER, FLAT.375X.032 THK
7	10	901002	NUT, NYLON 3/8-16 ZINC
8	8	900014-9	SCREW,HEX CAP.38-16X2.25,G8,ZC
9	1	296872-10G	SHACKLE WLDM'T,HB/LB,LH,5.00,NO SPRG BRKT,G
		296872-09G	SHACKLE WLDMT,HB,LH,4.63,NO SPRG BRKT,G
10	1	296872-04G	SHACKLE WLDM'T,HB/LB,RH,5.00,G
		296872-02G	SHACKLE WLDMT,HB,RH,4.63,GAL
11	2	900014-18	SCREW,HEX CAP.38-16X2.75,G8,ZC

TE-25/30 MAIN ASSEMBLY GALVANIZED WITH SINGLE TORSION SPRING, PINS AND BUSHINGS

LAST UPDATED
MAY 2017 to DEC 2020

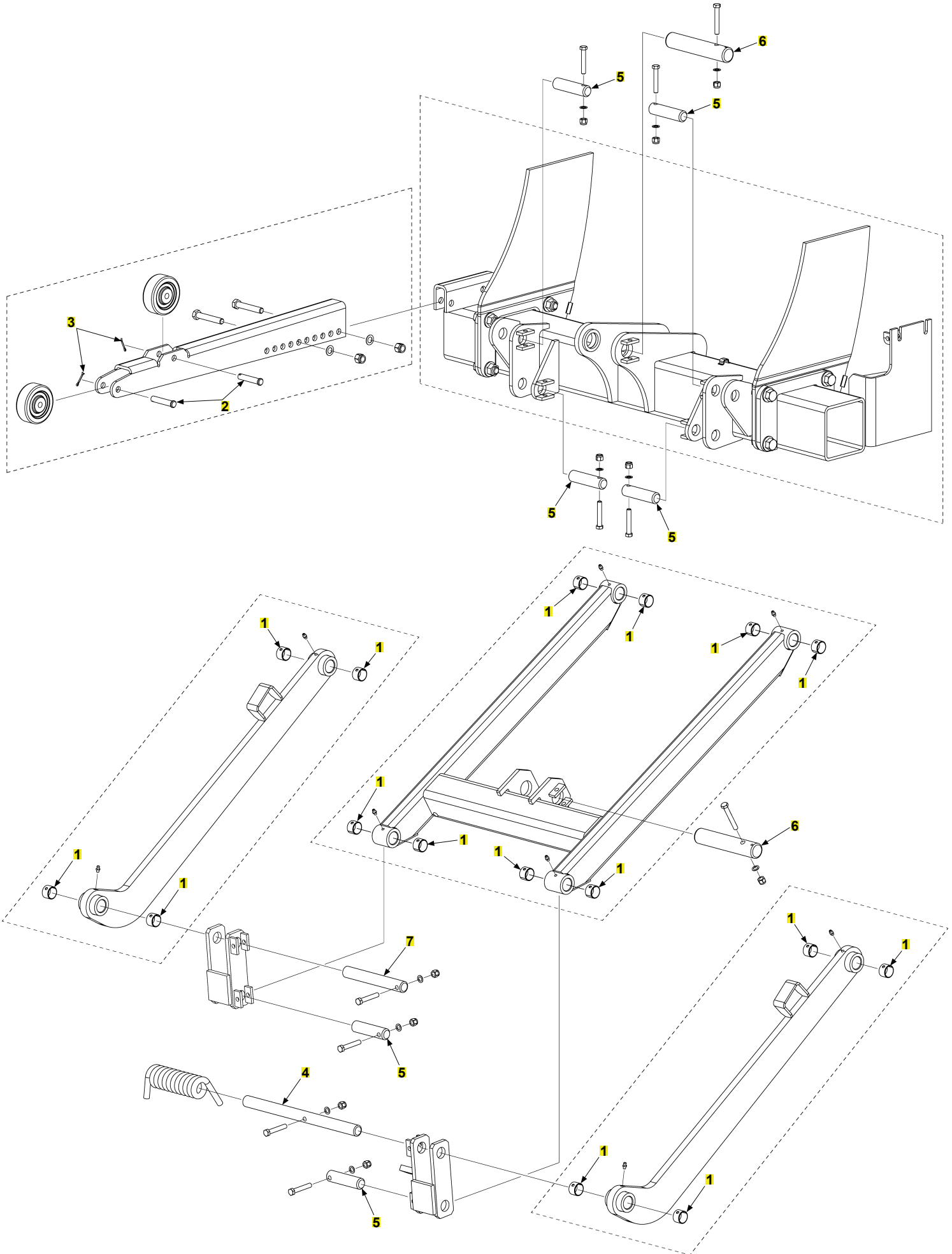

TE-25/30 MAIN ASSEMBLY GALVANIZED WITH SINGLE TORSION SPRING, PINS AND BUSHINGS**LAST UPDATED
MAY 2017 to DEC 2020**

ITEM	QTY.	PART NO.	DESCRIPTION
1	16	260916-08	BEARING,SELF LUBE 1"DIA X .75"
2	2	905202-03	PIN CLEVIS, .500 DIA X 2.50
3	2	030805	COTTER PIN 1/8 X 1"
4	1	262981	PIN 1"DIA X 14.00"LG
5	6	252686	PIN 1"DIA. 4.00"LG
6	2	286074-01	PIN, CYLINDER
7	1	260830	PIN 1"DIA X 7.25"LG

TE-25/30 MAIN ASSEMBLY PAINTED WITH DUAL TORSION SPRINGS

LAST UPDATED
MAY 2017 to DEC 2020

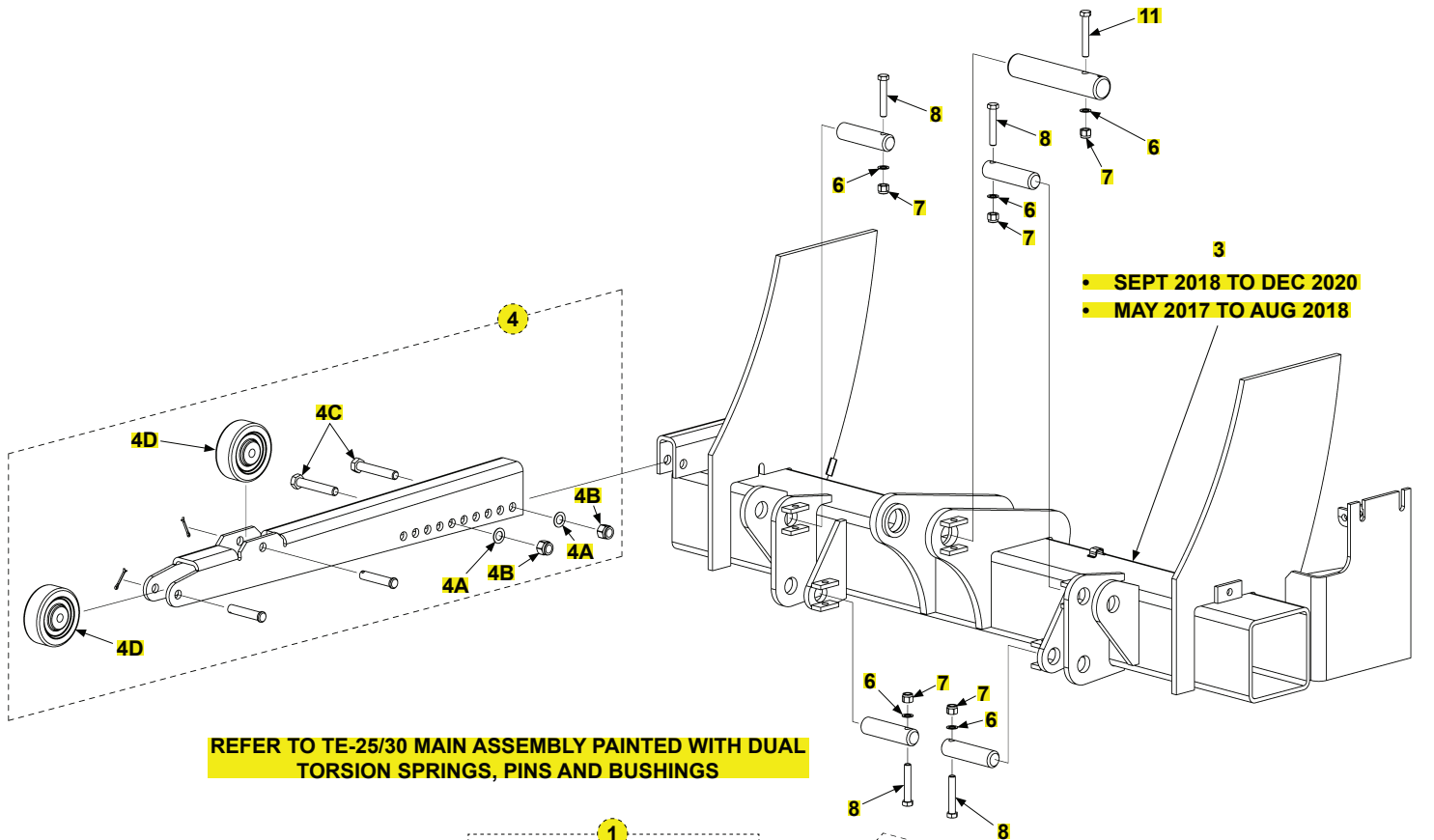

• SEPT 2018 TO DEC 2020
• MAY 2017 TO AUG 2018

REFER TO TE-25/30 MAIN ASSEMBLY PAINTED WITH DUAL TORSION SPRINGS, PINS AND BUSHINGS

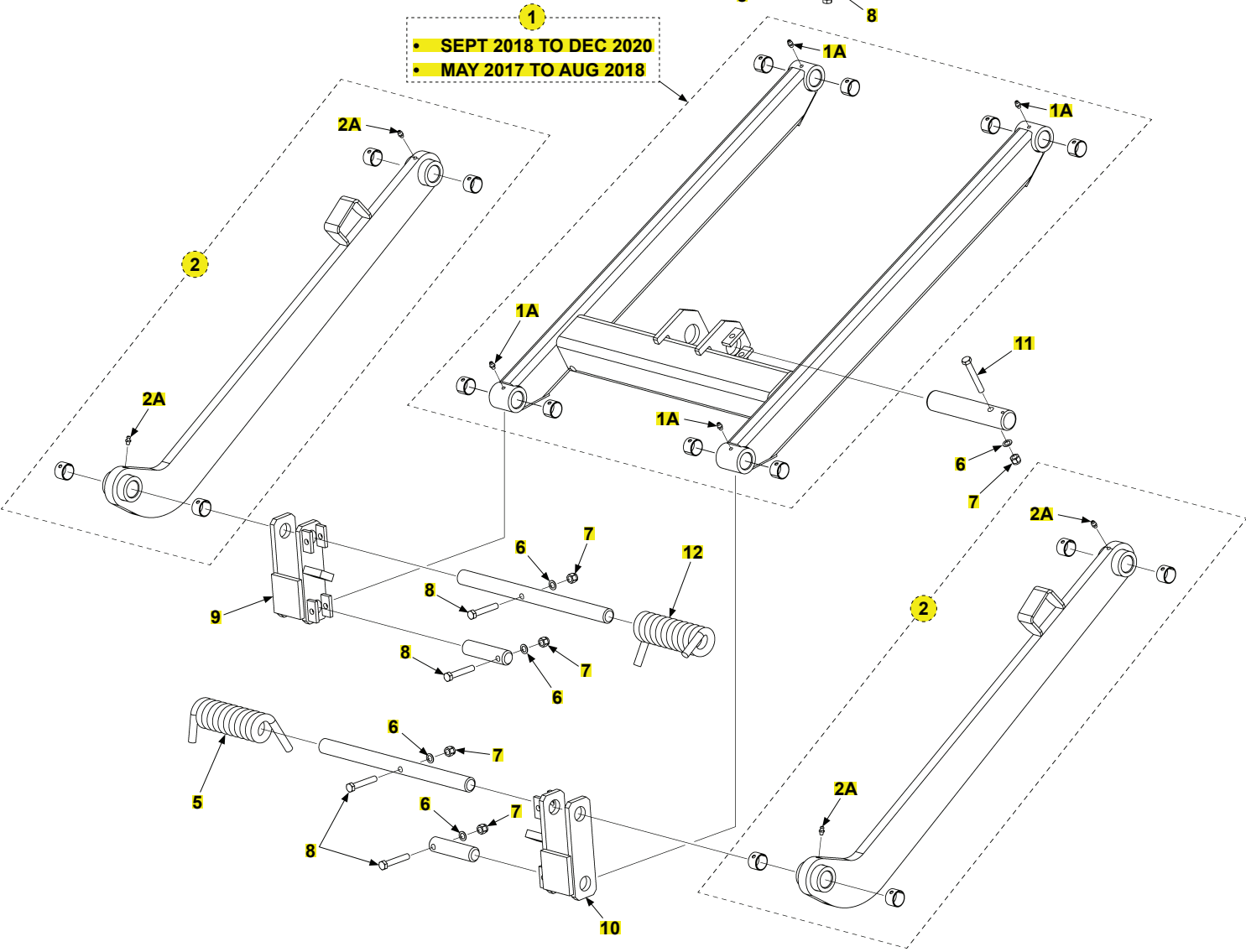

• SEPT 2018 TO DEC 2020
• MAY 2017 TO AUG 2018

TE-25/30 MAIN ASSEMBLY PAINTED WITH DUAL TORSION SPRINGS

LAST UPDATED
MAY 2017 to DEC 2020

ITEM	QTY.	PART NO.	DESCRIPTION
1	1	298073-01	LIFT FRAME ASSY (SEPT 2018 TO DEC 2020)
		286009-01	LIFT FRAME ASSY (MAY 2017 TO AUG 2018)
1A	4	224342	FITTING, GREASE 1/4"SELF DRILL
2	2	286007-01	PARALLEL ARM ASSY
2A	4	224342	FITTING, GREASE 1/4"SELF DRILL
3	1	298083-01	M/F ASSY,WELD ON PAINTED MNT PL'S (SEPT 2018 TO DEC 2020)
		269620-01	M/F ASSY, 38.0 MNT PL, BOLTED (MAY 2017 TO AUG 2018)
4	1	287060-01	KIT, OPENER, TUK-A-WAY
4A	2	902000-13	WASHER, FLAT .500 .032 THK
4B	2	901010	NUT, NYLON LOCK 1/2-13 ZC
4C	2	900035-9	SCREW,CAP HXHD.5-13UNC-2A 3.00
4D	2	280082-01	ROLLER, OPENER,3.5 X 1.25 X .5
5	1	286038-01	TORSION SPRING, RH HELIX
6	10	902000-9	WASHER, FLAT.375X.032 THK
7	10	901002	NUT, NYLON 3/8-16 ZINC
8	8	900014-9	SCREW,HEX CAP.38-16X2.25,G8,ZC
9	1	296872-05	SHACKLE WLDMT,LB,LH,5.25
		296872-03	SHACKLE WLDMT,LB/HB,LH,5.00
		296872-01	SHACKLE WLDMT,HB,LH,4.63
10	1	296872-06	SHACKLE WLDMT,LB,RH,5.25
		296872-04	SHACKLE WLDMT,LB/HB,RH,5.00
		296872-02	SHACKLE WLDMT,HB,RH,4.63
11	2	900014-18	SCREW,HEX CAP.38-16X2.75,G8,ZC
12	1	286038-02	TORSION SPRING,LH HELIX

TE-25/30 MAIN ASSEMBLY PAINTED WITH DUAL TORSION SPRINGS, PINS AND BUSHINGS

LAST UPDATED
MAY 2017 to DEC 2020

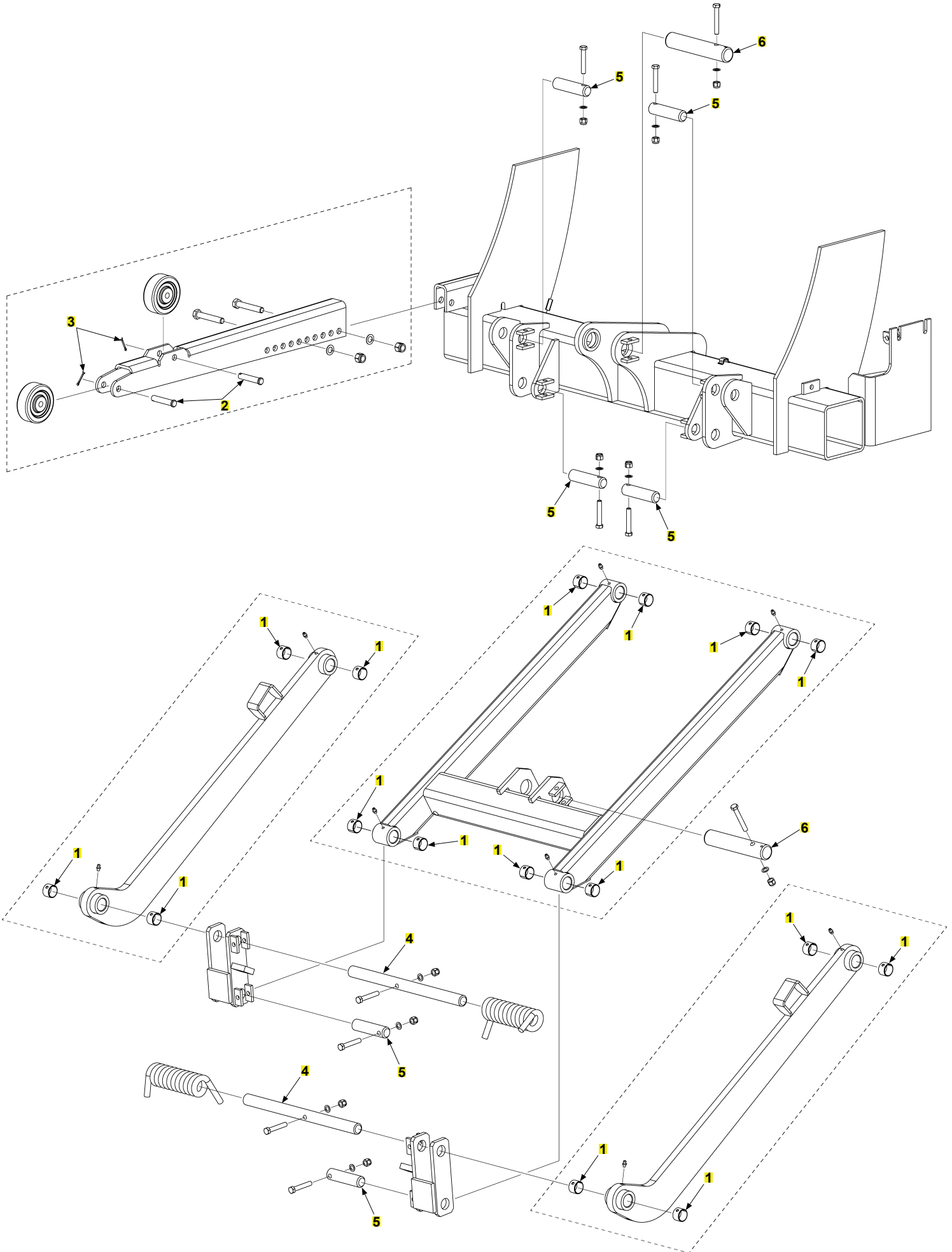

TE-25/30 MAIN ASSEMBLY PAINTED WITH DUAL TORSION SPRINGS, PINS AND BUSHINGS**LAST UPDATED
MAY 2017 to DEC 2020**

ITEM	QTY.	PART NO.	DESCRIPTION
1	16	260916-08	BEARING,SELF LUBE 1"DIA X .75"
2	2	905202-03	PIN CLEVIS, .500 DIA X 2.50
3	2	030805	COTTER PIN 1/8 X 1"
4	2	262981	PIN 1"DIA X 14.00"LG
5	6	252686	PIN 1"DIA. 4.00"LG
6	2	286074-01	PIN, CYLINDER

TE-25/30 MAIN ASSEMBLY GALVANIZED WITH DUAL TORSION SPRINGS

LAST UPDATED
MAY 2017 to DEC 2020

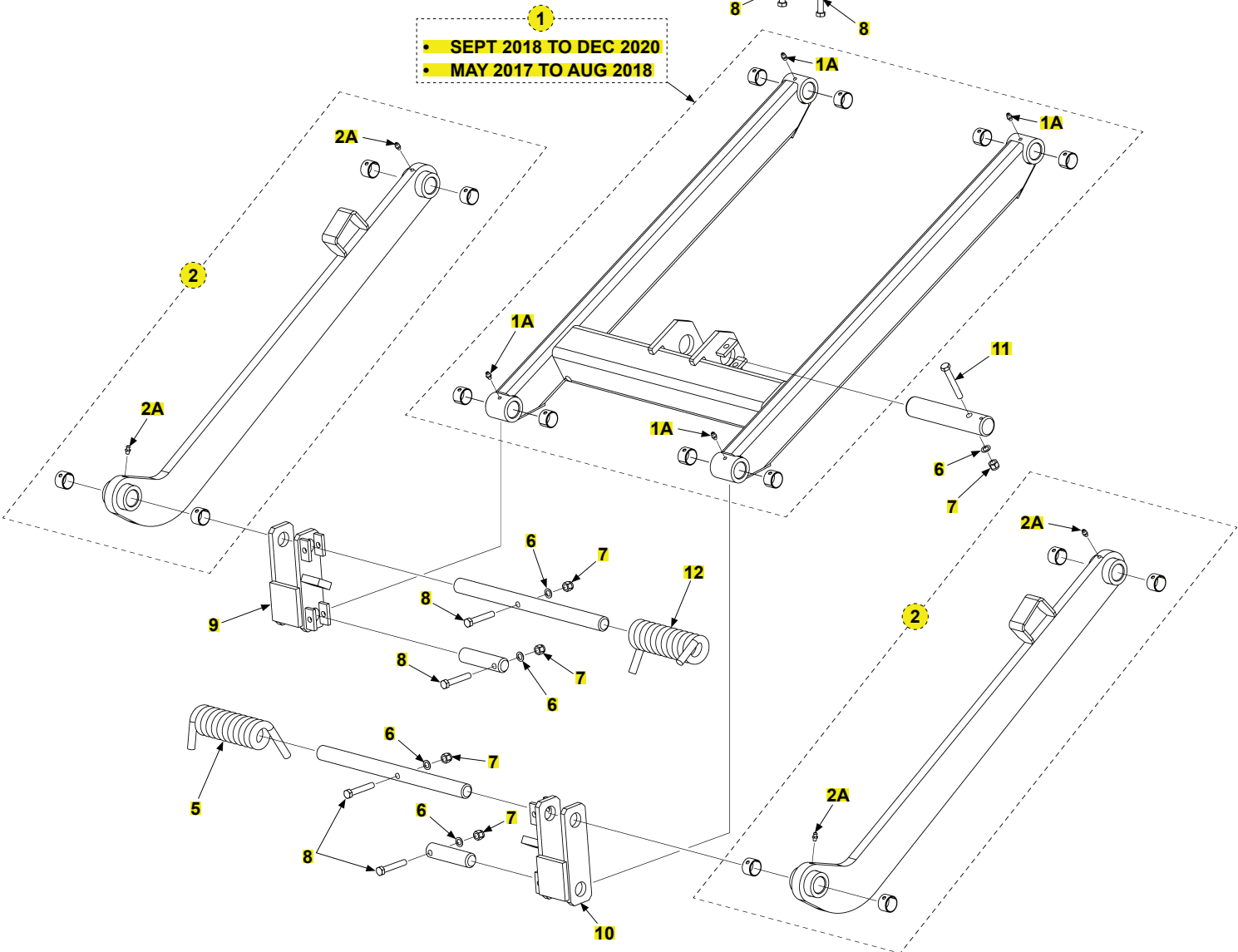
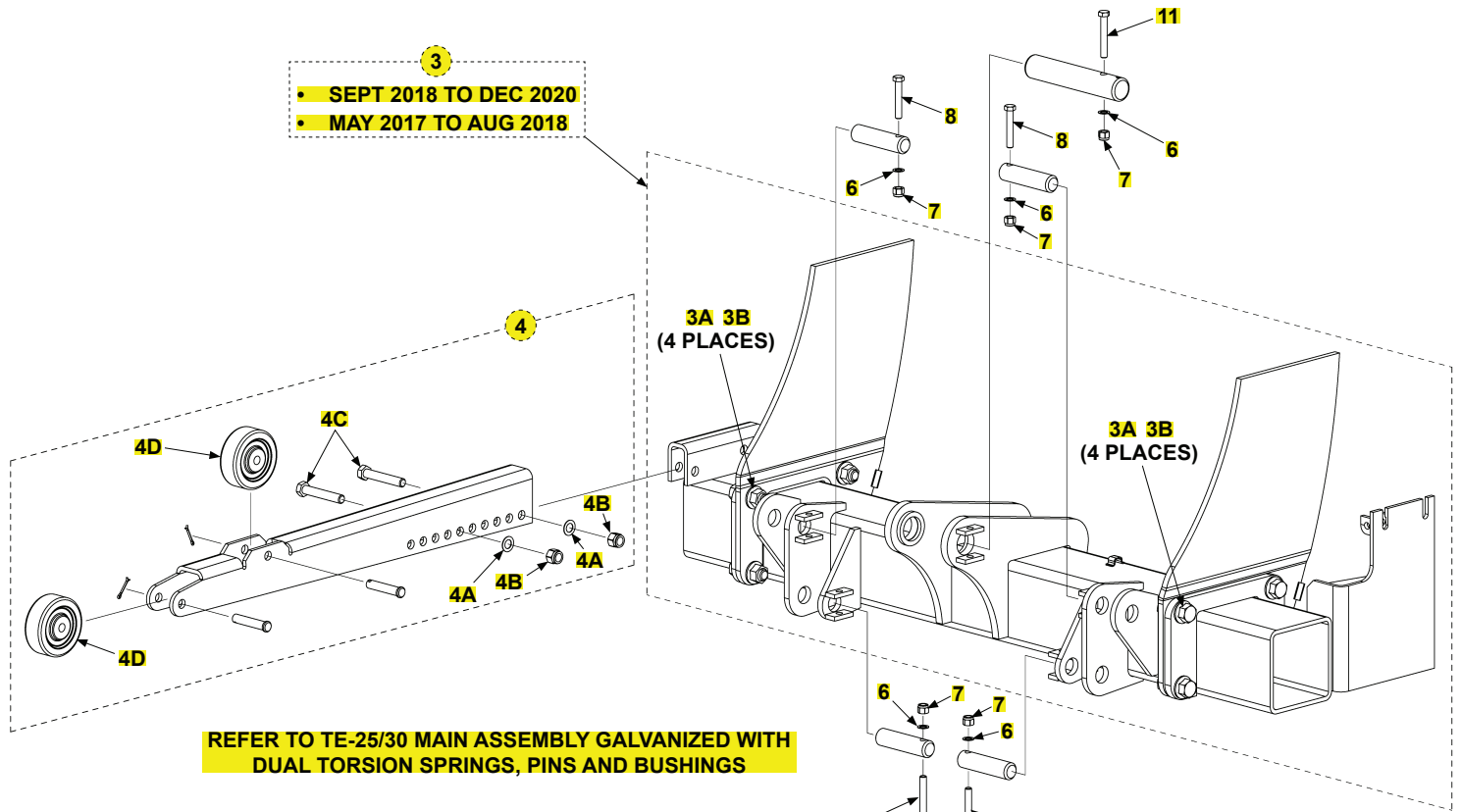

TE-25/30 MAIN ASSEMBLY GALVANIZED WITH DUAL TORSION SPRINGS

LAST UPDATED
MAY 2017 to DEC 2020

ITEM	QTY.	PART NO.	DESCRIPTION
1	1	298073-01G	LIFT FRAME ASSY, GA (SEPT 2018 TO DEC 2020)
		286009-01G	LIFT FRAME ASSY, GAL (MAY 2017 TO AUG 2018)
1A	4	224342	FITTING, GREASE 1/4"SELF DRILL
2	2	286007-01G	PARALLEL ARM ASSY,GAL
2A	4	224342	FITTING, GREASE 1/4"SELF DRILL
3	1	298084-01G	M/F ASSY,BOLTED,34.25 & 33.75 MNT,G (SEPT 2018 TO DEC 2020)
		296868-01G	M/F ASSY, BOLTED, 34.25 & 33.75 MNT, G (MAY 2017 TO AUG 2018)
3A	2	901023-04	FLANGE LOCK NUT,63-11,ZC
3B	2	901615-03	BOLT HEX FRAME .63-11X1.75"LG
4	1	287060-01G	KIT, OPENER, TUK-A-WAY,G
4A	2	902000-13	WASHER, FLAT .500 .032 THK
4B	2	901010	NUT, NYLON LOCK 1/2-13 ZC
4C	2	900035-9	SCREW,CAP HXHD.5-13UNC-2A 3.00
4D	2	280082-01	ROLLER, OPENER,3.5 X 1.25 X .5
5	1	286038-01	TORSION SPRING, RH HELIX
6	10	902000-9	WASHER, FLAT.375X.032 THK
7	10	901002	NUT, NYLON 3/8-16 ZINC
8	8	900014-9	SCREW,HEX CAP.38-16X2.25,G8,ZC
9	1	296872-05G	SHACKLE WLDMT,LB,LH,5.25,G
		296872-03G	SHACKLE WLDMT,LB/HB,LH,5.00,CAL
		296872-01G	SHACKLE WLDMT,HB,LH,4.63,GAL
10	1	296872-06G	SHACKLE WLDMT,LB,RH,5.25,G
		296872-04G	SHACKLE WLDMT,LB/HB,RH,5.00,GAL
		296872-02G	SHACKLE WLDMT,HB,RH,4.63,GAL
11	2	900014-18	SCREW,HEX CAP.38-16X2.75,G8,ZC
12	1	286038-02	TORSION SPRING,LH HELIX

TE-25/30 MAIN ASSEMBLY GALVANIZED WITH DUAL TORSION SPRINGS, PINS AND BUSHINGS

LAST UPDATED
MAY 2017 to DEC 2020

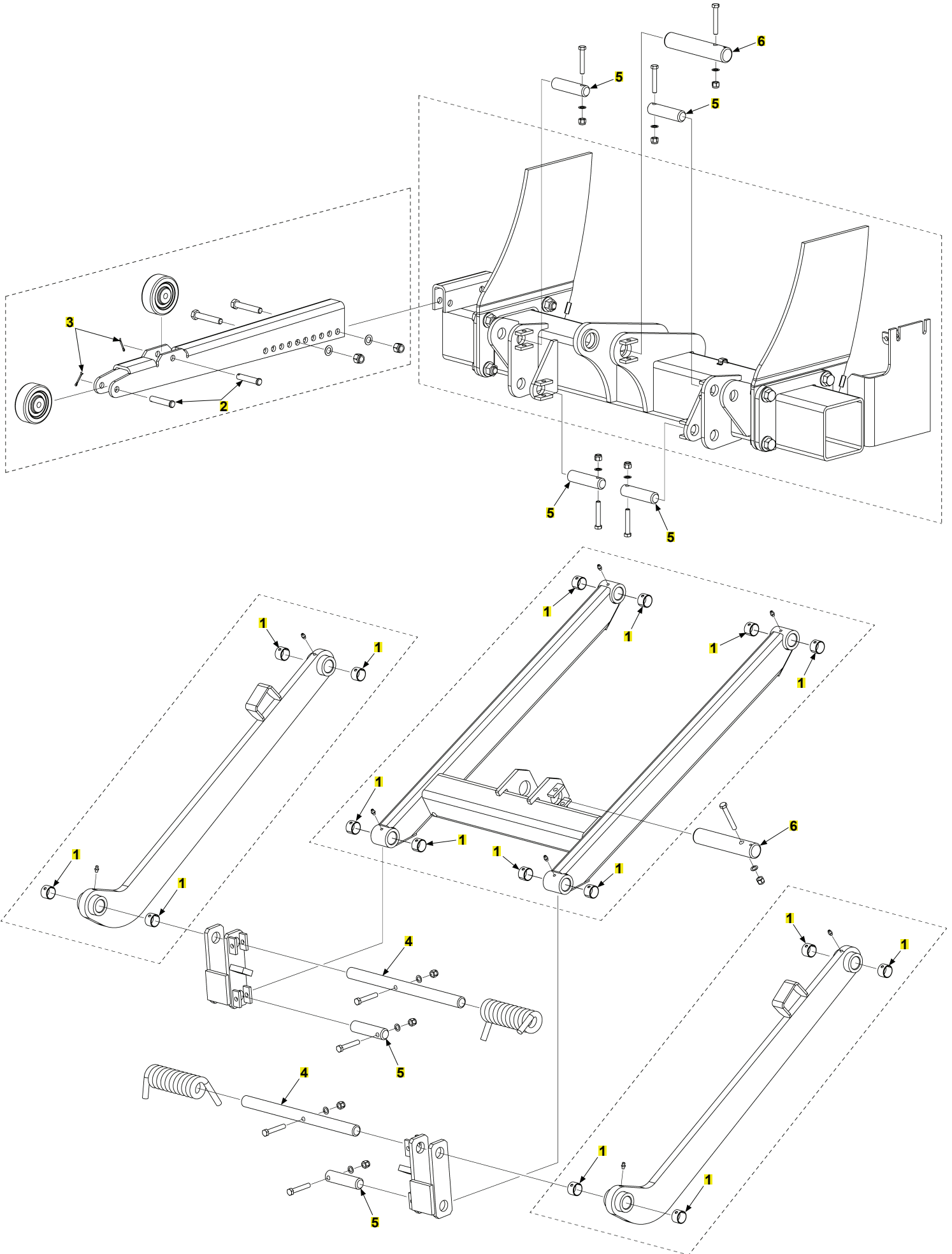

TE-25/30 MAIN ASSEMBLY GALVANIZED WITH DUAL TORSION SPRINGS, PINS AND BUSHINGS**LAST UPDATED
MAY 2017 to DEC 2020**

ITEM	QTY.	PART NO.	DESCRIPTION
1	16	260916-08	BEARING,SELF LUBE 1"DIA X .75"
2	2	905202-03	PIN CLEVIS, .500 DIA X 2.50
3	2	030805	COTTER PIN 1/8 X 1"
4	2	262981	PIN 1"DIA X 14.00"LG
5	6	252686	PIN 1"DIA. 4.00"LG
6	2	286074-01	PIN, CYLINDER

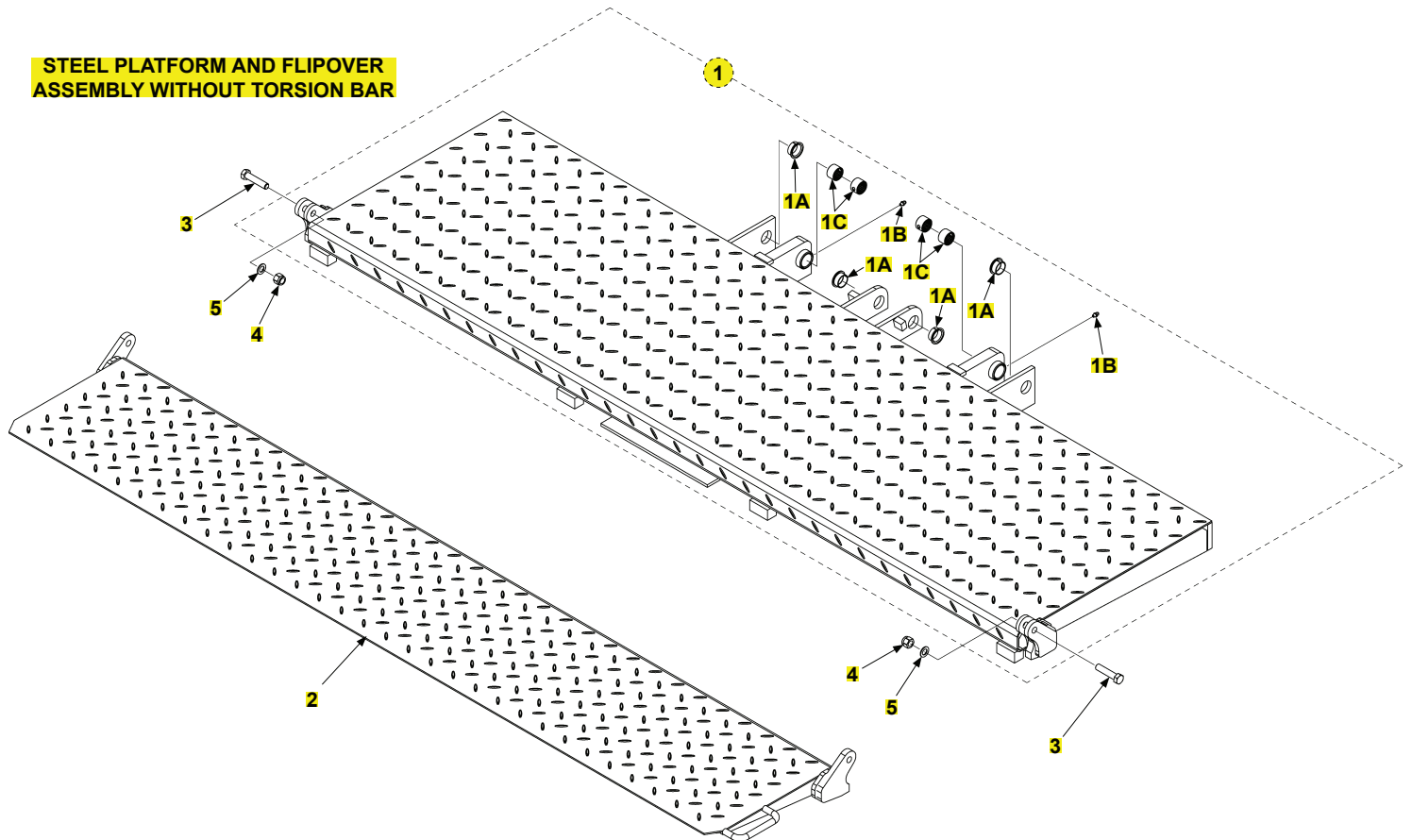

ITEM	QTY.	PART NO.	DESCRIPTION
REF	1	296650-01	P/F & F/O ASSY,80X22+14 ST
		296650-01G	P/F & F/O ASSY,80X22+14 ST, GALV.
1	1	298578-01	P/F ASSY, STL 80X22
		298578-01G	P/F ASSY, STL 80X22,G
1A	4	908002-03	BEARING,SELF LUB.1ID X.5 LG
1B	2	224342	FITTING, GREASE 1/4"SELF DRILL
1C	4	908178-01	BEARING,PRE LUBRICATING 1.00ID X .75 LG
2	1	296870-01	F/O WLDMT,ST 80 X 14,WDG
		296870-01G	F/O WLDMT,ST 80 X 14,WDG,G
3	2	900033-6	SCREW, CAP.5-20X2.25 GR8 ZC
4	2	901008	NUT, NYLON 1/2-20 ZC
5	2	902000-14	WASHER, FLAT .500X.063 THK

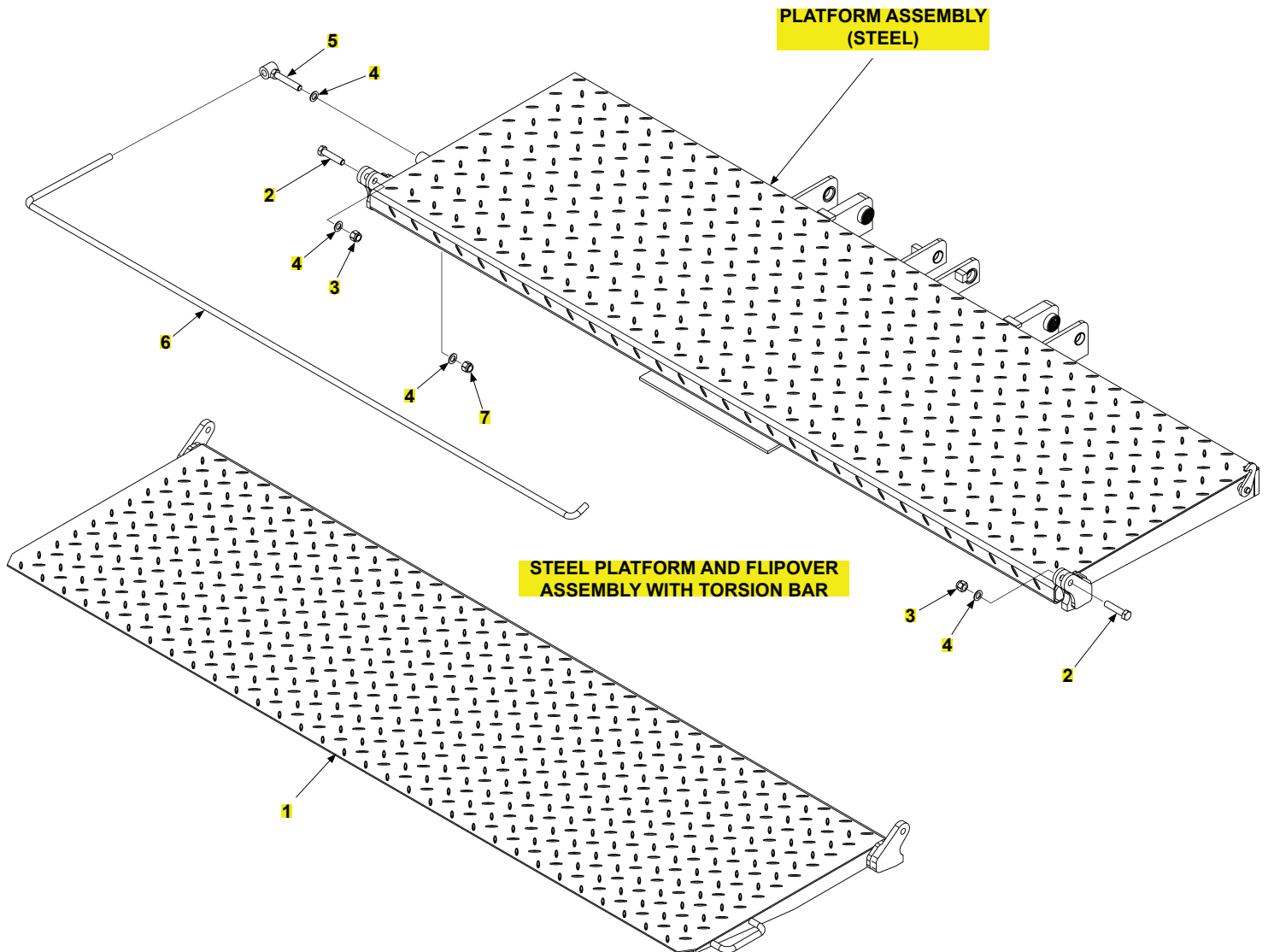

ITEM	QTY.	PART NO.	DESCRIPTION
REF	1	296650-02	P/F & F/O ASSY,80X24+24 ST
		296650-02G	P/F & F/O ASSY,80X24+24 ST, GALV.
1	1	296870-02	F/O WLDMT,ST 80X24,WDG,TB
		296870-02G	F/O WLDMT,ST 80X24,WDG,TB,G
2	2	900033-6	SCREW, CAP.5-20X2.25 GR8 ZC
3	2	901008	NUT, NYLON 1/2-20 ZC
4	4	902000-14	WASHER, FLAT .500X.063 THK
5	1	280749-02	ANCHOR BOLT WLDMT, ZINC PLATE
6	1	280751-01	TORSION BAR
7	1	901010	NUT, NYLON LOCK 1/2-13 ZC

**STEEL PLATFORM AND ALUMINUM
FLIPOVER ASSEMBLY**

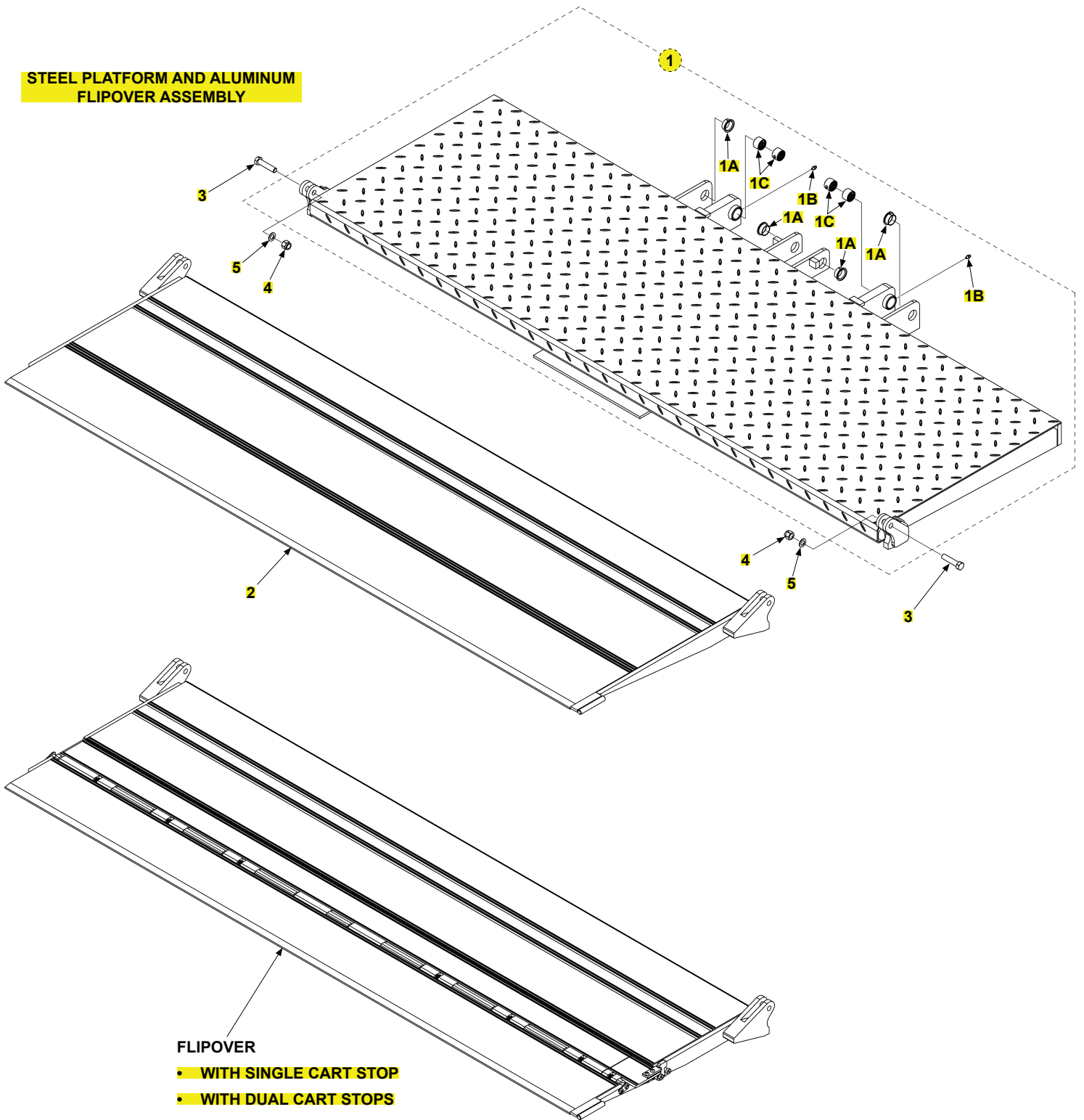

TE-25/30 STEEL PLATFORM AND ALUMINUM FLIPOVER ASSEMBLY

LAST UPDATED
MAY 2017 to DEC 2020

ITEM	QTY.	PART NO.	DESCRIPTION
REF	1	296650-04	P/F & F/O ASSY,80X24+24,ST-AL NCS
		296650-04G	P/F & F/O ASSY,80X24+24,ST-AL NCS, GALV.
		296650-05	P/F & F/O ASSY,80X26+26,ST-AL NCS
		296650-05G	P/F & F/O ASSY,80X26+26,ST-AL NCS, GALV.
		296650-06	P/F & F/O ASSY,80X24+24,ST-AL SCS
		296650-06G	P/F & F/O ASSY,80X24+24,ST-AL SCS, GALV.
		296650-07	P/F & F/O ASSY,80X26+26,ST-AL SCS
		296650-07G	P/F & F/O ASSY,80X26+26,ST-AL SCS, GALV.
		296650-08	P/F & F/O ASSY,80X24+24,ST-AL DCS
		296650-08G	P/F & F/O ASSY,80X24+24,ST-AL DCS, GALV.
		296650-09	P/F & F/O ASSY,80X26+26,ST-AL DCS
		296650-09G	P/F & F/O ASSY,80X26+26,ST-AL DCS, GALV.
1	1	298578-04	P/F ASSY,STL 80X24,W/OUT LATCH
		298578-04G	P/F ASSY,STL 80X24,W/OUT LATCH,G
		298578-02	P/F ASSY,STL 80X26
		298578-02G	P/F ASSY,STL 80X26,G
1A	4	908002-03	BEARING,SELF LUB.1ID X.5 LG
1B	2	224342	FITTING, GREASE 1/4"SELF DRILL
1C	4	908178-01	BEARING,PRE LUBRICATING 1.00ID X .75 LG
2	1	296879-01	F/O WLDMT, AL 80X24, NCS
		296879-02	F/O WLDMT,AL 80X26,NCS
3	2	900033-8	SCREW, CAP.5-20X2.75 GR8 ZC
4	2	901008	NUT, NYLON 1/2-20 ZC
5	2	902000-14	WASHER, FLAT .500X.063 THK

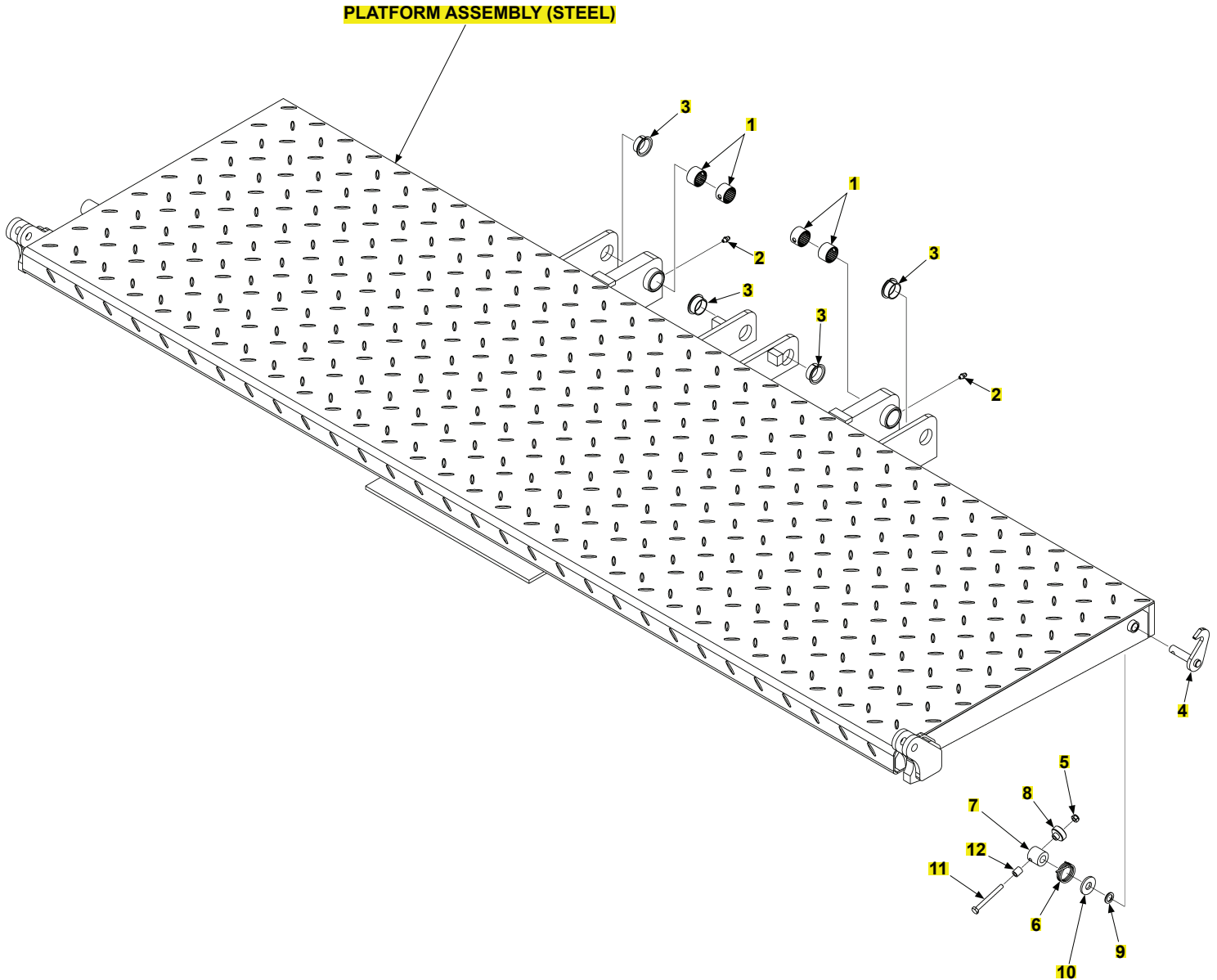

ITEM	QTY.	PART NO.	DESCRIPTION
REF	1	296878-03	P/F ASSY,STL 80X24,W/LATCH
		296878-03G	P/F ASSY,STL 80X24,W/LATCH,G
1	4	908178-01	BEARING,P/RE LUBRICATING 1.00ID X .75 LG
2	2	224342	FITTING, GREASE 1/4"SELF DRILL
3	4	908002-03	BEARING,SELF LUB.1ID X.5 LG
4	1	284828-01	HOOK W/LDMT, P/F & F/O
5	1	901016-2	NUT HEX THN HD LKG.250-20UNC
6	1	284849-01	TORSION SPRING, SS TE-25
7	1	284833-01	BUSHING, NYL 1.0X.52 IDX.91
8	1	284832-01	SPACER, NYLON, 1" OD
9	1	903413-02	WASHER,6/6 NYLON.5IDX.062TH
10	1	284852-01	WASHER,ZC 1.25X.52X.125 THK
11	1	900004-10	SCREW, CAP 1/4-20X2-1/2 GR8 ZC
12	1	284851-01	SPACER, NYLON .44X.63LGX.266

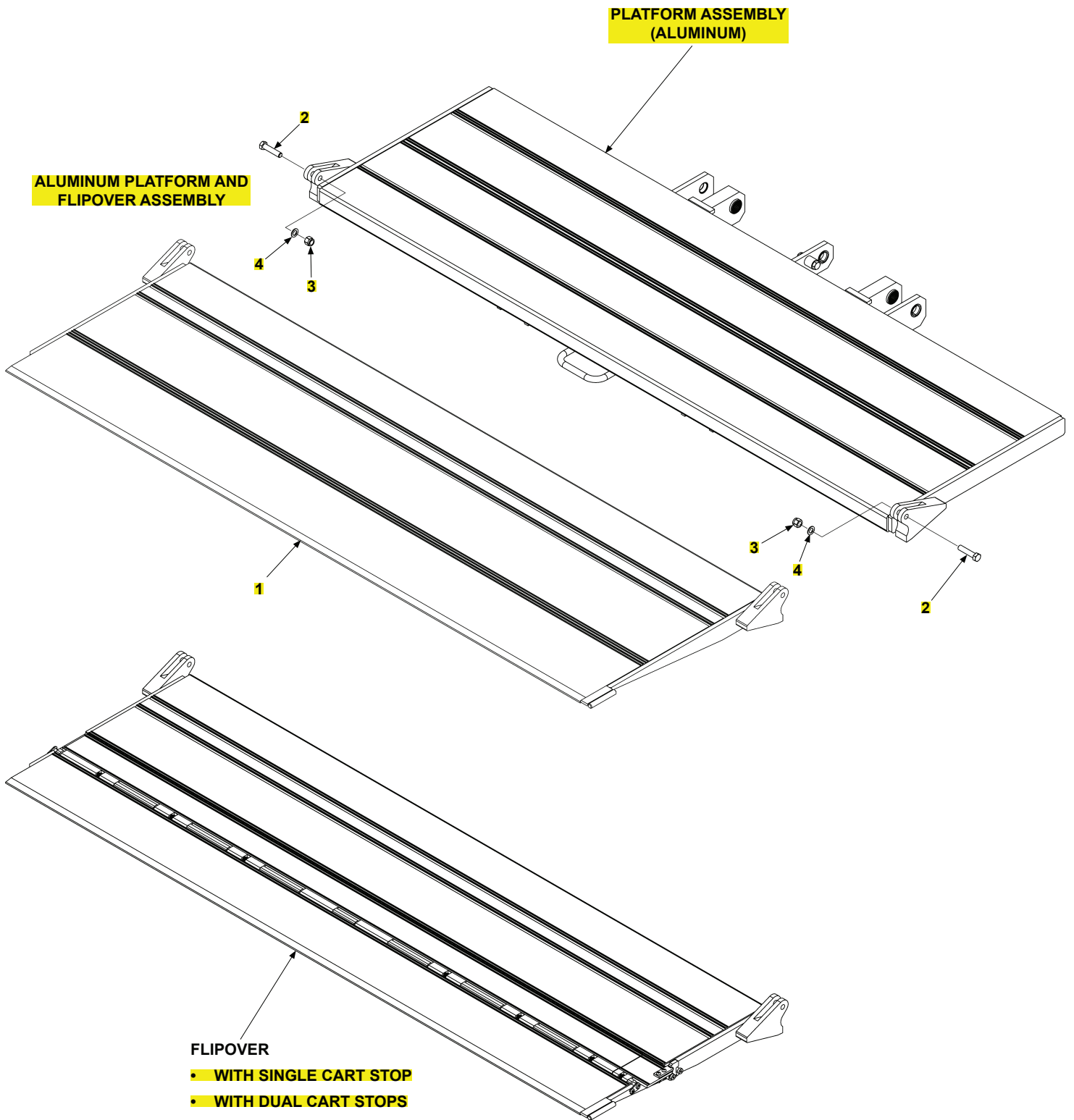

TE-25/30 ALUMINUM PLATFORM AND FLIPOVER ASSEMBLY

LAST UPDATED
MAY 2017 to DEC 2020

ITEM	QTY.	PART NO.	DESCRIPTION
REF	1	296650-10	P/F & F/O ASSY,80X24+24,AL-AL,NCS
		296650-11	P/F & F/O ASSY,80X26+26,AL-AL,NCS
		296650-12	P/F & F/O ASSY,80X24+24,AL-AL,SCS
		296650-13	P/F & F/O ASSY,80X26+26,AL-AL,SCS
		296650-14	P/F & F/O ASSY,80X24+24,AL-AL,DCS
		296650-15	P/F & F/O ASSY,80X26+26,AL-AL,DCS
1	1	296879-01	F/O WLDMT, AL 80X24, NCS
		296879-02	F/O WLDMT,AL 80X26,NCS
2	2	900033-8	SCREW, CAP.5-20X2.75 GR8 ZC
3	2	901008	NUT, NYLON 1/2-20 ZC
4	2	902000-14	WASHER, FLAT .500X.063 THK

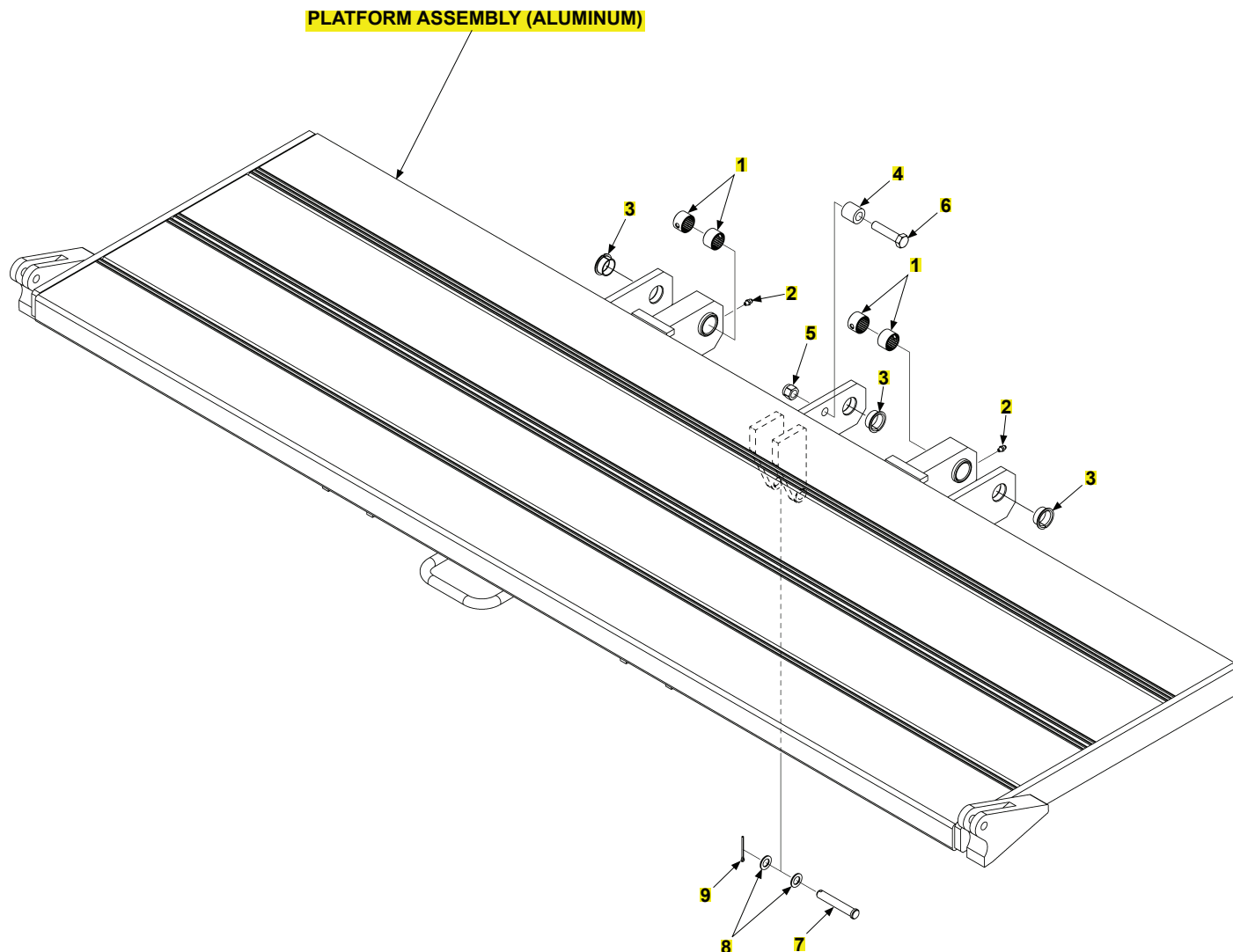

ITEM	QTY.	PART NO.	DESCRIPTION
REF	1	296893-01	P/F ASSY, AL 80 X 24
		296893-02	P/F ASSY, AL 80 X 26
		296893-03	P/F ASSY, AL 80 X 22
1	4	908178-01	BEARING,PRE LUBRICATING 1.00ID X .75 LG
2	2	224342	FITTING, GREASE 1/4"SELF DRILL
3	3	908002-03	BEARING,SELF LUB.1ID X.5 LG
4	1	286053-01	BUSHING, PLATFORM SPRING
5	1	901010	NUT, NYLON LOCK 1/2-13 ZC
6	1	900035-6	SCREW,CAP HXHD.5-13UNC-2A 2.25
7	1	261838	PIN, CLEVIS 1/2 X 3 ZINC
8	2	902000-14	WASHER, FLAT .500X.063 THK
9	1	030177	PIN COTTER 1/8X1-1/2 ZC

TE-25/30 FLIPOVER WITH SINGLE CART STOP

LAST UPDATED
MAY 2017 to DEC 2020

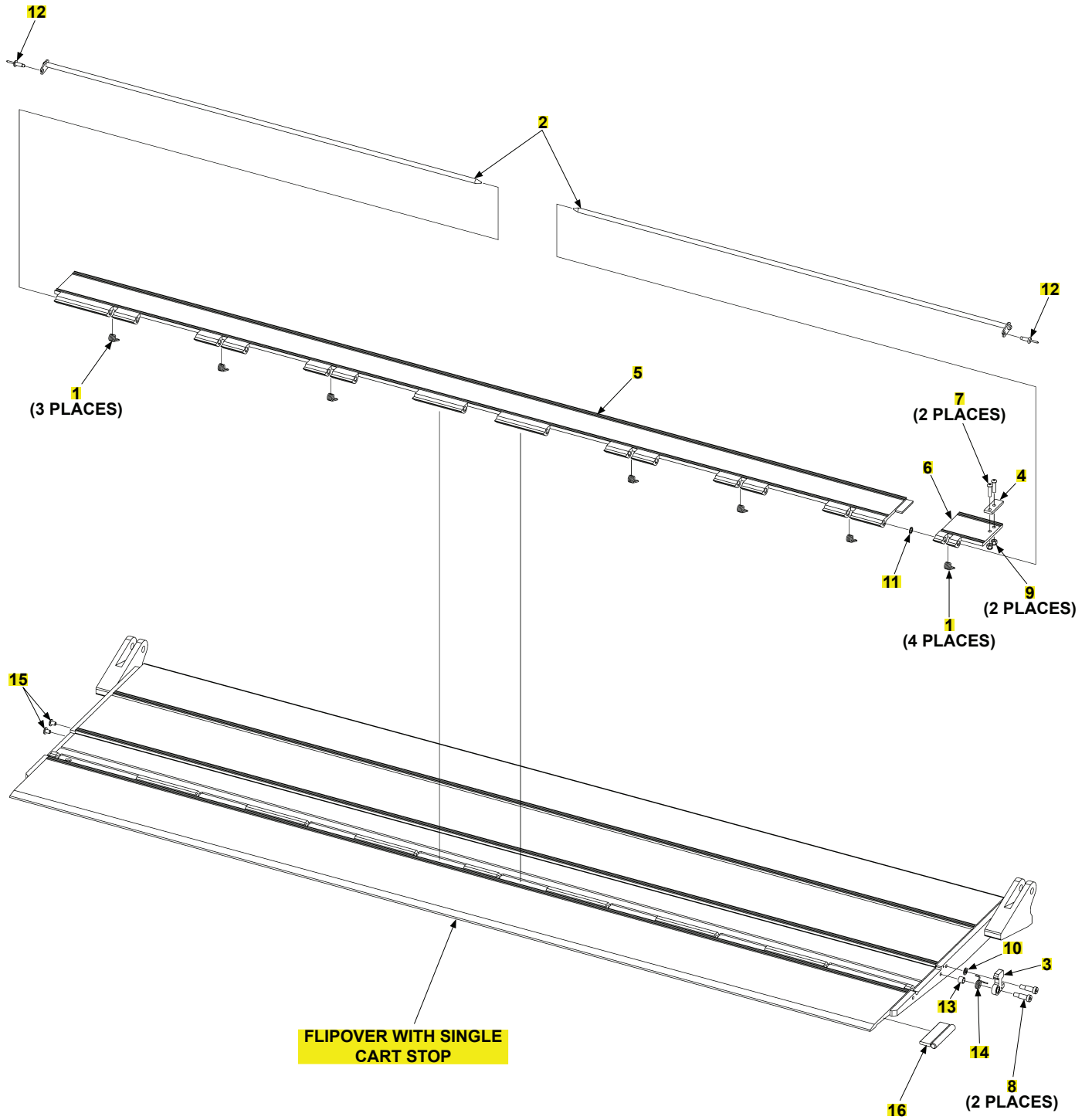

TE-25/30 FLIPOVER WITH SINGLE CART STOP

LAST UPDATED
MAY 2017 to DEC 2020

ITEM	QTY.	PART NO.	DESCRIPTION
REF	1	296895-01	F/O ASSY,AL,EXTRN HNG,SCS,80X24
		296895-02	F/O ASSY,AL,EXTRN HNG,SCS,80X26
1	7	282729-01	SPRING, C/S .08 WIRE, 302 SS
2	2	282738-03	PIN WLDMT, CART STOP
3	1	282739-01	HOOK, CART STOP LOCKING
4	1	282748-01	FLAT, C/S LOCK SUPPORT
5	1	286055-01	SINGLE CART STOP, 80" F/O
6	1	286099-02	LOCK-HINGE, CART STOP, RH
7	2	900005-4	SCREW, BUTTON 1/4-20X1 ALLOY
8	2	900723-05	SCREW,SHLDR.38 X.75 LG,SS
9	2	901000	NUT, NYLON 1/4-20 ZINC
10	1	902000-8	WASHER, FLAT .312 .063 THK
11	1	903402-08	WASHER,FLAT,NYLON,.38ID X.56OD
12	2	903715-06	RIVET,BL/DM,AL/AL .25X.62-.75
13	1	905328-01	BEARING, NYL .38IDX.50DX.38LG
14	1	282749-02	SPRING,RH HOOK,.078 WIRE,302SS
15	2	908022-07	PLUG, FLEXIBLE .275X.511
16	1	265819-01	HANDLE WELDMENT, AL, F/O

TE-25/30 FLIPOVER WITH DUAL CART STOPS

LAST UPDATED
MAY 2017 to DEC 2020

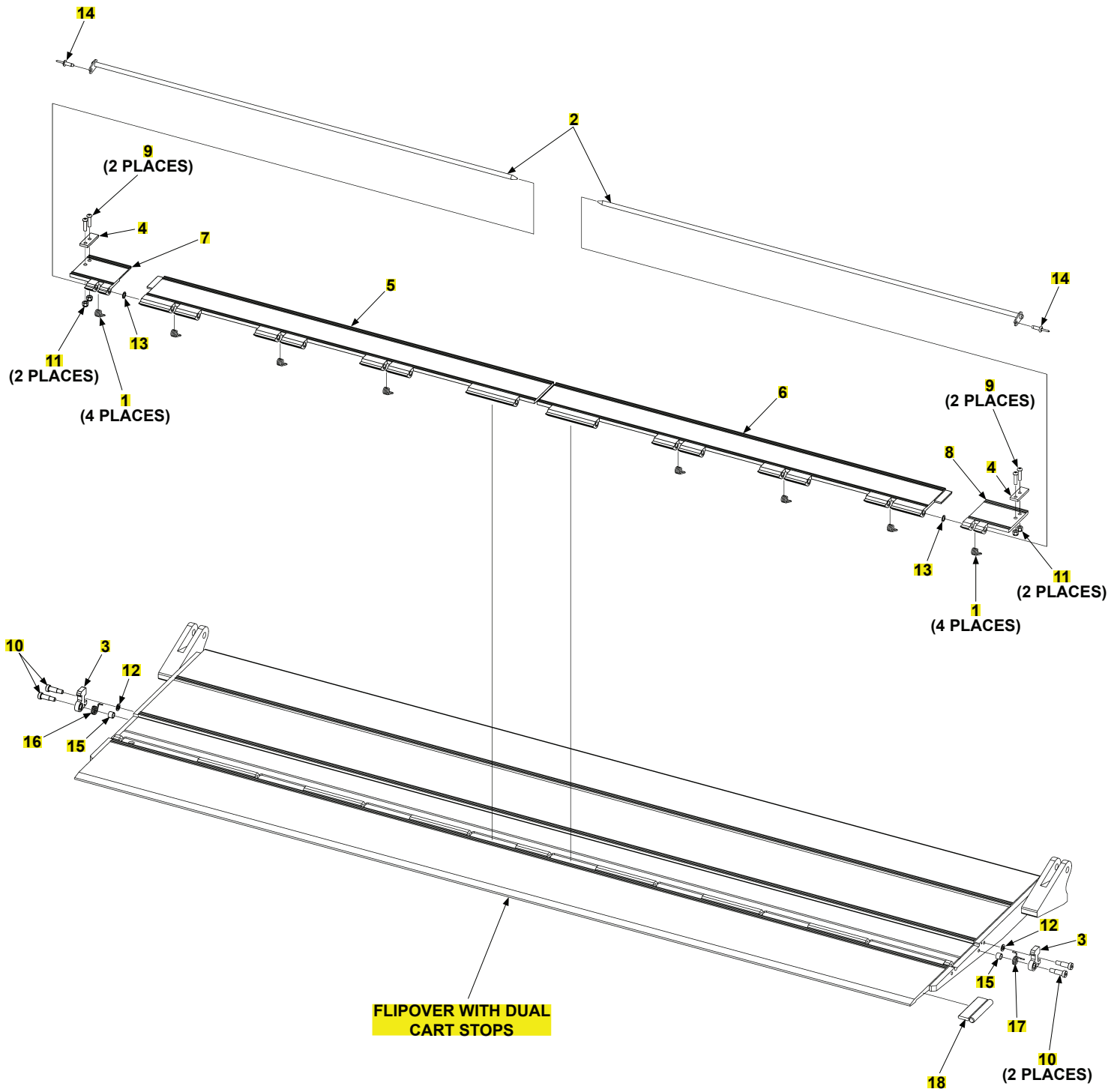

TE-25/30 FLIPOVER WITH DUAL CART STOPS

LAST UPDATED
MAY 2017 to DEC 2020

ITEM	QTY.	PART NO.	DESCRIPTION
REF	1	296895-03	F/O ASSY,AL,EXTRN HNG,DCS,80X24
		296895-04	F/O ASSY,AL,EXTRN HNG,DCS,80X26
1	8	282729-01	SPRING, C/S .08 WIRE, 302 SS
2	2	282738-03	PIN WLDMT, CART STOP
3	2	282739-01	HOOK, CART STOP LOCKING
4	2	282748-01	FLAT, C/S LOCK SUPPORT
5	1	286055-02	DUAL CART STOP, LH, 80" F/O
6	1	286055-03	DUAL CART STOP, RH, 80" F/O
7	1	286099-01	LOCK-HINGE, CART STOP, LH
8	1	286099-02	LOCK-HINGE, CART STOP, RH
9	4	900005-4	SCREW, BUTTON 1/4-20X1 ALLOY
10	4	900723-05	SCREW,SHLDR.38 X.75 LG,SS
11	4	901000	NUT, NYLON 1/4-20 ZINC
12	2	902000-8	WASHER, FLAT .312 .063 THK
13	2	903402-08	WASHER,FLAT,NYLON,.38ID X.56OD
14	2	903715-06	RIVET,BL/DM,AL/AL .25X.62-.75
15	2	905328-01	BEARING, NYL .38IDX.50DX.38LG
16	1	282749-01	SPRING,LH HOOK,.078 WIRE,302SS
17	1	282749-02	SPRING,RH HOOK,.078 WIRE,302SS
18	1	265819-01	HANDLE WELDMENT, AL, F/O

NOTE: Replacement face seal fittings come with required O-rings.

PUMP ASSEMBLY (GRAVITY DOWN)

- 12V
- 24V

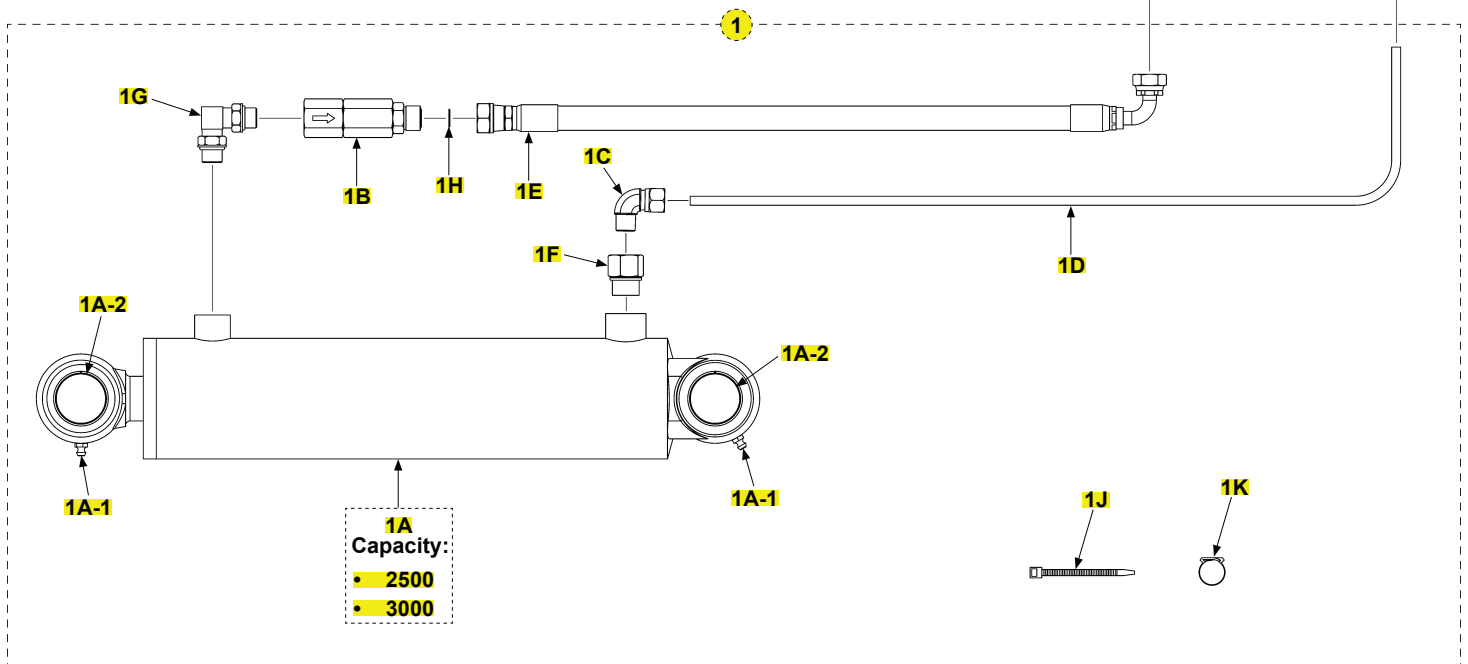
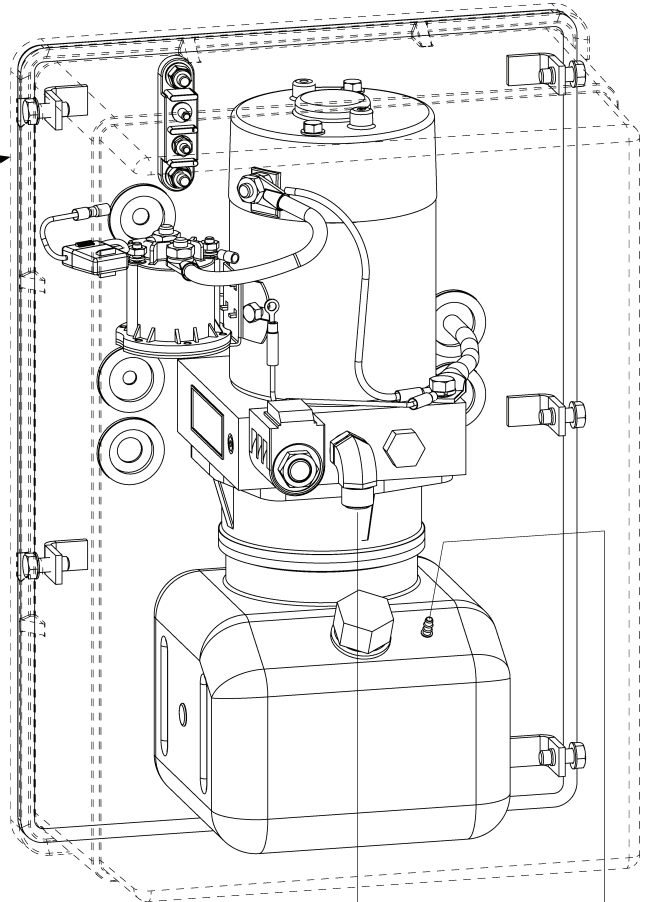

TE-25/30 HYDRAULIC SYSTEMS - GRAVITY DOWN

LAST UPDATED
MAY 2017 to DEC 2020

ITEM	QTY.	PART NO.	DESCRIPTION
1	1	287055-01	KIT,CYL,FITTING & HOSE,GD PMP,TE-25/TE-150
		287055-03	KIT,CYL,FITTING & HOSE,GD PMP,TE-30/TE-20
1A	1	297522-01	CYL DIA 3.00 BORE X 10ST. S/LB/BUSH
		297523-01	CYL 3.5 BRX10"ST.S/LB/BUSH
1A-1	2	224342	FITTING, GREASE 1/4" SELF DRILL
1A-2	4	905112-03	BEARING,SELF LUBE1.375 X 1.375
1B	1	298878-01	PRESSURE COMP. VALVE ASSY,2GPM,TE
1C	1	202406	ELBOW BRASS 1/4 X 1/4"
1D	1	224370-07	HOSE PLASTIC X 60.50"LG .25
1E	1	298024-01	H/A,3/8HP, SAENO.6,F,SW 90 DEGREES, UP LINE
1F	1	906925-01	PIPE ADAPTER, SAE-ORB/NPTF, 8-1/4
1G	1	906722-01	ELBOW, 90 NPSC O-RING #6M-M
1H	1	906712-02	O-RING #6, 3/8 ORFS TUBE END
1J	8	205780	TIE, PLASTIC 7" (50 LB)
1K	1	287513-01	NYLON HOSE CLAMP. 0.39 I.D. X .22 LONG

NOTE: Replacement face seal fittings come with required O-rings.

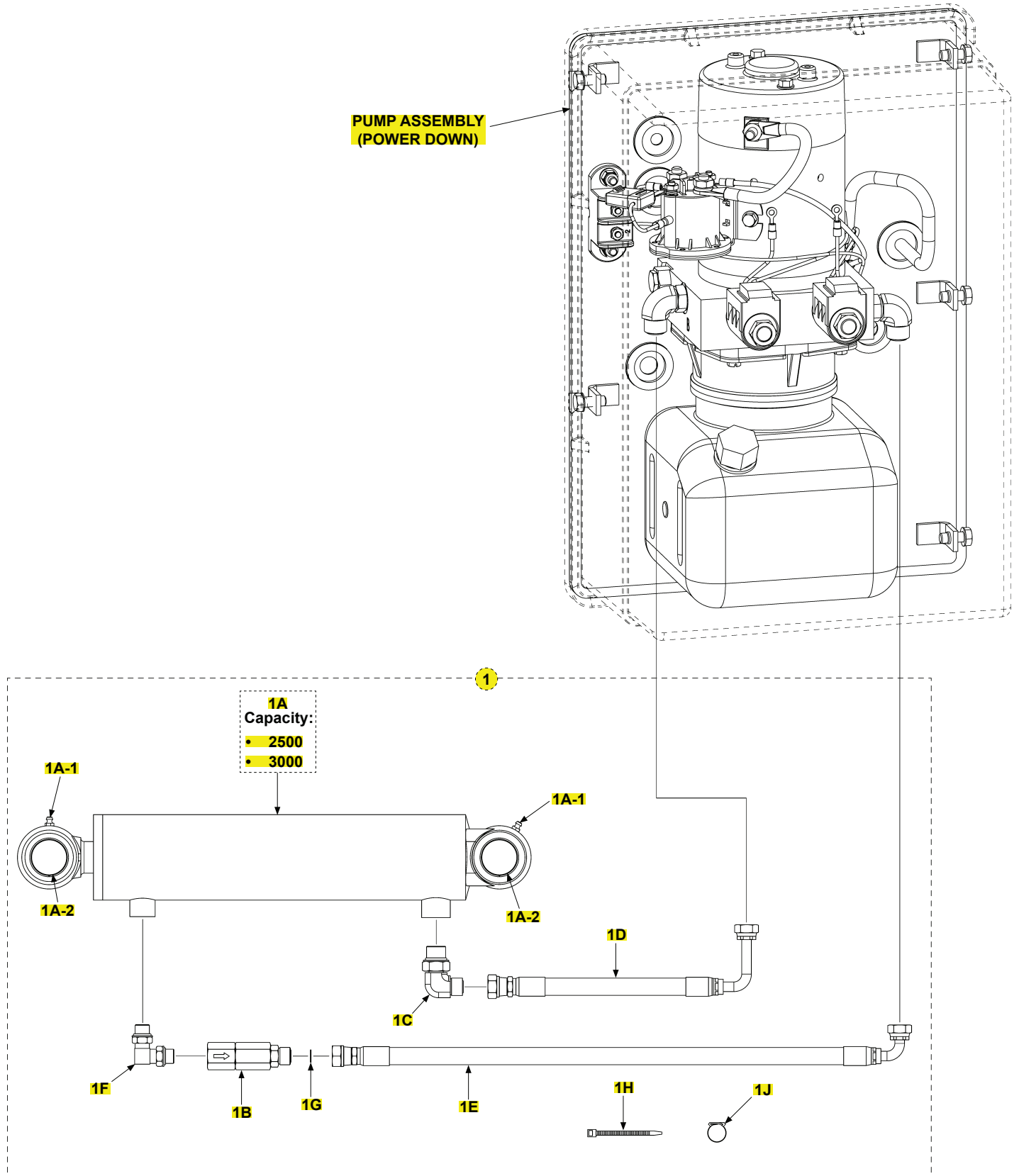

TE-25/30 HYDRAULIC SYSTEMS - POWER DOWN

LAST UPDATED
MAY 2017 to DEC 2020

ITEM	QTY.	PART NO.	DESCRIPTION
1	1	287055-02	KIT,CYL,FITTING & HOSE,PD PMP,TE-25/TE-150
		287055-04	KIT,CYL,FITTING & HOSE,PD PMP,TE-30/TE-20
1A	1	297522-01	CYL DIA 3.00 BORE X 10ST. S/LB/BUSH
		297523-01	CYL 3.5 BRX10"ST.S/LB/BUSH
1A-1	2	224342	FITTING, GREASE 1/4" SELF DRILL
1A-2	4	905112-03	BEARING,SELF LUBE1.375 X 1.375
1B	1	298878-01	PRESSURE COMP. VALVE ASSY,2GPM,TE
1C	1	906924-01	ELBOW, STR THD, #6 ORFS/#8 SAE-ORB
1D	1	298023-01	H/A,3/8HP, SAE#6,F,SW 90°, DN LINE
1E	1	298024-01	H/A,3/8HP, SAENO.6,F,SW 90 DEGREES, UP LINE
1F	1	906722-01	ELBOW, 90 NPSC O-RING #6M-M
1G	1	906712-02	O-RING #6, 3/8 ORFS TUBE END
1H	8	205780	TIE, PLASTIC 7" (50 LB)
1J	1	287513-01	NYLON HOSE CLAMP. 0.39 I.D. X .22 LONG

PUMP ASSEMBLY (GRAVITY DOWN 12V)

LAST UPDATED
MAY 2017 to DEC 2020

COMPLETE ASSEMBLY:

PUMP ASSEMBLY (GRAVITY DOWN 12V)

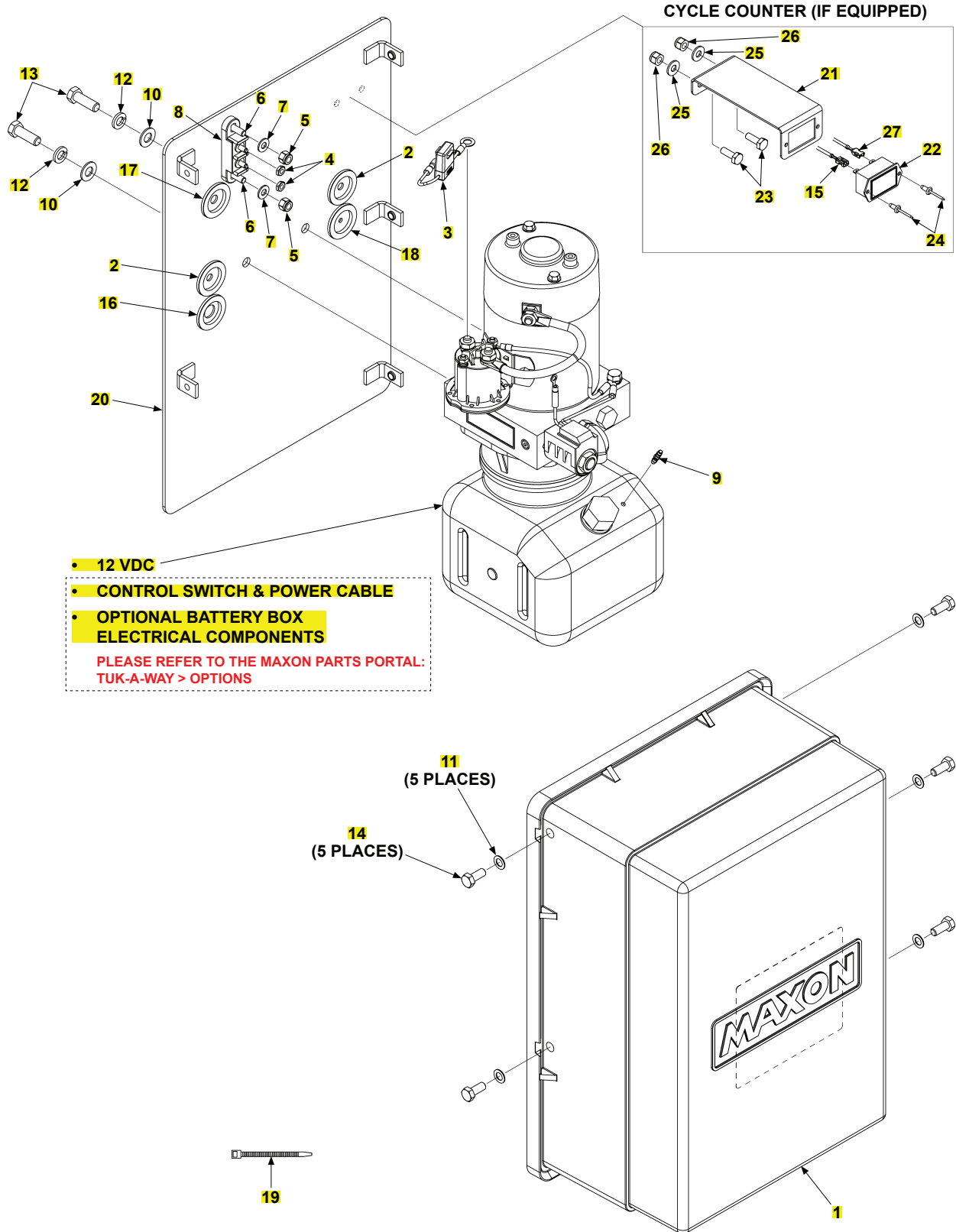

PUMP ASSEMBLY (GRAVITY DOWN 12V)

LAST UPDATED
MAY 2017 to DEC 2020

ITEM	QTY.	PART NO.	DESCRIPTION
REF	1	287070-01G	PUMP ASSY,12V,G/D,G
		287070-03G	PUMP ASSY,12V,CC,G/D,G
1	1	266419-01	COVER ASSY, TUK-A-WAY PUMP
2	2	266428-03	GROMMET, 1.0 DIA DIAPH .31 DIA HOLE
3	1	297046-01	FUSE HOLDER ASSY
4	2	903107-06	NUT, HEX 10-24 UNC SS
5	2	903137-01	NUT, NYL INSRT STOP .25-20 SS
6	2	900000-4	BOLT, HX 1/4-20X1 GR8 ZC
7	2	903412-01	WASHER,FLAT .25,SS
8	1	907279-01	JUNCTION BLOCK, TWO STUD
9	1	906728-01	FTG, TUBE, DUAL BARBED .170 ID
10	2	902013-11	WASHER, FLAT 3/8" ZC
11	5	902000-7	WASHER, FLAT .312 .032 THK
12	2	902011-4	WASHER, LOCK 3/8X.094 ZC
13	2	900014-21	SCREW, HEX CAP .38-16X1.125, G8, ZC
14	5	900009-3	BOLT,HEX 5/16-18X3/4 GR8 ZC
15	1	297274-02	WIRE ASSY, POS LOCK, RING TERM,RED
16	1	266428-06	GROMMET, 1.0 DIAPH .56 HOLE
17	1	266428-04	GROMMET, 1.0 DIAPH .38 HOLE
18	1	266428-01	GROMMET, 1.0 DIAPH .19 HOLE
19	2	205780	TIE, PLASTIC 7" (50 LB)
20	1	296921-01G	PLATE,PUMP MOUNT,WLDMT,G/D,G
		296921-02G	PLATE, PUMP MOUNT, WLDMT,CC,G
21	1	297358-01	BRACKET, DIGITAL C/COUNT
22	1	297269-01	DIGITAL CYCLE COUNTER
23	2	900004-2	SCREW, CAP 1/4-20X3/4 GR8 ZC
24	2	903721-01	RIVET, BL/DM, SS .16X.02-.13
25	2	902013-09	WASHER1/4"ZINC-SAME030564
26	2	901000	NUT, NYLON 1/4-20 ZINC
27	1	297274-01	WIRE ASSY, POS LOCK, RING TERM,BLK

PUMP ASSEMBLY (GRAVITY DOWN 24V)

LAST UPDATED
MAY 2017 to DEC 2020

COMPLETE ASSEMBLY:

PUMP ASSEMBLY (GRAVITY DOWN 24V)

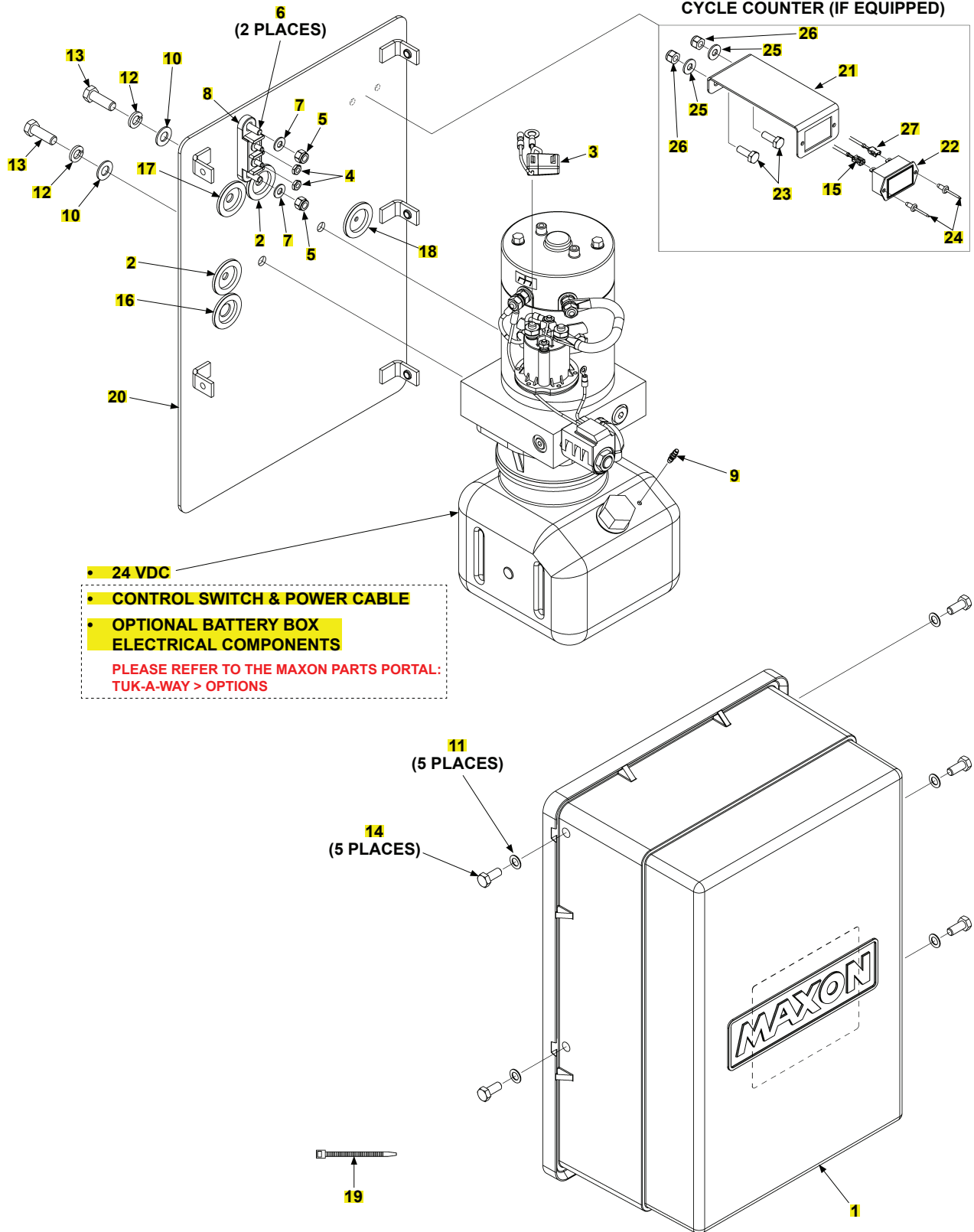

PUMP ASSEMBLY (GRAVITY DOWN 24V)

LAST UPDATED
MAY 2017 to DEC 2020

ITEM	QTY.	PART NO.	DESCRIPTION
REF	1	287070-02G	PUMP ASSY,24V.G/D,G
		287070-04G	PUMP ASSY,24V,CC,G/D,G
1	1	266419-01	COVER ASSY, TUK-A-WAY PUMP
2	2	266428-03	GROMMET, 1.0 DIA DIAPH .31 DIA HOLE
3	1	297046-01	FUSE HOLDER ASSY
4	2	903107-06	NUT, HEX 10-24 UNC SS
5	2	903137-01	NUT, NYL INSRT STOP .25-20 SS
6	2	900000-4	BOLT, HX 1/4-20X1 GR8 ZC
7	2	903412-01	WASHER,FLAT .25,SS
8	1	907279-01	JUNCTION BLOCK, TWO STUD
9	1	906728-01	FTG, TUBE, DUAL BARBED .170 ID
10	2	902013-11	WASHER, FLAT 3/8" ZC
11	5	902000-7	WASHER, FLAT .312 .032 THK
12	2	902011-4	WASHER, LOCK 3/8X.094 ZC
13	2	900014-21	SCREW, HEX CAP .38-16X1.125, G8, ZC
14	5	900009-3	BOLT,HEX 5/16-18X3/4 GR8 ZC
15	1	297274-02	WIRE ASSY, POS LOCK, RING TERM,RED
16	1	266428-06	GROMMET, 1.0 DIAPH .56 HOLE
17	1	266428-04	GROMMET, 1.0 DIAPH .38 HOLE
18	1	266428-01	GROMMET, 1.0 DIAPH .19 HOLE
19	3	205780	TIE, PLASTIC 7" (50 LB)
20	1	296921-03G	PLATE, PUMP MOUNT, WLDMT,24V,G
		296921-04G	PLATE, PUMP MOUNT, WLDMT,CC,24V,G
21	1	297358-01	BRACKET, DIGITAL C/COUNT
22	1	297269-01	DIGITAL CYCLE COUNTER
23	2	900004-2	SCREW, CAP 1/4-20X3/4 GR8 ZC
24	2	903721-01	RIVET, BL/DM, SS .16X.02-.13
25	2	902013-09	WASHER1/4"ZINC-SAME030564
26	2	901000	NUT, NYLON 1/4-20 ZINC
27	1	297274-01	WIRE ASSY, POS LOCK, RING TERM,BLK

PUMP ASSEMBLY (POWER DOWN)

LAST UPDATED
MAY 2017 to DEC 2020

COMPLETE ASSEMBLY:

PUMP ASSEMBLY (POWER DOWN)

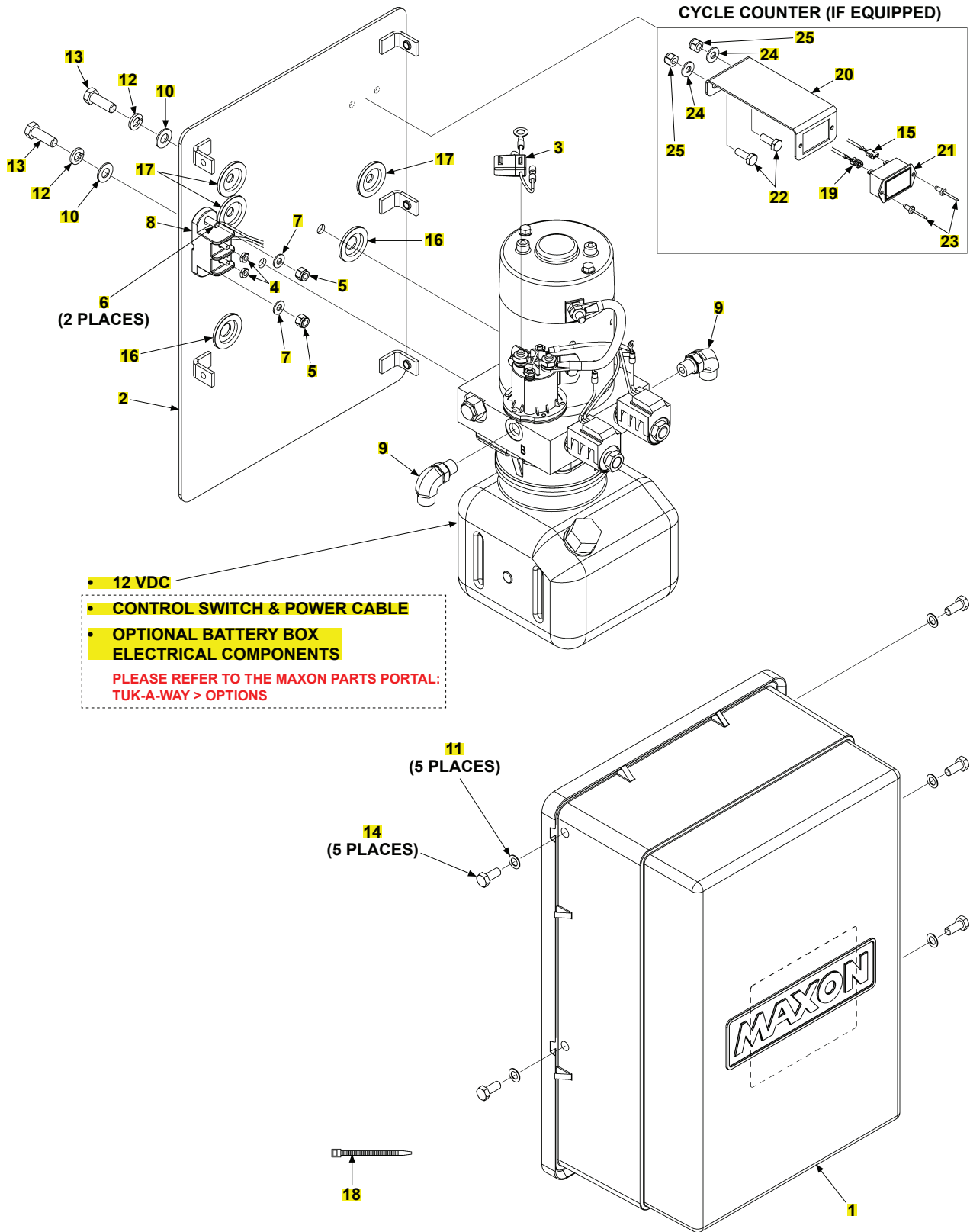

PUMP ASSEMBLY (POWER DOWN)

LAST UPDATED
MAY 2017 to DEC 2020

ITEM	QTY.	PART NO.	DESCRIPTION
REF	1	287075-01G	PUMP ASSY,12V, P/D
		287075-02G	PUMP ASSY,12V,P/D,CC,G
1	1	266419-01	COVER ASSY, TUK-A-WAY PUMP
2	1	296919-01G	PLATE WLDMT, P/D PMP MT, GALV
3	1	297046-01	FUSE HOLDER ASSY
4	2	903172-01	NUT, NYL INSRT STOP 10-32 SS
5	2	903137-01	NUT, NYL INSRT STOP .25-20 SS
6	2	900000-4	BOLT, HX 1/4-20X1 GR8 ZC
7	2	903412-01	WASHER,FLAT .25,SS
8	1	296859-01	POWER DOWN MODULE
9	2	906707-01	ELBOW, NPSC,SAE #6 F/S O-R M-M
10	2	902013-11	WASHER, FLAT 3/8" ZC
11	5	902000-7	WASHER, FLAT .312 .032 THK
12	2	902011-4	WASHER, LOCK 3/8X.094 ZC
13	2	900014-21	SCREW, HEX CAP .38-16X1.125, G8, ZC
14	5	900009-3	BOLT,HEX 5/16-18X3/4 GR8 ZC
15	1	297274-01	WIRE ASSY, POS LOCK, RING TERM,BLK
16	2	266428-06	GROMMET, 1.0 DIAPH .56 HOLE
17	3	266428-04	GROMMET, 1.0 DIAPH .38 HOLE
18	3	205780	TIE, PLASTIC 7" (50 LB)
19	1	297274-02	WIRE ASSY, POS LOCK, RING TERM,RED
20	1	297358-01	BRACKET, DIGITAL C/COUNT
21	1	297269-01	DIGITAL CYCLE COUNTER
22	2	900004-2	SCREW, CAP 1/4-20X3/4 GR8 ZC
23	2	903721-01	RIVET, BL/DM, SS .16X.02-.13
24	2	902013-09	WASHER1/4"ZINC-SAME030564
25	2	901000	NUT, NYLON 1/4-20 ZINC

CAUTION

Do not over-tighten the terminal nuts on starter solenoid. For the load terminals, torque nuts to 40 lbs.-in. max. Torque the nuts on #10-32 control terminals 15-20 lbs.-in.

CAUTION

To prevent damage when installing 2-way valves, torque valve cartridge nut to 30 lbs.-in. max.

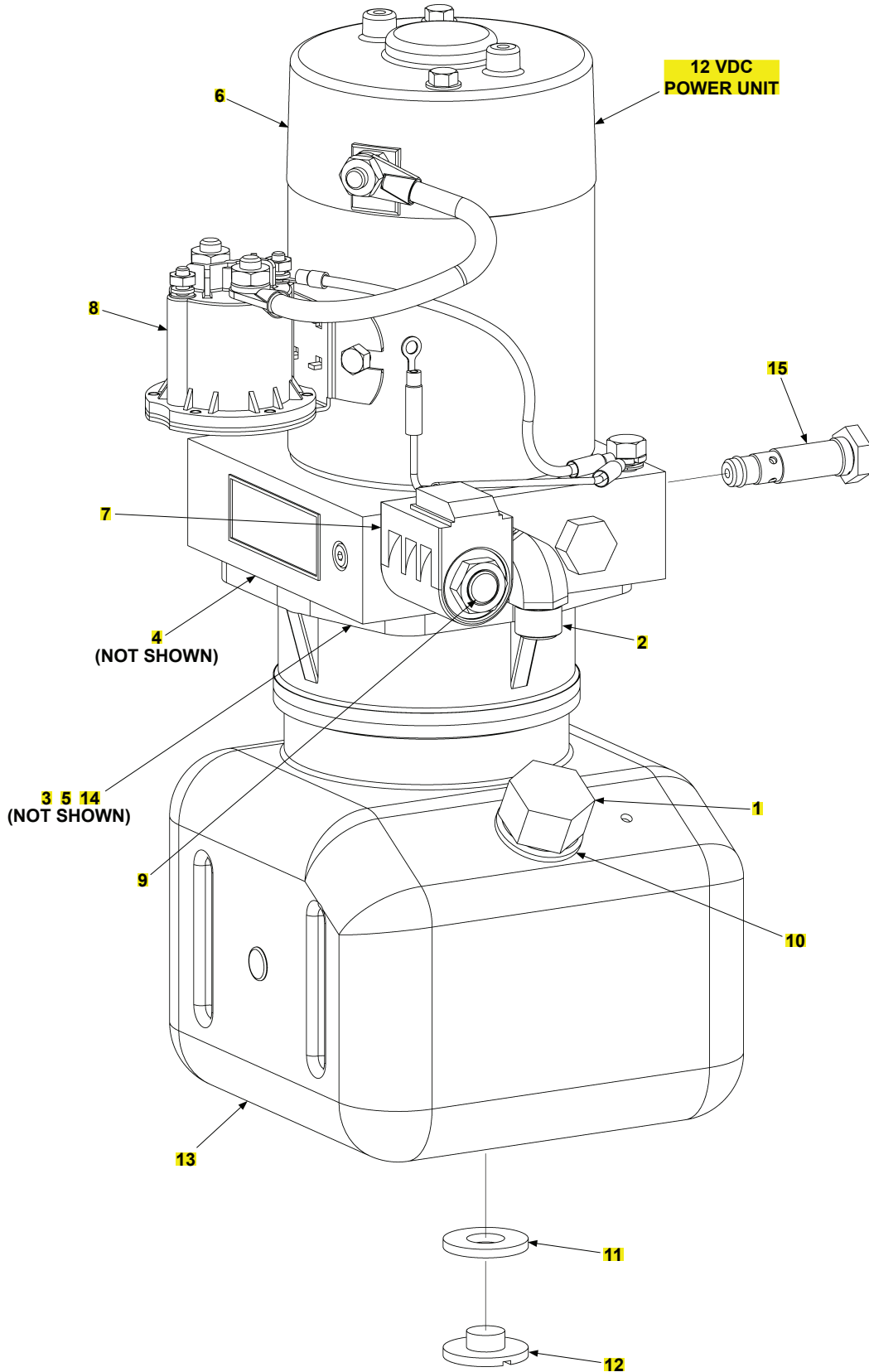

12 VDC POWER UNIT (GRAVITY DOWN)**LAST UPDATED
MAY 2017 to DEC 2020**

ITEM	QTY.	PART NO.	DESCRIPTION
REF	1	287071-01	12 VDC PWR UNIT, G/D, TUK-A-WAY
1	1	280806-01	FILLER, BREATHER
2	1	906707-01	ELBOW, NPSC,SAE #6 F/S O-R M-M
3	1	260261	OIL SEAL,PUMP
4	1	290061	SEAL SQUARE CUT PL RESERVOIR
5	1	290020	O-RING, KEPNER CHECK VALVE
6	1	290175-01	12VDC MOTOR W/OUT TERM SW
7	1	290210	12 VDC COIL, DOUBLE LEADS (PDL12) (39002186)
8	1	284080-01	SWITCH, SOLENOID ASSY
9	1	290215	VALVE 2P2W NC DELTA (38502314)
10	1	908016-01	GROMMET, RUBBER, .60 ID
11	1	290209	WASHER, .56 ID X 1.25 OD (61200504)
12	1	290208	PLUG, 9/16-18, PLASTIC TANK (35901162)
13	1	290207	RESERVOIR, PLASTIC, 8.00 LG (32301527)
14	1	906781-01	PUMP ASSY,203,GPT P/D
15	1	906737-01	CARTRIDGE RELIEF VALVE

CAUTION

Do not over-tighten the terminal nuts on starter solenoid. For the load terminals, torque nuts to 40 lbs.-in. max. Torque the nuts on #10-32 control terminals 15-20 lbs.-in.

CAUTION

To prevent damage when installing 2-way valves, torque valve cartridge nut to 30 lbs.-in. max.

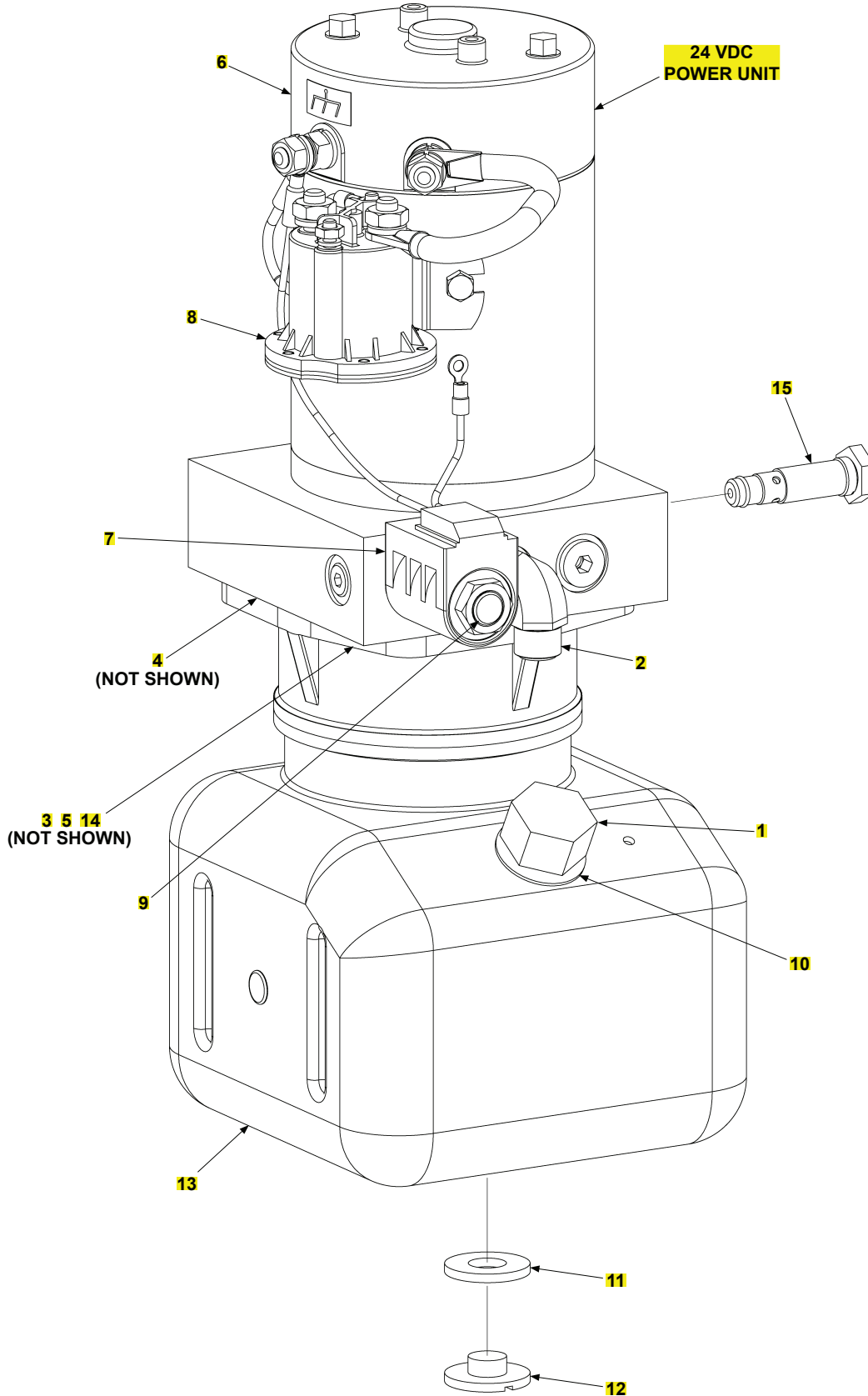

24 VDC POWER UNIT (GRAVITY DOWN)**LAST UPDATED
MAY 2017 to DEC 2020**

ITEM	QTY.	PART NO.	DESCRIPTION
REF	1	287072-01	24VDC POWER UNIT, GD
1	1	280806-01	FILLER, BREATHER
2	1	906707-01	ELBOW, NPSC,SAE #6 F/S O-R M-M
3	1	260261	OIL SEAL,PUMP
4	1	290061	SEAL SQUARE CUT PL RESERVOIR
5	1	290020	O-RING, KEPNER CHECK VALVE
6	1	290176-01	24VDC MOTOR W/OUT TERM SW
7	1	290211	24 VDC COIL, DOUBLE LEADS (PDL24) (39002187)
8	1	284080-02	SWITCH, SOLENOID ASSY, 24VDC
9	1	290215	VALVE 2P2W NC DELTA (38502314)
10	1	908016-01	GROMMET, RUBBER, .60 ID
11	1	290209	WASHER, .56 ID X 1.25 OD (61200504)
12	1	290208	PLUG, 9/16-18, PLASTIC TANK (35901162)
13	1	290207	RESERVOIR, PLASTIC, 8.00 LG (32301527)
14	1	906781-01	PUMP ASSY,203,GPT P/D
15	1	906737-01	CARTRIDGE RELIEF VALVE

CAUTION

Do not over-tighten the terminal nuts on starter solenoid. For the load terminals, torque nuts to 40 lbs.-in. max. Torque the nuts on #10-32 control terminals 15-20 lbs.-in.

CAUTION

To prevent damage when installing 2-way valves, torque valve cartridge nut to 30 lbs.-in. max.

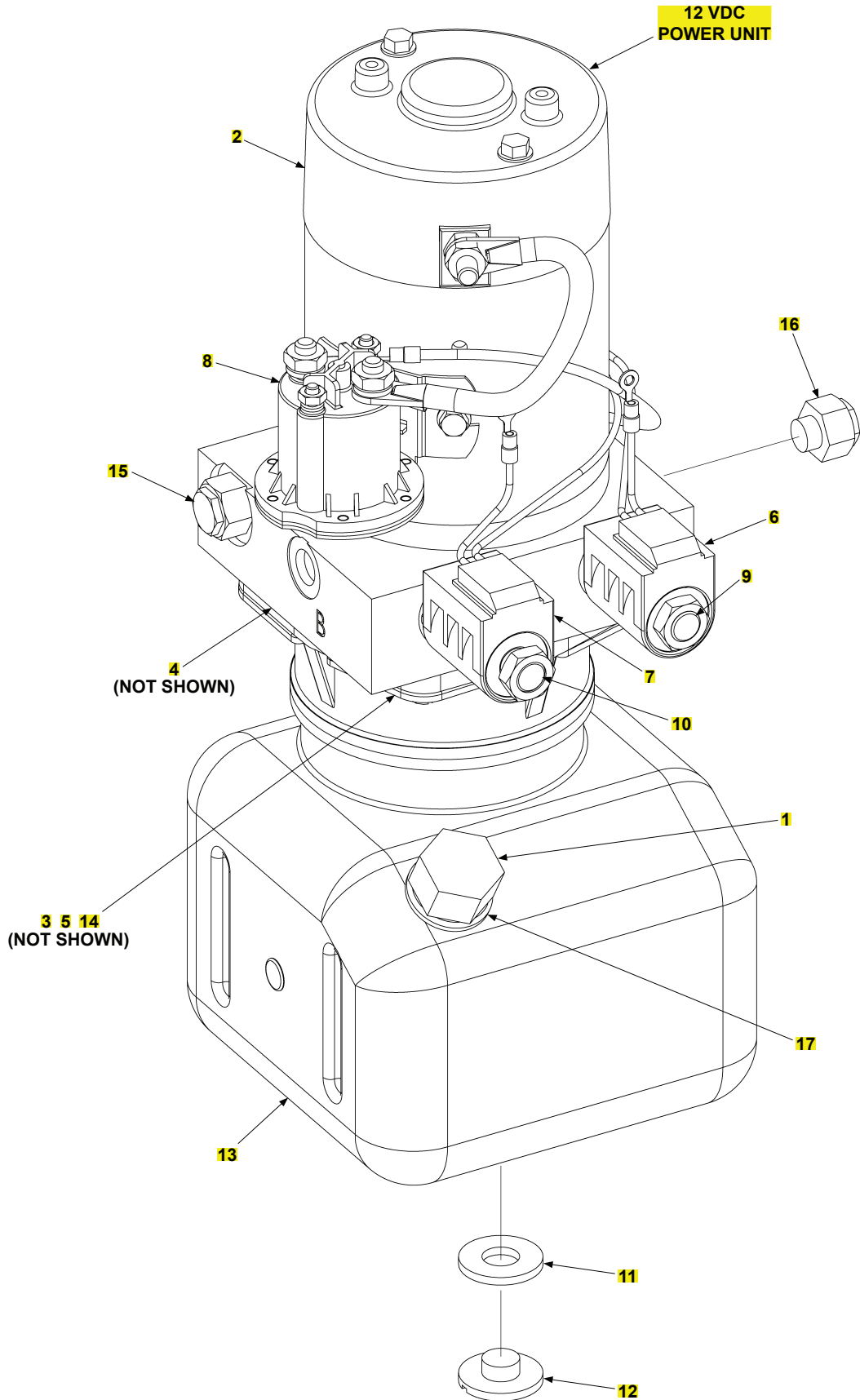

12 VDC POWER UNIT (POWER DOWN)**LAST UPDATED
MAY 2017 to DEC 2020**

ITEM	QTY.	PART NO.	DESCRIPTION
REF	1	287076-01	12VDC POWER UNIT,P/D,TUK-A-WAY
1	1	280806-01	FILLER, BREATHER
2	1	290177-01	12VDC MOTOR W/OUT TERM SW, P/D
3	1	260261	OIL SEAL,PUMP
4	1	290061	SEAL SQUARE CUT PL RESERVOIR
5	1	290020	O-RING, KEPNER CHECK VALVE
6	1	290213	12 VDC COIL, DOUBLE LEADS (PDL12) (39002189)
7	1	290212	12 VDC COIL, DOUBLE LEADS (DDL12) (39002188)
8	1	284080-01	SWITCH, SOLENOID ASSY
9	1	290215	VALVE 2P2W NC DELTA (38502314)
10	1	290047	VALVE CARTRIDGE 4WAY
11	1	290209	WASHER, .56 ID X 1.25 OD (61200504)
12	1	290208	PLUG, 9/16-18, PLASTIC TANK (35901162)
13	1	290214	RESERVOIR, PLASTIC, 8.00 LG (32301528)
14	1	906781-01	PUMP ASSY,203,GPT P/D
15	1	268174-01	RELIEF VALVE,ADJUST,1100PSI
16	1	906930-01	RELIEF VALVE "RV1" SET @ 2400 PSI
17	1	908016-01	GROMMET, RUBBER, .60 ID

NOTE: Preferred decal layout is shown. Decals on the Liftgate are attached at the factory. If vehicle does not permit this layout, decals in the manual and decal kit must be applied so that they are easily visible when approaching vehicle to operate Liftgate. Use good common sense when locating these decals on vehicle.

CAUTION
Always stand clear of platform area.

WARNING
Read this information carefully.

- Improper operation of this Liftgate can result in serious personal injury. If you do not have a copy of the operating instructions, please obtain them from your employer, distributor, or dealer before you attempt to operate Liftgate.
- If there are signs of improper maintenance, damage to vital parts, or slippery platform surface, do not use the Liftgate until these problems have been corrected.
- If you are using a pallet jack, be sure it can be maneuvered safely.
- Do not operate a forklift on the platform.
- Do not allow any part of yours or your helper's body to be placed under, within, or around any portion of the moving Liftgate, or its mechanisms, or in a position that would trap them between the platform and the ground or truck when the Liftgate is operated.
- If a helper is riding the platform with you, make sure you are both doing so safely and that you are not in danger of coming in contact with any moving or potentially moving obstacles.
- **USE GOOD COMMON SENSE**
- If load appears to be unsafe, do not lift or lower it.

SAFETY INSTRUCTIONS
Read all decals and operation manual before operating liftgate.

1. Do not use liftgate unless you have been properly instructed and have read, and are familiar with, the operating instructions.
2. Be certain vehicle is properly and securely braked before using the liftgate.
3. Always inspect this liftgate for maintenance or damage before using it. Do not use liftgate if it shows any sign of damage or improper maintenance.
4. Do not overload.
5. Make certain the area in which the platform will open and close is clear before opening or closing the platform.
6. Make certain platform area, including the area in which loads may fall from platform, is clear before and at all times during operation of liftgate.
7. This liftgate is intended for loading and unloading of cargo only. Do not use this liftgate for anything but its intended use.

WARNING
Liftgate hazards can result in crushing or falling.
Keep hands and feet clear of pinch points.
If riding liftgate, make sure load is stable and footing is solid.

Read and understand all instructions and WARNINGS before use.

1

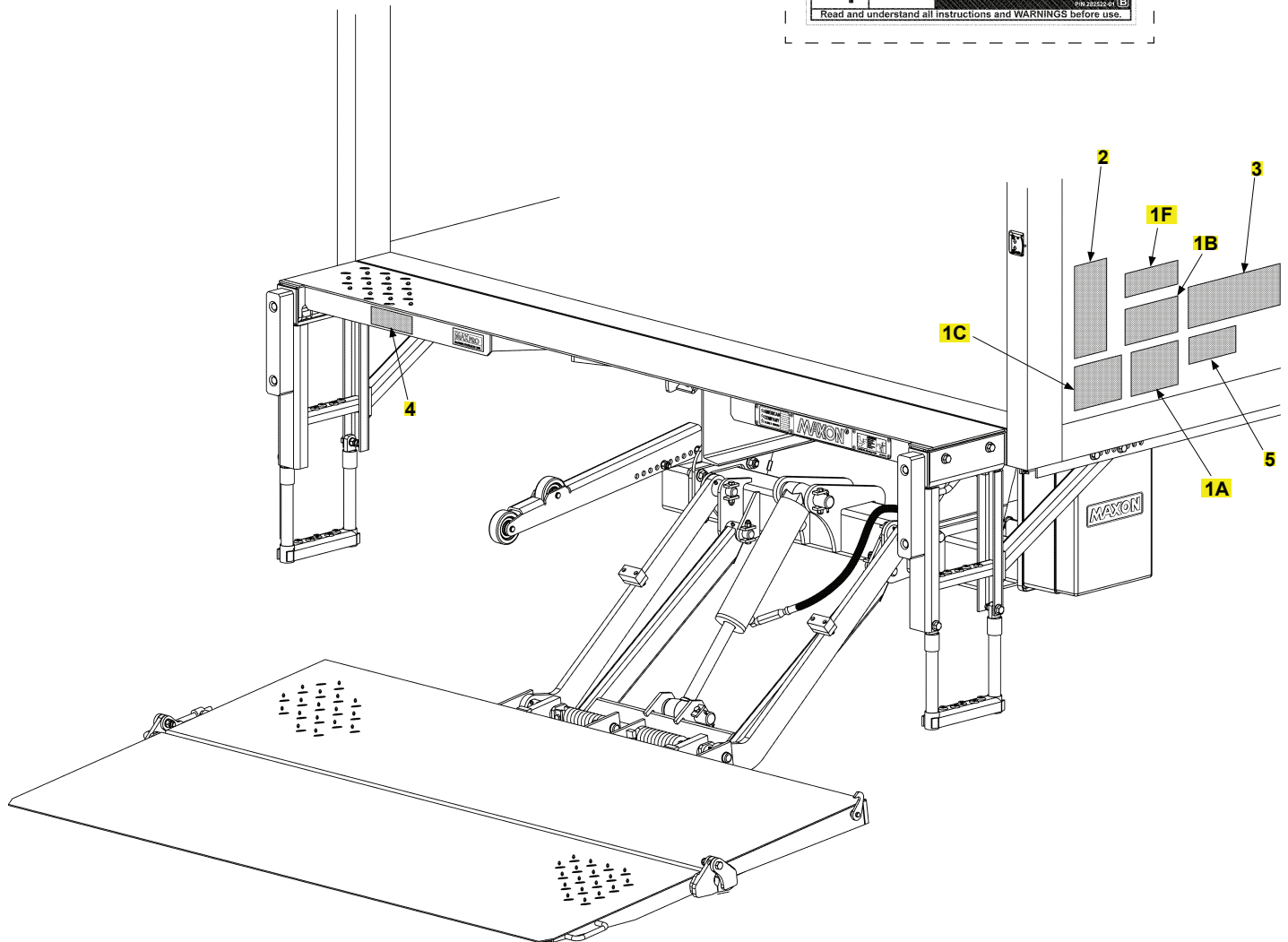

TE-25/30 DECAL**LAST UPDATED
MAY 2017 to DEC 2020**

ITEM	QTY.	PART NO.	DESCRIPTION
1	1	282522-01	DECAL SHEET,SM WARN & CAUTION
1A	1	282522-01	DECAL SHEET,SM WARN & CAUTION
1B	1	282522-01	DECAL SHEET,SM WARN & CAUTION
1C	1	282522-01	DECAL SHEET,SM WARN & CAUTION
1F	1	282522-01	DECAL SHEET,SM WARN & CAUTION
2	1	285800-01	DECAL, STD TUK-A-WAY OPER INSTRUC
3	1	282847-02	DECAL, WARNING,STOW,TUK-A-WAY
4	1	265736-03	DECAL WARNING PINCH HAZARD
5	1	220382	DECAL 2500# CAPACITY
		220388	DECAL 3000# CAPACITY 2X3.75