

M-16-11
REV. C
MAY 2024

Operation Manual Contains:

- Warnings
- Decal & Plate Locations
- Standard Control Locations
- Liftgate & Retention Ramp Operation

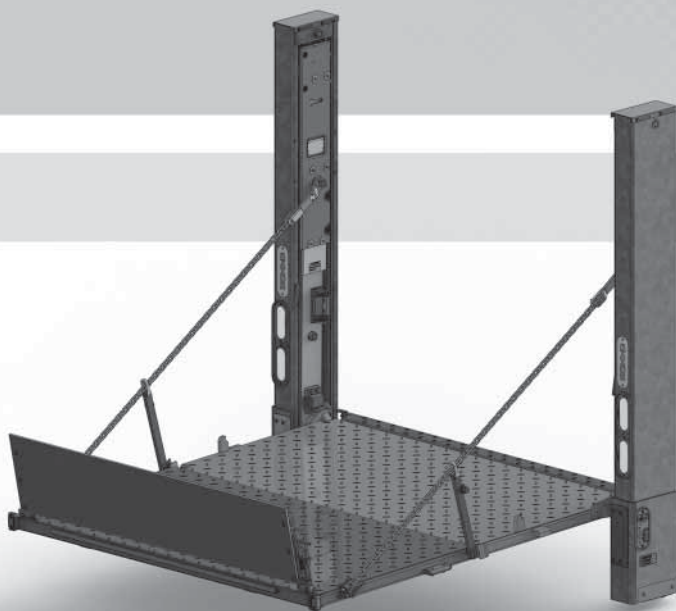

MAXON[®]
LIFT CORP.

To find maintenance information for your **BMR Liftgate**, go to www.maxonlift.com. Click the **PRODUCTS, COLUMNLIFT & BMR** buttons. Open the **Maintenance Manual** in the **PRODUCT DOCUMENTATION** window. For parts, click on the **PARTS PORTAL, COLUMNLIFT & BMR** buttons.

© MAXON Lift Corp. 2024

BMR

OPERATION MANUAL

KEEP THIS MANUAL IN CAB OF VEHICLE

Register your liftgate on line at www.maxonlift.com/htm/services/reg.htm. For a free copy of other manuals that pertain to this model liftgate, please visit our website at www.maxonlift.com or customer service at (800) 227-4116.

TABLE OF CONTENTS

SUMMARY OF CHANGES: M-16-11, REVISION C	5
WARNINGS	6
RECOMMENDED DAILY OPERATION CHECKS	8
DECALS & PLATES	10
STANDARD CONTROL LOCATIONS	12
POWER DOWN CONTROLS (IF EQUIPPED)	13
PUMP BOX CONTROLS.....	14
FORKLIFT ADVISORY	15
LOADING VEHICLE	16
OPENING THE PLATFORM	16
LOWERING THE PLATFORM	16
OPENING THE RETENTION RAMP.....	17
POSITIONING LOAD	18
RAISING & UNLOADING PLATFORM.....	19
UNLOADING VEHICLE	21
OPENING THE PLATFORM	21
LOWERING THE PLATFORM	21
OPENING RAMP TO RETENTION POSITION.....	22
RAISING THE PLATFORM	23
POSITIONING LOAD	24
LOWERING & UNLOADING PLATFORM.....	25
STOWING PLATFORM	26

TABLE OF CONTENTS - Continued

STOW RETENTION RAMP.....	26
STOW PLATFORM	26
USING CART STOPS (IF EQUIPPED)	28
USING AUTO CART STOPS (IF EQUIPPED)	31
DOCK LOADING & UNLOADING	34
LOWER PLATFORM BELOW DOCK LEVEL.....	34

SUMMARY OF CHANGES: M-16-11, REVISION C

PAGE	DESCRIPTION OF CHANGE
COVER	Updated REV. and date of release.
10, 16, 21, 26	Changed reference to runner alignment decal to yellow marker on LH column.
11	Updated operation decal to latest version.
14	Updated pump box to show rubber latches.
17, 19, 22, 25, 26	Repositioned safety lights on sides of platform facing outward.

WARNING

1. Incorrect operation of this Liftgate can result in serious personal injury. Comply with **WARNINGS** and Liftgate operating instructions in this manual. Do not allow untrained persons or children to operate the Liftgate. If you need to replace an **Operation Manual**, additional copies are available from:

MAXON Lift Corp. Customer Service
11921 Slauson Ave
Santa Fe Springs, CA 90670
(800) 227-4116
2. Do not exceed rated **load capacity** of the Liftgates which is **3500 lbs. for model BMR-3500, 4400 lbs. for model BMR-44, 5500 lbs. for model BMR-55, and 6600 lbs. for model BMR-66.**
3. Do not allow any part of your body to be placed under, within, or around any portion of the moving Liftgate or its mechanisms, or in a position that would trap them between the platform and the floor of truck body (or between platform and the ground) when Liftgate is operated.
4. Consider the safety and location of bystanders and location of nearby objects when operating the Liftgate. Stand to one side of platform while operating the Liftgate. Be certain that the area the Liftgate will move through during operation is clear of all obstacles.
5. Comply with all attached instruction decals and warning decals.
6. Keep decals clean and legible. If decals are illegible or missing, have them replaced. **Get free replacement decals from Maxon.**
7. **Never drive a forklift on the Liftgate platform.**
8. Do not move vehicle unless Liftgate is correctly stowed.
9. **Correctly stow platform when not in use. Extended platforms could create a hazard for people and vehicles passing by.**
10. A correctly installed Liftgate will operate smoothly and reasonably quiet. The only noticeable noise, during Liftgate operation, is from the power unit while the platform is being opened (SD models only), lowered (power down models only), raised, or closed. Listen for scraping, grating and binding noises and have the problem corrected before continuing to operate the Liftgate.
11. Above all, **USE GOOD COMMON SENSE** when operating this Liftgate.
12. Never use a cell phone while operating the Liftgate.

THIS PAGE INTENTIONALLY LEFT BLANK

RECOMMENDED DAILY OPERATION CHECKS

NOTE: Before you check the Liftgate, park vehicle on flat ground and set the parking brake.

NOTE: If any of the following operation checks reveal a need to service or repair Liftgate, do not operate the Liftgate until a qualified mechanic services or repairs the Liftgate.

Before operating the Liftgate, the operator should do the following:

- Make sure batteries are fully charged, battery terminal connections are clean and tight, and battery box is undamaged.
- Make sure cab cutoff switch is **ON**, if equipped.
- Visually check that pump cover is latched on securely and undamaged. Look for hydraulic fluid leaking from the pump box.
- Follow the routing of hydraulic hoses from cylinders to pump box. Make sure all hoses are connected at both ends and there are no cracks, chafing, and fluid leaks.
- Visually check that standard and optional controls are in place and undamaged.
- Visually check that all decals are in place (see **DECALS** page). Make sure decals are legible, clean, and undamaged.

Use the operation instructions in this manual to unfold the platform and lower it to the ground.

- Check for smooth operation as platform unfolds and as runners lower the platform to the ground.
- Check main frame, extension plate, columns, runners and platform openers for cracks and bends. Make sure platform chains are undamaged and connected securely at both ends. Also, make sure all bolts and pins are in place and undamaged.
- Check platform and flipover for cracks, holes, and bends on the load-carrying surfaces and side plates. Also, make sure retention ramps and carts stops (if equipped) are undamaged and operate smoothly.
- Make sure load-carrying surfaces on extension plate, platform, flipover, and retention ramp (if equipped) are clean (no oil, debris, or corrosion).
- Check for fluid leaks from hydraulic cylinders.

Use the operation instructions in this manual to operate the Liftgate through one cycle without a load on the platform. Raise the platform to vehicle bed height. Next, lower the platform to ground level.

- When raising and lowering platform, listen for unusual noises and look for a “jerking” motion or uneven movement at LH and RH sides of the platform. Uneven movement should not exceed 1”.
- With platform at bed height, make sure the LH and RH platform chains feel even in tightness.
- Retention ramps (if equipped) release, unfold and fold smoothly, and remains in ramp, retention, and stowed positions until intentionally moved.
- Carts stops (if equipped) release, open, and close smoothly and remain so until intentionally opened or stowed.

If service or repairs are not required (or if completed), stow platform for transport.

DECALS & PLATES

NOTE: Ensure there is no residue, dirt, or corrosion where decals are attached. If necessary, clean surface before attaching decals.

NOTE: Decals on the Liftgate are attached at the factory.

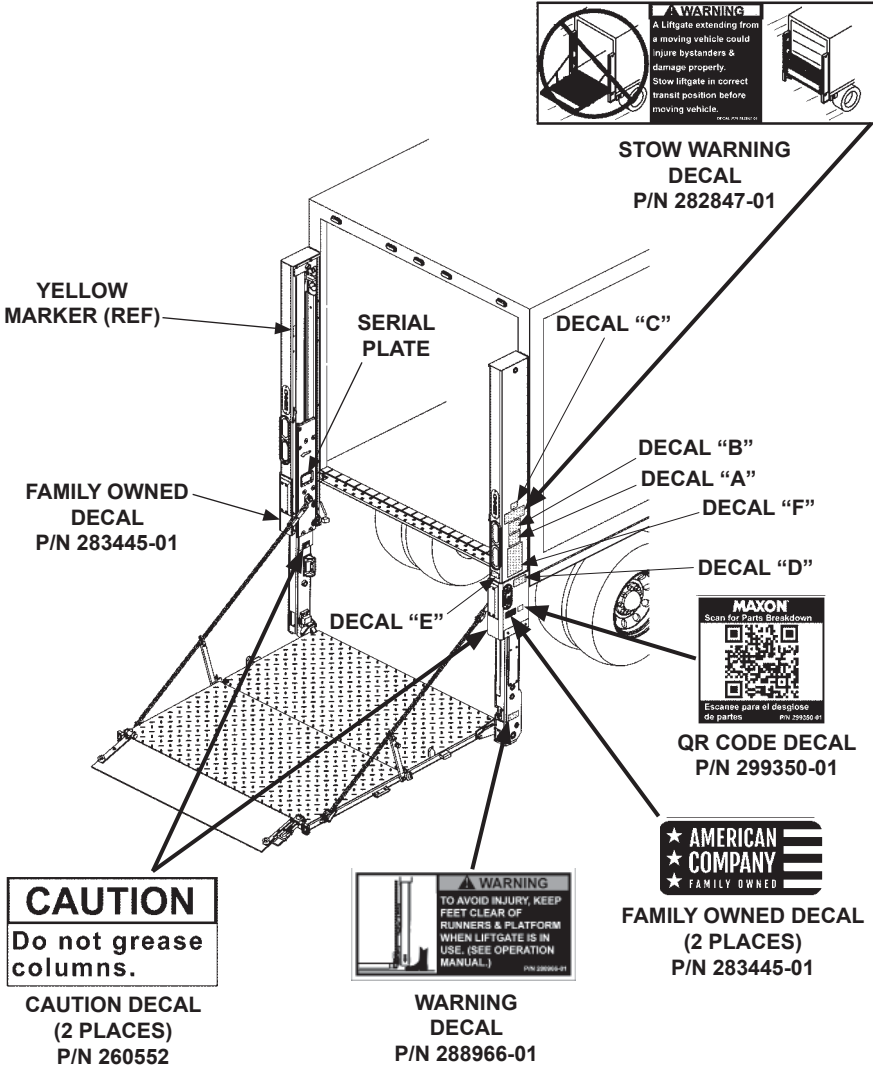

FIG. 10-1

⚠ WARNING
Read this information carefully.

- Improper operation of this Liftgate can result in serious personal injury. If you do not have a copy of the operating instructions, please obtain them from your employer, distributor, or lessor before you attempt to operate Liftgate.
- If there are signs of improper maintenance, damage to vital parts, or slippery platform surface, do not use the Liftgate until these problems have been corrected.
- If you are using a pallet jack, be sure it can be maneuvered safely.
- Do not operate a forklift on the platform.
- Do not allow any part of yours or your helper's body to be placed under, within, or around any portion of the moving Liftgate, or its mechanisms, or in a position that would trap them between the platform and the ground or truck when the Liftgate is operated.
- If a helper is riding the platform with you, make sure you are both doing so safely and that you are not in danger of coming in contact with any moving or potentially moving obstacles.
- **USE GOOD COMMON SENSE.**
- If load appears to be unsafe, do not lift or lower it.

For a free copy of other manuals that pertain to this model Liftgate, please visit our website at www.maxonlift.com or call Customer Service at (800) 227-4116

SAFETY INSTRUCTIONS
Read all decals and operation manual before operating liftgate.

1. Do not use liftgate unless you have been properly instructed and have read, and are familiar with, the operating instructions.
2. Be certain vehicle is properly and securely braked before using the liftgate.
3. Always inspect this liftgate for maintenance or damage before using it. Do not use liftgate if it shows any sign of damage or improper maintenance.
4. Do not overload.
5. Make certain the area in which the platform will open and close is clear before opening or closing the platform.
6. Make certain platform area, including the area in which loads may fall from platform, is clear before and at all times during operation of liftgate.
7. This liftgate is intended for loading and unloading of cargo only. Do not use this liftgate for anything but its intended use.

THE MAXIMUM CAPACITY OF THIS LIFT IS
___ LB [___ KG]
WHEN THE LOAD IS CENTERED ON THE LOAD CARRYING PLATFORM

(REFER TO TABLE 11-1)

⚠ CAUTION
Always stand clear of platform area.

⚠ WARNING
Liftgate hazards can result in crushing or falling.
Keep hands and feet clear of pinch points.
If riding liftgate, make sure load is stable and footing is solid.

Read and understand all instructions and WARNINGS before use.

OPERATING INSTRUCTIONS

Scan this QR code to see operation manual or video.

OPERATE	STOW
<p>1 LOWER RUNNERS TO LINE UP YELLOW ARROW WITH YELLOW STRIPE. THIS SHOWS PLATFORM IS CLEAR TO UNFOLD.</p>	<p>1 RAISE PLATFORM TO LINE UP YELLOW ARROW WITH YELLOW STRIPE. THIS SHOWS PLATFORM IS CLEAR TO FOLD.</p>
<p>2 UNFOLD PLATFORM.</p>	<p>2 FOLD PLATFORM.</p>
<p>3 1 - LOWER PLATFORM. IF IT IS SLOW TO LOWER & LIFTGATE IS POWER DOWN EQUIPPED, PUSH POWER DOWN BUTTON. 2 - RAISE PLATFORM. POWER DOWN BUTTON (IF EQUIPPED)</p>	<p>3 RAISE RUNNERS TO STOW PLATFORM.</p>

DECAL SHEET
FIG. 11-1

MODEL	ORDER P/N	DECAL "C"
BMR-35	289163-01	3500 LBS. [1600 KG]
BMR-44	289163-02	4400 LBS. [2000 KG]
BMR-55	289163-03	5500 LBS. [2500 KG]
BMR-66	289163-04	6600 LBS. [3000 KG]

DECAL SHEET PART NUMBERS
TABLE 11-1

STANDARD CONTROL LOCATIONS

GROUND ACCESS - COLUMN SWITCH

Toggle switches on column switch (FIG. 12-1A) let operator raise (UP), lower (DOWN), FOLD, and UNFOLD the platform (FIG. 12-1) while standing on the ground.

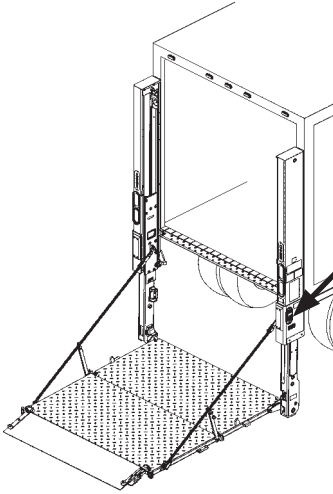

FIG. 12-1

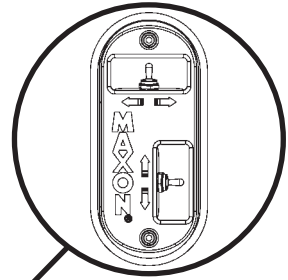

FIG. 12-1A

PLATFORM ACCESS - RUNNER SWITCH

Toggle switch (FIG. 12-2A) on RH runner lets operator raise (UP) and lower (DOWN) the platform (FIG. 12-2) only. Switch stays within reach when operator rides platform UP and DOWN.

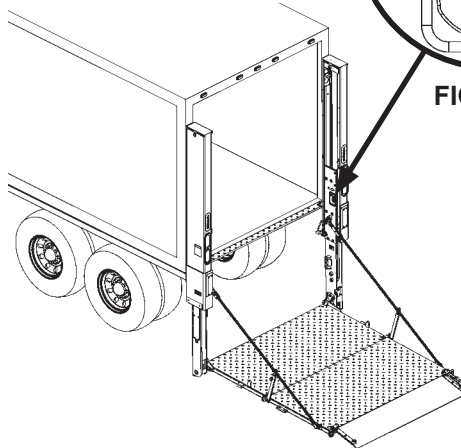

FIG. 12-2B

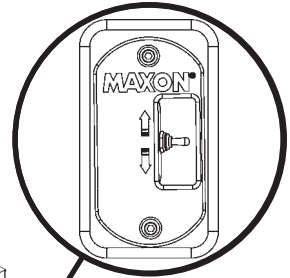

FIG. 12-2A

POWER DOWN CONTROLS (IF EQUIPPED)

GROUND ACCESS - COLUMN SWITCH

POWER DOWN button (if equipped) on column switch (FIG. 13-1A) lets operator lower platform by pressing the **POWER DOWN** button once and pushing and holding the toggle switch (**DOWN**) (FIG. 13-1), while standing on the ground. The **POWER DOWN** button (FIG. 13-1A) illuminates to indicate the power down function is activated.

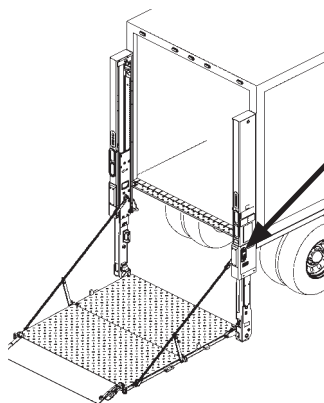

FIG. 13-1

POWER DOWN BUTTON

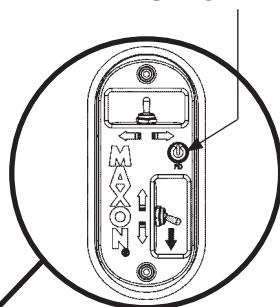

FIG. 13-1A

PLATFORM ACCESS - RUNNER SWITCH

POWER DOWN button (if equipped) on runner switch (FIG. 13-2A) lets operator lower platform by pressing the **POWER DOWN** button once and pushing and holding the toggle switch (**DOWN**) (FIG. 13-2B), while standing on the platform. The **POWER DOWN** button (FIG. 13-2A) illuminates to indicate the power down function is activated.

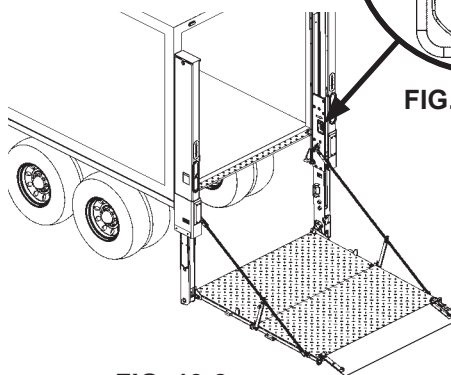

FIG. 13-2

POWER DOWN BUTTON

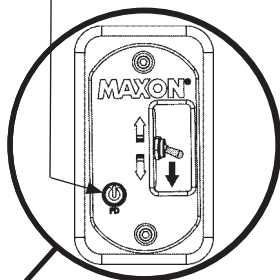
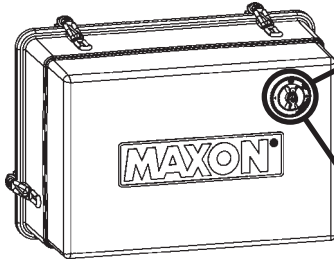

FIG. 13-2A

PUMP BOX CONTROLS

MASTER SELECT SWITCH

The master select switch (FIGS. 14-1, 14-1A and 14-1B) applies or removes battery power from the pump(s). For a single pump box (FIGS. 14-1A and 14-1B), turn the **MASTER SELECT SWITCH** to 1 to operate Liftgate.



SINGLE PUMP BOX
FIG. 14-1

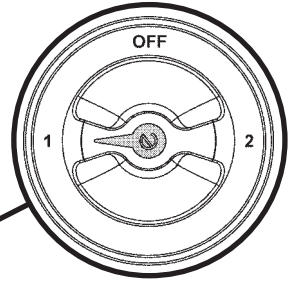

MASTER SELECT SWITCH (ON)
(PUMP 1 SELECTED)
FIG. 14-1A

If the Liftgate is equipped with a dual pump box, the **MASTER SELECT SWITCH (FIG. 14-1A)** can be used to connect battery power to either pump 1 or pump 2 to power Liftgate. To remove battery power from pumps 1 and 2, turn switch **OFF (FIG. 14-1B)**.

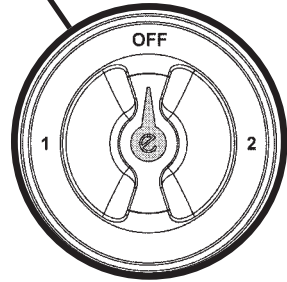

MASTER SELECT SWITCH OFF
FIG. 14-1B

FORKLIFT ADVISORY

⚠ WARNING
Keep forklift OFF of platform.

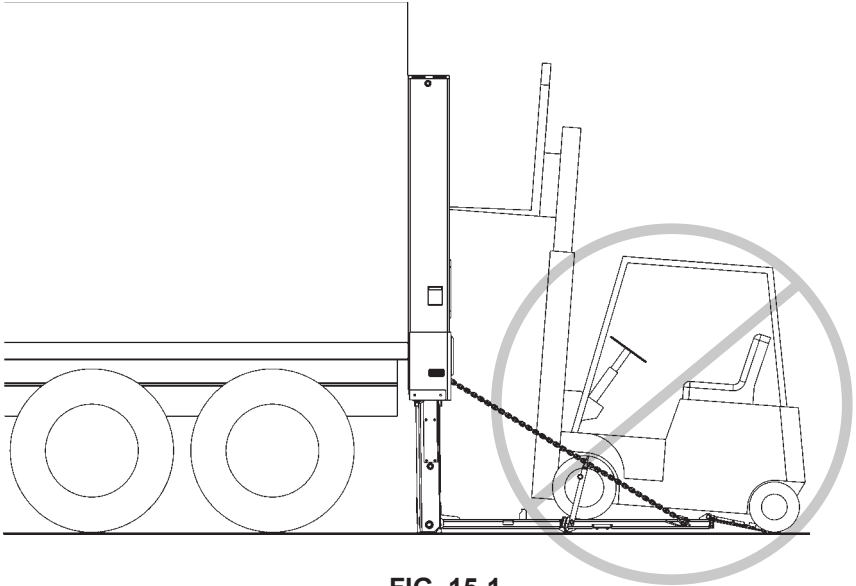

FIG. 15-1

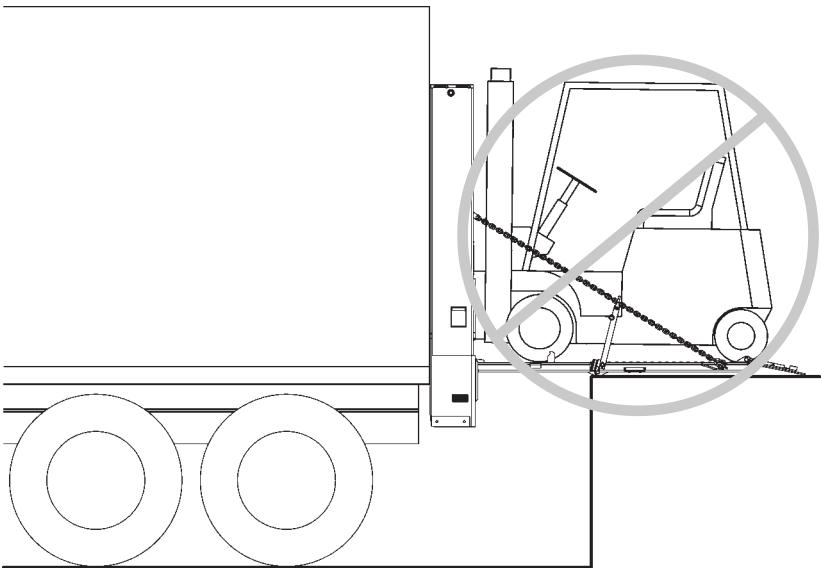
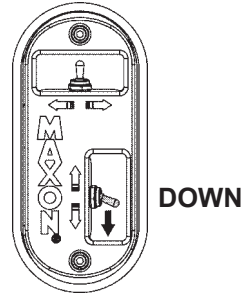

FIG. 15-2

LOADING VEHICLE OPENING THE PLATFORM

NOTE: The 2 platform flashing lights are flashing when platform is unfolding and unfolded. The lights stop flashing when the platform is folded/stowed.

Push toggle switch to **DOWN** position (**FIG. 16-1**) to lower platform until runner arrow and yellow marker are about even (**FIG. 16-2A**). Platform will be released from the locking wedges on the Liftgate column. Next, use column switches **1** and **2** to **UNFOLD** platform (**FIG. 16-2**). Hold both toggle switches until platform reaches the unfolded (horizontal) position and then release the switches.



**COLUMN SWITCH
FIG. 16-1**

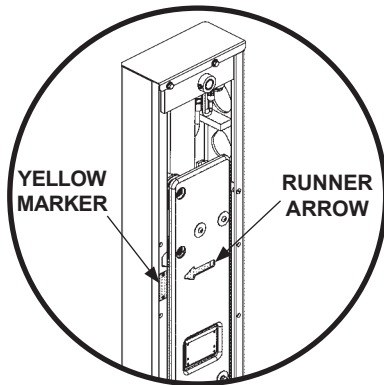

FIG. 16-2A

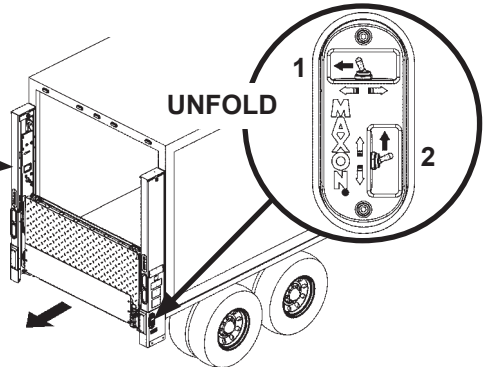

FIG. 16-2

LOWERING THE PLATFORM

To lower platform to the ground, use column switch as shown in **FIG. 16-3**. Release toggle switch when platform reaches the ground.

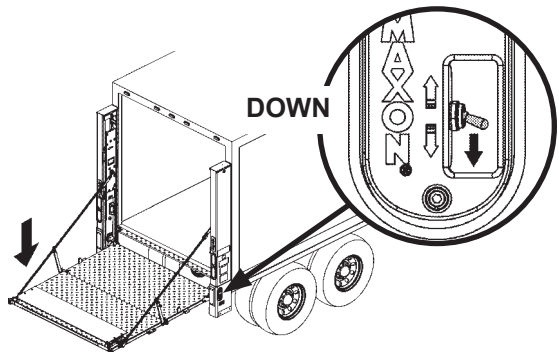

FIG. 16-3

OPENING THE RETENTION RAMP

To unfold retention ramp, pull lock in direction of arrow (**FIG. 17-1**) and rotate ramp to the ground (**FIG. 17-2**).

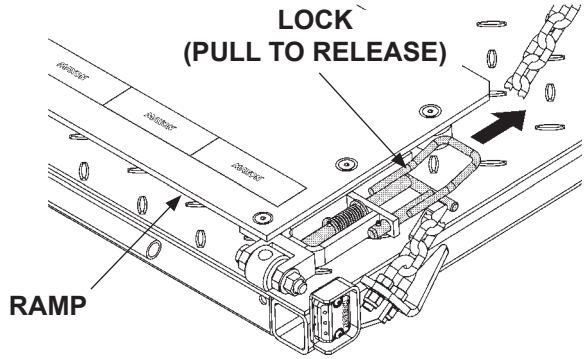

FIG. 17-1

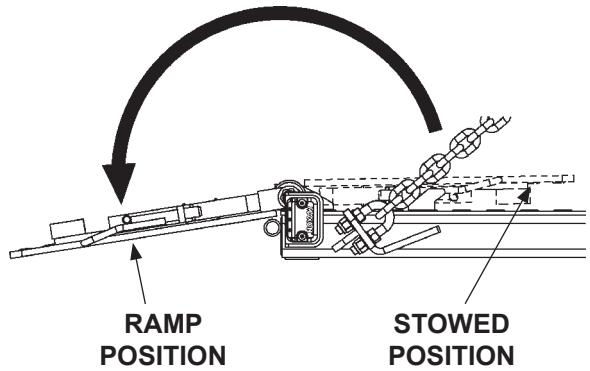

FIG. 17-2

LOADING VEHICLE - Continued POSITIONING LOAD

⚠ WARNING

A load should never extend past the edges of the platform. Do not place unstable loads on platform and do not allow load to exceed lifting capacity of Liftgate. If standing on platform, do not allow your feet to extend beyond inboard edge of platform.

Place all loads as close as possible to the inboard edge of the platform with heaviest part toward the truck body as shown in **FIG. 18-1**. Move loads across the ramp (**FIG. 18-1**) to the platform, but never rest or raise loads on the ramp. If standing on platform with the load, stand in the footprint area shown and comply with the preceding **WARNING**.

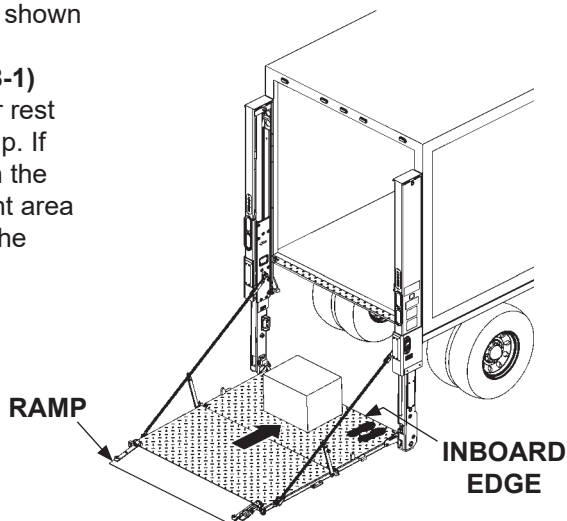

**LOADING PLATFORM AT GROUND LEVEL
FIG. 18-1**

RAISING & UNLOADING PLATFORM

CAUTION

A ramp in retention position can trip you when stepping over it. To prevent possible injury, get on the platform before putting the ramp in retention position.

1. Fold ramp until it locks in retention position (FIGS. 19-1A & 22-2).

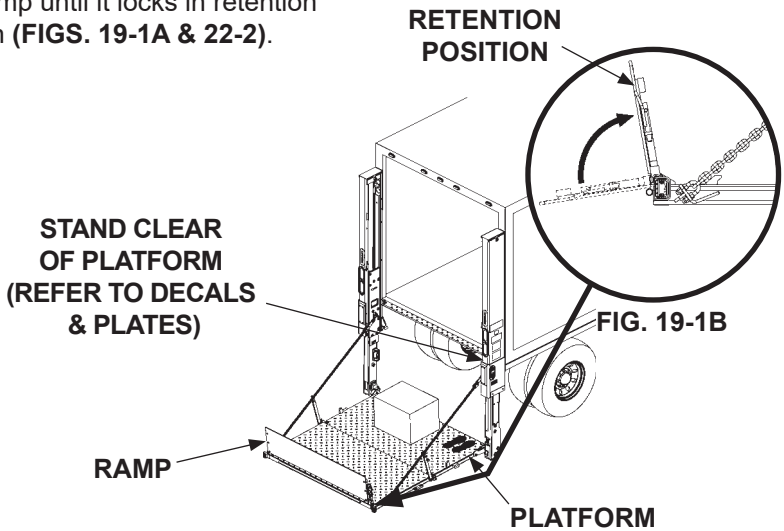
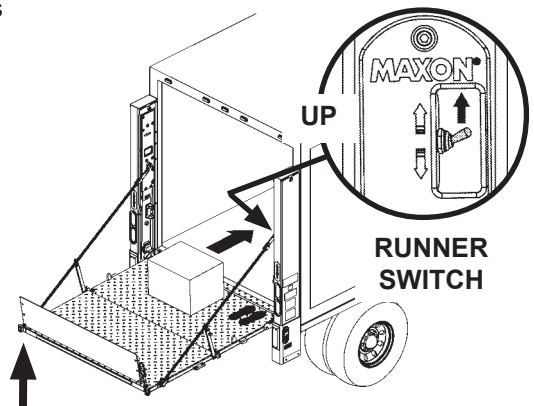

FIG. 19-1A

2. Use runner switch to raise (UP) platform from ground level to bed height (FIG. 19-2). Release switch when platform reaches bed height.



3. Carefully move the load into vehicle (FIG. 19-2).

MOVING LOAD INTO VEHICLE
FIG. 19-2

LOADING VEHICLE - Continued

RAISING & UNLOADING PLATFORM - Continued

4. Use runner switch to lower the platform to ground level (FIG. 20-1).

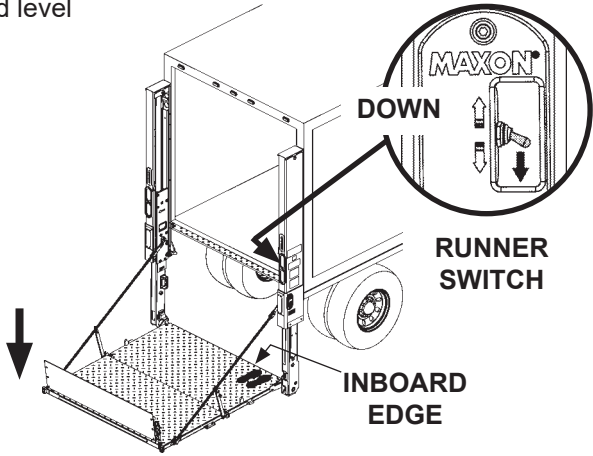
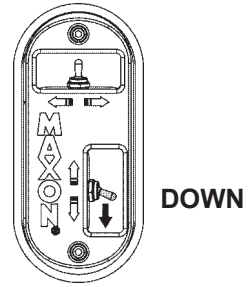

FIG. 20-1

5. If there are more loads to put in vehicle, repeat the previous **LOADING VEHICLE** steps for each load. When loading is finished, use **STOWING PLATFORM** procedure in this manual.

UNLOADING VEHICLE OPENING THE PLATFORM

Push column **UP/DOWN** toggle switch to **DOWN** position (**FIG. 21-1**) to lower platform (**FIG. 21-2**) until runner arrow and yellow marker plate are about even (**FIG. 21-2A**). Platform will be released from the locking wedges on the Liftgate column. Next, use column switches **1** and **2** to **UNFOLD** platform (**FIG. 21-2A**). Hold both toggle switches until platform reaches the unfolded (horizontal) position and then release the switches.



COLUMN SWITCH
FIG. 21-1

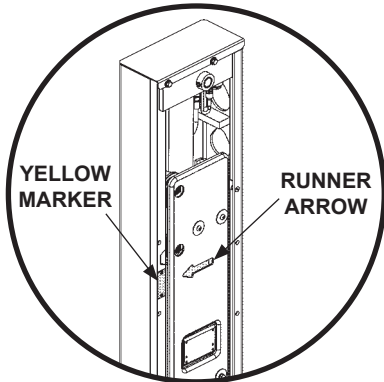

FIG. 21-2A

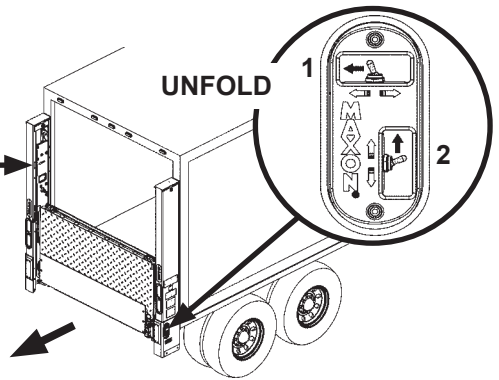

FIG. 21-2

LOWERING THE PLATFORM

To lower platform to the ground, use runner switch as shown in **FIG. 21-3**. Release toggle switch when platform reaches the ground.

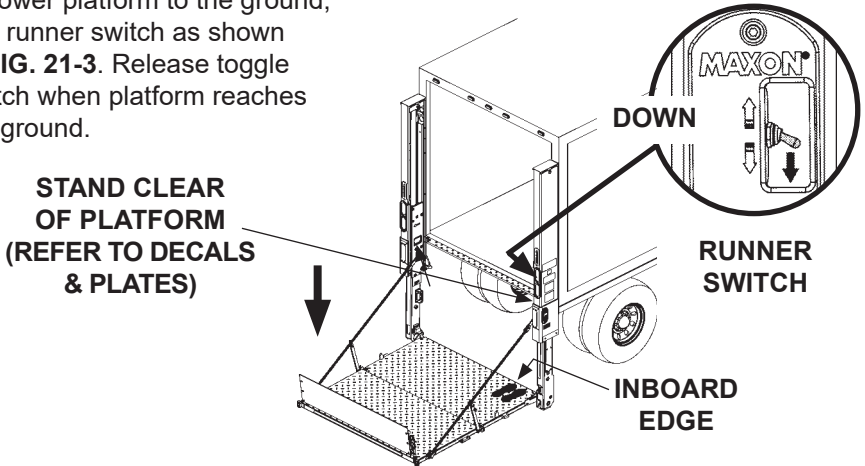

FIG. 21-3

UNLOADING VEHICLE - Continued

OPENING RAMP TO RETENTION POSITION

CAUTION

A ramp in retention position can trip you when stepping over it. To prevent possible injury, get on the platform before putting the ramp in retention position.

To unfold retention ramp, pull lock mechanism in direction of arrow (**FIG. 22-1**) and lift the retention ramp until it locks in the retention position (**FIG. 22-2**).

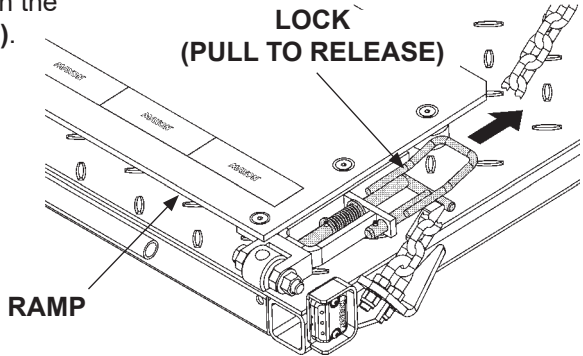

FIG. 22-1

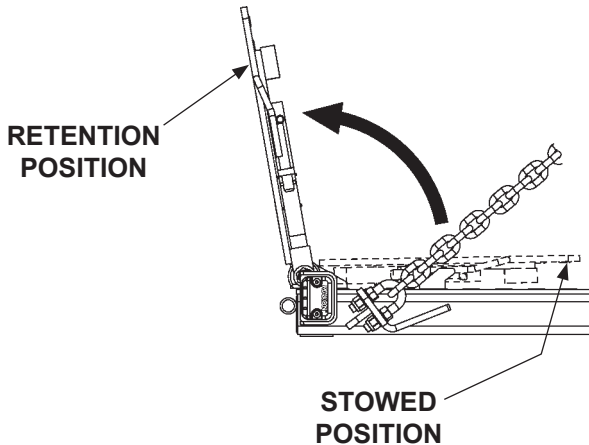

FIG. 22-2

RAISING THE PLATFORM

Use runner switch to raise platform (FIG. 23-1) from ground level to bed height. Release switch when platform reaches bed height.

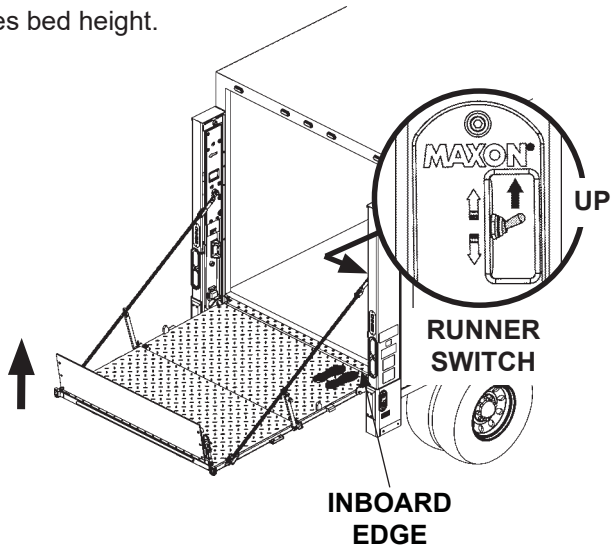

FIG. 23-1

UNLOADING VEHICLE - Continued POSITIONING LOAD

⚠ WARNING

A load should never extend past the edges of the platform. Do not place unstable loads on platform and do not allow load to exceed lifting capacity of Liftgate. If standing on platform, do not allow your feet to extend beyond inboard edge of platform.

⚠ WARNING

Pulling the load from vehicle to platform can result in a fall from platform and serious injury. When unloading vehicle, always push the load out on the platform.

Load the platform at bed level (**FIG. 24-1**) as follows. Push load out of the vehicle to correct position on the platform. Place all loads as close as possible to the inboard edge of the platform with heaviest part toward the vehicle body as shown in **FIG. 24-1**. If standing on platform with the load, stand in the footprint area shown and comply with the **WARNING** at the top of this page.

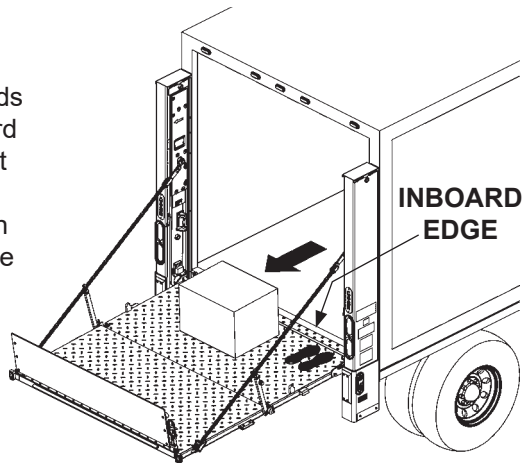

PUSHING LOAD ON PLATFORM
FIG. 24-1

LOWERING & UNLOADING PLATFORM

WARNING

Before lowering platform, make sure area surrounding platform is clear of people and objects. If standing on platform, do not allow your feet to extend beyond inboard edge of platform.

1. Use runner switch to lower platform to the ground (**FIG. 25-1**). Release switch when platform reaches ground level.

2. Pull up on lock mechanism and lower retention ramp to the ramp position (**FIG. 25-1A**).

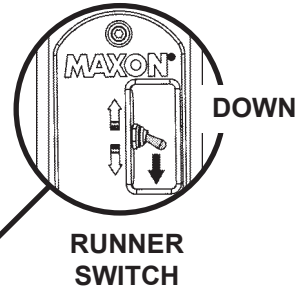

STAND CLEAR OF PLATFORM (REFER TO DECALS & PLATES)

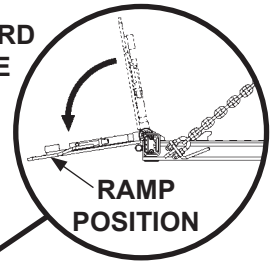
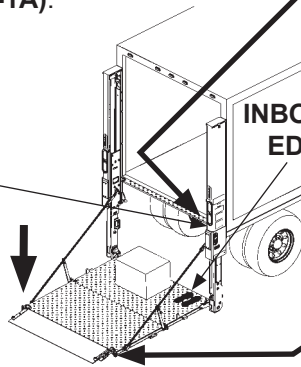
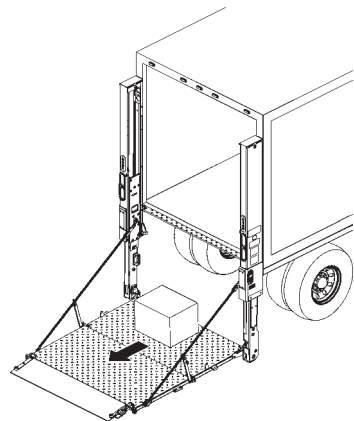

FIG. 25-1A

FIG. 25-1

3. Carefully move load off platform (**FIG. 25-2**) and then move it to a place where it will not become a hazard for people and other vehicles. If there is more to unload from vehicle, repeat the previous **UNLOADING VEHICLE** steps for each load. When unloading is finished, use **STOWING PLATFORM** procedure in this manual.



MOVING LOAD OFF PLATFORM
FIG. 25-2

STOWING PLATFORM STOW RETENTION RAMP

Push retention ramp to stowed position as shown in **FIGS. 26-1 & 26-1A**.

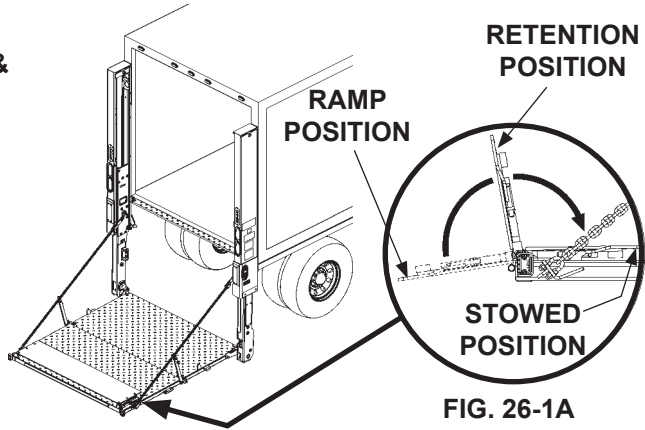

FIG. 26-1

STOW PLATFORM

CAUTION

Platform and bottom stops could be damaged if platform is folded with heel below the column bottom stops. Bottom stops will interfere with folded platform being raised to up position. Prevent damage by aligning arrow decals on column & runner before folding platform. Then, platform heel will be above the bottom stops.

1. Use the column switch to raise (UP) platform (FIG. 26-2) until runner arrow and yellow marker plate on LH column are aligned (FIG. 26-2A).

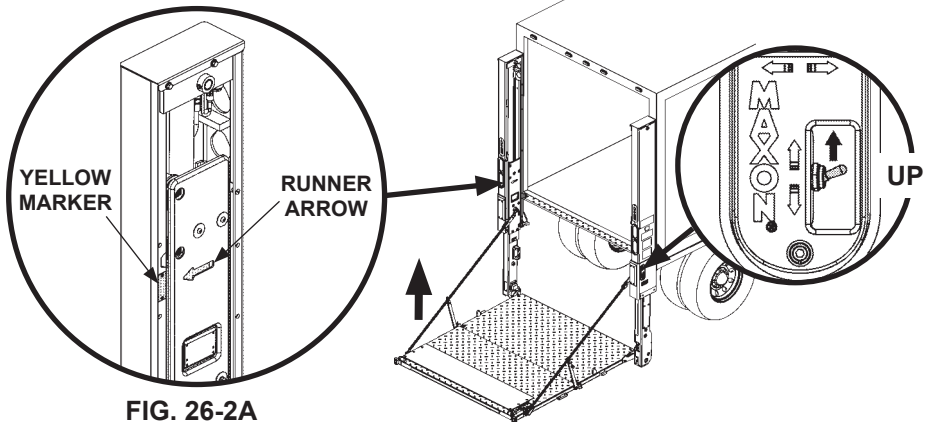

FIG. 26-2A

FIG. 26-2

NOTE: The 2 platform flashing lights are flashing when platform is unfolding and unfolded. The lights stop flashing when the platform is folded/stowed.

2. Hold both column switches 1 and 2 to **FOLD** platform (FIG. 27-1).

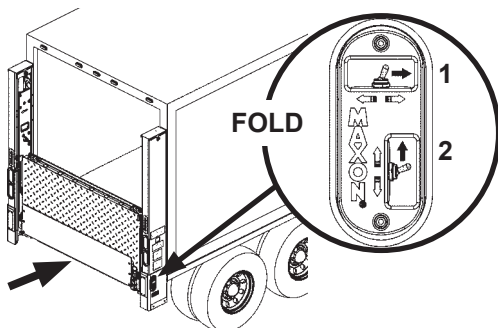
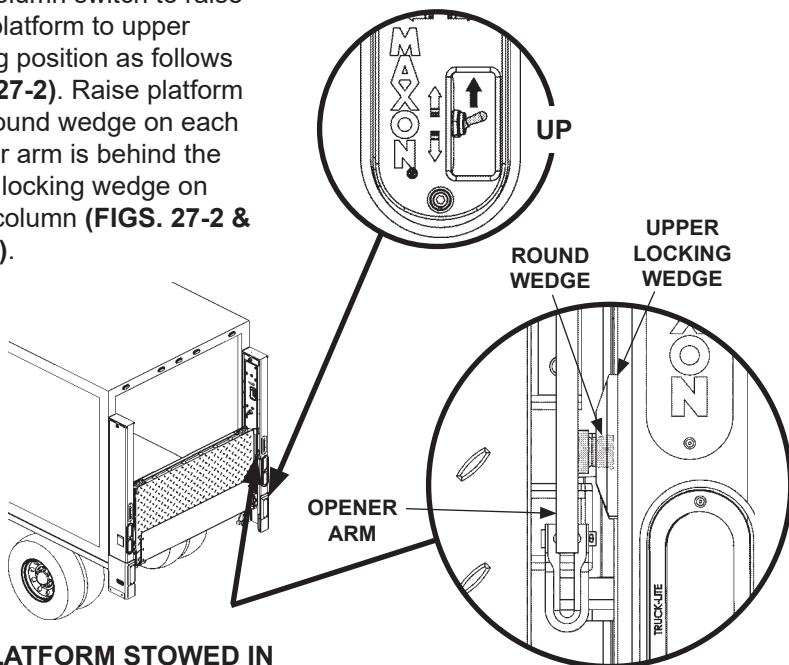

FIG. 27-1

⚠ WARNING

Upper locking wedges must be engaged before moving vehicle.

3. Use column switch to raise (UP) platform to upper locking position as follows (FIG. 27-2). Raise platform until round wedge on each opener arm is behind the upper locking wedge on each column (FIGS. 27-2 & 27-2A).



PLATFORM STOWED IN UPPER LOCKED POSITION
FIG. 27-2

UPPER LOCKING WEDGE ENGAGED (CHAIN REMOVED FROM VIEW)
FIG. 27-2A

USING CART STOPS (IF EQUIPPED)

⚠ CAUTION

To prevent injuries caused by tripping and falling, make sure cart stops are closed before walking on and off outboard end of platform.

NOTE: Some Liftgates are equipped with single or dual cart stops. Cart stops prevent loaded carts from rolling off outboard end of platform. Single cart stops are 1 section, about the same as overall width of platform, and operate with one set of controls. Dual cart stops are 2 identical sections, with a combined width about the same as overall width of platform, and each is independently operated with separate controls (1 set of controls per cart stop). The following procedure shows dual cart stops. A single cart stop operates the same way.

NOTE: Cart stops are usually closed when not in use. If you find the carts stops are already open when rolling a load from the ground to the platform, you may roll the load over the cart stop. The cart stop will close temporarily as the load crosses and reopen when the load is off the cart stop.

1. At ground level, move load on platform with cart stops as shown in **FIG. 28-1**.

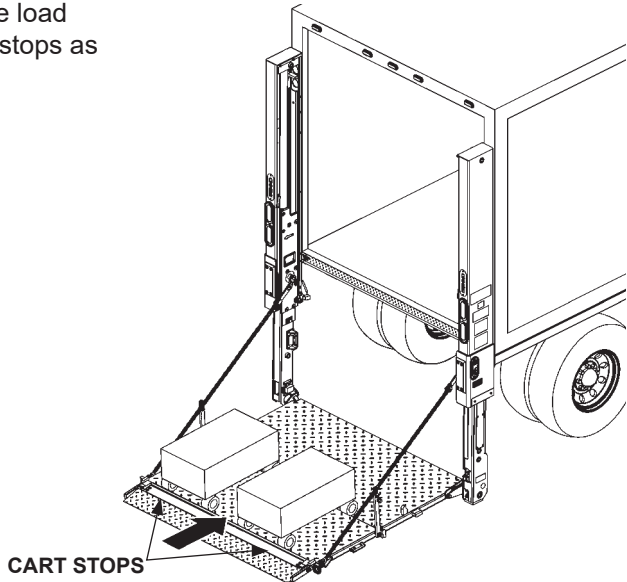

**LOADING PLATFORM AT GROUND LEVEL
(CART STOPS CLOSED)
FIG. 28-1**

NOTE: Cart stops are kept open by a cart stop lock.

2. Open cart stops by pushing the cart stop lock down with your foot (FIGS. 29-1 and 29-1A). Next, position cart(s) and stand in the footprint area as shown in FIG. 29-1.

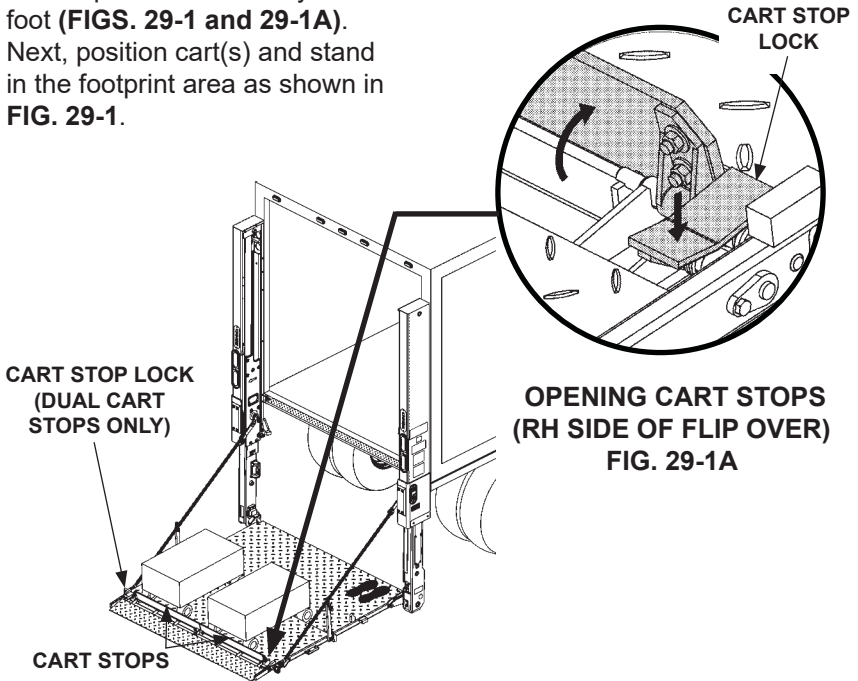

**OPENING CART STOPS
(RH SIDE OF FLIP OVER)
FIG. 29-1A**

**LOADING PLATFORM AT GROUND LEVEL
(CART STOPS OPEN)
FIG. 29-1**

3. Raise the platform to bed level (FIG. 29-2). Move the load off the platform into the vehicle body (FIG. 29-2).

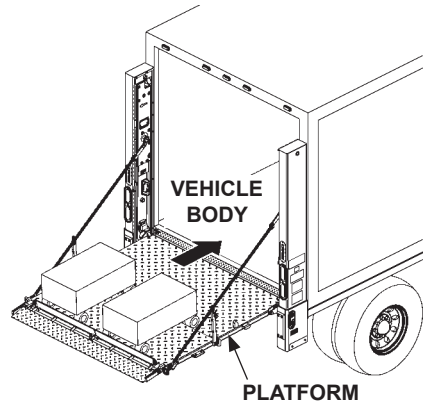

**UNLOADING PLATFORM AT BED LEVEL
(DUAL CART STOPS OPEN)
FIG. 29-2**

USING CART STOPS (IF EQUIPPED) - Continued

WARNING

Pulling the load from vehicle to platform can result in a fall from platform and serious injury. When unloading vehicle, always push the load out on the platform.

- When loading the platform at bed level, make sure cart stops are open (FIG. 30-1). Push load out of the vehicle. Place all loads as close as possible to the edge of the cart stops as shown in FIG. 30-1. If standing on platform with the load, stand in the footprint area shown and comply with the **WARNING** shown above.

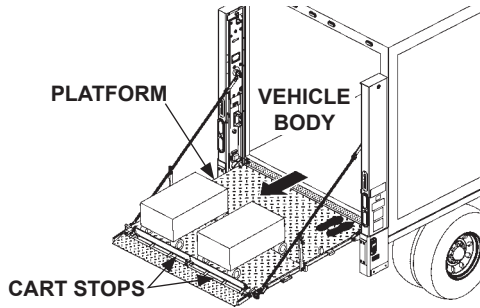

**LOADING PLATFORM AT BED LEVEL
(DUAL CART STOPS OPEN)**
FIG. 30-1

NOTE: Cart stops are kept closed by a cart stop lock (FIG. 30-2).

- Unload platform with cart stops at ground level as follows. Make sure cart stops are closed before moving load off the platform (FIG. 30-2). To close, push the cart stop lock down. Then, step on cart stop until closed (FIG. 30-2). Move load off the platform as shown in FIG. 30-2.

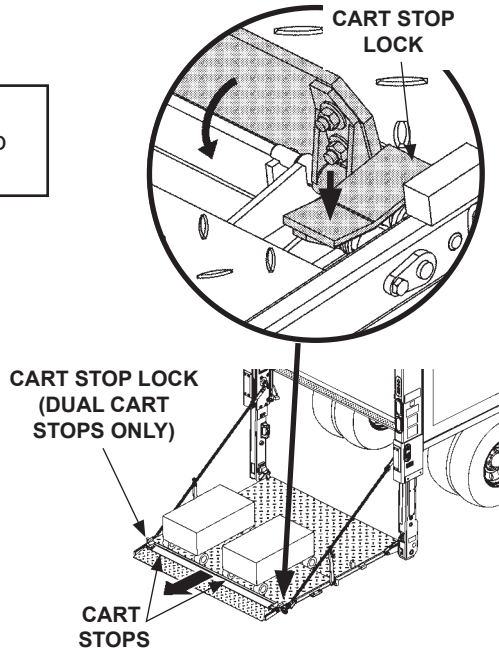

**UNLOADING PLATFORM AT GROUND
(DUAL CART STOPS CLOSED)**
FIG. 30-2

USING AUTO CART STOPS (IF EQUIPPED)

NOTE: Some Liftgates are equipped with auto cart stops. Auto cart stops open and close automatically depending on the position of the liftgate. The following procedure shows auto cart stops.

1. Move load on platform on the ground as shown in **FIG. 31-1**.

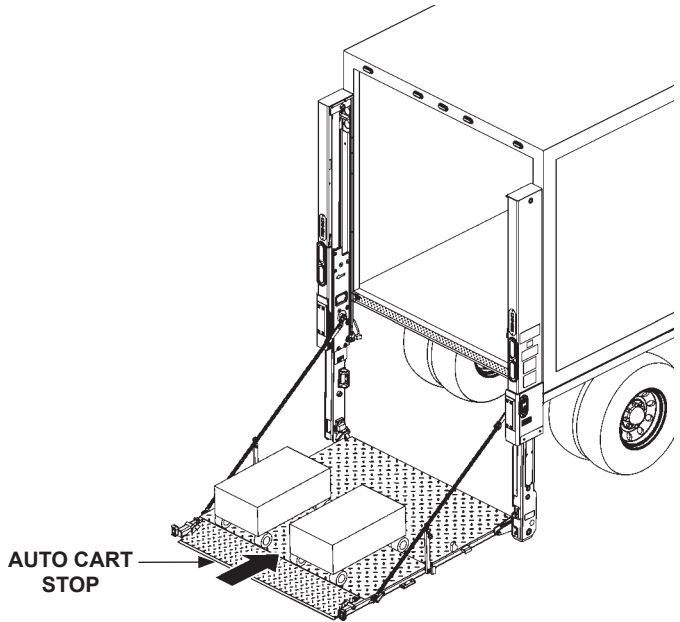

**LOADING PLATFORM AT GROUND LEVEL
(AUTO CART STOP CLOSED)
FIG. 31-1**

USING AUTO CART STOPS (IF EQUIPPED) - Continued

NOTE: Auto cart stop is opened by raising the platform (FIG. 32-1).

- Stand in the footprint area as shown (FIG. 32-1) before raising the platform.

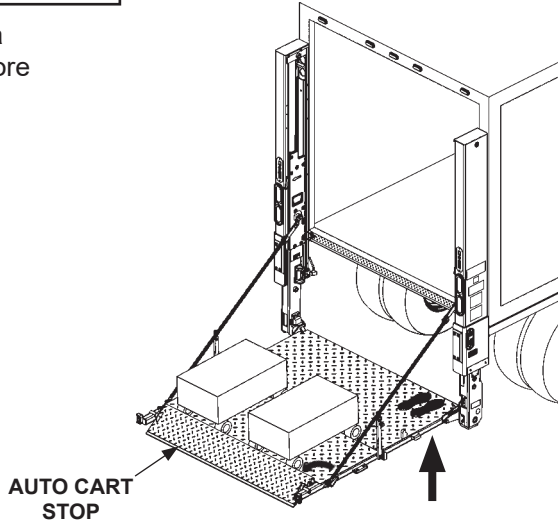

**AUTO CART STOP OPEN
FIG. 32-1**

- Raise the platform to bed level (FIG. 32-2). Move the load off the platform into the vehicle body (FIG. 32-2).

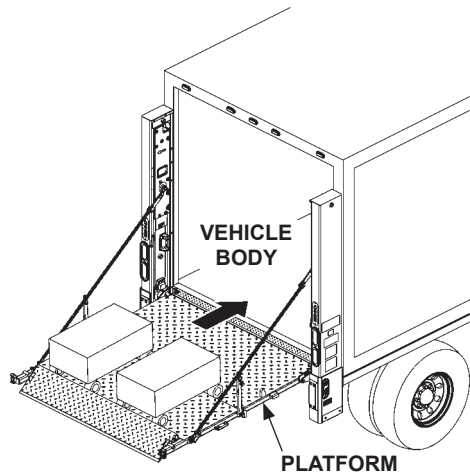

**UNLOADING PLATFORM AT BED LEVEL
(AUTO CART STOP OPEN)
FIG. 32-2**

! WARNING

Pulling the load from vehicle to platform can result in a fall from platform and serious injury. When unloading vehicle, always push the load out on the platform.

NOTE: When loading the platform at bed level, auto cart stop is open (**FIG. 33-1**).

4. Push load out of the vehicle and place all loads as close as possible to the edge of the cart stop(s) as shown in **FIG. 33-1**. If standing on platform with the load, stand in the footprint area shown and comply with the **WARNING** shown above.

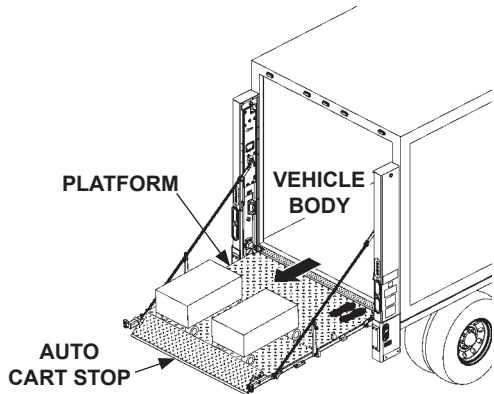

**LOADING PLATFORM AT BED LEVEL
(AUTO CART STOP OPEN)
FIG. 33-1**

NOTE: Auto cart stop is closed when platform is on the ground (**FIG. 33-2**).

5. Unload platform with auto cart stop at ground level as follows. Move load off the platform as shown in **FIG. 33-2**.

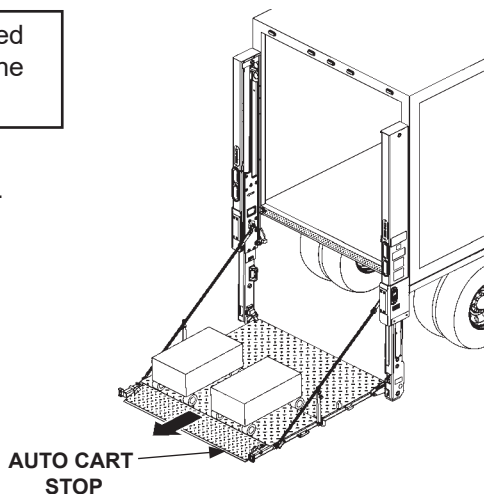

**AUTO CART STOP CLOSED
FIG. 33-2**

DOCK LOADING & UNLOADING LOWER PLATFORM BELOW DOCK LEVEL

CAUTION

Use dock plate for moving loads between dock and vehicle. Dock plate must be supported by dock and vehicle floor. It must not rest on Liftgate platform.

NOTE: Platform may be lowered with vehicle backed up to dock.

1. Use column switch to lower (**DOWN**) platform until it rests on bottom stops (**FIG. 34-1**). Release switch when top edge of closed platform is below bed height and dock level, and in the lower locking position (**FIG. 34-1**). Now, loads can be moved between dock and vehicle without using Liftgate.

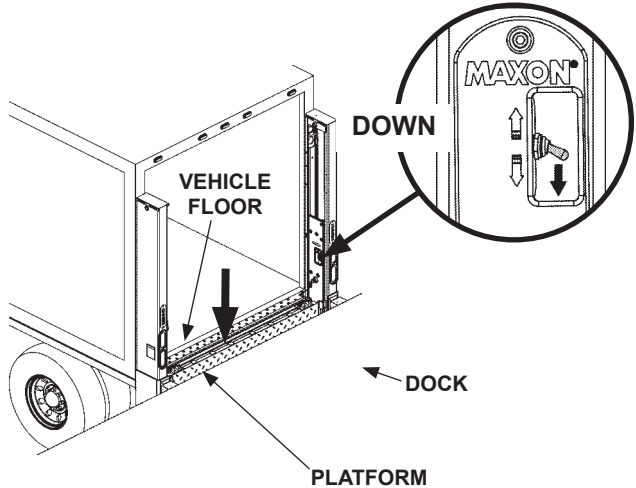

**LOWER LOCKING POSITION
FIG. 34-1**

⚠ WARNING

Upper locking wedges must be engaged before moving vehicle.

2. When finished loading and unloading from the dock, use column switch to raise (UP) platform to upper locking position as follows (FIG. 35-1A). Raise platform until round wedge on each opener arm is behind the upper locking wedge on each column (FIGS. 35-1 & 35-1A).

