

M-18-15  
REV. B  
DECEMBER 2023

# MAXON<sup>®</sup>

## GPTLR Series

### OPERATION MANUAL

GPTLR-25, GPTLR-33, GPTLR-44, & GPTLR-55

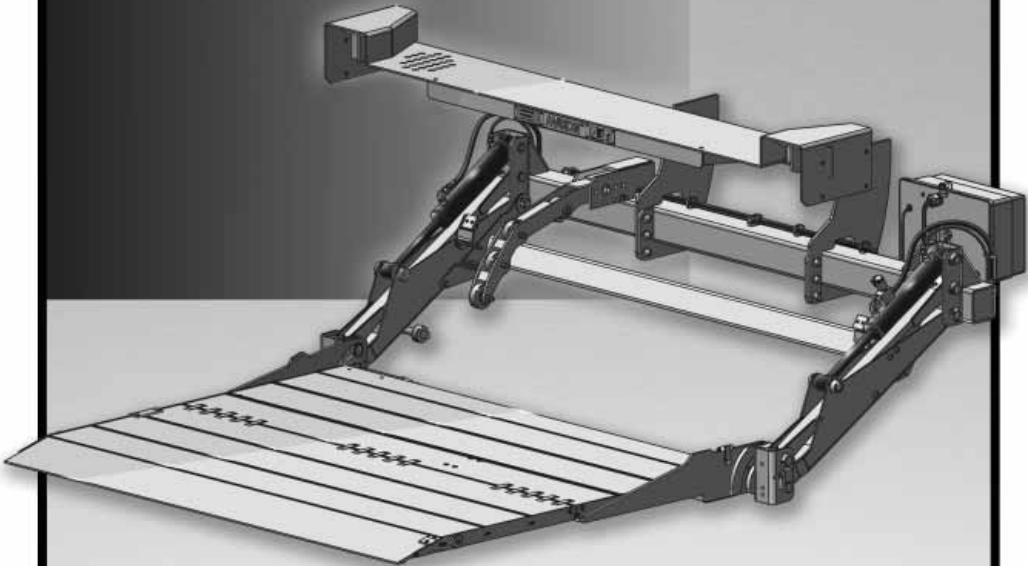

### KEEP THIS MANUAL INSIDE OF VEHICLE

Register your liftgate online at <http://www.maxonlift.com/support/product-registration>. For a free copy of other manuals that pertain to these liftgate models, please visit our website at [www.maxonlift.com](http://www.maxonlift.com) or call Customer Service at (800) 227-4116.

To find **maintenance & parts** information for your **GPTLR Liftgate**, go to [www.maxonlift.com](http://www.maxonlift.com). Click the **PRODUCTS**, **TUK-A-WAY** & **GPTLR** buttons. Open the **Maintenance Manual** in the **PRODUCT DOCUMENTATION** window. For parts, click on the **PARTS PORTAL**, **TUK-A-WAY** & **GPTLR** buttons.



# TABLE OF CONTENTS

<b>SUMMARY OF CHANGES: M-18-15, REVISION B</b> .....	<b>4</b>
<b>WARNINGS</b> .....	<b>5</b>
LIFTGATE TERMINOLOGY .....	6
<b>RECOMMENDED DAILY OPERATION CHECKS</b> .....	<b>7</b>
DECALS .....	9
DECALS & PLATES .....	10
NONSKID & SAFETY STRIPING.....	11
<b>FORKLIFT ADVISORY</b> .....	<b>12</b>
<b>ROADSIDE OPERATION ADVISORY</b> .....	<b>13</b>
<b>OPERATION</b> .....	<b>14</b>
USING STANDARD CART STOPS (IF EQUIPPED) .....	25
USING BACK CART STOPS (IF EQUIPPED) .....	28
USING RETENTION RAMP (IF EQUIPPED).....	32

## SUMMARY OF CHANGES: M-18-15, REVISION B

PAGE	DESCRIPTION OF CHANGE
COVER	Updated cover image, REV. and date of release.
6	Updated Terminology images with callout for ICC bumper and override.
9	Updated Operating Instructions decal P/N 299361-01.
14-23	Added more pages to <b>OPERATION</b> section.
15-16	Paragraph 3 changed to make 2 separate steps to unlatch and unfold the flipover. The paragraphs that follow are renumbered and the layout has more pages.
17	Added step to lower platform to the ground before loading vehicle.
20-23	Added instructions to stow platform if liftgate has a standard extension plate or extension plate with roller. Instructions to unlatch and latch the flipover show a magnified view of the latch.

## **WARNING**

1. Incorrect operation of this Liftgate can result in serious personal injury. Comply with **WARNINGS** and Liftgate operating instructions in this manual. Do not allow untrained persons or children to operate the Liftgate. If you need to replace an **Operation Manual**, additional copies are available from:

**MAXON Lift Corp.**  
**11921 Slauson Ave**  
**Santa Fe Springs, CA 90670**  
**(800) 227-4116**

**NOTE:** For latest version manuals (and replacements), download manuals from Maxon's website at **[www.maxonlift.com](http://www.maxonlift.com)**.

2. Do not exceed rated load capacity of the Liftgates which is **2500 LB for model GPTLR-25, 3300 LB for model GPTLR-33, 4400 LB for model GPTLR-44, and 5500 LB for model GPTLR-55.**
3. Do not allow any part of your body to be placed under, within, or around any portion of the moving Liftgate or its mechanisms, or in a position that would trap them between the platform and the floor of vehicle body (or between platform and the ground) when Liftgate is operating.
4. Consider the safety and location of bystanders and location of nearby objects when operating the Liftgate. Stand to one side of platform while operating the Liftgate. Be certain that the area the Liftgate will move through during operation is clear of all obstacles.
5. Comply with all attached instruction decals and warning decals.
6. Keep decals clean and legible. If decals are illegible or missing, have them replaced. **Get free replacement decals from Maxon.**
7. **Never drive a forklift on the Liftgate platform.**
8. Do not move vehicle unless Liftgate is correctly stowed.
9. **Correctly stow platform when not in use. Extended platforms could create a hazard for people and vehicles passing by.**
10. A correctly installed Liftgate will operate smoothly and reasonably quiet. The only noticeable noise, during Liftgate operation, is from the pump unit while the platform is raised. Listen for scraping, grating and binding noises and have the problem corrected before continuing to operate the Liftgate.
11. Above all, **USE GOOD COMMON SENSE** when operating this Liftgate.
12. Never use a cell phone while operating the Liftgate.

# LIFTGATE TERMINOLOGY

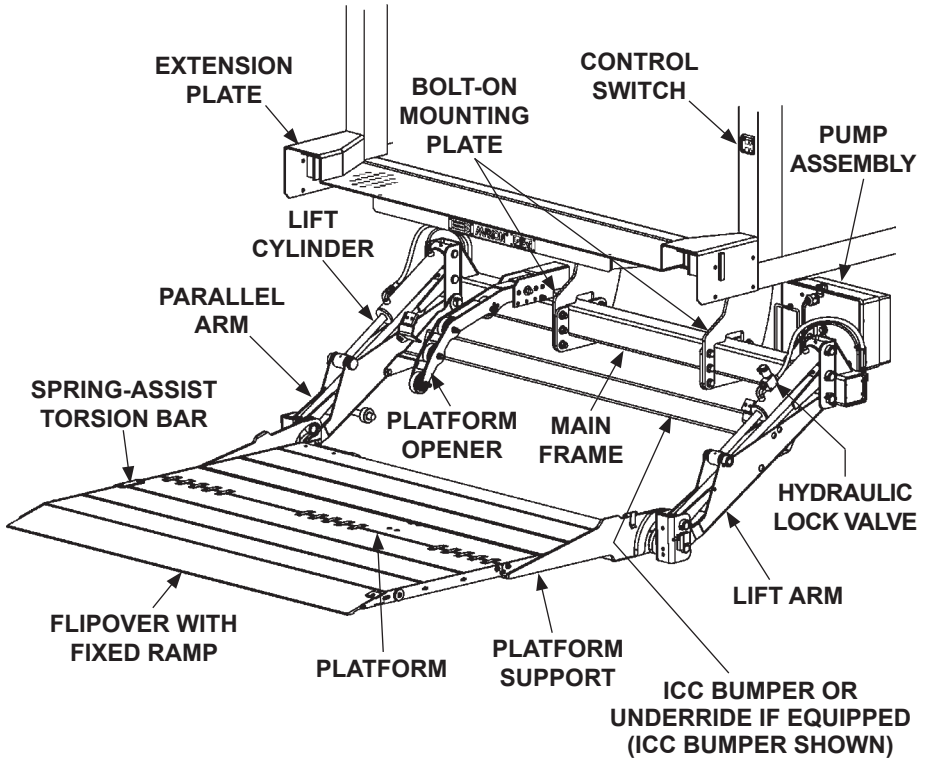

GPTLR LIFTGATE  
FIG. 6-1

# RECOMMENDED DAILY OPERATION CHECKS

**NOTE:** Before you check the Liftgate, park vehicle on flat ground and set the parking brake.

**NOTE:** If any of the following operation checks reveal a need to service or repair Liftgate, do not operate the Liftgate until a qualified mechanic services or repairs the Liftgate.

## **Before operating the Liftgate, the operator should do the following:**

- Make sure battery is fully charged and battery terminal connections are clean and tight.
- Make sure cab cutoff switch is **ON**, if equipped.
- Visually check that pump cover is bolted on securely and undamaged. Look for hydraulic fluid leaking from the pump box.
- Visually check that control switch is in place and undamaged.
- Visually check for cracks and bends on the extension plate. Also, make sure fasteners are in place and undamaged and extension plate is clean (no oil, debris, or corrosion).
- Visually check that all decals, nonskid stickers, and safety striping are in place (see **DECALS and NONSKID & SAFETY STRIPING** pages). Also, make sure decals are legible and decals, nonskid, and safety striping are clean and undamaged.

## **Use the operation instructions in this manual to lower the Liftgate to the ground and open the platform and flipover.**

- Check main frame, lift arms, parallel arms and platform openers for cracks and bends. Make sure rollers, on the platform openers, roll freely. Also, make sure all bolts and pins are in place and undamaged.
- Make sure main frame, lift arms, parallel arms and platform openers are clean (no oil, debris, or corrosion).
- Check the hydraulic cylinders for leaking seals and hose connections. Follow the hydraulic hoses (or return lines for gravity down Liftgates) from the cylinders to pump box. Make sure all hoses are connected at both ends and there are no cracks, chafing, and fluid leaks.
- Ensure up-stop bumpers under the extension plate are in place and undamaged.

**NOTE:** Liftgates may be equipped with a retention ramp. Since the tip of the flipover for the retention ramp is different from the standard flipover, a 2" distance between tip and ground is acceptable (see YES illustrations).

- With the platform unfolded and on the ground, check if the shackles and the tip of platform touch the ground at the same time (**YES illustration**). If the platform looks like the **YES illustration**, you can operate Liftgate. If the shackles are off the ground and platform looks like the **NO illustration**, do not operate the Liftgate. (See **NOTE** at beginning of the **DAILY OPERATION CHECKS**.)

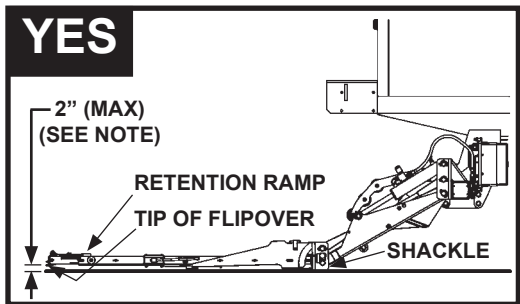
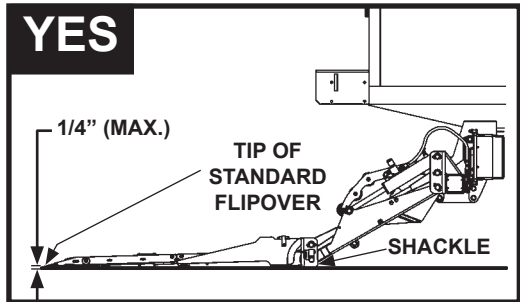

- Check the platform and flipover for cracks, holes, and bends on the load-carrying surface and side plates. Also, make sure torsion bars, coil springs, and fasteners are in place and undamaged.

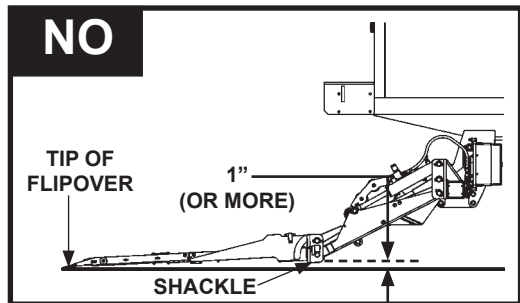

- Make sure platform and flipover load-carrying surfaces are clean (no oil, debris, or corrosion).

**Use the operation instructions in this manual to operate the Liftgate through one cycle without a load on the platform. RAISE the platform to vehicle bed height. Then, lower the platform to ground level.**

- When the Liftgate is moving, listen for unusual noises and look for jerking motion or uneven movement on either side of the platform.

**If service or repairs are not required (or if completed), stow the Liftgate.**



# DECALS

**NOTE:** Decals for street side are included with an optional street side control switch kit.

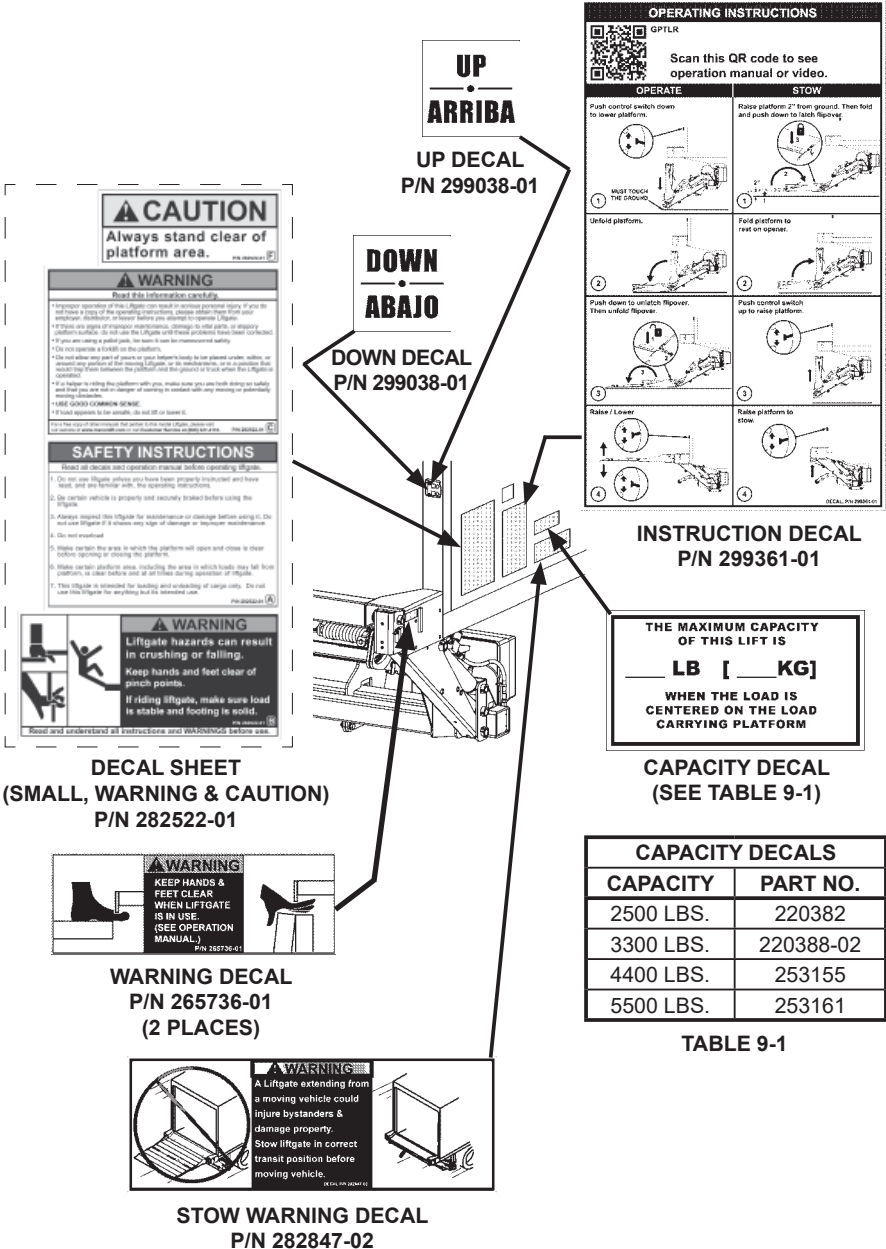
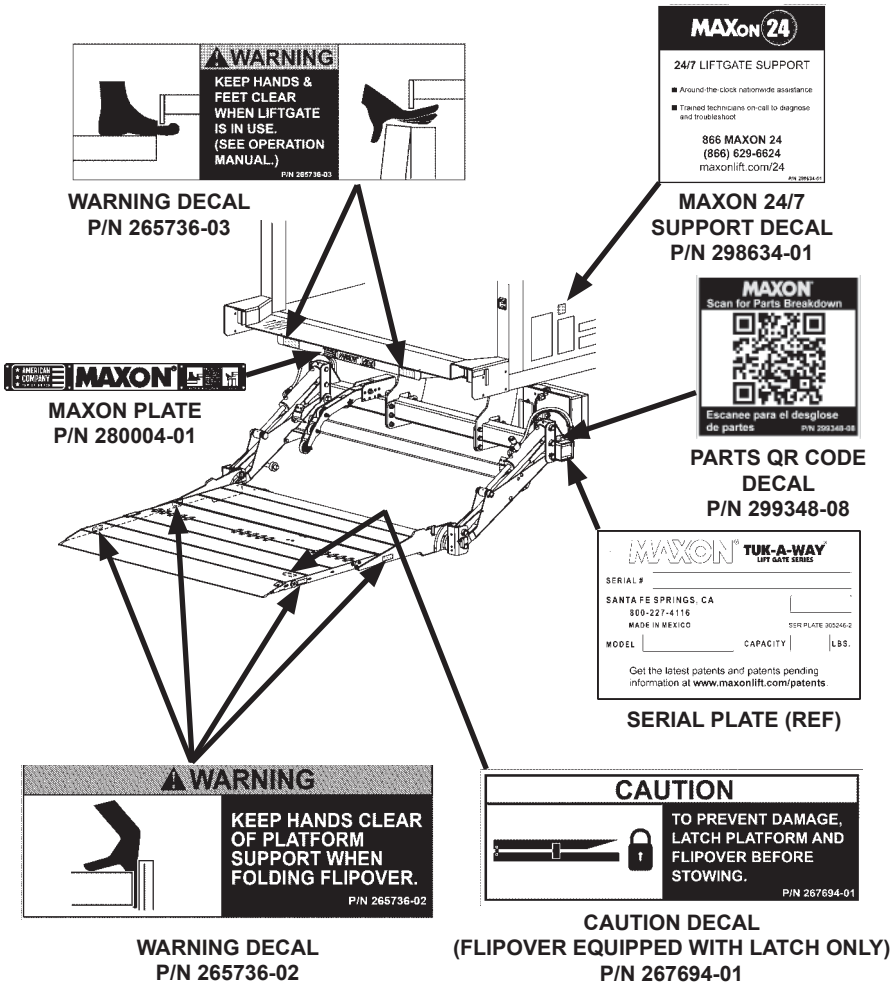

FIG. 9-1

# DECALS & PLATES



**NOTE: MAXON 24/7 LIFTGATE SUPPORT service is only available in the U.S.**

**FIG. 10-1**

# NONSKID & SAFETY STRIPING

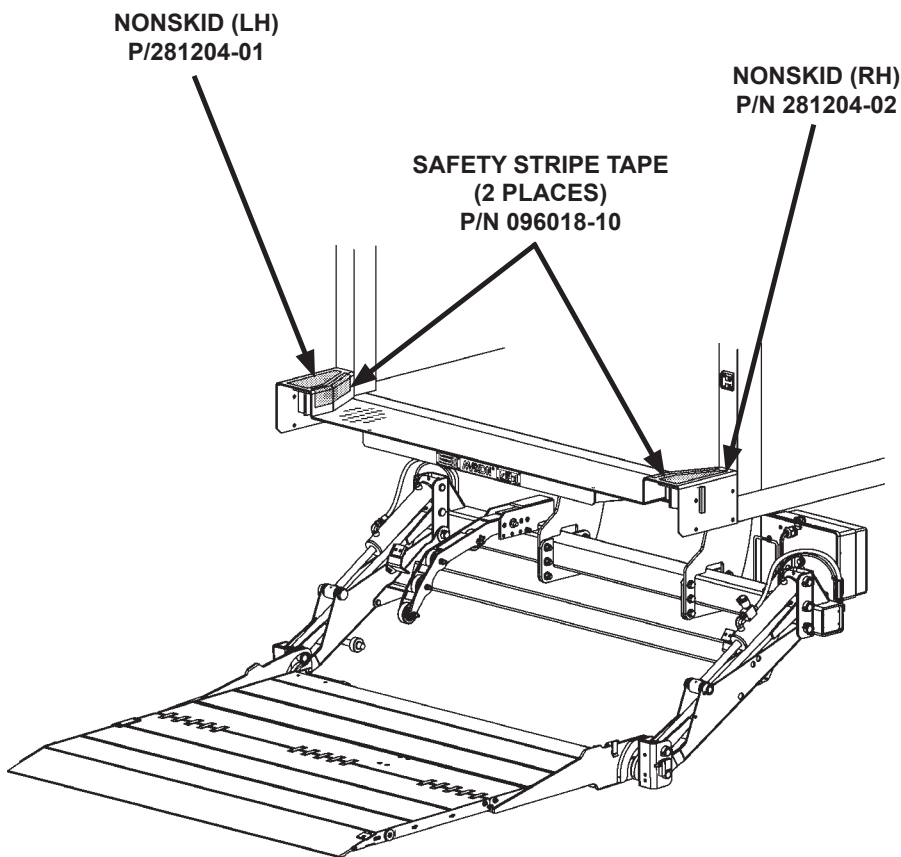

FIG. 11-1

# FORKLIFT ADVISORY



**WARNING**

**Keep forklift OFF of platform.**

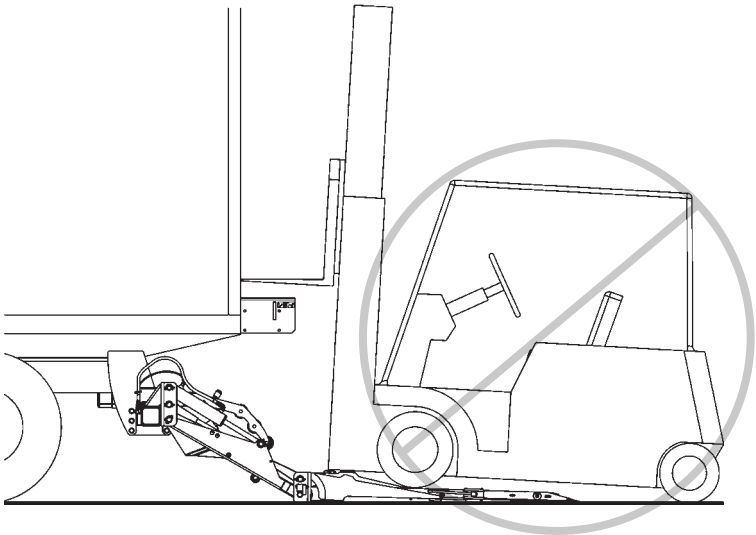
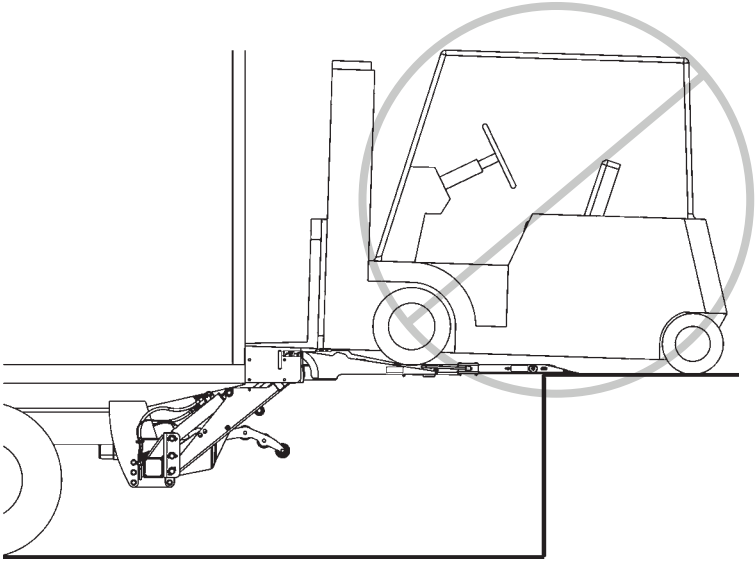

**FIG. 12-1**

# ROADSIDE OPERATION ADVISORY

## **WARNING**

Operating the Liftgate by the side of a busy road with vehicle traffic increases the chance of personal injury and damage to Liftgate, cargo & vehicle. Making the loading area more visible to passing traffic can help reduce the chance of injury and damage.

**NOTE:** MAXON recommends placing at least 2 traffic cones on the traffic side of the platform loading area as illustrated below. Remove cones after platform is stowed and before moving the vehicle.

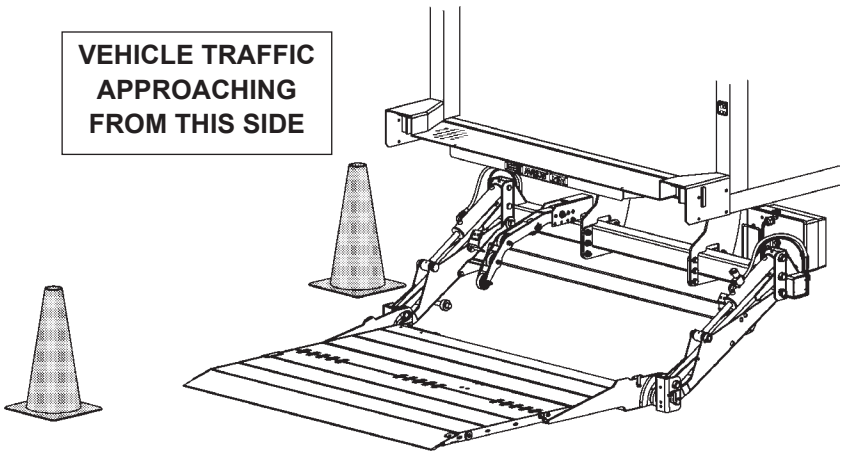

**TRAFFIC CONES POSITIONED BY PLATFORM LOADING AREA**  
**FIG. 13-1**

## OPERATION

1. Standing to the side of platform (**FIG. 14-1**), push the toggle switch **DOWN** as shown in **FIG. 14-1A**. Lower the platform until it touches the ground.

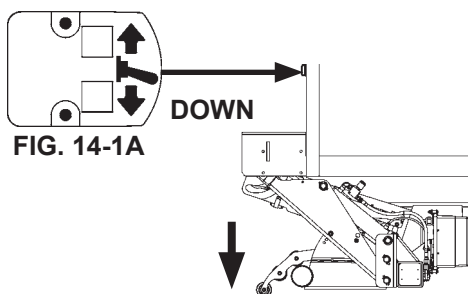

**FIG. 14-1A**

**LOWERING PLATFORM-**  
**FIG. 14-1**



### **WARNING**

**Never operate control switch while unfolding platform.**

2. Unfold platform (**FIG. 14-2**).

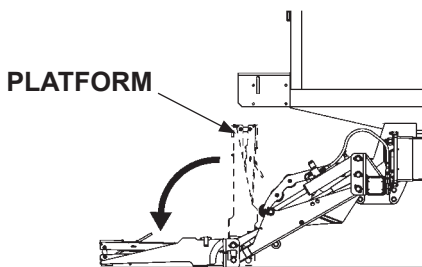

**UNFOLDING PLATFORM**  
**FIG. 14-2**

**⚠ WARNING**

**To prevent injury, pull the latch only as shown.**

**NOTE:** Flipover must be unlatched before it can be unfolded.

3. Unlatch the flipover as follows.  
First push down on the flipover.  
Then, pull the latch to release  
(FIG. 15-1).

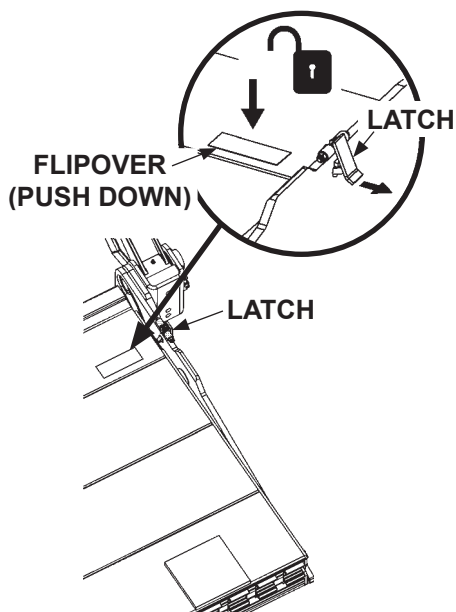

**UNLATCHING FOLDED FLIPOVER  
(RH SIDE OF ALUMINUM  
FLIPOVER SHOWN)  
FIG. 15-1**

## OPERATION - Continued

4. Unfold the flipover (FIG. 16-1).

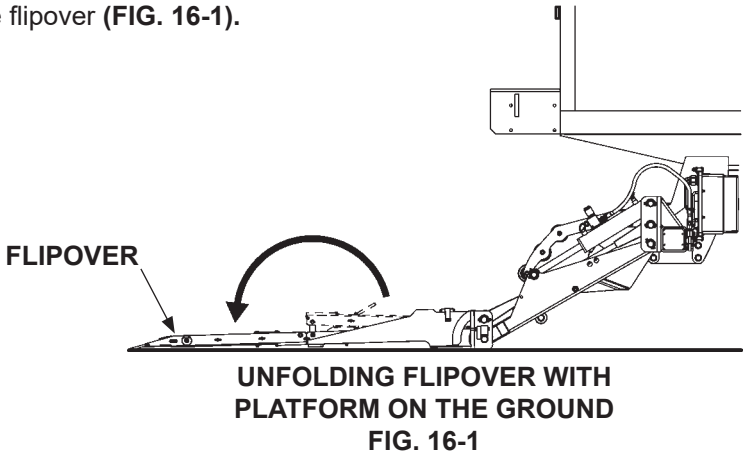

**NOTE:** While operating Liftgate, release toggle switch to stop platform.

5. Raise the platform (FIG. 16-2) by pushing the toggle switch to the **UP** position (FIG. 16-2A). Wait a second after platform reaches bed height before releasing the toggle switch. To lower the platform, push the toggle switch **DOWN** (FIG. 16-2B).

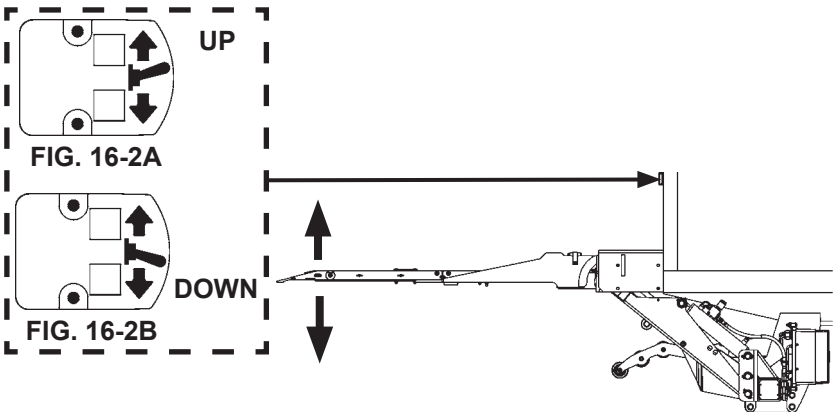



6. To load platform on the ground, stand to the side of platform (**FIG. 17-1**) and push the toggle switch **DOWN** (**FIG. 17-1A**). Lower platform until it touches the ground.

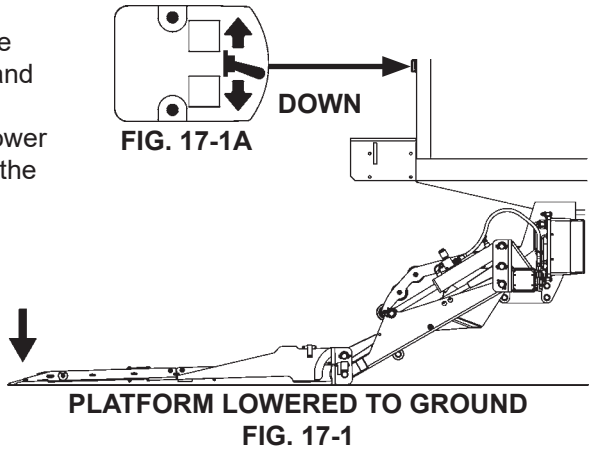

## OPERATION - Continued

### **⚠ WARNING**

A load should never extend past the edges of the platform. Do not place unstable loads on platform and do not allow load to exceed the lifting capacity of the Liftgate. If standing on platform, do not allow your feet to extend beyond the inboard edge of the platform.

7. Move load on the platform at ground level, as shown in FIG. 18-1.

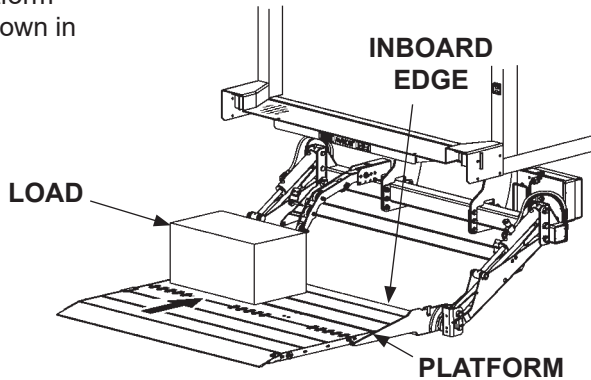

**LOADING PLATFORM AT GROUND LEVEL  
FIG. 18-1**

8. Raise the platform to bed level (FIG. 18-2). Move load from platform to inside the vehicle body.

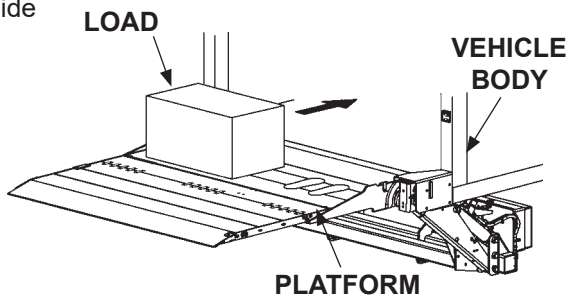

**UNLOADING PLATFORM AT BED LEVEL  
FIG. 18-2**

**⚠ WARNING**

**Pulling the load from vehicle to platform can result in a fall from platform and serious injury. When unloading vehicle, always push the load out on the platform.**

9. Load the platform at bed level as follows. Push load out of the vehicle to correct position on the platform (**FIG. 19-1**). Place all loads as close as possible to the inboard edge of the platform with heaviest part toward the vehicle body as shown in **FIG. 19-1**. If standing on platform with the load, stand in the footprint area shown and comply with the **WARNING** on page 18.

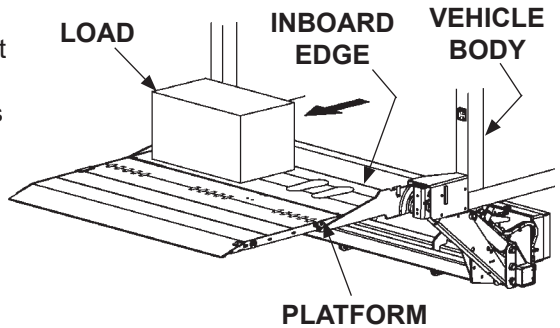

**LOADING PLATFORM AT BED LEVEL  
FIG. 19-1**

10. Lower the platform to ground level (**FIG. 19-2**). Then, move load off the platform.

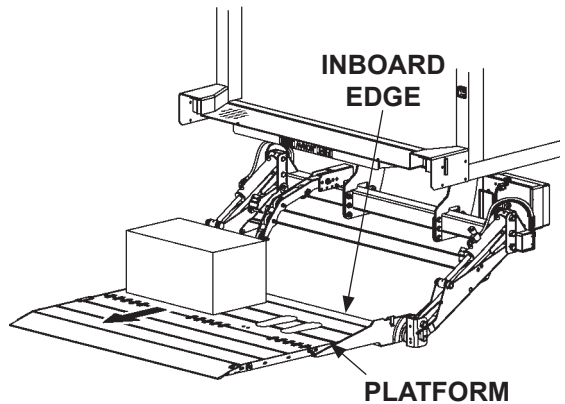

**UNLOADING PLATFORM AT GROUND LEVEL  
FIG. 19-2**

# OPERATION - Continued

## ⚠ WARNING

**Never move the vehicle unless the Liftgate is properly stowed.**

**NOTE:** Use the following instructions to prepare platform to stow. Most extension plates do not have a roller for stowing the platform. However, a special extension plate may be equipped with a roller to stow the platform.

11. Before moving the vehicle, prepare the Liftgate as follows. Make sure load is removed from platform. If the platform is at bed height, push the toggle switch **DOWN** (FIG.20-1A). Release toggle switch when platform is on the ground (FIG. 20-1).

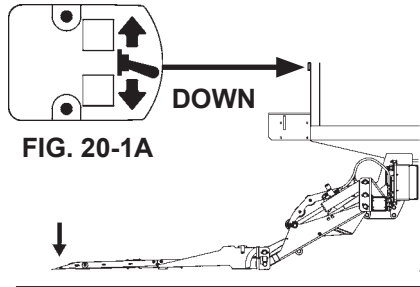

FIG. 20-1A

LOWERING PLATFORM  
FIG. 20-1

**NOTE:** Platform raised off the ground makes it easier to grasp and fold the flip-over. If extension plate is equipped with roller, it also allows folded platform and flipover to rest on roller.

12. Push toggle switch **UP** (FIG. 20-2A) to raise platform 2" above the ground (FIG. 20-2). If extension plate is equipped with a roller, (FIG. 20-3) raise platform high enough to allow platform and flipover to fold against roller.

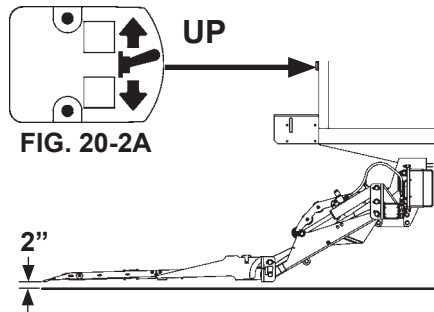
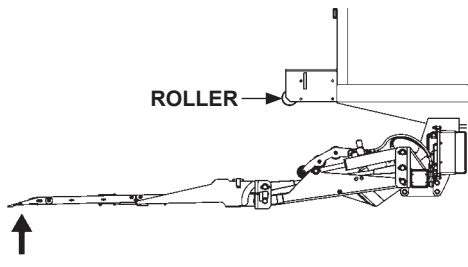

FIG. 20-2A

PLATFORM RAISED TO STOW WITH  
STANDARD EXTENSION PLATE  
FIG. 20-2



PLATFORM RAISED TO STOW WITH  
EXTENSION PLATE ROLLER  
FIG. 20-3

**⚠ WARNING**

**Keep hands clear of the platform support when folding the flipover.**

**NOTE:** Before folding flipover, make sure cart stops or retention ramp (if equipped) are stowed.

13. Fold the flipover on platform  
(FIGS. 21-1 or 21-2).

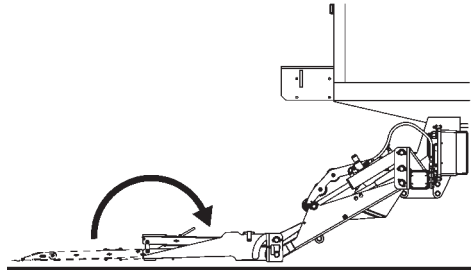

**FOLDING FLIPIVER  
FIG. 21-1**

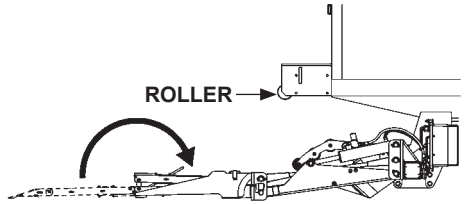

**FOLDING FLIPIVER  
(EXTENSION PLATE WITH ROLLER)  
FIG. 21-2**

## OPERATION - Continued

**NOTE:** When flipover is folded, make sure it is latched securely.

15. Push down on flipover so it is latched securely to platform support (FIG. 22-1).

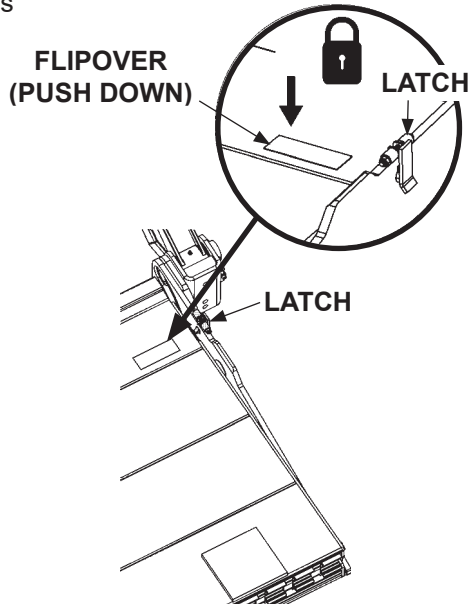

**FLIPOVER FOLDED & LATCHED  
(RH SIDE OF ALUMINUM FLIPOVER SHOWN)  
FIG. 22-1**

### **⚠ WARNING**

**Keep hands clear of the extension plate when folding platform on the roller and/or opener.**

16. For Liftgate equipped with standard extension plate, fold platform on opener (FIG. 22-1). Then, skip step 17. If extension plate is equipped with a roller (FIG. 23-1), do step 17.

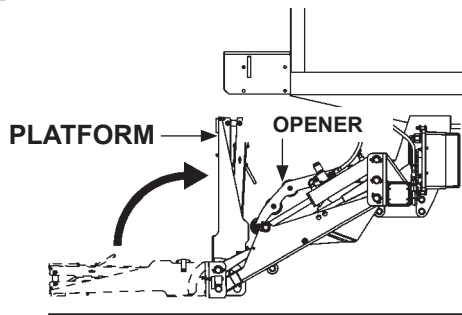

**FOLDING PLATFORM ON OPENER  
FIG. 22-1**

17. Fold platform against roller on extension plate (**FIG. 23-1**). Then, push the toggle switch **DOWN** (**FIG. 23-2A**) to lower the platform on the opener (**FIG. 23-2**).

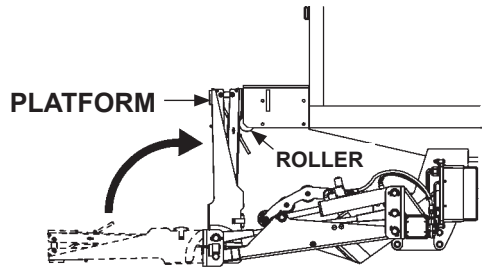

---

**PLATFORM FOLDED AGAINST ROLLER**  
**FIG. 23-1**

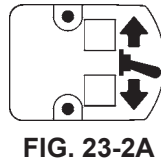

**FIG. 23-2A**

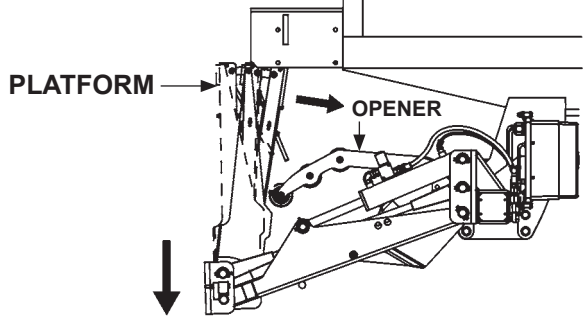

---

**PLATFORM FOLDED ON OPENER**  
**FIG. 23-2**

## OPERATION - Continued

### CAUTION

**Stow Liftgate under hydraulic pressure.**

18. Raise the platform to stowed position by pushing the toggle switch **UP** (FIG. 24-1A). Wait a second after platform is raised all the way (FIG. 24-1). Then release toggle switch.

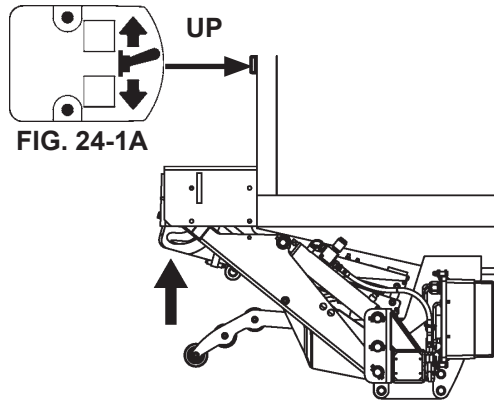

**CORRECTLY STOWED LIFTGATE**  
**FIG. 24-1**

19. Liftgate is ready for transport.



# USING STANDARD CART STOPS (IF EQUIPPED)

## CAUTION

To prevent injuries caused by tripping and falling, make sure cart stops are closed before walking on and off outboard end of platform.

**NOTE:** Some Liftgates are equipped with single or dual cart stops. Cart stops prevent loaded carts from rolling off outboard end of platform. Single cart stops are 1 section, about the same as overall width of platform, and operate with one set of controls. Dual cart stops are 2 identical sections, with a combined width about the same as overall width of platform, and each is independently operated with separate controls (1 set of controls per cart stop). The following procedure shows how to operate dual cart stops; however, a single cart stop operates the same way.

1. Load a platform with cart stops at ground level as follows. Make sure cart stops are closed when loading the platform (**FIGS. 25-1 and 25-2**). Then, move load on the platform as shown in **FIG. 25-1**.

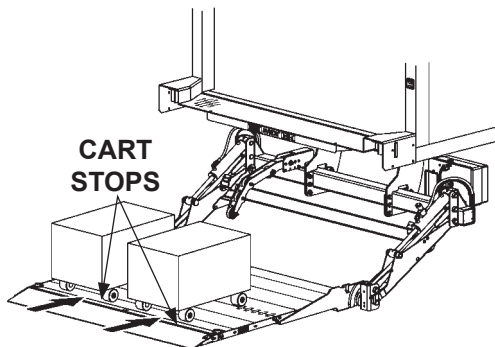

**LOADING PLATFORM AT GROUND LEVEL  
(CART STOPS CLOSED)  
FIG. 25-1**

2. To close cart stops, push on the opener block as shown in **FIG. 25-2**.

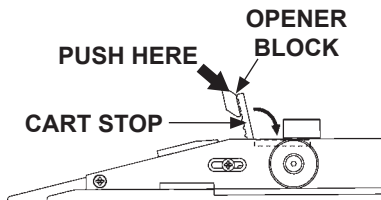

**CLOSING CART STOPS  
(RH VIEW OF FLIPOVER)  
FIG. 25-2**

# USING STANDARD CART STOPS (IF EQUIPPED) - Continued

3. To open cart stops, push on the opener block as shown in FIG. 26-1.

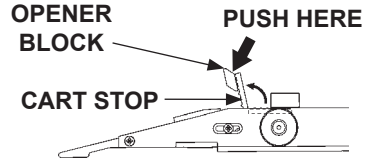

**OPENING CART STOPS  
(RH VIEW OF FLIP OVER)  
FIG. 26-1**

4. Open cart stops (FIGS. 26-1 and 26-2). Next, position cart and stand in the footprint area as shown in FIG. 26-2.

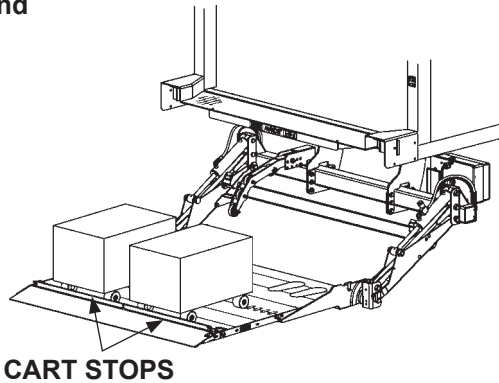

**CART STOPS OPEN  
FIG. 26-2**

5. Raise the platform to bed level (FIG. 26-3). Move the load off the platform into the vehicle body (FIG. 26-3).

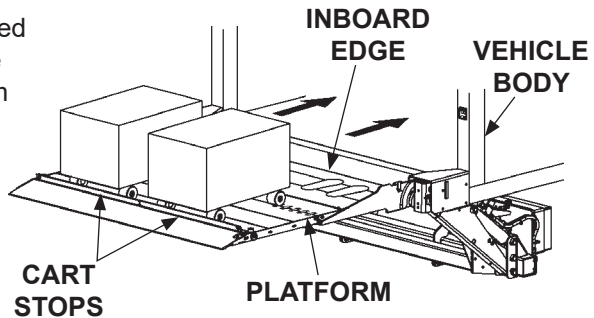

**UNLOADING PLATFORM AT BED LEVEL  
FIG. 26-3**

## **⚠ WARNING**

**Pulling the load from vehicle to platform can result in a fall from platform and serious injury. When unloading vehicle, always push the load out on the platform.**

6. When loading the platform at bed level, make sure cart stops are open (FIG. 27-1). Push load out of the vehicle to correct position on the platform. Place all loads as close as possible to the inboard edge of the platform with heaviest part toward the vehicle body as shown in FIG. 27-1. If standing on platform with the load, stand in the footprint area shown and comply with the **WARNING** on page 18.

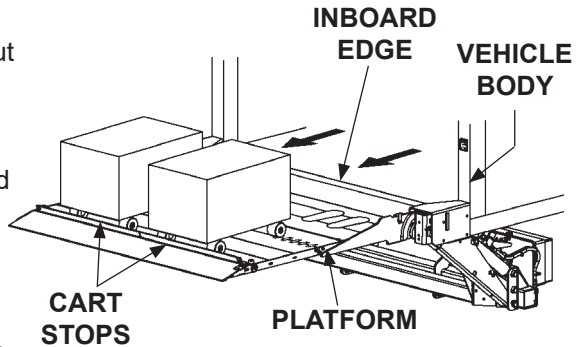

**LOADING PLATFORM AT BED LEVEL  
(CART STOP OPEN)  
FIG. 27-1**

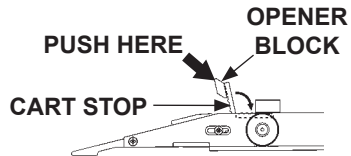

**CLOSING CART STOPS  
(RH VIEW OF FLIPOVER)  
FIG. 27-2**

7. Unload the platform with cart stops at ground level as follows. Make sure cart stops are closed (FIG. 27-2) when unloading the platform (FIG. 27-3). Move cart enough to close cart stop. Then, move load off the platform as shown in FIG. 27-3.

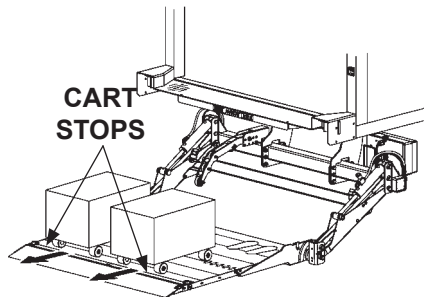

**CART STOPS CLOSED  
FIG. 27-3**

## USING BACK CART STOPS (IF EQUIPPED)

### CAUTION

To prevent injuries caused by tripping and falling, make sure cart stops are latched closed when not in use.

**NOTE:** Cart stops prevent loaded carts from rolling off the platform. The following procedure shows how to operate back cart stops.

1. With the platform at ground level, open the back cart stop(s) by stepping on the cart stop with one foot and sliding foot over the latch in the direction shown in FIG. 28-1.

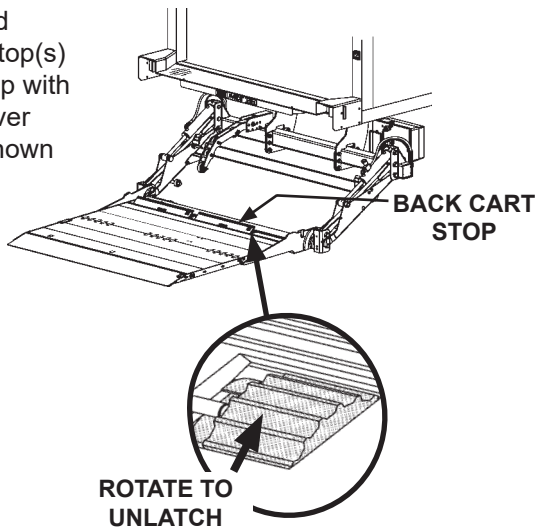

**OPENING BACK CART STOPS  
(PLATFORM AT GROUND LEVEL)  
FIG. 28-1**

**NOTE:** As the cart rolls inside vehicle body, the front wheels of the cart will close the cart stop. Cart stop will reopen when the cart wheels roll off.

**NOTE:** Load should be as close as possible to the inboard edge of the platform with heaviest part toward the vehicle body.

2. Move the cart(s) onto the platform as shown in **FIG. 29-1**. Position cart wheels against open cart stops. If standing on platform with the load, stand in the footprint area shown in **FIG. 29-1**.

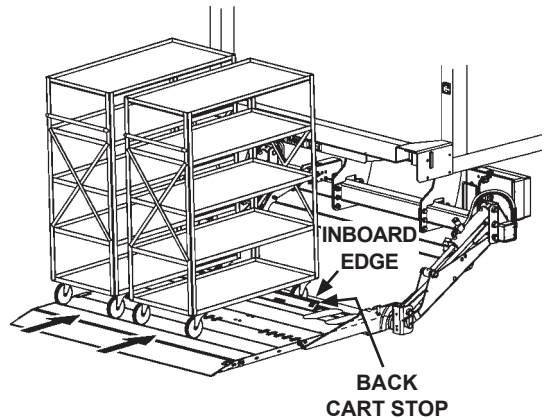

**LOADING PLATFORM AT GROUND LEVEL  
FIG. 29-1**

3. Raise the platform to bed level and move the cart(s) into the vehicle body. Refer to **FIG. 29-2**.

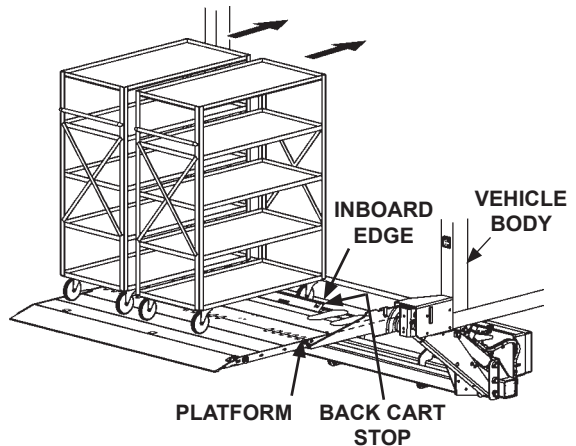

**UNLOADING PLATFORM AT BED LEVEL  
FIG. 29-2**

## USING BACK CART STOPS (IF EQUIPPED) - Continued

### **WARNING**

Pulling the load from vehicle to platform can result in a fall from platform and serious injury. When unloading vehicle, always push the load out on the platform.

**NOTE:** As the cart rolls inside vehicle body, the rear wheels of the cart will close the cart stop.

**NOTE:** Load should be as close as possible to the inboard edge of the platform with heaviest part toward the truck body.

4. Close the cart stop by stepping on it. Then, roll the front wheels of the cart over the cart stop. Step off to let the cart stop open. Push cart(s) out of the vehicle until rear wheels are positioned against the cart stop as shown in **FIG. 30-1**. If standing on platform with the load, stand in the footprint area shown and comply with the **WARNING** on page 18.

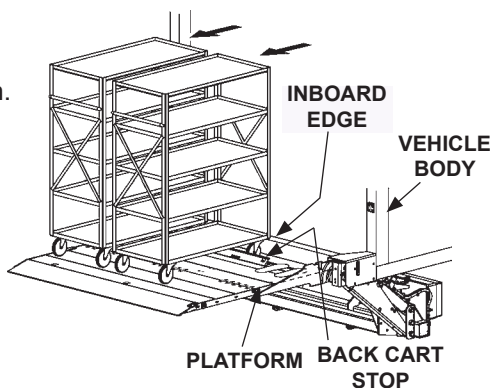

**LOADING PLATFORM AT BED LEVEL  
(BACK CART STOP OPEN)  
FIG. 30-1**

5. Move cart(s) off the platform at ground level as follows. Move cart enough to close cart stop. Step on the cart stop until wheels have passed. Then, move cart(s) off the platform as shown in FIG. 31-1.

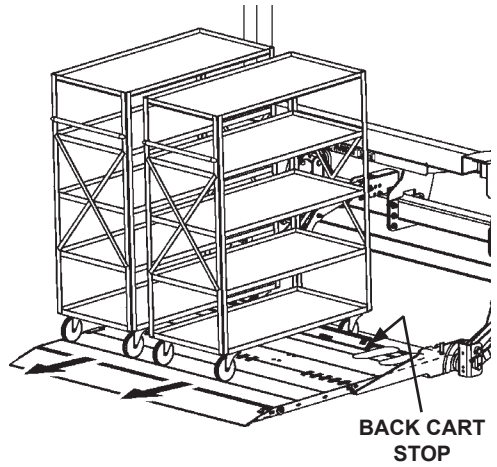

**MOVING CARTS OFF PLATFORM**  
**FIG. 31-1**

6. With the platform at ground level, close the back cart stop(s) by stepping on the cart stop with one foot and sliding foot over the latch in the direction indicated by FIG. 31-2.

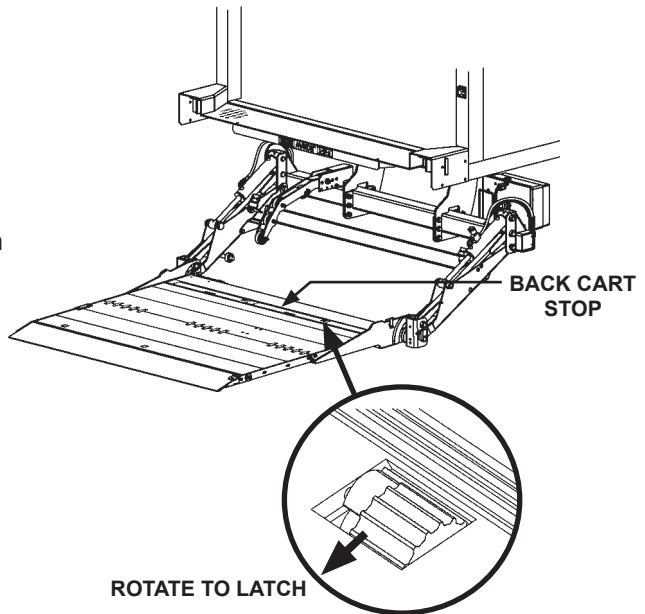

**CLOSING CART STOPS**  
**FIG. 31-2**

## USING RETENTION RAMP (IF EQUIPPED)

### CAUTION

To prevent injuries caused by tripping and falling, make sure retention ramp is in the ramp position before walking on and off outboard end of platform.

**NOTE:** Some Liftgates are equipped with a retention ramp. A retention ramp, like a cart stop, prevents loaded carts from rolling off outboard end of platform. Unlike a cart stop, a retention ramp lets you use the entire load surface of the platform. The catches on top of the flipover and a cam-like hinge action keep retention ramp stowed when not in use. The cam-like hinge also allows the retention ramp to be rotated and locked in retention position or in ramp position. The following procedure shows how to operate a retention ramp.

1. Load the platform with retention ramp at ground level as follows. Make sure retention ramp is in the ramp position when loading the platform (**FIG. 32-1**). Next, move load on the platform as shown in (**FIG. 32-1**). Then do the steps that follow to place the retention ramp in the retention position.

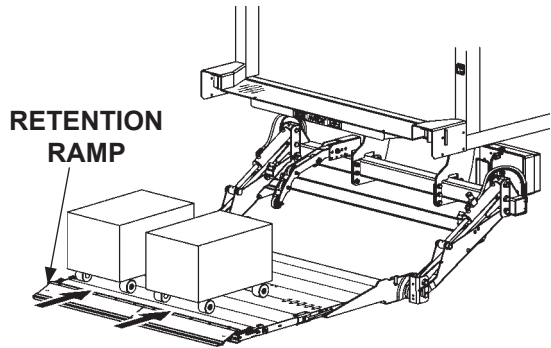

**LOADING PLATFORM AT GROUND LEVEL  
(SHOWN IN RAMP POSITION)**

**FIG. 32-1**



**NOTE:** To unhook the retention ramp, stand at the RH side of flipover. After the retention ramp is unhooked, the recommended place for handling the retention ramp is at the center of the free edge (**FIG. 33-2**).

2. Unhook retention ramp (**FIG. 33-1**). To release from the catches, pull retention ramp toward outboard end of flipover as shown in **FIG. 33-2**.

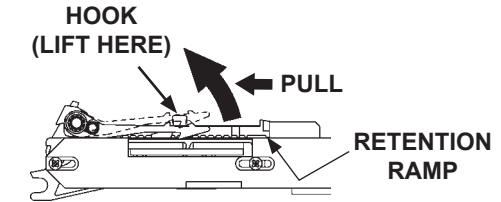

**UNHOOKING RETENTION RAMP  
(RH VIEW OF FLIPOVER)  
FIG. 33-1**

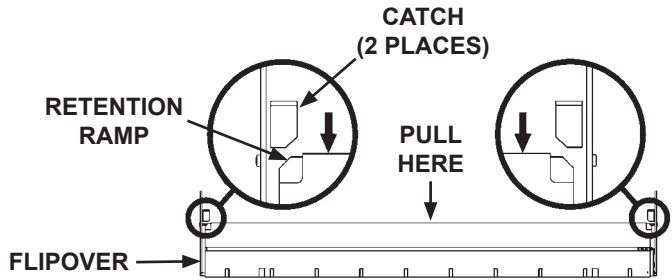

**RELEASING RETENTION RAMP  
(TOP VIEW OF FLIPOVER)  
FIG. 33-2**

# USING RETENTION RAMP (IF EQUIPPED) - Continued

## **! CAUTION**

To prevent injuries, stay clear of the retention ramp path as it is moved to ramp position. Go to either side of the ramp and stay out of the way.

3. Continue to pull retention ramp to the retention position (FIG. 34-1) and then to ramp position (FIG. 34-2).

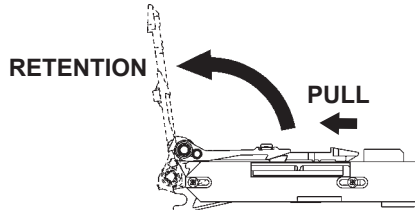

**MOVING TO RETENTION POSITION  
(RH VIEW OF FLIP OVER)  
FIG. 34-1**

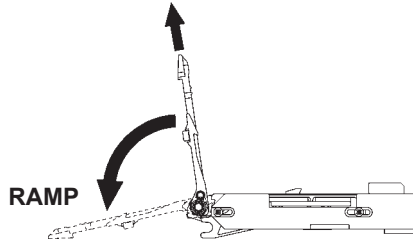

**MOVING TO RAMP POSITION  
(RH VIEW OF FLIP OVER)  
FIG. 34-2**

4. When cart is on platform, place the retention ramp in the retention position (FIGS. 34-3 and 34-4). Next, stand in the footprint area shown in FIG. 34-3.

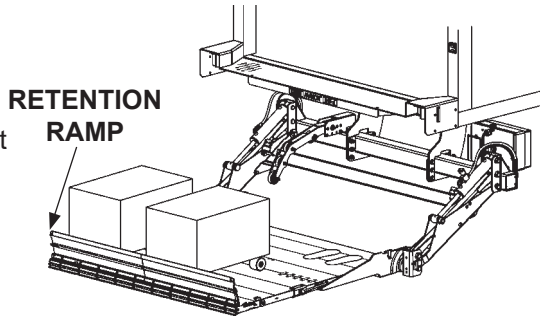

**RAMP IN RETENTION POSITION  
FIG. 34-3**

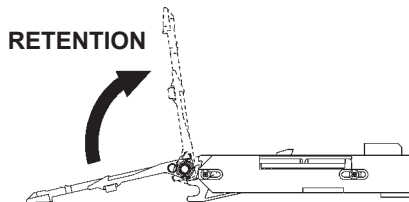

**ROTATING TO RETENTION POSITION  
(RH VIEW OF FLIP OVER)  
FIG. 34-4**

5. Raise the platform to bed level (FIG. 35-1). Move the load off the platform into the vehicle body (FIG. 35-1).

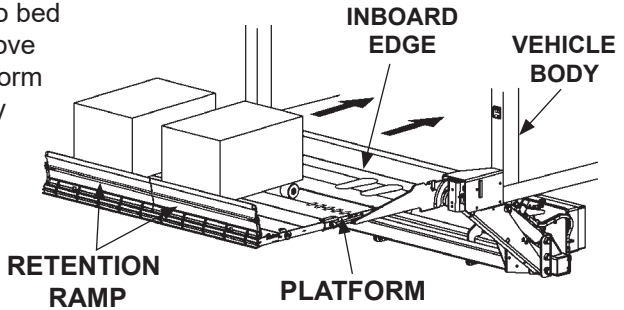

UNLOADING PLATFORM AT BED LEVEL  
FIG. 35-1

**! WARNING**

Pulling the load from vehicle to platform can result in a fall from platform and serious injury. When unloading vehicle, always push the load out on the platform.

6. When loading the platform at bed level, make sure retention ramp is in the retention position (FIG. 33-2). Push load out of the vehicle to correct position on the platform. Place all loads as close as possible to the inboard edge of the platform with heaviest part toward the vehicle body as shown in FIG. 35-2. If standing on platform with the load, stand in the footprint area shown and comply with the **WARNING** on page 18.

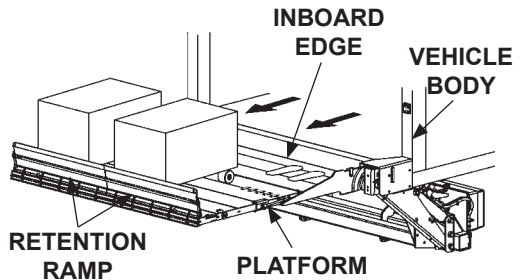

LOADING PLATFORM AT BED LEVEL  
(RAMP IN RETENTION POSITION)  
FIG. 35-2

# USING RETENTION RAMP (IF EQUIPPED) - Continued

7. Unload the platform with retention ramp at ground level as follows. Make sure retention ramp is in the ramp position when unloading the platform (**FIG. 36-1**). Move cart enough to reposition retention ramp. Then, move load off the platform as shown in **FIG. 36-2**.

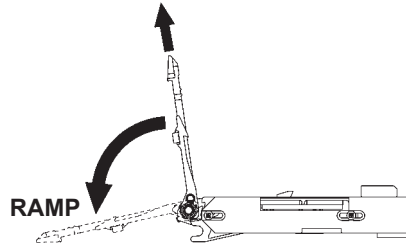

**ROTATING TO RAMP POSITION  
(RH VIEW OF FLIPOVER)  
FIG. 36-1**

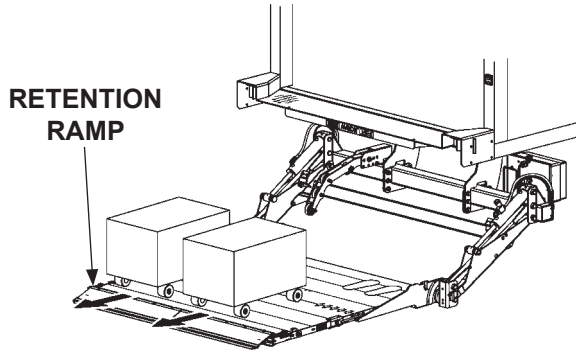

**UNLOADING PLATFORM AT  
GROUND LEVEL (RAMP POSITION)  
FIG. 36-2**

8. To stow, rotate retention ramp to retention position and then to the flat position on flipover as shown in **FIG. 36-3**.

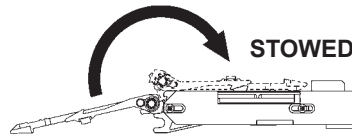

**ROTATING RAMP TO STOWED  
POSITION (RH VIEW OF FLIPOVER)  
FIG. 36-3**

9. Push the retention ramp fully into the catches (FIG. 37-1).

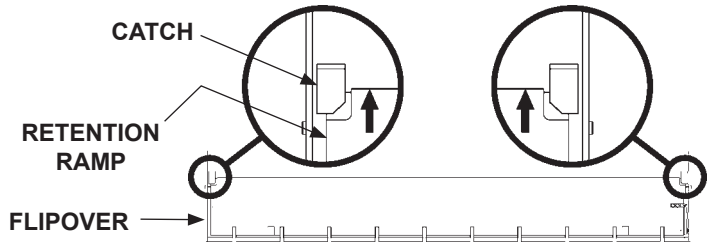

**STOWING THE RAMP  
(TOP VIEW OF FLIPOVER)  
FIG. 37-1**

10. Make sure retention ramp is hooked to the flipover (FIG. 37-2).

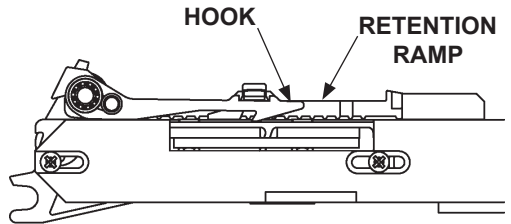

**RAMP HOOKED TO FLIPOVER  
(RH VIEW OF FLIPOVER)  
FIG. 37-2**

