

# SLIDELIFT® SERIES

## The GPSLRT Series

# MAXON®

New in 2024



## GPSLRT SPECIFICATIONS

**Level ride, up to 5,500 lbs. lifting capacity, and the industry's toughest finish create the smartest choice in sliders for trucks.**

- Level-ride platform
- Aluminum flip-over sections with MAX GRIP® surface treatment
- SmartSpace (gap between platform and rear sill)
- Hydraulic locking system
- Flashing platform lights standard
- **Galvanized Finish-STANDARD!**

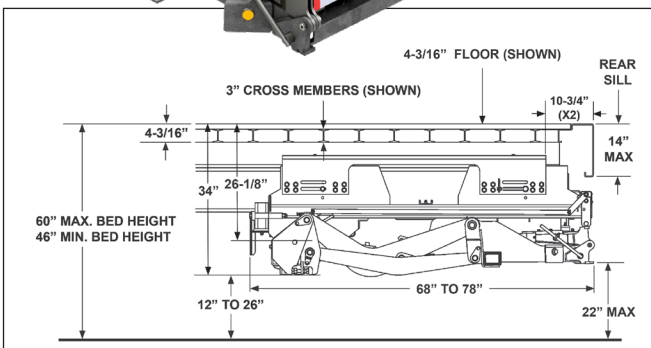

Clearances For GPSLRT With 68" To 78" Slide Rails (Truck)

NOTE: Please review appropriate liftgate installation manual for full vehicle and or body requirements to ensure proper fitment.

MODEL CAPACITY	PLATFORM SIZE	TOTAL WEIGHT	BED HEIGHT
GPSLRT35 (3,500 lbs)	86" X 51"+9" Fixed Ramp Optional Dual Cart Stops	1,690 Lbs.	46" Min. with Body Laden 60" Max. with Body Unladen
	86" X 60"+12" Single or Dual retention ramp		
GPSLRT44 (4,400 lbs)	86" X 63"+9" Fixed Ramp Optional Dual Cart Stops	1,815 Lbs.	
	86" X 72"+12" Single or Dual retention ramp		
GPSLRT55 (5,500 lbs)	86" X 80"+12" Single or Dual retention ramp	1,950 Lbs.	



# SLIDELIFT® SERIES

## The GPSLRT Series

# MAXON®

### Standard Features

- Galvanized Standard
- MAX GRIP® Platform Treatment
- Cycle Counter
- SmartSpace
- Level Ride Platform
- Hydraulic Locking System
- Lightweight AL Flip-Over

### Optional Features

- Dual Cart Stops
- Hand-held Control
- Power Down
- Dual Power Units
- Dual Pump & Motor
- MAX ECU
- Platform Railing Kit

### Loadable Platform Space with Cart Stops Deployed

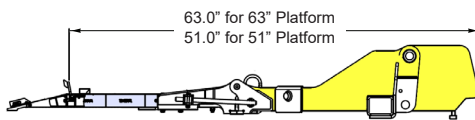

### Level Ride

The GPSLRT rides level all the way to the ground, similar to a rail liftgate. The platform design allows for loads to be easily loaded on and off because it sits completely flat on the ground.



### Aluminum Platform, Flip-Over MAX GRIP®

The platform flip-over features dual assist torsion springs that minimize the opening and closing force. Flip-over surface is cross-hatched for improved slip resistance (MAX GRIP®)

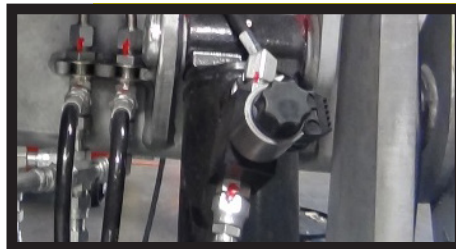

### Hydraulic Locking System

The GPSLRT features a hydraulic locking system that takes the operator out of the equation. The hydraulic system automatically locks when the gate is in the stow position requiring no additional operator effort.



### Lift Arm Design

The GPSLRT features a stress-optimized lift arm design that yields two key benefits: First, the stout and solid design provides ample support even when loaded to its rated capacity! Secondly, the design allows to bridge up to 13" rear seal depth without notching.



### Fully Galvanized - STANDARD

Galvanization is the process by which zinc is coated over corrosive (easily rusted) metals. The process of galvanizing not only protects from corrosion of various 'soft metals' but also adds strength to the original, uncoated metal

Distributed by:

M-284-0424



Maxon Lift Corp. 11921 Slauson Ave., Santa Fe Springs, CA 90670  
800.227.4116 Fax 888.771.7713, www.maxonlift.com