

MAXON[®]

M-18-12
REV B
MAY 2023

RA Series

OPERATION MANUAL

RA-35 & RA-45

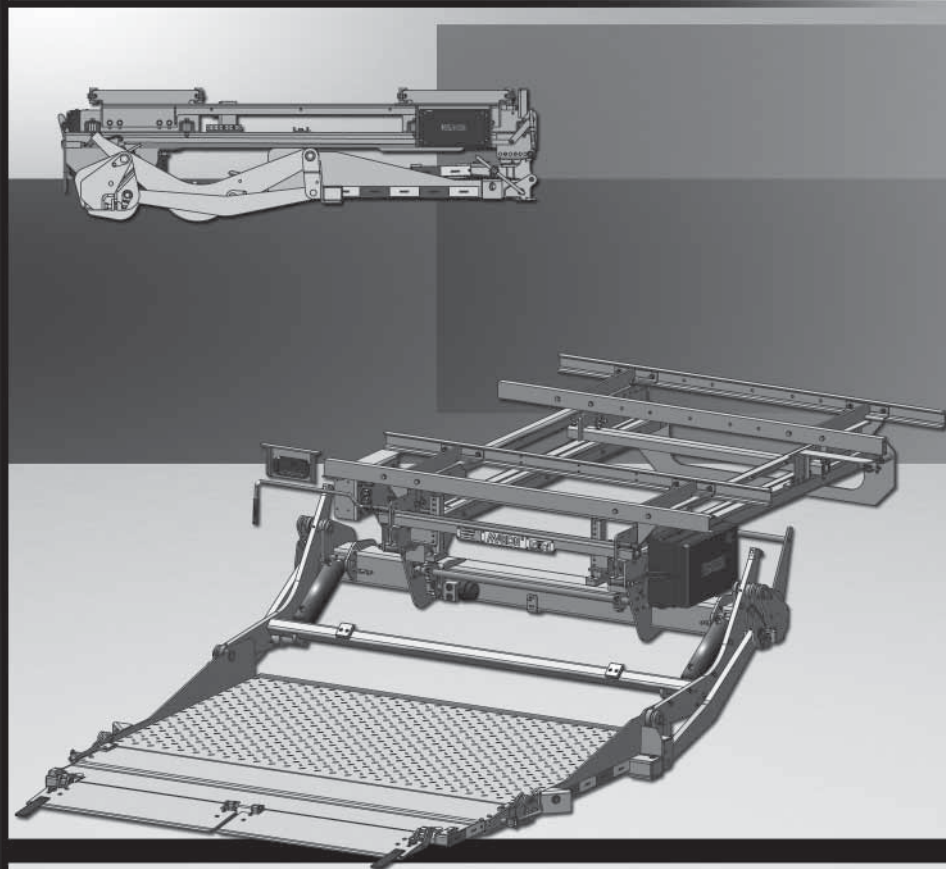

© MAXON Lift Corp. 2023

KEEP THIS MANUAL IN CAB OF VEHICLE

TABLE OF CONTENTS

SUMMARY OF CHANGES: M-18-12, REVISION B.....	4
WARNINGS.....	5
LIFTGATE TERMINOLOGY	7
RECOMMENDED DAILY OPERATION CHECKS.....	8
DECALS	10
FORKLIFT ADVISORY	14
OPERATION.....	15

SUMMARY OF CHANGES: M-18-12, REVISION B

PAGE	DESCRIPTION OF CHANGE
COVER	Updated REV. and date of release. Updated RA-44 model to RA-45.
	Illustrations changed to new design.
10	Updated capacity decal to 4500 LB (P/N 220388-05) and Operation Decal to P/N 283024-03.

WARNING

1. Incorrect operation of this Liftgate can result in serious personal injury. Comply with **WARNINGS** and Liftgate operating instructions in this manual. Do not allow untrained persons or children to operate the Liftgate. If you need to replace an **Operation Manual**, additional copies are available from:

**MAXON Lift Corp.
11921 Slauson Ave
Santa Fe Springs, CA 90670
(800) 227-4116**

NOTE: For latest version manuals (and replacements), download manuals from Maxon's website at **www.maxonlift.com**.

2. Do not exceed rated load capacity of the Liftgate, which is **3500 lb for the RA-35 and 4500 lb for the RA-45**.
3. Do not allow any part of your body to be placed under, within, or around any portion of the moving Liftgate or its mechanisms, or in a position that would trap them between the platform and the floor of truck body (or between platform and the ground) when Liftgate is operating.
4. Consider the safety and location of bystanders and location of nearby objects when operating the Liftgate. Stand to one side of platform while operating the Liftgate. Be certain that the area the Liftgate will move through during operation is clear of all obstacles.
5. Comply with all attached instruction decals and warning decals.
6. Keep decals clean and legible. If decals are illegible or missing, have them replaced. **Get free replacement decals from Maxon.**
7. **Never drive a forklift on the Liftgate platform.**
8. Do not move vehicle unless Liftgate is correctly stowed.
9. **Correctly stow platform when not in use. Extended platforms could create a hazard for people and vehicles passing by.**
10. A correctly installed Liftgate will operate smoothly and reasonably quiet. The only noticeable noise, during Liftgate operation, is from the power unit while the platform is raised. Listen for scraping, grating and binding noises and have the problem corrected before continuing to operate the Liftgate.
11. Above all, **USE GOOD COMMON SENSE** when operating the Liftgate.
12. Never use a cell phone while operating the Liftgate.

THIS PAGE INTENTIONALLY LEFT BLANK

LIFTGATE TERMINOLOGY

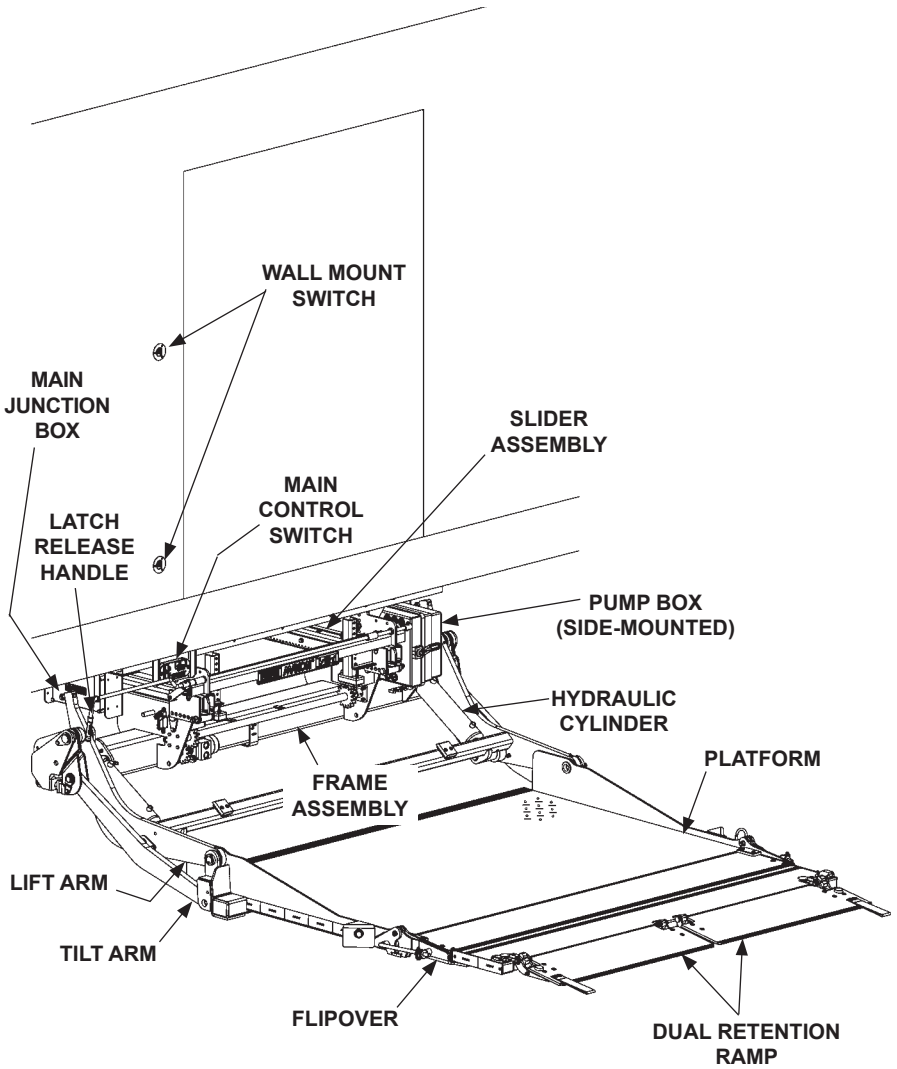

RECOMMENDED DAILY OPERATION CHECKS

NOTE: Before you check the Liftgate, park vehicle on flat ground and set the parking brake.

NOTE: If any of the following operation checks reveal a need to service or repair Liftgate, do not operate the Liftgate until a qualified mechanic services or repairs the Liftgate.

Before operating the Liftgate, the operator should do the following:

- Make sure battery is fully charged and battery terminal connections are clean and tight.
- Make sure cab cutoff switch is **ON**, if equipped, before operating Liftgate.
- Visually check that pump cover is latched closed securely and undamaged. Look for hydraulic fluid leaking from the pump box.
- Visually check that the in-out and up-down control switches are in place and undamaged.
- Visually check that hydraulic locks are in place and undamaged.
- Visually check that all decals and reflective tape are in place (see **DECAL** pages). Also make sure decals and reflective tape are clean, legible, and undamaged.

Use the operation instructions in this manual to run the Liftgate out to operating position, lower platform to the ground, and open flipover or flip ramp (if equipped). Open retention ramp if equipped.

- Check slider assembly, frame assembly, lift arms, and parallel arms for cracks and bends. Also, make sure all bolts, nuts and pins are in place and undamaged.
- Make sure slider assembly, frame assembly, lift arms, and parallel arms are clean (no oil, debris, or corrosion).
- Check the hydraulic cylinders for leaking seals and hose connections. Follow the hydraulic hoses (or return lines for gravity down Liftgates) from the cylinders to pump box. Make sure all hoses are connected at both ends and there are no cracks, chafing, and fluid leaks.

- With the flipover (or flip ramp) unfolded and platform raised to bed level, check if the platform is level (**YES illustration**). If the platform looks like the **YES illustration**, you can operate Liftgate. If the top surface of platform is above or below level line like the **NO illustrations**, do not operate the Liftgate. (See **NOTE** at beginning of the **DAILY OPERATION CHECKS**.)

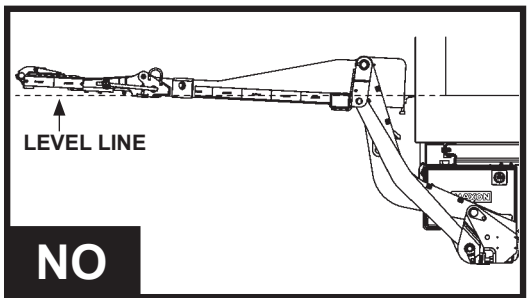
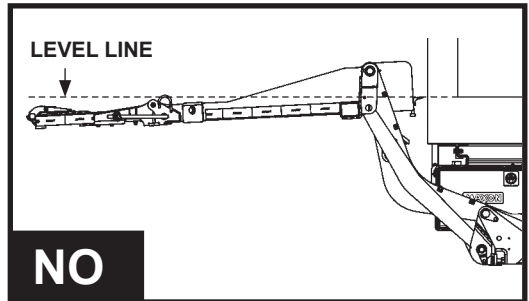
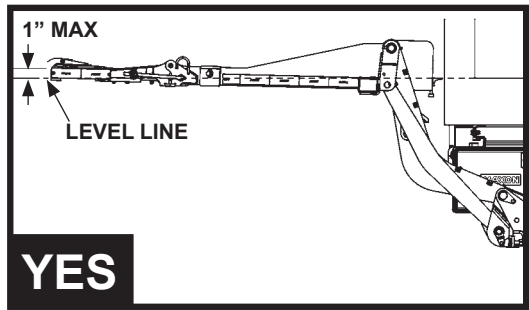

- Check the platform, flipover (or flip ramp) for cracks, holes, and bends on the load-carrying surface and side plates. If equipped, check retention ramp for cracks, holes, and bends. Also, make sure torsion bars and fasteners are in place and undamaged.
- Make sure platform and flipover load-carrying surfaces are clean (no oil, debris, or corrosion).

Use the operation instructions in this manual to operate the Liftgate through one cycle without a load on the platform. Raise the platform to vehicle bed height. Next, lower the platform to ground level.

- When the Liftgate is moving, listen for unusual noises and look for a “jerking” motion or uneven movement on either side of the platform.

If service or repairs are not required (or if completed), stow the Liftgate according to operating instructions in this manual.

DECALS



**CAUTION DECAL
P/N 282682-05**

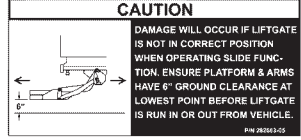

**CAUTION DECAL
P/N 282683-05**

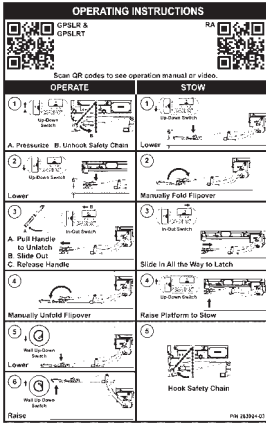

**OPERATION DECAL
P/N 283024-03**

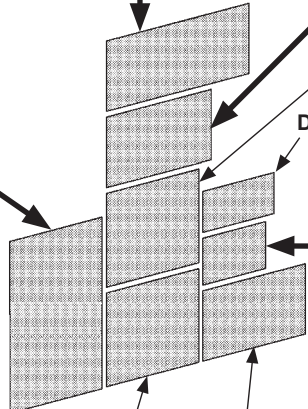

DECAL "C"

DECAL "B"

DECAL "A"

DECAL "F"

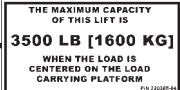

**CAPACITY DECAL
(RA-35 ONLY)
P/N 220388-04**

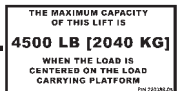

**CAPACITY DECAL
(RA-45 ONLY)
P/N 220388-05**

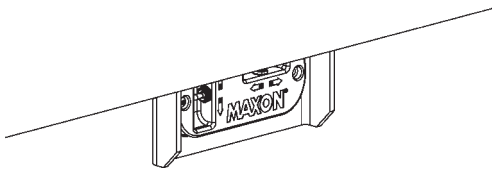

FIG. 10-1

▲ CAUTION
Always stand clear of platform area. P/N 282522-01 (F)

▲ WARNING
Read this information carefully.

- Improper operation of this Liftgate can result in serious personal injury. If you do not have a copy of the operating instructions, please obtain them from your employer, distributor, or lessor before you attempt to operate Liftgate.
- If there are signs of improper maintenance, damage to vital parts, or slippery platform surface, do not use the Liftgate until these problems have been corrected.
- If you are using a pallet jack, be sure it can be maneuvered safely.
- Do not operate a forklift on the platform.
- Do not allow any part of yours or your helper's body to be placed under, within, or around any portion of the moving Liftgate, or its mechanisms, or in a position that would trap them between the platform and the ground or truck when the Liftgate is operated.
- If a helper is riding the platform with you, make sure you are both doing so safely and that you are not in danger of coming in contact with any moving or potentially moving obstacles.
- **USE GOOD COMMON SENSE**
- If load appears to be unsafe, do not lift or lower it

For a free copy of other manuals that pertain to this model Liftgate, please visit our website at www.maxonlift.com or call Customer Service at (800) 227-4116. P/N 282522-01 (C)

SAFETY INSTRUCTIONS
Read all decals and operation manual before operating liftgate.

1. Do not use liftgate unless you have been properly instructed and have read, and are familiar with, the operating instructions.
2. Be certain vehicle is properly and securely braked before using the liftgate.
3. Always inspect this liftgate for maintenance or damage before using it. Do not use liftgate if it shows any sign of damage or improper maintenance.
4. Do not overload
5. Make certain the area in which the platform will open and close is clear before opening or closing the platform.
6. Make certain platform area, including the area in which loads may fall from platform, is clear before and at all times during operation of liftgate.
7. This liftgate is intended for loading and unloading of cargo only. Do not use this liftgate for anything but its intended use.

P/N 282522-01 (A)

▲ WARNING
Liftgate hazards can result in crushing or falling.
Keep hands and feet clear of pinch points.
If riding liftgate, make sure load is stable and footing is solid. P/N 282522-01 (B)

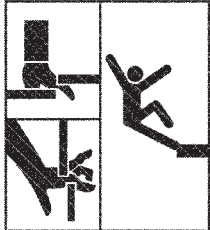

Read and understand all instructions and WARNINGS before use.

DECAL SHEET
P/N 282522-01
FIG. 11-1

DECALS - Continued



MAXON PLATE
P/N 280004-01

WARNING
Incorrect use of battery power could result in personal injury and equipment damage. Never use the power terminals in this junction box to jump liftgate batteries that are in a low state of charge. Charge liftgate batteries directly at the battery terminals.
P/N 283023-01

BATTERY WARNING DECAL
P/N 283023-01



SERIAL PLATE (REF)



QR PARTS DECAL
P/N 299349-03

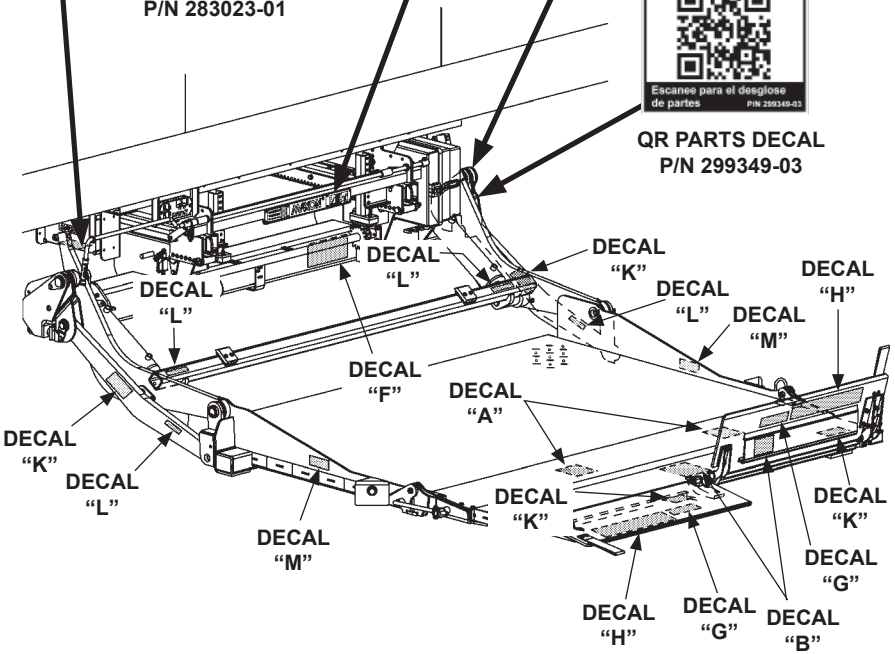

FIG. 12-1

▲ WARNING



When unstowing & stowing platform, stay clear of bumpers. **(A)**

▲ WARNING



To avoid injury stay out of the path where the platform unfolds. Unfold platform from the side. **(B)**

▲ WARNING



Keep hands clear of pinch points when folding flipover. **(M)**

▲ WARNING

To prevent personal injury & equipment damage, avoid working under the platform while platform is raised off the ground. Refer to Maintenance Manual for additional safety instructions. **(F)**

▲ WARNING



To avoid possible injury and damage to equipment, never stand on lift arms, parallel arms, or bottom side of platform. **(K)**

▲ WARNING

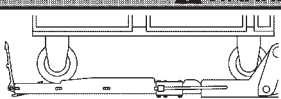

To prevent personal injury & damaged equipment, ramp must be in retention position when cart is being raised or lowered on platform. **(G)**

1 Push locking arm and pull strap to unlock ramp

2 Push locking arm and pull ramp

3 Push locking arm and pull ramp

4 Push ramp

5 Push ramp **(H)**



Locking Arm, Strap, Ramp, Retention Position, Ramp Position

▲ WARNING



Keep hands & feet clear of lifting arms. **(L)**



DECAL SHEET
P/N 267432-03
FIG. 13-1

FORKLIFT ADVISORY

⚠ WARNING

Keep forklift OFF of platform.

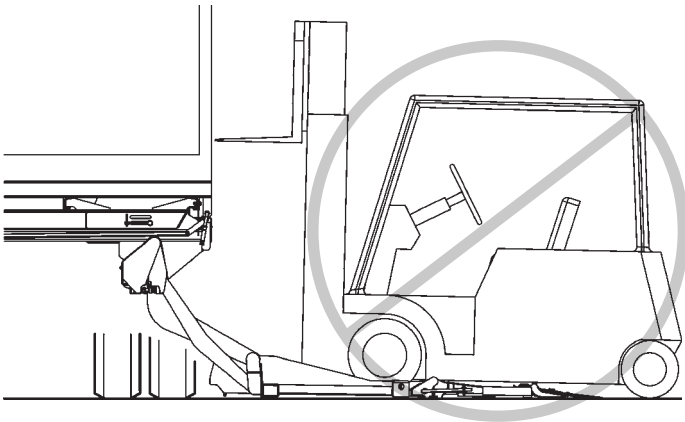
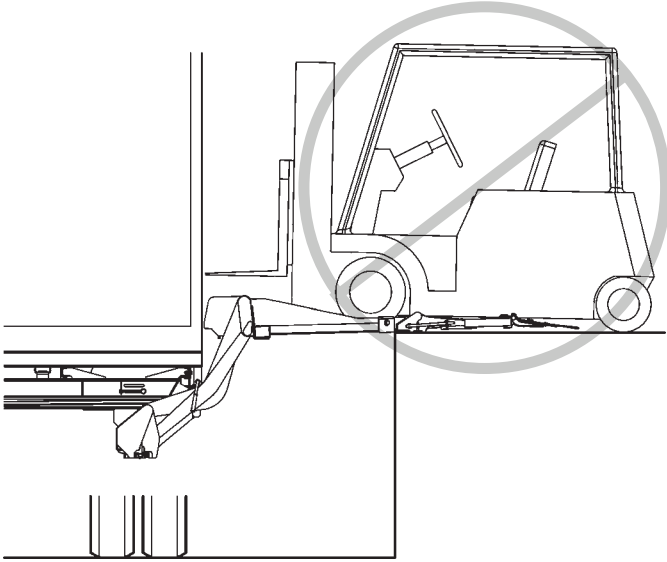

FIG. 14-1

OPERATION

CAUTION

Ensure Liftgate is unchained before you deploy Liftgate for operation. Possible injury and equipment damage could result.

1. Tap **UP** toggle switch (**FIG. 15-1**) to take pressure off the chain.

UP-DOWN
TOGGLE SWITCH

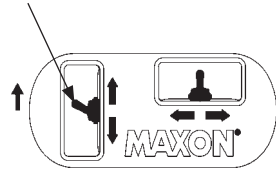

UP
FIG. 15-1

2. Unchain Liftgate by unhooking snap hook from the platform (**FIG. 15-2**).

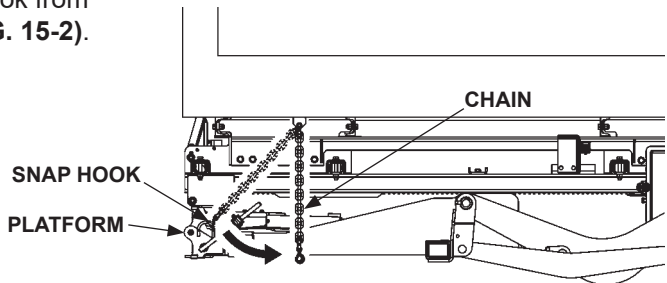

UNCHAINING LIFTGATE
FIG. 15-2

OPERATION - Continued

CAUTION

To prevent damage to Liftgate & vehicle, Liftgate will not travel in or out from vehicle unless platform is at a certain height. To enable in and out travel, ensure platform is approximately 6" above the ground at its lowest point.

NOTE: If necessary, release toggle switch to stop platform from moving.

3. Hold the up-down toggle switch in the **DOWN** position (FIG. 16-1) until platform is approximately 6" above the ground (FIG. 16-2).

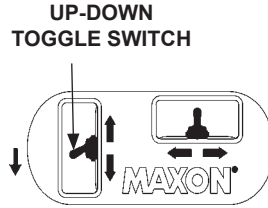

DOWN
FIG. 16-1

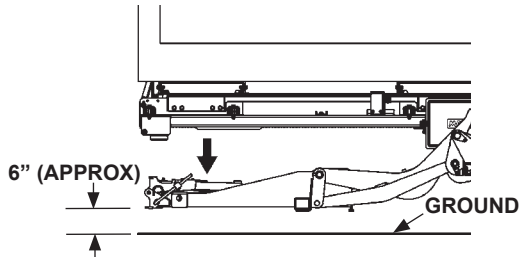

PLATFORM LOWERED 6" ABOVE GROUND
FIG. 16-2

NOTE: Platform must be released from latch before Liftgate can slide out.

4. Pull the latch release handle forward (**FIG. 17-1A**). Next, hold the in-out toggle switch in the **OUT** position (**FIG. 17-1B**), and release latch handle as the Liftgate travels to the outboard stops as shown in **FIG. 17-1**.

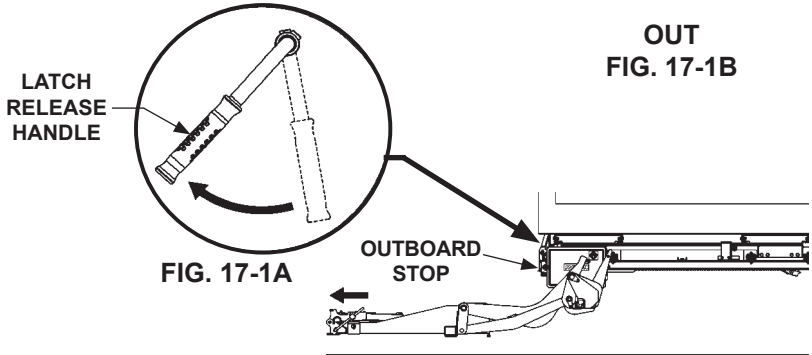

LIFTGATE TRAVELS TO OUTBOARD STOPS
FIG. 17-1

⚠ WARNING

Never operate control switch while unfolding the platform.

5. Unfold the flipover (if equipped) (**FIG. 17-2**).

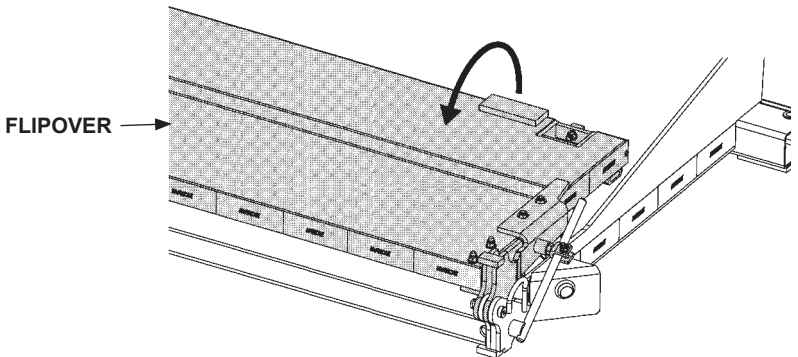

UNFOLD FLIPOVER
FIG. 17-2

OPERATION - Continued

CAUTION

To prevent damage to Liftgate & vehicle, platform should not be raised to bed height unless Liftgate is in position at the outboard stops. To enable full raise and lower operation, ensure Liftgate is at the outboard stops.

6. Hold the up-down toggle switch in the **DOWN** position (FIG. 18-1A) to lower platform to ground level (FIG. 18-1).

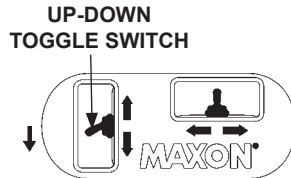

DOWN
FIG. 18-1A

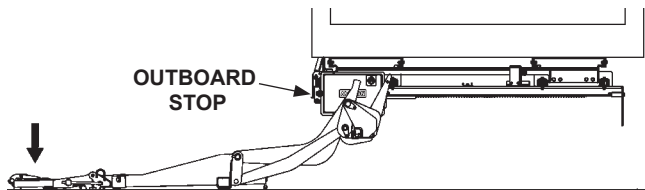

PLATFORM LOWERED TO GROUND
FIG. 18-1

WARNING

To prevent possible injury, never operate control switch while unfolding the flipover or retention ramp.

7. If equipped with a flipover and retention ramp, unfold retention ramp (FIG. 18-2) by pushing down on locking arm. Then, pull strap **UP** and rotate ramp **UP** (FIG. 18-2).

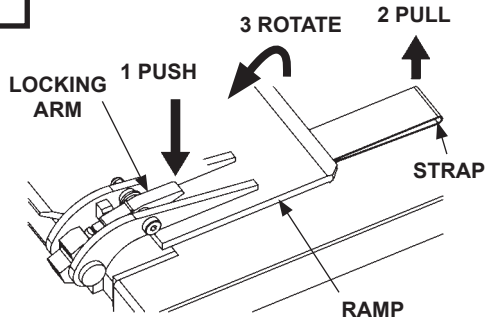

UNFOLDING RETENTION RAMP
(RH SIDE SHOWN)
FIG. 18-2

CAUTION

A ramp in retention position can trip you when stepping over it. To prevent possible injury, get on the platform before putting the ramp in retention position.

8. To release RH ramp from the catch, push down on locking arm while lifting up on the strap. Then, pull ramp up to disengage from the catch. Repeat for LH ramp, if equipped (FIG. 19-1).

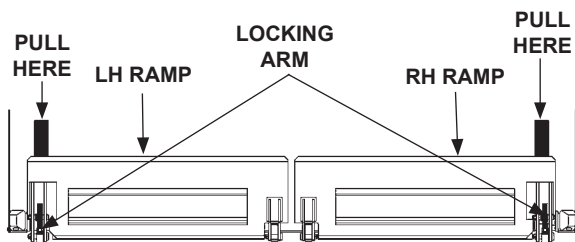

**RELEASING RETENTION RAMP
(TOP VIEW)
FIG. 19-1**

9. Once the retention ramp is disengaged from the locking arm, pull the retention ramp to the retention position (FIG. 19-2). Repeat for LH ramp, if equipped.

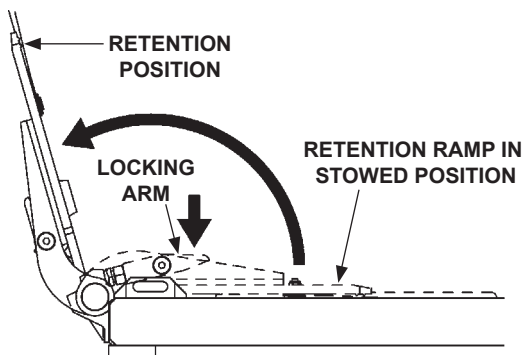

**MOVING RAMP TO RETENTION POSITION
(RH SIDE SHOWN)
FIG. 19-2**

OPERATION - Continued

⚠ CAUTION

To prevent injuries, stay clear of the retention ramp path as it moves to ramp position. Go to either side of the ramp and stay out of the way.

10. Push the locking arm and pull retention ramp to the ramp position (**FIG. 20-1**).

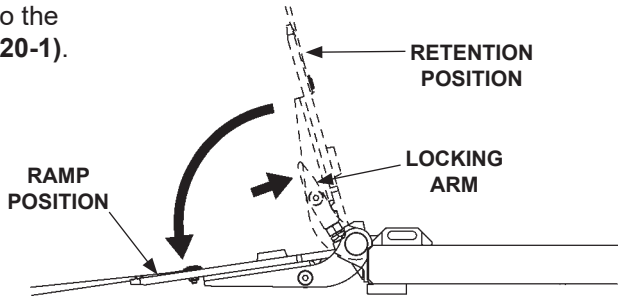

**MOVING TO RAMP POSITION
(RH SIDE SHOWN)
FIG. 20-1**

⚠ CAUTION

To prevent damage to the retention ramp, before raising or lowering platform, retention ramp should be in the retention or stowed position.

NOTE: If necessary, release the toggle switch to stop the platform from moving.

11. To raise platform to bed level (FIG. 21-1), hold the up-down toggle switch in the **UP** position (FIG. 21-1A).

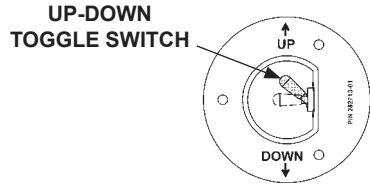

UP
FIG. 21-1A

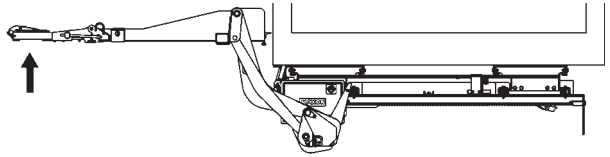

PLATFORM RAISED TO BED LEVEL
FIG. 21-1

12. To lower platform to ground level (FIG. 21-2), hold the up-down toggle switch in the **DOWN** position (FIG. 21-2A).

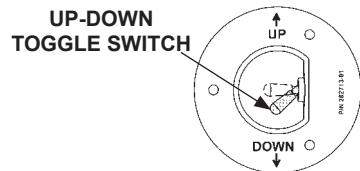

DOWN
FIG. 21-2A

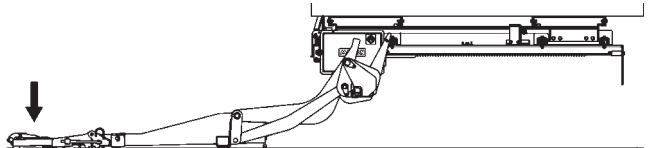

PLATFORM LOWERED TO GROUND
FIG. 21-2

OPERATION - Continued

WARNING

A load should never extend past the edges of the platform. Do not place unstable loads on platform and do not allow load to exceed the lifting capacity of the Liftgate. If standing on platform, do not allow your feet to extend beyond the inboard edge of the platform.

13. Move load on platform (FIG. 22-1). If equipped, rotate retention ramp to retention position (FIG. 22-2). Then, stand in the area of the footprints as shown in FIG. 22-1.

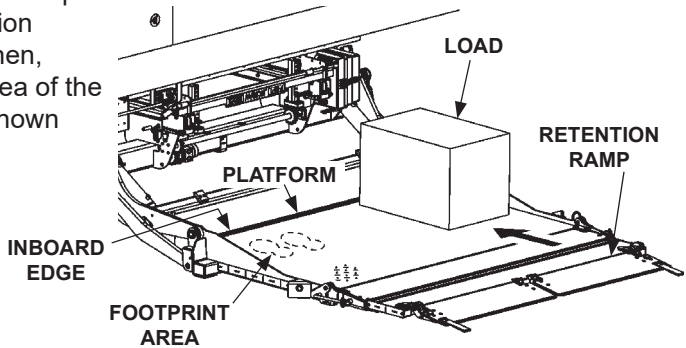

LOADING PLATFORM AT GROUND LEVEL
FIG. 22-1

NOTE: Ensure vehicle door is latched open before raising platform to bed level.

14. Raise platform to bed level (FIG. 22-2). Then, move load from platform into vehicle body.

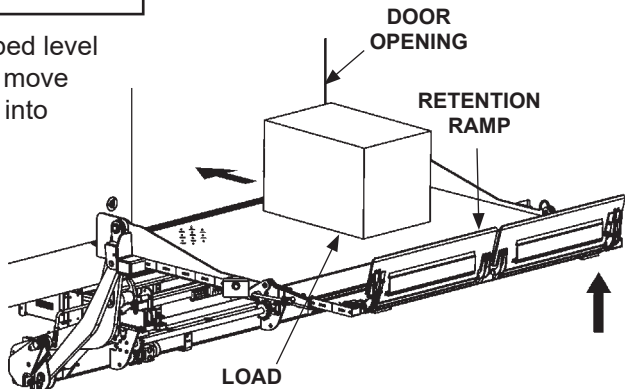

UNLOADING PLATFORM AT BED LEVEL
FIG. 22-2

WARNING

Pulling the load from vehicle to platform can result in a fall from platform and serious injury. When unloading vehicle, always push the load out on the platform.

15. Load the platform at bed level as follows. Push load out of the vehicle body to the center of the platform with the heaviest part toward the trailer body (FIG. 23-1). If standing on platform with the load, stand in the footprint area shown and comply with the **WARNING** on the previous page.

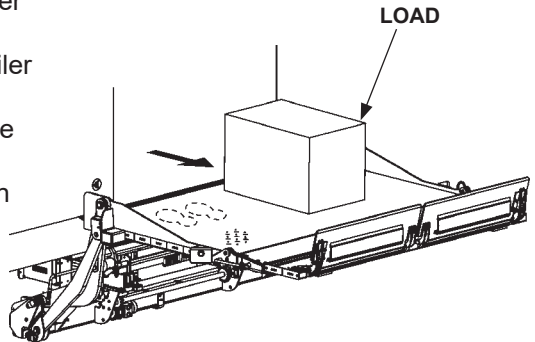

LOADING PLATFORM AT BED LEVEL
FIG. 23-1

16. Lower platform to ground level (FIG. 23-2). If equipped, rotate retention ramp(s) to ramp position (FIG. 23-2). Then, move load off the platform.

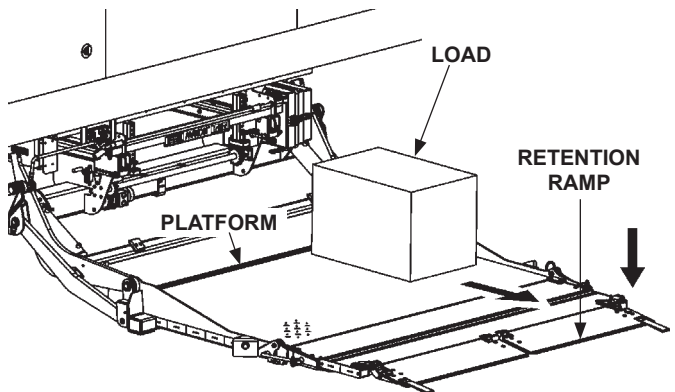

UNLOADING PLATFORM AT GROUND LEVEL
FIG. 23-2

OPERATION - Continued

WARNING

Never operate control switch while folding the flipover or retention ramp.

17. To stow, rotate retention ramp to stow position as shown in (FIG. 24-1). Repeat for LH ramp, if equipped with dual retention ramps.

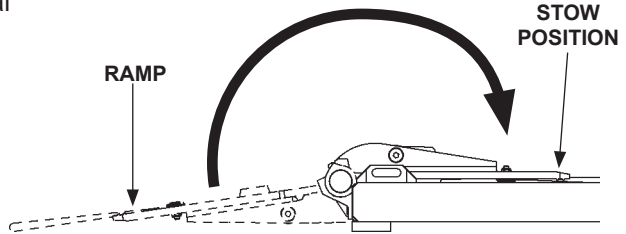

**ROTATING RAMP TO STOWED POSITION
(RH SIDE SHOWN)**

FIG. 24-1

18. Push the retention ramp down into the catch (FIG. 24-2). Make sure locking arm is fully locked into catch (FIG. 24-2). Repeat for LH ramp, if equipped with dual retention ramps.

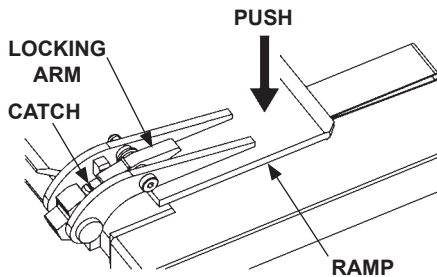

**FOLDING RETENTION RAMP
(RH SIDE SHOWN)**

FIG. 24-2

CAUTION

To prevent damage to Liftgate & vehicle, Liftgate will not travel in or out from vehicle unless platform is at a certain height. To enable in and out travel, ensure platform is approximately 6" above the ground at its lowest point.

NOTE: If necessary, release the toggle switch to stop the platform from moving.

19. Hold the up-down toggle switch in the **UP** position (FIG. 25-1) until platform is approximately 6" above the ground (FIG. 25-2).

UP-DOWN
TOGGLE SWITCH

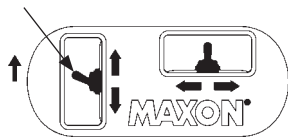

UP
FIG. 25-1

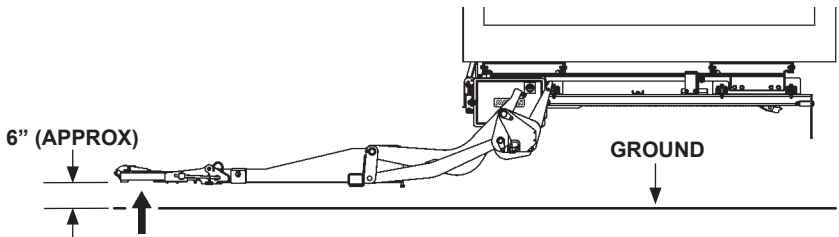

PLATFORM RAISED 6" ABOVE GROUND
FIG. 25-2

20. Fold flipover on top of platform (FIG. 25-3).

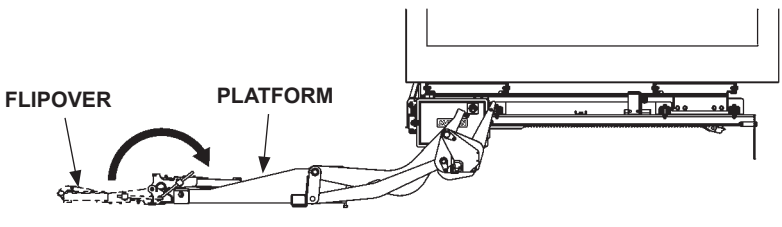

FOLDING FLIPOVER
FIG. 25-3

OPERATION - Continued

CAUTION

To prevent damage to Liftgate & vehicle, platform cannot be raised to stow position unless Liftgate is **ALL THE WAY IN** at the inboard stops. To enable platform to be raised, ensure Liftgate is at the inboard stops.

21. To stow Liftgate, hold the in-out toggle switch in the **IN** position (**FIG. 26-1**). Then, let Liftgate travel all the way to inboard stop as shown in **FIG. 26-2**. Movement of the latch release handle (**FIG. 26-2A**) indicates slider is latched.

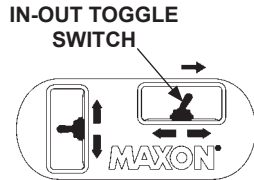

IN
FIG. 26-1

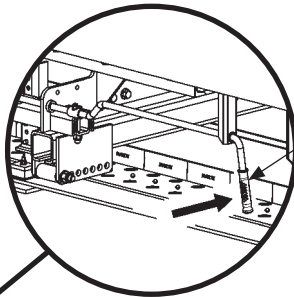
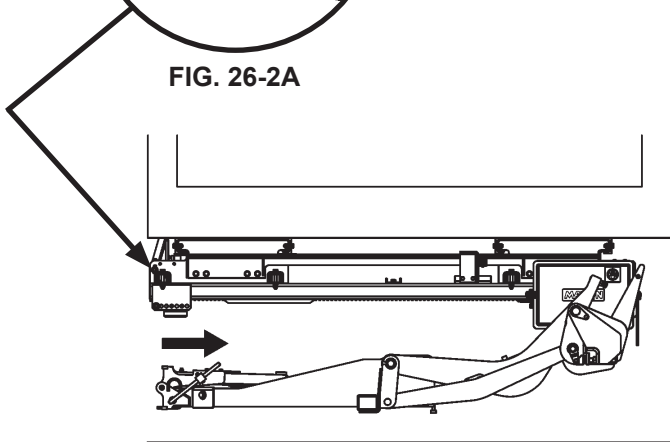

FIG. 26-2A



SLIDING PLATFORM IN TO STOW
FIG. 26-2

CAUTION

Platform must be stowed against frame under hydraulic pressure.

22. Hold the up-down toggle switch in the **UP** position (**FIG. 27-1**) until the platform raises up against the bumpers (**FIGS. 27-2 and 27-2A**). Then release toggle switch. Platform flashing lights turn off.

UP-DOWN
TOGGLE SWITCH

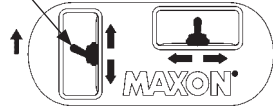

UP
FIG. 27-1

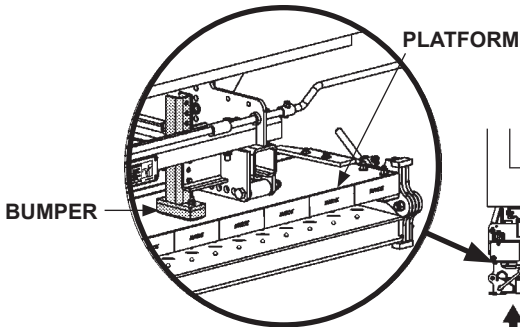

FIG. 27-2A

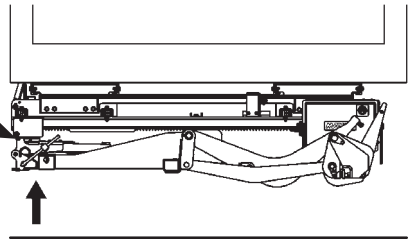
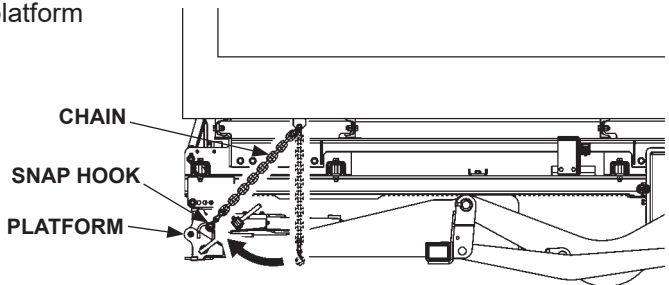

FIG. 27-2

⚠ CAUTION

Ensure Liftgate is chained before moving the vehicle. Possible injury and equipment damage could result.

23. Hook chain to platform (**FIG. 27-3**).



CHAINING LIFTGATE
FIG. 27-3

OPERATION - Continued

NOTE: Stow light illuminates when the Liftgate is not in the stow position.

24. Before moving vehicle, ensure stow light is off (**FIG. 28-1**).

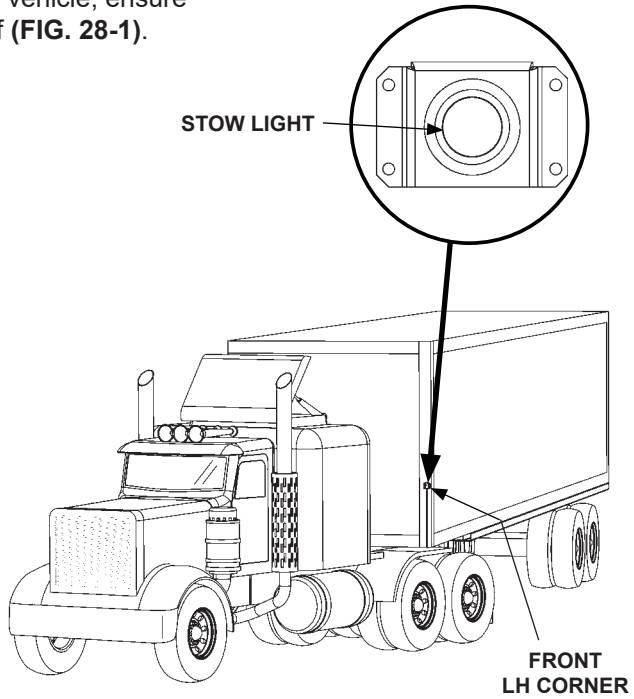

FRONT OF TRAILER
FIG. 28-1

