



January 21, 2015

ANNOUNCEMENT

Product Update: MAXON Updates Frameless Trailer Kit Instructions

Please take note that the Frameless Trailer Kit instructions have been changed in reference to welding to trailer cross members for applicable Tuk-A-Way® models.

Updated [M-Sheets](#) have been uploaded to our website.

3. If slider rail is not welded to each of the crossmembers as shown, weld the RH trailer slider rail to each crossmember above mount bracket as shown in **FIG. 5-1**. Repeat for LH slider rail.

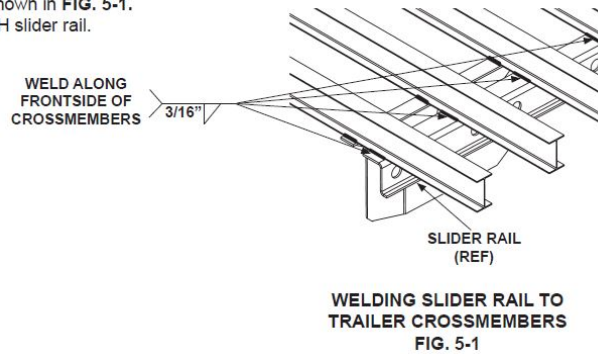

For more information on product updates, please contact Customer Service at (800) 227-4116 or visit us at www.maxonlift.com.

CALENDAR OF EVENTS

Technology & Maintenance Council (TMC)

February 16-18, 2015
Nashville, TN

National Truck Equipment Association (NTEA) - The Work Truck Show

March 4-6, 2015
Indianapolis, IN

Truck Renting and Leasing Association (TRALA)

March 13-15, 2015
Amelia Island, FL

National Private Truck Council (NPTC)

April 26 - 28, 2015
Cincinnati, OH
Booth #424

Hawaiian Transportation Association (HTA)

August 28, 2015
Big Island, HI

ExpoTransporte ANPACT

Nov 18-20, 2015
Guadalajara, Mexico

Maxon Lift Corp.-Marketing Department
11921 Slauson Avenue, Santa Fe Springs, CA 90670-2221
(800)227-4116 | (562)464-0099

www.maxonlift.com

[Unsubscribe or update your email preferences by selecting this link.](#)

