

M-16-14  
REV. B  
JUNE 2020

**Operation Manual Contains:**

- Warnings
- Decal & Plate Locations
- Standard Control Locations
- Liftgate & Retention Ramp Operation

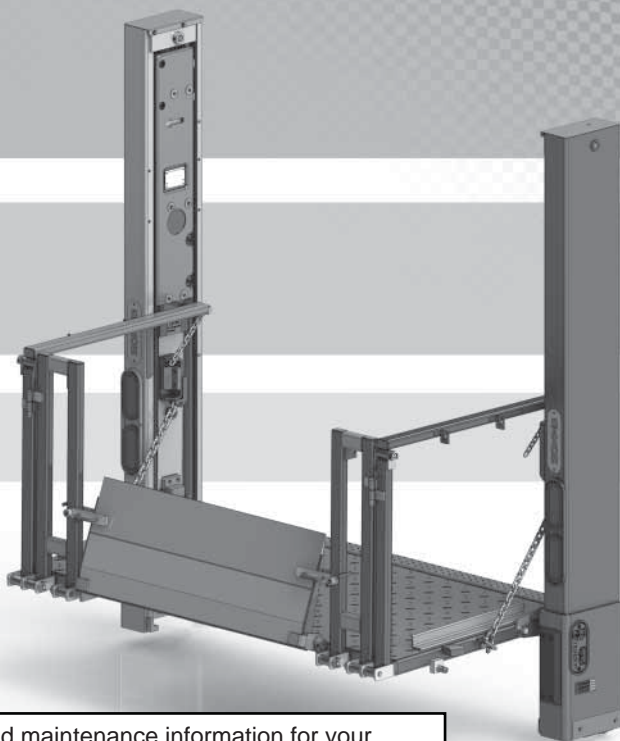

**MAXON**<sup>®</sup>  
**LIFT CORP.**

To find maintenance information for your **BMR-CS Liftgate**, go to [www.maxonlift.com](http://www.maxonlift.com). Click the **PRODUCTS, COLUMNLIFT & BMR-CS** buttons. Open the **Maintenance Manual** in the **PRODUCT DOCUMENTATION** window. For parts, click on the **PARTS PORTAL, COLUMNLIFT & BMR-CS** buttons.

© MAXON Lift Corp.2020

# BMR-CS

## OPERATION MANUAL

**KEEP THIS MANUAL IN CAB OF VEHICLE**

Register your liftgate on line at [www.maxonlift.com/html/services/reg.htm](http://www.maxonlift.com/html/services/reg.htm). For a free copy of other manuals that pertain to this model liftgate, please visit our website at [www.maxonlift.com](http://www.maxonlift.com) or customer service at (800) 227-4116.



# TABLE OF CONTENTS

<b>SUMMARY OF CHANGES: M-16-14, REVISION B.....</b>	<b>5</b>
<b>WARNINGS.....</b>	<b>6</b>
<b>RECOMMENDED DAILY OPERATION CHECKS.....</b>	<b>8</b>
DECALS & PLATES .....	10
STANDARD CONTROL LOCATIONS .....	12
POWER DOWN CONTROLS (IF EQUIPPED) .....	13
PUMP BOX CONTROLS.....	14
<b>FORKLIFT ADVISORY .....</b>	<b>15</b>
<b>LOADING VEHICLE .....</b>	<b>16</b>
OPENING THE PLATFORM .....	16
LOWERING THE PLATFORM .....	16
OPENING THE RETENTION RAMP - STEEL PLATFORM.....	17
OPENING THE RETENTION RAMP - ALUMINUM PLATFORM.....	18
POSITIONING LOAD .....	19
<b>UNLOADING VEHICLE .....</b>	<b>22</b>
OPENING THE PLATFORM .....	22
RAISING THE PLATFORM .....	23
LOWERING & UNLOADING PLATFORM.....	25
STOWING PLATFORM.....	27
STOW RETENTION RAMP.....	27
STOW PLATFORM .....	28
DOCK LOADING & UNLOADING .....	30
LOWER PLATFORM BELOW DOCK LEVEL.....	30



# SUMMARY OF CHANGES: M-16-14, REVISION B

PAGE	DESCRIPTION OF CHANGE
<b>COVER</b>	Updated REV. and date of release.
<b>8, 9</b>	Added Recommended Daily Operational Checks.
<b>10</b>	Added QR Code Decal (P/N 299350-01) to decal locations image.
<b>11</b>	Updated decal sheet Decal "F", Operating Instructions, to include QR Code Decal.

## **WARNING**

1. Incorrect operation of this Liftgate can result in serious personal injury. Comply with **WARNINGS** and Liftgate operating instructions in this manual. Do not allow untrained persons or children to operate the Liftgate. If you need to replace an **Operation Manual**, additional copies are available from:

**MAXON Lift Corp. Customer Service**  
**11921 Slauson Ave**  
**Santa Fe Springs, CA 90670**  
**(800) 227-4116**

2. Do not exceed rated **load capacity** of the Liftgates which is **3500 lbs. for model BMR-CS3500, and 4400 lbs. for model BMR-CS44.**
3. Do not allow any part of your body to be placed under, within, or around any portion of the moving Liftgate or its mechanisms, or in a position that would trap them between the platform and the floor of truck body (or between platform and the ground) when Liftgate is operated.
4. Consider the safety and location of bystanders and location of nearby objects when operating the Liftgate. Stand to one side of platform while operating the Liftgate. Be certain that the area the Liftgate will move through during operation is clear of all obstacles.
5. Comply with all attached instruction decals and warning decals.
6. Keep decals clean and legible. If decals are illegible or missing, have them replaced. **Get free replacement decals from Maxon.**
7. **Never drive a forklift on the Liftgate platform.**
8. Do not move vehicle unless Liftgate is correctly stowed.
9. **Correctly stow platform when not in use. Extended platforms could create a hazard for people and vehicles passing by.**
10. A correctly installed Liftgate will operate smoothly and reasonably quiet. The only noticeable noise, during Liftgate operation, is from the power unit while the platform is being unfolded, lowered (power down only), raised, or folded. Listen for scraping, grating and binding noises and have the problem corrected before continuing to operate the Liftgate.
11. Above all, **USE GOOD COMMON SENSE** when operating this Liftgate.
12. Never use a cell phone while operating the Liftgate.

**THIS PAGE INTENTIONALLY LEFT BLANK**

# RECOMMENDED DAILY OPERATION CHECKS

**NOTE:** Before you check the Liftgate, park vehicle on flat ground and set the parking brake.

**NOTE:** If any of the following operation checks reveal a need to service or repair Liftgate, do not operate the Liftgate until a qualified mechanic services or repairs the Liftgate.

## Before operating the Liftgate, the operator should do the following:

- Make sure batteries are fully charged, battery terminal connections are clean and tight, and battery box is undamaged.
- Make sure cab cutoff switch is **ON**, if equipped.
- Visually check that pump cover is bolted on securely and undamaged. Look for hydraulic fluid leaking from the pump box.
- Follow the routing of hydraulic hoses from cylinders to pump box. Make sure all hoses are connected at both ends and there are no cracks, chafing, and fluid leaks.
- Visually check that standard and optional controls are in place and undamaged.
- Visually check that all decals are in place (see **DECALS** page). Make sure decals are legible, clean, and undamaged.

## Use the operation instructions in this manual to unfold the platform and lower it to the ground.

- Check for smooth operation as platform unfolds and as runners lower the platform to the ground.
- Check main frame, extension plate, columns, runners and platform openers for cracks and bends. Make sure platform chains are undamaged and connected securely at both ends. Also, make sure all bolts and pins are in place and undamaged.
- Check platform and flipover for cracks, holes, and bends on the load-carrying surfaces and side plates. Also, make sure retention ramps and carts stops (if equipped) are undamaged and operate smoothly.
- Make sure load-carrying surfaces on extension plate, platform, flipover, and retention ramp (if equipped) are clean (no oil, debris, or corrosion).
- Check for fluid leaks from hydraulic cylinders.



**Use the operation instructions in this manual to operate the Liftgate through one cycle without a load on the platform. Raise the platform to vehicle bed height. Next, lower the platform to ground level.**

- When raising and lowering platform, listen for unusual noises and look for a “jerking” motion or uneven movement at LH and RH sides of the platform. Uneven movement should not exceed 1”.
- With platform at bed height, make sure the LH and RH platform chains feel even in tightness.
- Retention ramps (if equipped) release, unfold and fold smoothly, and remains in ramp, retention, and stowed positions until intentionally moved.
- Carts stops (if equipped) release, open, and close smoothly and remain so until intentionally opened or stowed.

**If service or repairs are not required (or if completed), stow platform for transport.**

# DECALS & PLATES

**NOTE:** Ensure there is no residue, dirt, or corrosion where decals are attached. If necessary, clean surface before attaching decals.

**NOTE:** Decals on the Liftgate are attached at the factory.

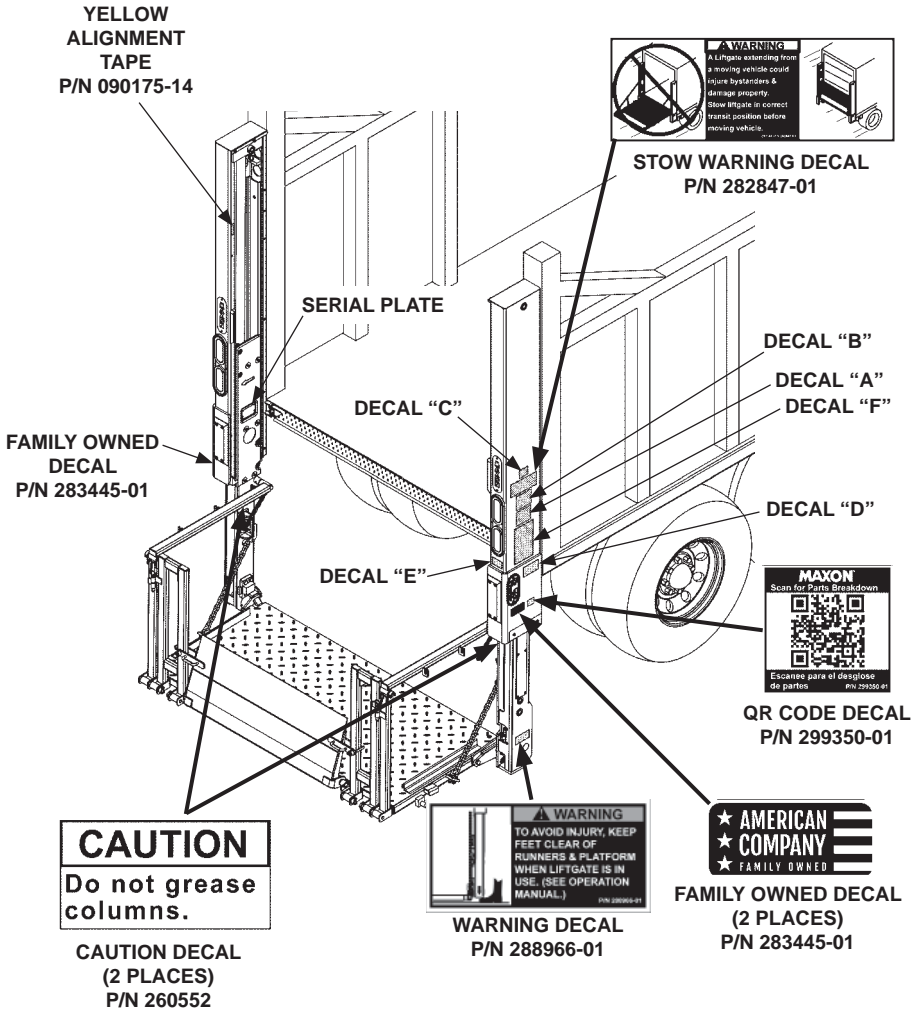

FIG. 10-1

**⚠ WARNING**  
Read this information carefully.

- Improper operation of this Liftgate can result in serious personal injury. If you do not have a copy of the operating instructions, please obtain them from your employer, distributor, or lessor before you attempt to operate Liftgate.
- If there are signs of improper maintenance, damage to vital parts, or slippery platform surface, do not use the Liftgate until these problems have been corrected.
- If you are using a pallet jack, be sure it can be maneuvered safely.
- Do not operate a forklift on the platform.
- Do not allow any part of yours or your helper's body to be placed under, within, or around any portion of the moving Liftgate, or its mechanisms, or in a position that would trap them between the platform and the ground or truck when the Liftgate is operated.
- If a helper is riding the platform with you, make sure you are both doing so safely and that you are not in danger of coming in contact with any moving or potentially moving obstacles.
- **USE GOOD COMMON SENSE.**
- If load appears to be unsafe, do not lift or lower it.

For a free copy of other manuals that pertain to this model Liftgate, please visit our website at [www.maxonlift.com](http://www.maxonlift.com) or call Customer Service at (800) 227-4116.

**⚠ WARNING**  
Liftgate hazards can result in crushing or falling.  
Keep hands and feet clear of pinch points.  
If riding liftgate, make sure load is stable and footing is solid.

Read and understand all instructions and WARNINGS before use.

**SAFETY INSTRUCTIONS**  
Read all decals and operation manual before operating liftgate.

1. Do not use liftgate unless you have been properly instructed and have read, and are familiar with, the operating instructions.
2. Be certain vehicle is properly and securely braked before using the liftgate.
3. Always inspect this liftgate for maintenance or damage before using it. Do not use liftgate if it shows any sign of damage or improper maintenance.
4. Do not overload.
5. Make certain the area in which the platform will open and close is clear before opening or closing the platform.
6. Make certain platform area, including the area in which loads may fall from platform, is clear before and at all times during operation of liftgate.
7. This liftgate is intended for loading and unloading of cargo only. Do not use this liftgate for anything but its intended use.

**OPERATING INSTRUCTIONS**

Scan this QR code to see operation manual or video.

OPERATE	STOW
<p><b>1 LOWER RUNNERS TO LINE UP YELLOW ARROW WITH YELLOW STRIPE. THIS SHOWS PLATFORM IS CLEAR TO UNFOLD.</b></p>	<p><b>1 RAISE PLATFORM TO LINE UP YELLOW ARROW WITH YELLOW STRIPE. THIS SHOWS PLATFORM IS CLEAR TO FOLD.</b></p>
<p><b>2 UNFOLD PLATFORM</b></p>	<p><b>2 FOLD PLATFORM</b></p>
<p><b>3 LOWER PLATFORM. IF IT IS SLOW TO LOWER &amp; LIFTGATE IS POWER DOWN EQUIPPED, PUSH POWER DOWN BUTTON.</b> <b>2 - RAISE PLATFORM. POWER DOWN BUTTON IF EQUIPPED.</b></p>	<p><b>3 RAISE RUNNERS TO STOW PLATFORM.</b></p>

PN 289163 01

**THE MAXIMUM CAPACITY OF THIS LIFT IS**  
**\_\_\_ LB [ \_\_\_ KG ]**  
**WHEN THE LOAD IS CENTERED ON THE LOAD CARRYING PLATFORM**

(REFER TO TABLE 11-1)

**⚠ CAUTION**  
Always stand clear of platform area.

**DECAL SHEET**  
**FIG. 11-1**

MODEL	ORDER P/N	DECAL "C"
BMR-CS-35	289163-01	3500 LBS. [1600 KG]
BMR-CS-44	289163-02	4400 LBS. [2000 KG]

**DECAL SHEET PART NUMBERS**  
**TABLE 11-1**

# STANDARD CONTROL LOCATIONS

## GROUND ACCESS - COLUMN SWITCH

Toggle switches on column switch (FIG. 12-1A) let operator raise (**UP**), lower (**DOWN**), **FOLD**, and **UNFOLD** the platform (FIG. 12-1) while standing on the ground.

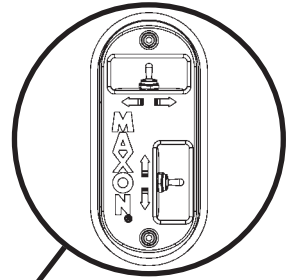
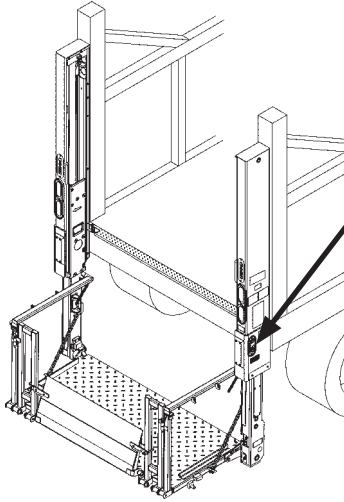

FIG. 12-1A

FIG. 12-1

## PLATFORM ACCESS - RUNNER SWITCH

Toggle switch (FIG. 12-2A) on RH runner lets operator raise (**UP**) and lower (**DOWN**) the platform (FIG. 12-2) only. Switch stays within reach when operator rides platform **UP** and **DOWN**.

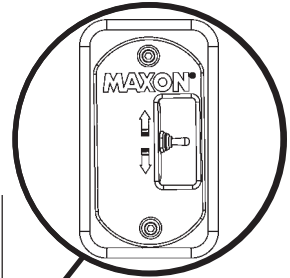
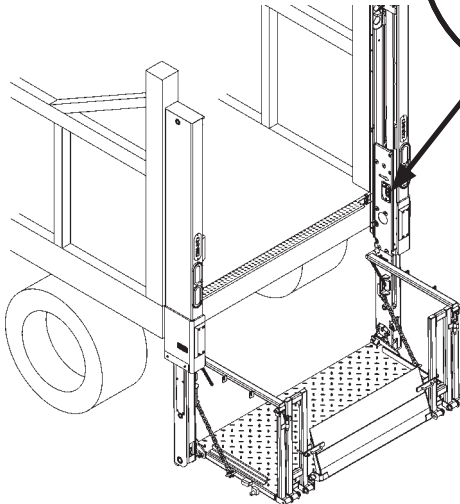

FIG. 12-2A

FIG. 12-2

# POWER DOWN CONTROLS (IF EQUIPPED)

## GROUND ACCESS - COLUMN SWITCH

**POWER DOWN** button (if equipped) on column switch (FIG. 13-1A) lets operator lower platform by pressing the **POWER DOWN** button once and pushing and holding the toggle switch (**DOWN**) (FIG. 13-1B), while standing on the ground. The **POWER DOWN** button (FIG. 13-1A) illuminates to indicate the power down function is activated.

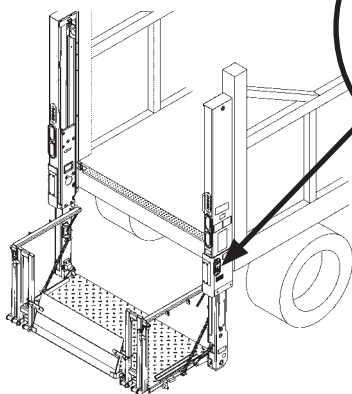

FIG. 13-1B

### POWER DOWN BUTTON

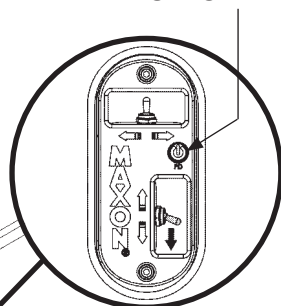

FIG. 13-1A

## PLATFORM ACCESS - RUNNER SWITCH

**POWER DOWN** button (if equipped) on runner switch (FIG. 13-2A) lets operator lower platform by pressing the **POWER DOWN** button once and pushing and holding the toggle switch (**DOWN**) (FIG. 13-2B), while standing on the platform. The **POWER DOWN** button (FIG. 13-2A) illuminates to indicate the power down function is activated.

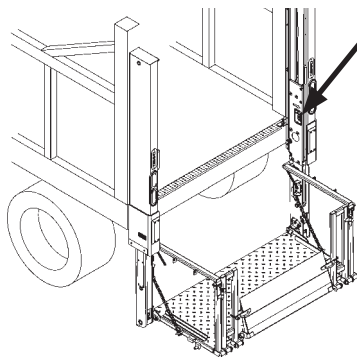

FIG. 13-2B

### POWER DOWN BUTTON

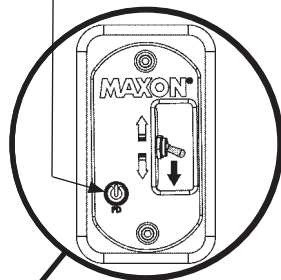
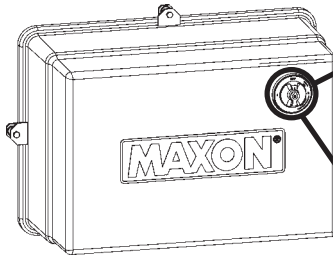

FIG. 13-2A

# PUMP BOX CONTROLS

## MASTER SELECT SWITCH

The master select switch (**FIGS. 14-1, 14-1A and 14-1B**) applies or removes battery power from the pump(s). For a single pump box (**FIG. 14-1A**), turn the **MASTER SELECT SWITCH** to **1** to operate Liftgate.



**SINGLE PUMP BOX  
FIG. 14-1**

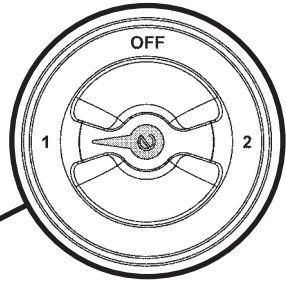

**MASTER SELECT  
SWITCH  
(PUMP 1 SELECTED)  
FIG. 14-1A**

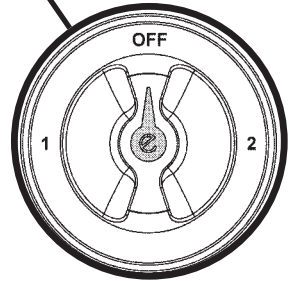

**MASTER SELECT  
SWITCH (OFF)  
FIG. 14-1B**

If the Liftgate is equipped with a dual pump box, the **MASTER SELECT SWITCH (FIG. 14-1A)** can be used to connect battery power to either pump **1** or pump **2** to power Liftgate. To remove battery power from pumps **1** and **2**, turn switch **OFF (FIG. 14-1B)**.

# FORKLIFT ADVISORY

**⚠ WARNING**  
**Keep forklift OFF of platform.**

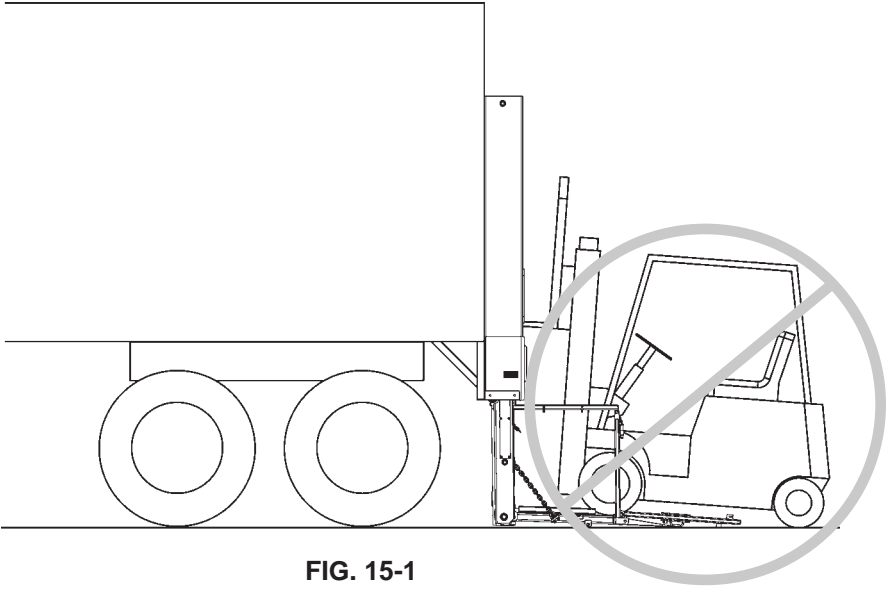

**FIG. 15-1**

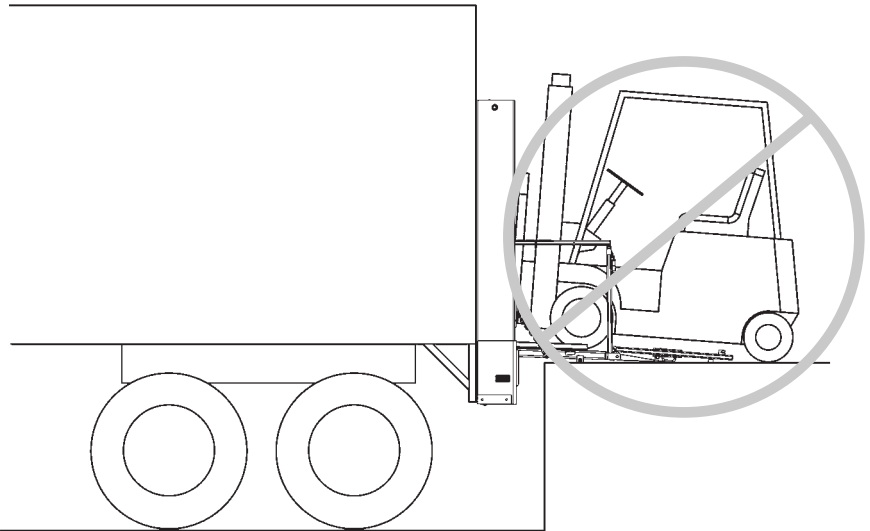
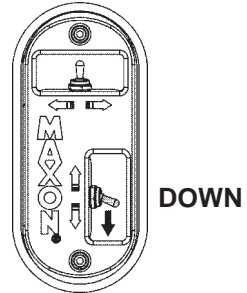

**FIG. 15-2**

# LOADING VEHICLE OPENING THE PLATFORM

**NOTE:** The 2 platform flashing lights are flashing when platform is unfolding and unfolded. The lights stop flashing when the platform is folded/stowed.

Push toggle switch to **DOWN** position (**FIG. 16-1**) to lower platform until runner arrow and yellow tape are about even (**FIG. 16-2A**). Platform will be released from the locking wedges on the Liftgate column. Next, use column switches **1** and **2** to **UNFOLD** platform (**FIG. 16-2**). Hold both toggle switches until platform reaches the unfolded (horizontal) position and then release the switches.



**COLUMN SWITCH**  
**FIG. 16-1**

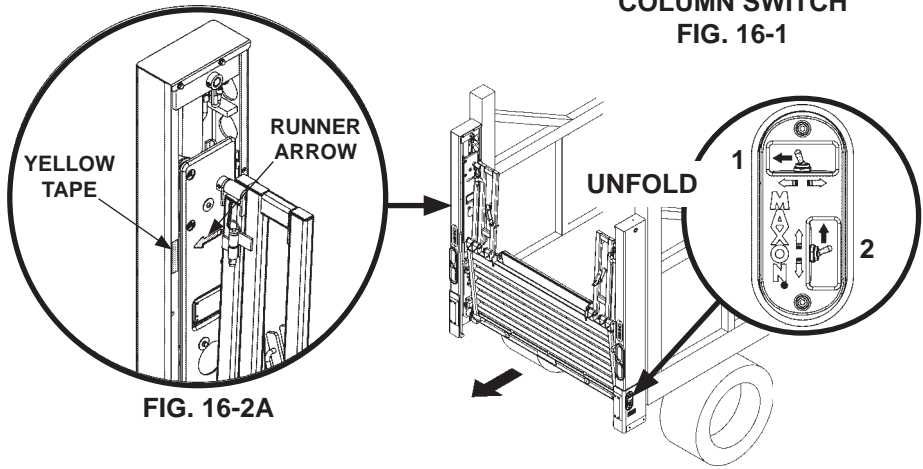

**FIG. 16-2**

## LOWERING THE PLATFORM

To lower platform to the ground, use column switch as shown in **FIG. 16-3**. Release toggle switch when platform reaches the ground.

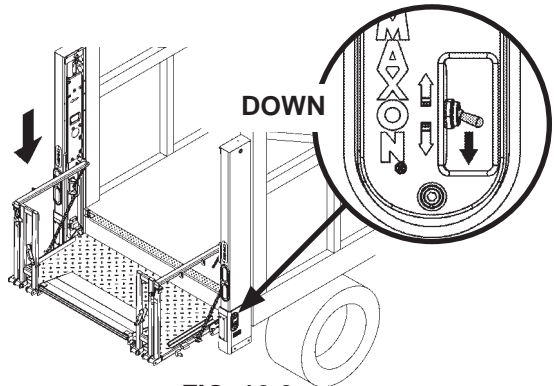
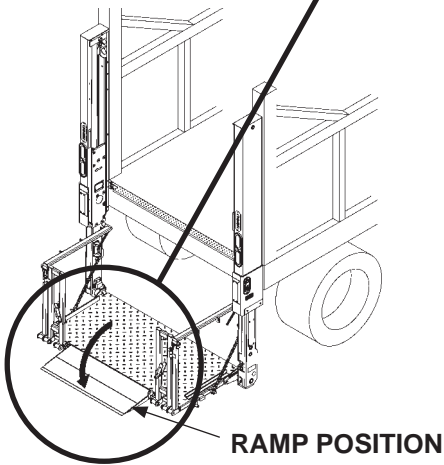
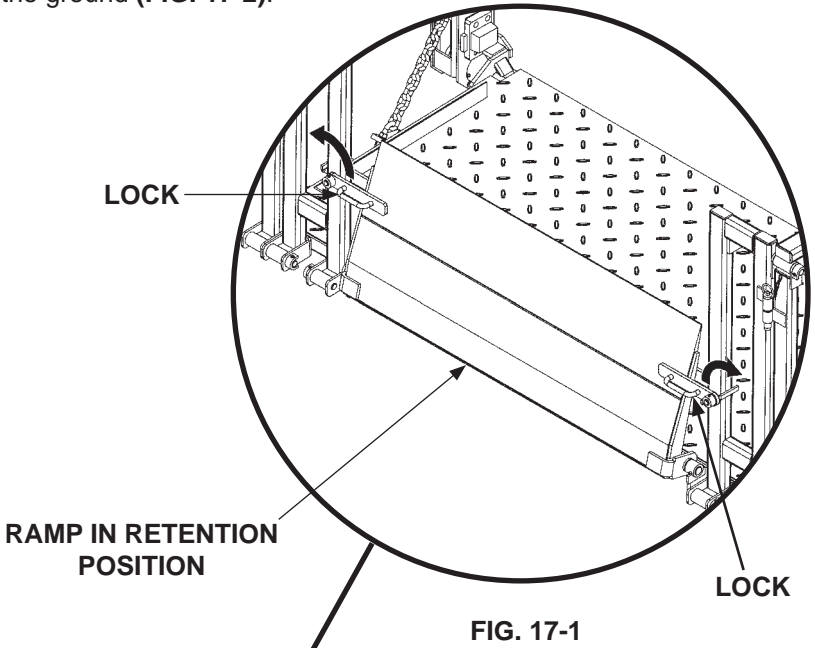

**FIG. 16-3**



# OPENING THE RETENTION RAMP - STEEL PLATFORM

To release retention ramp, rotate locks in direction of arrows (FIG. 17-1) and unfold ramp to the ground (FIG. 17-2).



# LOADING VEHICLE - Continued

## OPENING THE RETENTION RAMP - ALUMINUM PLATFORM

To unfold retention ramp, first push down on retention ramp (**FIG. 18-1A**) to release tension on lock. Next, push down on lock mechanism (**FIG. 18-1B**) and lift the retention ramp until it is in the ramp position (**FIG. 18-1C**).

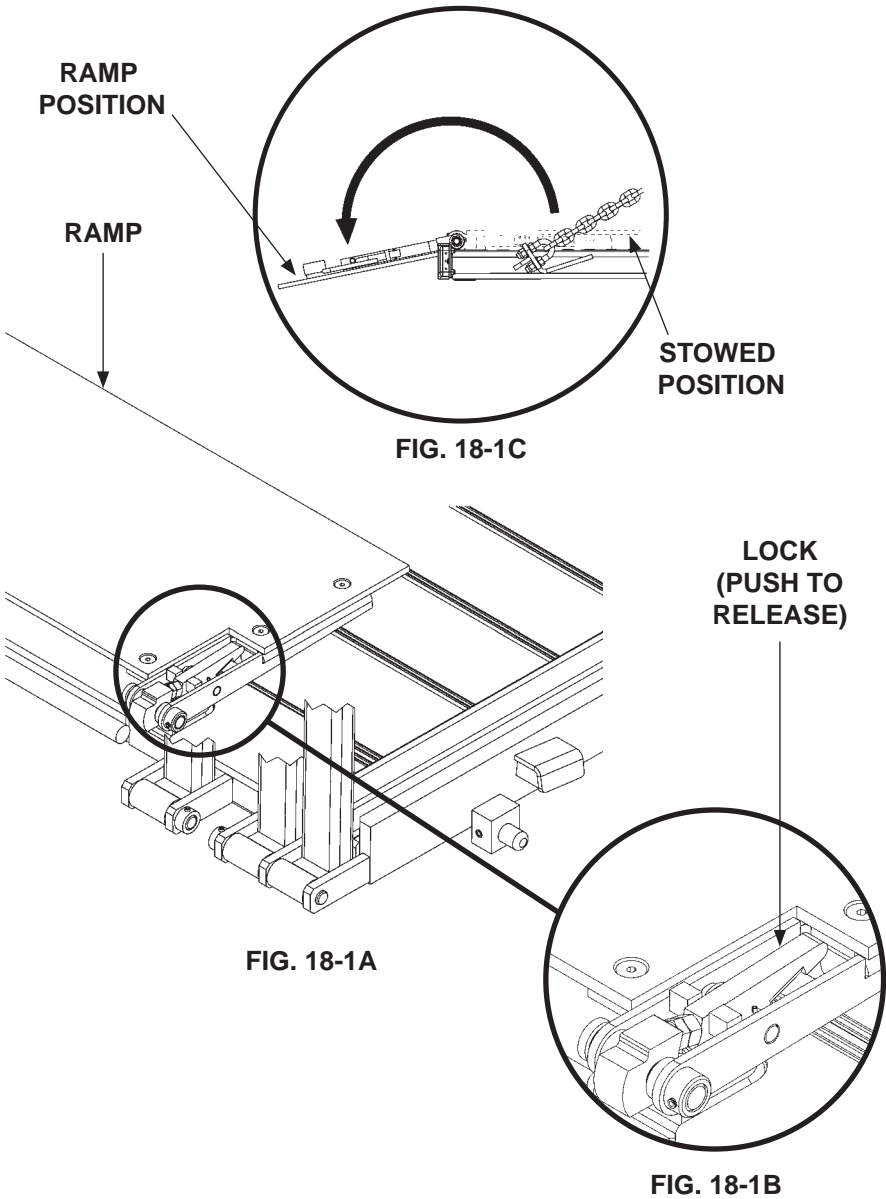

## POSITIONING LOAD

### **⚠ WARNING**

A load should never extend past the edges of the platform. Do not place unstable loads on platform and do not allow load to exceed lifting capacity of Liftgate. If standing on platform, do not allow your feet to extend beyond inboard edge of platform.

1. Place all loads as close as possible to the inboard edge of the platform with heaviest part toward the truck body as shown in **FIG. 19-1**.
2. Move loads across the ramp (**FIG. 19-1**) to the platform, but never rest or raise loads on the ramp. Make sure gas bottles rest against platform railing (**FIG. 19-1A**) and angle support (**FIG. 19-1B**).
3. Wrap chain around each gas bottle and hook onto platform railing as shown in **FIG. 19-1A**. If standing on platform with the load, stand in the footprint area shown (**FIG. 19-1**) and comply with the preceding **WARNING**.

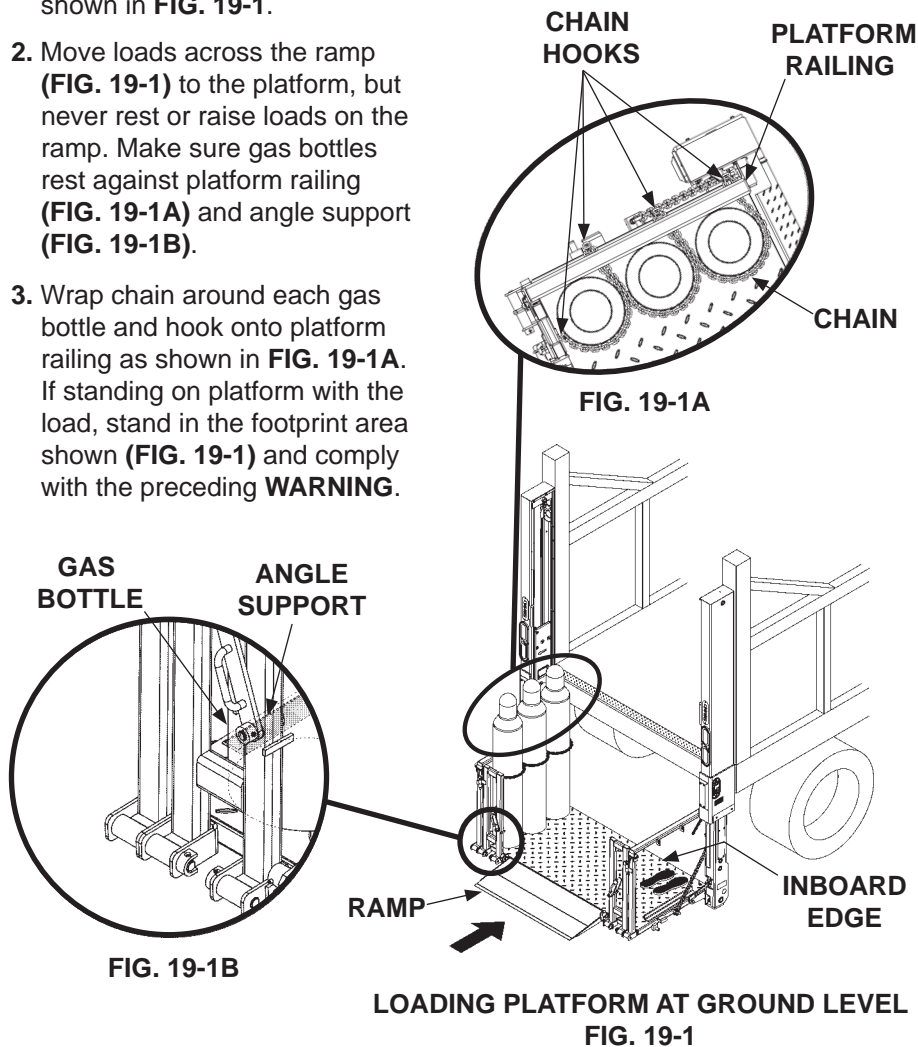

# LOADING VEHICLE - Continued

## RAISING & UNLOADING PLATFORM

### CAUTION

A ramp in retention position can trip you when stepping over it. To prevent possible injury, get on the platform before putting the ramp in retention position.

1. Fold ramp to retention position as follows:

#### STEEL PLATFORM

Fold ramp to retention position and rotate locks to secure ramp in position (**FIGS. 20-1 & 20-1A**).

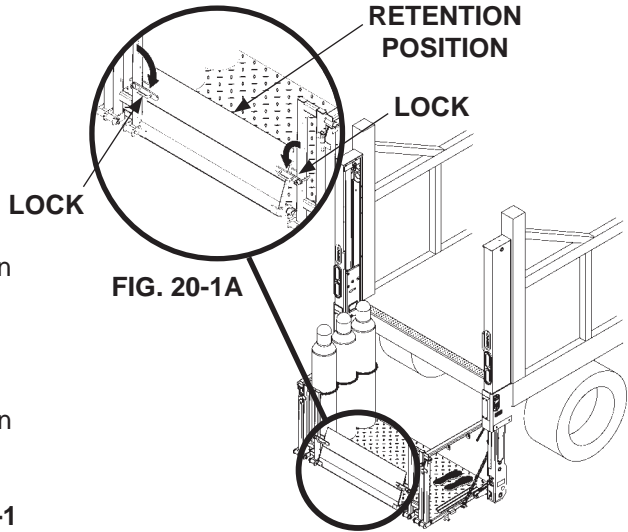

FIG. 20-1

#### ALUMINUM PLATFORM

Fold ramp until it locks in retention position (**FIG. 20-2**).

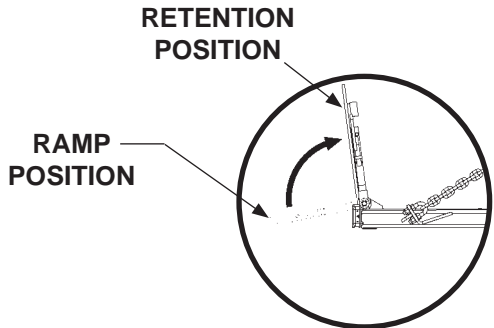
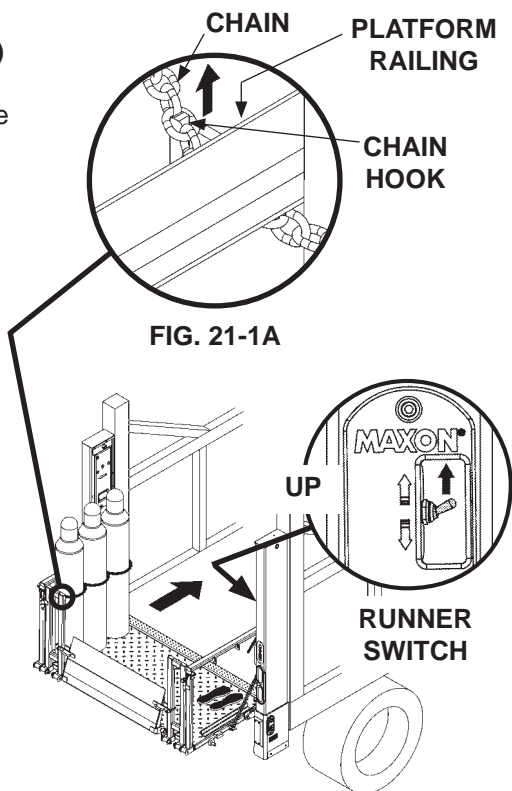

FIG. 20-2

2. Use runner switch to raise (**UP**) platform from ground level to bed height (**FIG. 21-1**). Release switch when platform reaches bed height.

3. Unhook chain from platform railing as shown in **FIG. 21-1A**. Carefully move the load into vehicle (**FIG. 21-1**).



**MOVING LOAD INTO VEHICLE**  
**FIG. 21-1**

4. Use runner switch to lower the platform to ground level (**FIG. 21-2**).

5. If there are more loads to put in vehicle, repeat the previous **LOADING VEHICLE** steps for each load. When loading is finished, use **STOWING PLATFORM** procedure in this manual.

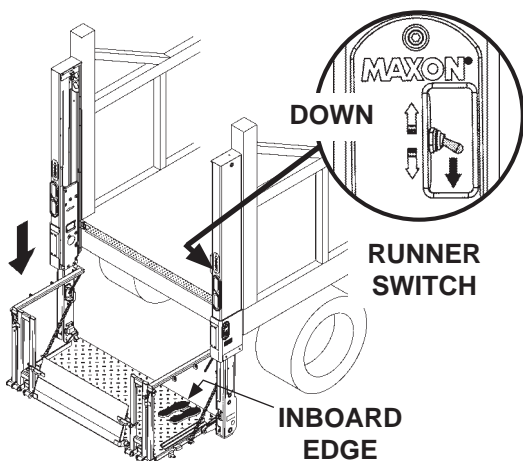

**FIG. 21-2**

# UNLOADING VEHICLE OPENING THE PLATFORM

Push column **UP/DOWN** toggle switch to **DOWN** position (**FIG. 22-1**) to lower platform (**FIG. 22-2A**) until runner arrow and column decal are about even (**FIG. 22-2B**). Platform will be released from the locking wedges on the Liftgate column. Next, use column switches **1** and **2** to **UNFOLD** platform (**FIG. 22-2A**). Hold both toggle switches until platform reaches the unfolded (horizontal) position and then release the switches.

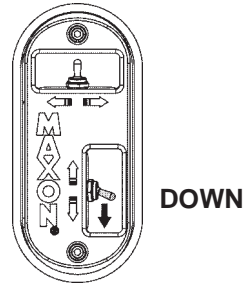

**COLUMN SWITCH**  
**FIG. 22-1**

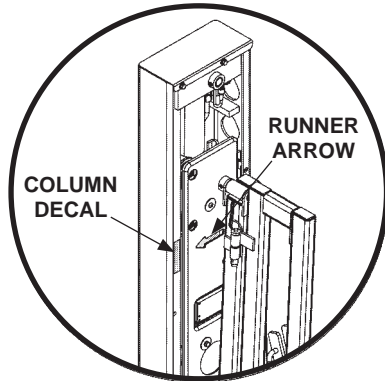

**FIG. 22-2B**

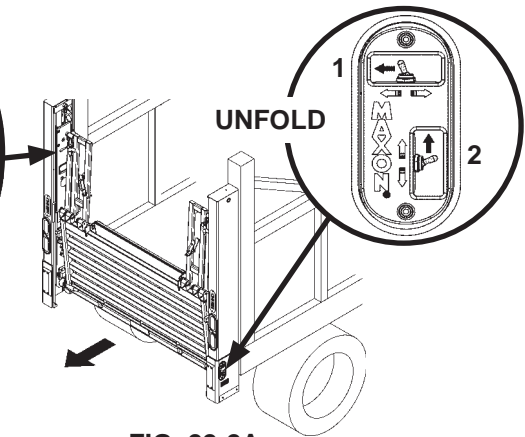

**FIG. 22-2A**

# LOWERING THE PLATFORM

To lower platform to the ground, use column switch as shown in **FIG. 22-3**. Release toggle switch when platform reaches the ground.

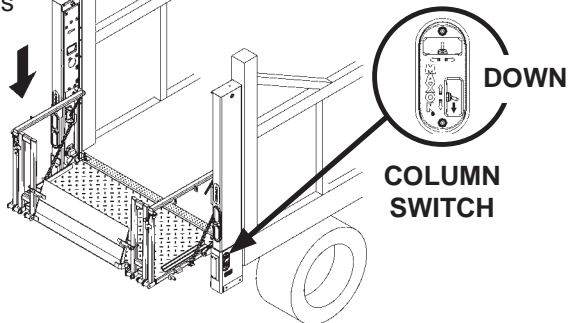

**FIG. 22-3**

## RAISING THE PLATFORM

Use runner switch to raise platform (FIG. 23-1) from ground level to bed height. Release switch when platform reaches bed height.

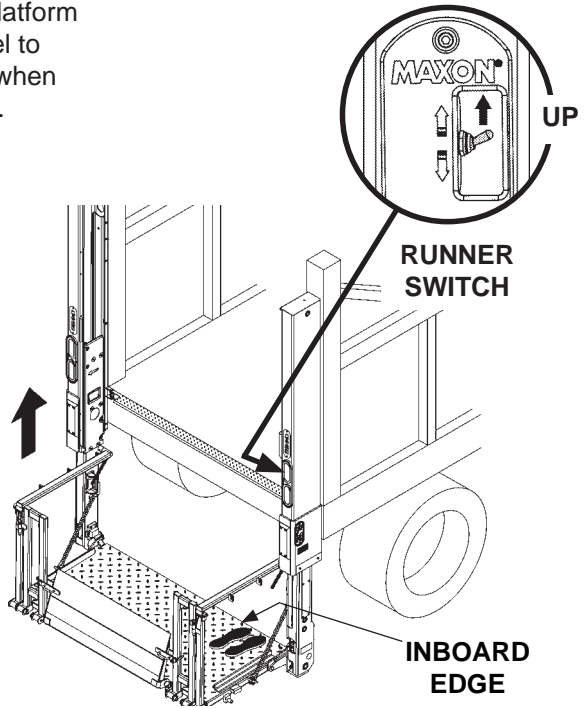

FIG. 23-1

# UNLOADING VEHICLE - Continued POSITIONING LOAD

## ⚠ WARNING

A load should never extend past the edges of the platform. Do not place unstable loads on platform and do not allow load to exceed lifting capacity of Liftgate. Load must not exceed maximum of 3 cylinders on each side of platform within the rated Liftgate capacity. If standing on platform, do not allow your feet to extend beyond inboard edge of platform.

## ⚠ WARNING

Pulling the load from vehicle to platform can result in a fall from platform and serious injury. When unloading vehicle, always push the load out on the platform.

1. Place all loads as close as possible to the inboard edge of the platform with heaviest part toward the truck body as shown in **FIG. 24-1**. Make sure load rests against platform railing (**FIG.24-1**) and angle support (**FIG. 24-1B**).

2. Wrap chain around each gas bottle and hook onto platform railing as shown in **FIG. 24-1A**. If standing on platform with the load, stand in the footprint area shown (**FIG. 24-1**) and comply with the preceding **WARNING**.

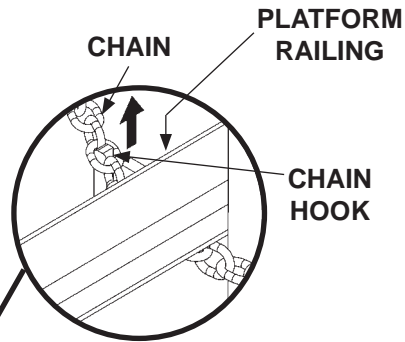

**FIG. 24-1A**

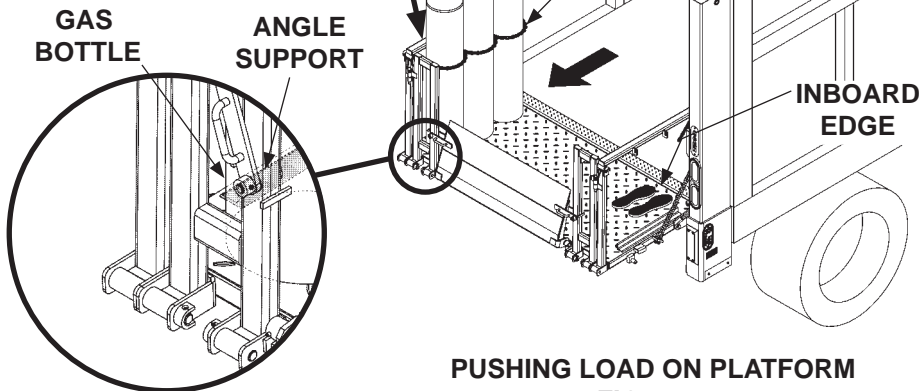

**FIG. 24-1B**

**PUSHING LOAD ON PLATFORM  
FIG. 24-1**



# LOWERING & UNLOADING PLATFORM

## **WARNING**

**Before lowering platform, make sure area surrounding platform is clear of people and objects. If standing on platform, do not allow your feet to extend beyond inboard edge of platform.**

1. Use runner switch to lower platform to the ground (**FIG. 25-1**). Release switch when platform reaches ground level.

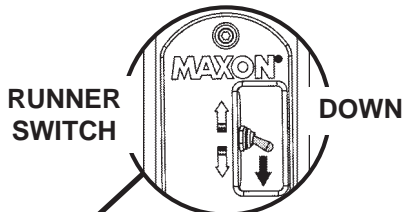

2. Unfold retention ramp to ramp position as follows:

### **STEEL PLATFORM**

Rotate locks (**FIG. 25-1A**) to release retention ramp. Unfold ramp to ramp position (**FIG. 25-1A**).

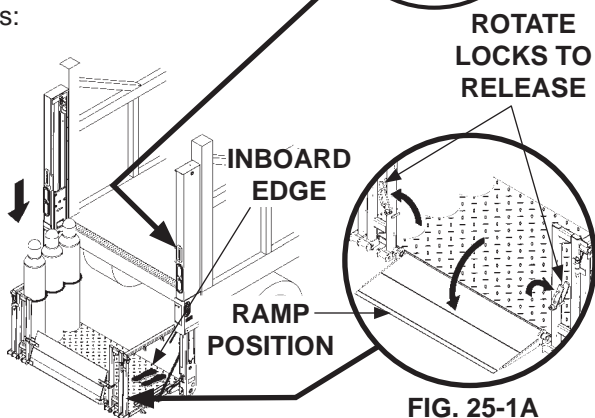

### **ALUMINUM PLATFORM**

Push down on lock mechanism and lower retention ramp to the ramp position (**FIG. 25-2**).

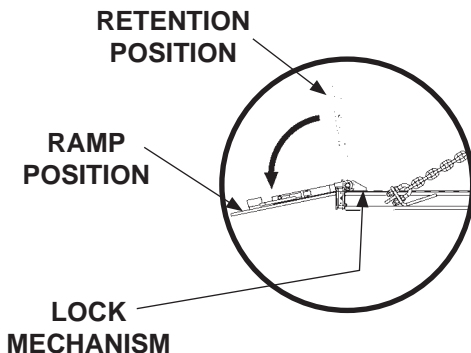

**FIG. 25-1**

**FIG. 25-2**

# UNLOADING VEHICLE - Continued

## LOWERING & UNLOADING PLATFORM - Continued

3. Unhook chain from platform railing (FIG. 26-1A).

4. Carefully move load off platform (FIG. 26-1) and then move it to a place where it will not become a hazard for people and other vehicles. If there is more to unload from vehicle, repeat the previous **UNLOADING VEHICLE** steps for each load. When unloading is finished, use **STOWING PLATFORM** procedure in this manual.

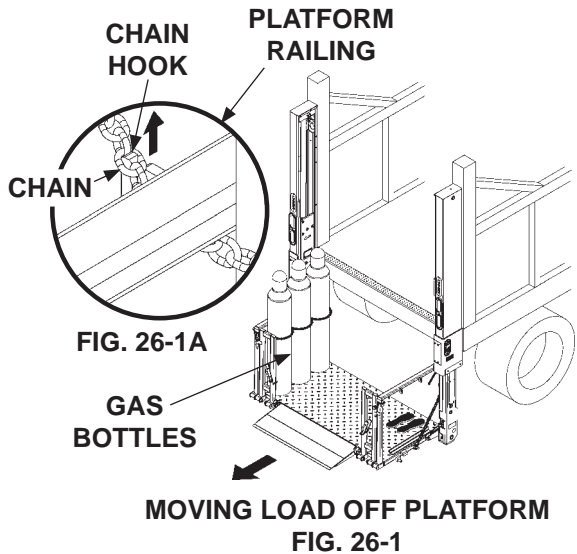

# STOWING PLATFORM STOW RETENTION RAMP

## STEEL PLATFORM

Fold ramp to stowed position as shown in FIGS. 27-1A & 27-1B.

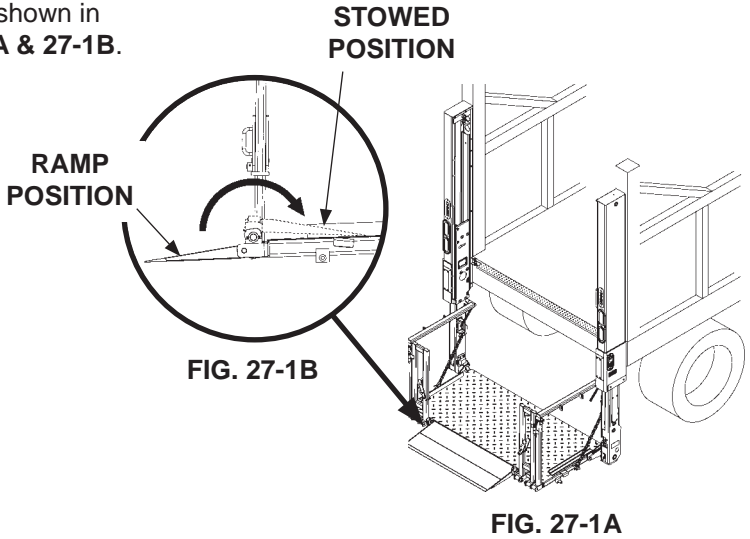

## ALUMINUM PLATFORM

Push ramp to stowed position until it locks, as shown in FIG. 27-2.

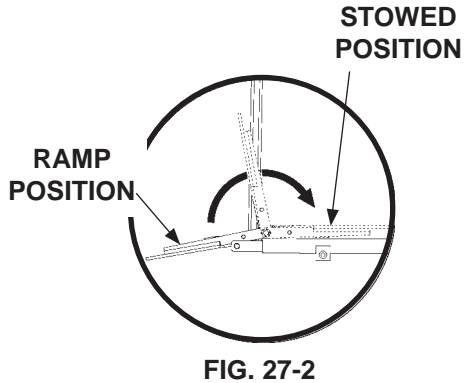

# STOWING PLATFORM - Continued

## STOW PLATFORM

### CAUTION

Platform and bottom stops could be damaged if platform is folded with heel below the column bottom stops. Bottom stops will interfere with folded platform being raised to up position. Prevent damage by aligning arrow decals on column & runner before folding platform. Then, platform heel will be above the bottom stops.

1. Use the column switch to raise (**UP**) platform (**FIG. 28-1A**) until runner arrow and column decal on LH column are aligned (**FIG. 28-1B**).

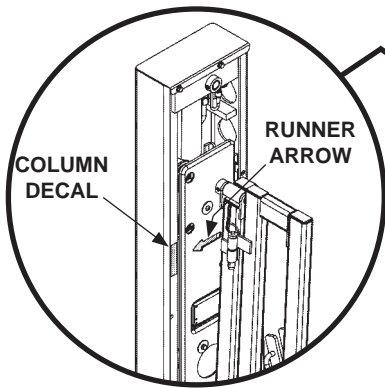

FIG. 28-1B

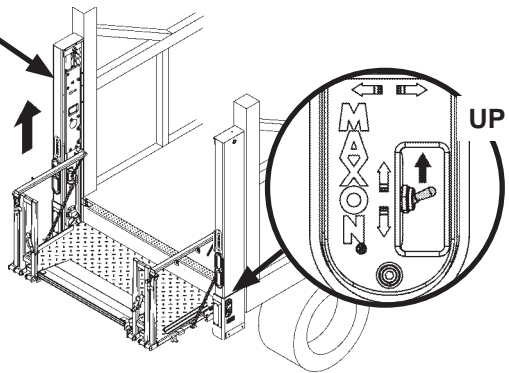

FIG. 28-1A

**NOTE:** The 2 platform flashing lights are flashing when platform is unfolding and unfolded. The lights stop flashing when the platform is folded/stowed.

2. Hold both column switches **1** and **2** to **FOLD** platform (**FIG. 28-2**).

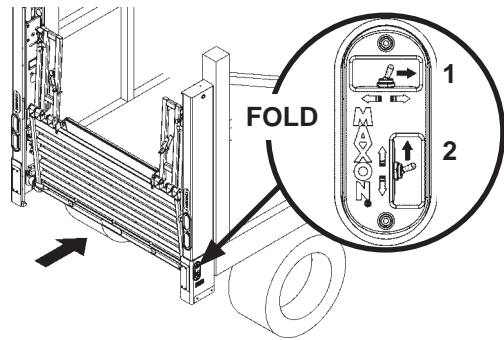
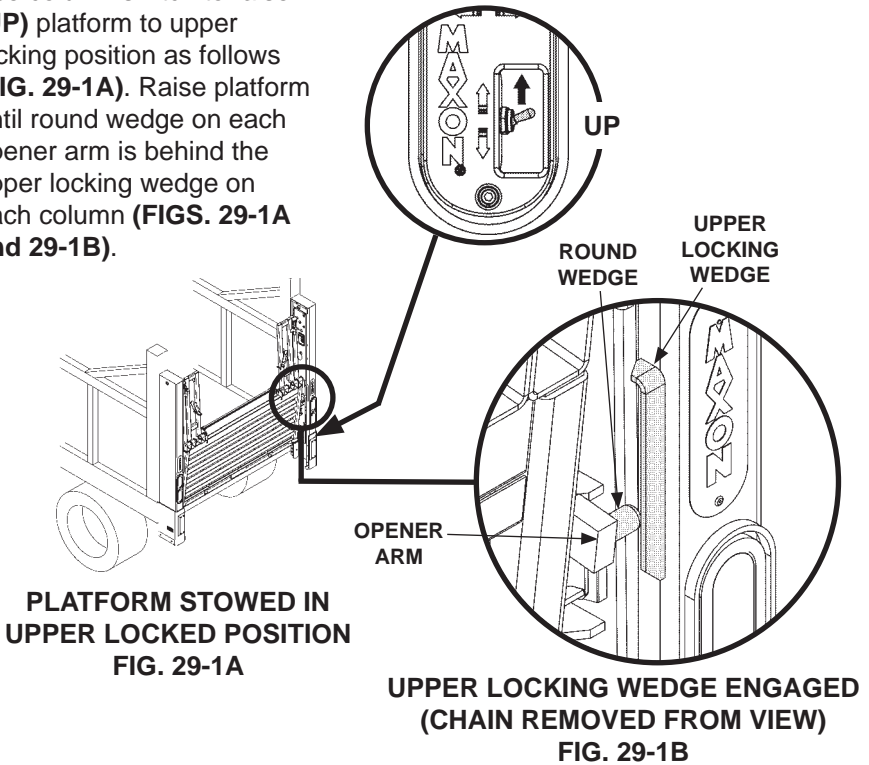

FIG. 28-2

## **⚠ WARNING**

**Upper locking wedges must be engaged before moving vehicle.**

3. Use column switch to raise **(UP)** platform to upper locking position as follows **(FIG. 29-1A)**. Raise platform until round wedge on each opener arm is behind the upper locking wedge on each column **(FIGS. 29-1A and 29-1B)**.



# DOCK LOADING & UNLOADING

## LOWER PLATFORM BELOW DOCK LEVEL

### CAUTION

Use dock plate for moving loads between dock and vehicle. Dock plate must be supported by dock and vehicle floor. It must not rest on Liftgate platform.

**NOTE:** Lower the platform and platform railing before backing vehicle to dock.

1. Use column switch to lower (**DOWN**) platform to lower locking position (**FIGS. 30-1 & 30-1A**). Release switch when top edge of closed platform is below bed height and resting on lower locking wedges (**FIG. 30-1A**).

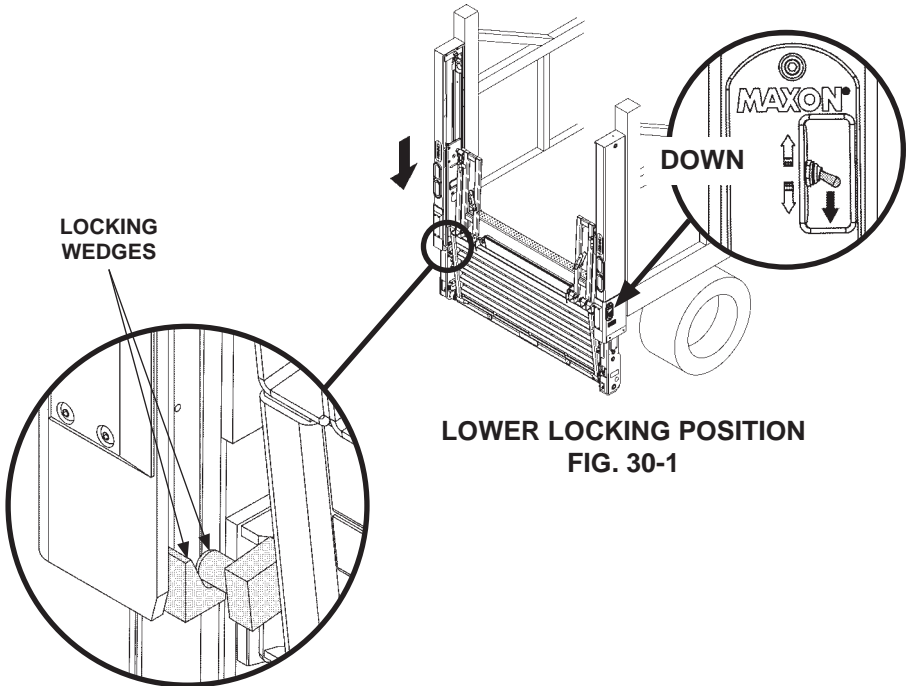
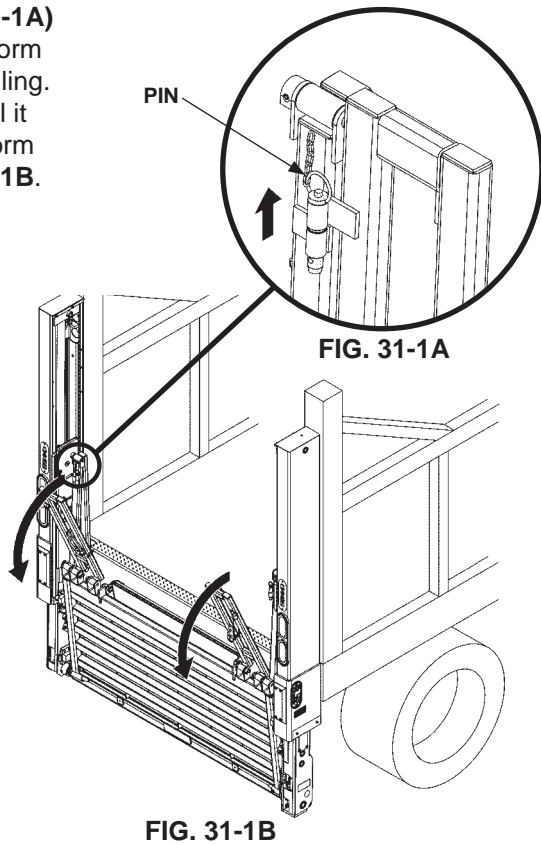

FIG. 30-1A

LOWER LOCKING POSITION  
FIG. 30-1

2. Remove pin (**FIG. 31-1A**) on each side of platform to unlock platform railing. Lower the railing until it hangs over the platform as shown in **FIG. 31-1B**.



**CAUTION**  
To prevent damage to Liftgate, use dock plate for moving loads between dock and vehicle.

3. Back up vehicle to dock (**FIG. 31-2**). Now loads can be moved between dock and vehicle.

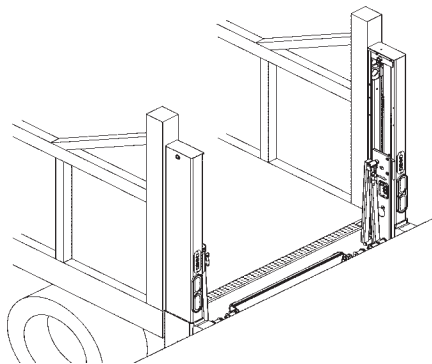

# DOCK LOADING & UNLOADING - Continued

## LOWER PLATFORM BELOW DOCK LEVEL - Continued

4. When finished loading and unloading from the dock, raise platform railing on each side of platform as shown in FIG. 32-1A. Pin platform railing to platform as shown in FIG. 32-1B.

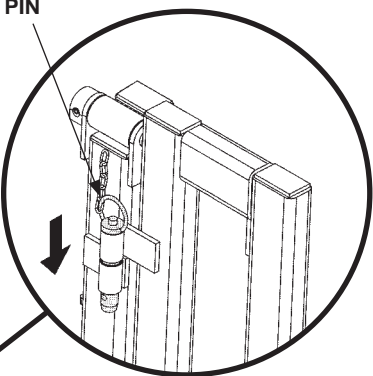

FIG. 32-1B

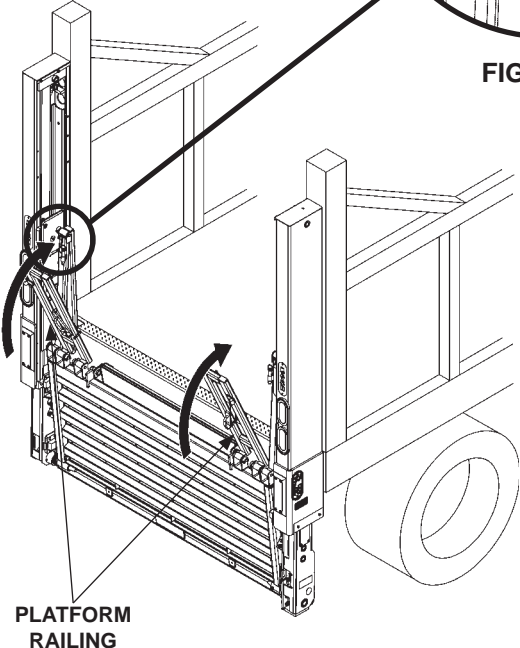

FIG. 32-1A



**⚠ WARNING**

**Upper locking wedges must be engaged before moving vehicle.**

5. Use column switch to raise (UP) platform to upper locking position as follows (FIG. 33-1A). Raise platform until round wedge on each opener arm is behind the upper locking wedge on each column (FIGS. 33-1A & 33-1B).

