

TC 24-KIT

Trailer or Refrigerated

MAXON®

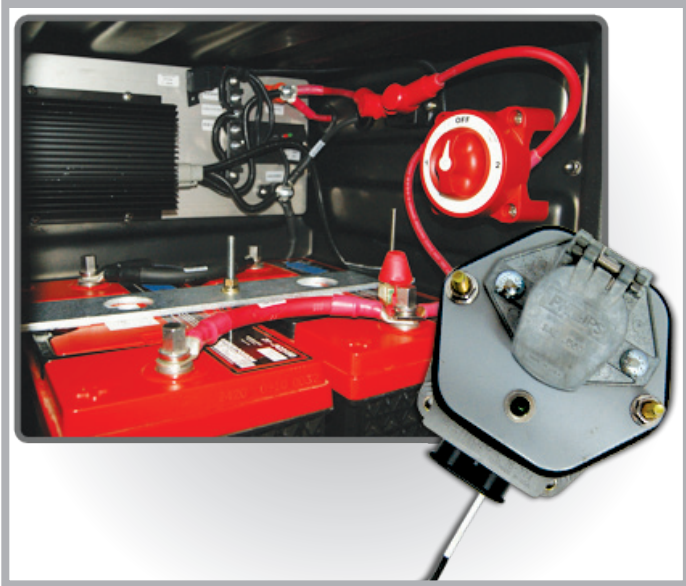

DESCRIPTION:

This system provides fleets the ability of recharging their auxiliary battery pack through either a traditional charge line method (dual pole) or a trail charger based solution that is housed inside of Maxon's new molded plastic battery box offering. Also included is an electronic module which is part of the trail charger based system that extends the charge time for up to an additional 30 minutes while still providing low voltage protection for the primary batteries. The system receives its power source from the dual pole receptacle. Kit includes the dual nose box, all cables and harnesses, a selector switch, a trail charger unit and a new molded plastic battery box.

RECOMMENDED FOR:

Trailer applications using an auxiliary battery source for powering the liftgate.

RECOMMENDED FOR:

Trail Charger powers off the tractors primary battery . The Trail Charger eliminates voltage drop issues by stepping up the voltage to meet the battery charging requirements.

Kit Content

Kit includes the combination nose box, all cables and harnesses, a selector switch, a trail charger unit that is factory installed inside of a new molded plastic battery box offering.

Note

Batteries shown in images are for illustration purposes only.

The issue:

On applications where auxiliary liftgate batteries are mounted a long distance from the primary vehicle's electrical system, voltage drop will occur. In order to charge auxiliary liftgate batteries, the correct voltage must be applied to these batteries. Without the correct voltage (i.e. electrical pressure) to push the available current through the liftgate batteries, inadequate recharging will occur and the batteries will run down.

The Solution:

Trail Charger Based Charging Solutions

A DC/DC converter (TRAIL CHARGER) eliminates the above problem by amplifying (boosting) any input voltage (9 to 14) to the correct voltage necessary to charge and maintain the liftgate batteries.

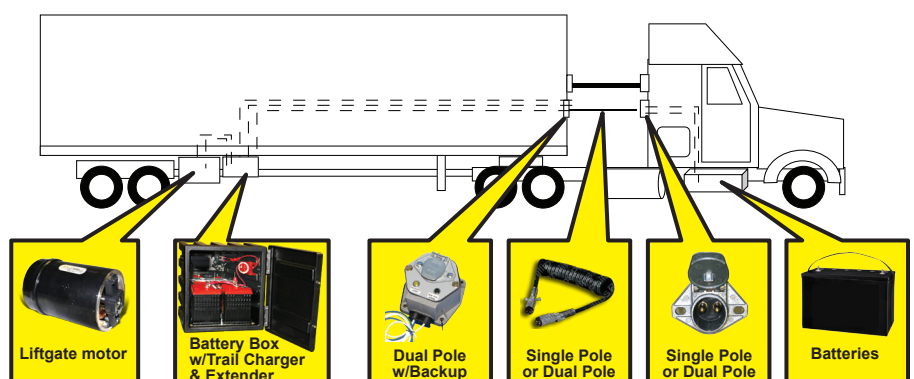

Trailer or Refrigerated