

M-99-41  
REV. A  
APRIL, 2000

# OPERATION MANUAL

# TUK-A-WAY<sup>®</sup>

## LIFT GATE SERIES

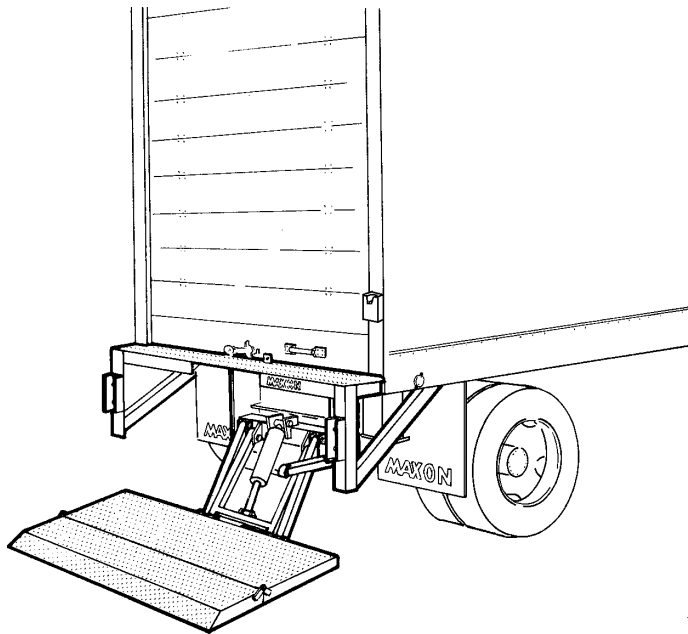

# 72-150 LMV

# TE-20 LMV

**MAXON<sup>®</sup>**  
LIFT CORP.

11921 Slauson Avenue.  
Santa Fe Springs, CA. 90670  
(800) 227-4116

# **MAXON<sup>®</sup>**

**LIFT CORP.**

**11921 Slauson Ave.  
Santa Fe Springs, CA. 90670**

---

## **CUSTOMER SERVICE:**

**TELEPHONE (562) 464-0099 TOLL FREE (800) 227-4116**

**FAX: (888) 771-7713**

**NOTE: Check with Customer Service for updated versions  
of Manuals on an annual basis.**

## **WARRANTY POLICY & PROCEDURE**

### **NEW LIFTGATE WARRANTY**

Term of Warranty: 2 Years from Date of In-Service

Type of Warranty: Full Parts and Labor

MAXON agrees to replace any components which are found to be defective during the first 2 years of service, and will reimburse for labor based on MAXON's Liftgate Warranty Flat Rate Labor Schedule. (Call MAXON Customer Service for a copy).

All claims for warranty must be received within 30 Days of the repair date, and include the following information:

1. Liftgate Model Number
2. Liftgate Serial Number
3. Detailed Description of Problem
4. Corrective Action Taken, and Date of Repair.
5. Parts used for Repair, Including MAXON Part Number(s).
6. MAXON R.M.A. # and/or Authorization # if applicable (see below).
7. Person contacted at MAXON if applicable.

All warranty repairs must be performed by an authorized MAXON warranty station. For major repairs, MAXON Customer Service must be notified and an "Authorization Number" obtained. Major repairs would generally be considered repairs made to the structural assembly of the liftgate and/or repairs not outlined in the MAXON Liftgate Warranty Flat Rate Schedule.

Major components (i.e. hydraulic pumps, cylinders, valves, or failed structural parts) must be returned, freight pre-paid, prior to the claim being processed. To ensure timely processing of these warranty claims, an R.M.A. (Returned Merchandise Authorization) number must be obtained from MAXON Customer Service prior to the return of any defective part. Defective Parts must be returned within 60 days of the claim date for consideration to:

**MAXON Lift Corp.**

**16205 Distribution Way, Cerritos, CA 90703**

**Attn: RMA#\_\_**

MAXON's warranty policy does not include the reimbursement for travel time, towing, vehicle rental, service calls, oil, batteries, defects due to misuse or abuse, or loss of income due to downtime. Fabrication of parts, which are available from MAXON, are also not covered.

MAXON's Flat Rate Labor Schedule takes into consideration the time required for diagnosis of a problem.

### **PURCHASE PART WARRANTY**

Term of Warranty: 1 Year from Date of Purchase

Type of Warranty: Part Replacement

MAXON will guarantee all returned genuine replacement parts upon receipt and inspection of parts and invoice.

# Table of Contents

WARNING .....	PAGE 4
LIFTGATE TERMINOLOGY .....	PAGE 5
DECALS .....	PAGE 6
POSITION OF LOAD AND OPERATOR .....	PAGE 7
OPERATION .....	PAGE 8
LOW VOLTAGE / THERMAL SWITCH (LVTS) .....	PAGE 10
FORKLIFT .....	PAGE 11

## WARNING

1. Read the **Operator's Manual** and understand it thoroughly before operating this unit.
2. Read the urgent warning decal on the side of the vehicle close to the unit before operating.
3. If decals are dirty, clean them. If decals are defaced or missing, replace them. **Free replacements** are available from the manufacturer. See information at the end of the Warnings !
4. Be aware that the safety and location of other people or objects should be considered before operation of this unit. Stand to one side of platform while operating this unit. Do not stand in a position that would put you in the path of any moving vehicles around you.
5. Do not stand under, or have any foreign object under the Platform when lowering. **Be sure that the lowering of the Platform and/or Flipover will miss your feet!**
6. Keep fingers, hands, arms, legs, and feet clear of moving parts when operating this unit.
7. If Platform is used as a ramp between vehicle and dock, DO NOT ALLOW ANY TRANSFER OF LOADS TO EXCEED THE RATED CAPACITY OF THIS UNIT!
8. Do not allow children to ride, play with, or operate this unit.
9. In the event of an emergency while operating the unit, release the toggle switch and the unit will stop immediately.
10. A properly installed Lift should operate smoothly and the only noise during the operation of this unit should be from the Pump Unit during the raising of the Platform. Any scraping, grating or audible indications of rough operation will need investigating. The cause will need resolving before any further deterioration of performance occurs.

Use only **Maxon Authorized Parts** for replacement. Replacement parts should be ordered from:

MAXON LIFT CORP. Parts Department  
11921 Slauson Ave., Santa Fe Springs, Ca. 90670  
Phone: (800) 227-4116

# LIFTGATE TERMINOLOGY

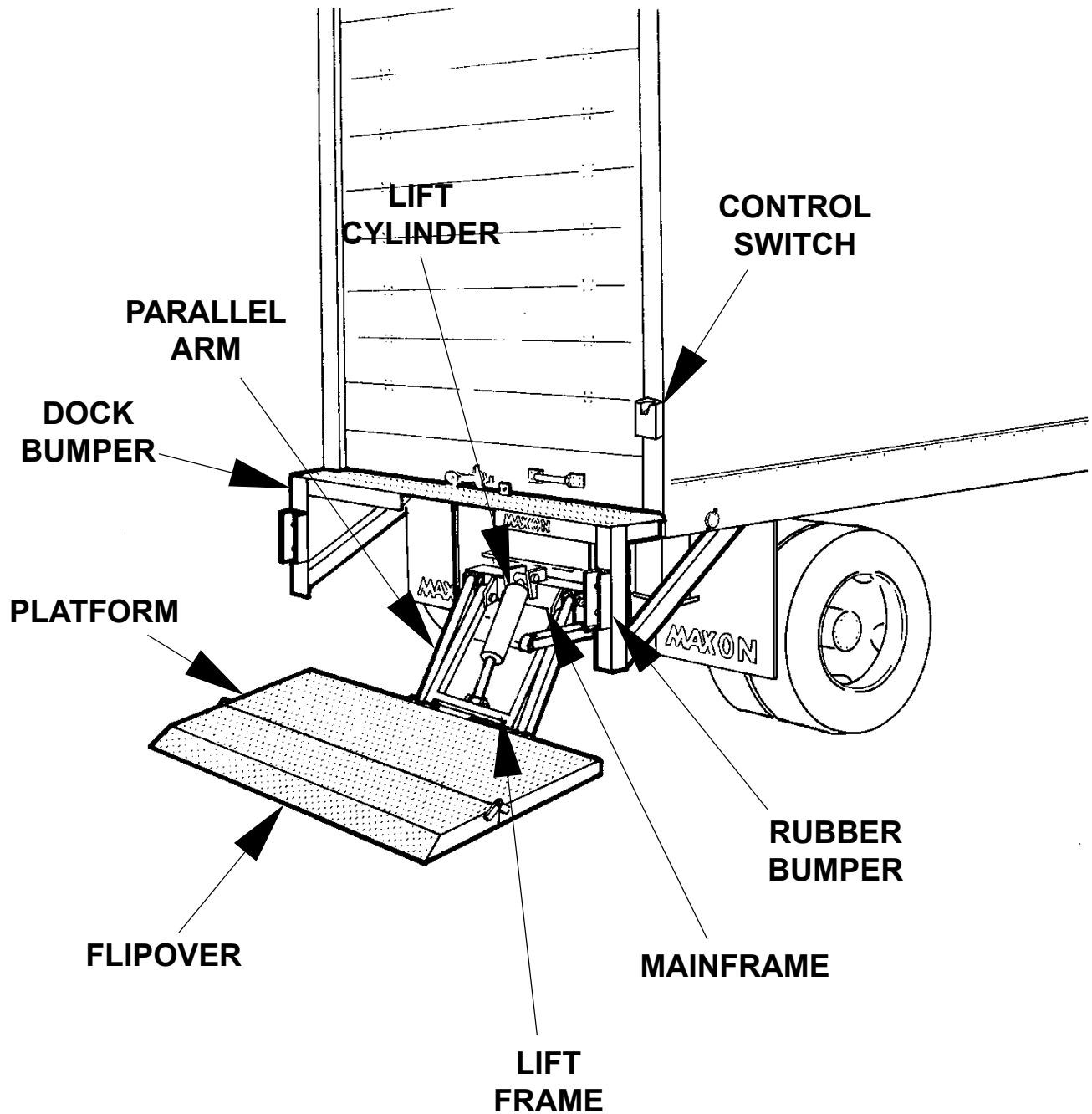

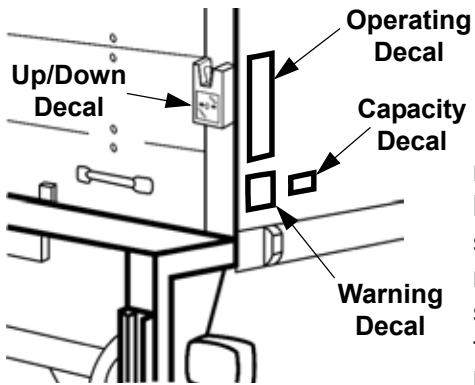

**Suggested Decal Locations**

**DECALS**

These Decals should be read and completely understood before operating the unit. They should also be kept clean and readable at all times. If any decal should become detached from the vehicle, or defaced, it must be replaced. Free replacements are available from: MAXON Lift Corp., Parts Department.

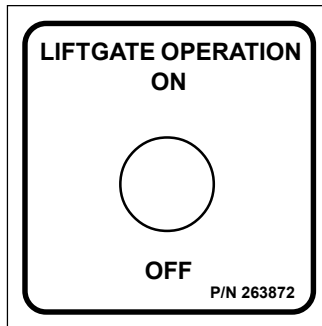
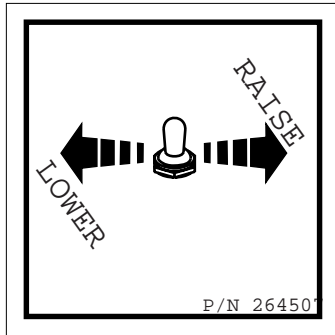

This Decal is for cab cut-off option and is located inside the Cab.

**WARNING**  
**READ CAREFULLY**

- Improper operation of this Lift can result in serious personal injury. Do not operate unless you have been properly instructed and have read, and are familiar with the operating instructions. If you do not have a copy of the instructions, please obtain them from your employer, distributor, or lessor, before you attempt to operate Lift.
- Be certain that the vehicle is properly and securely braked before using the Lift.
- Always inspect this Lift for maintenance or damage before using it. If there are signs of improper maintenance, damage to vital parts, or slippery Platform surface, do not use the Lift until these problems have been corrected.
- Do not overload the Lift. The load limit is based on evenly distributed cargo over the entire Platform surface. If you are using a pallet jack, be sure it can be maneuvered safely. Do not operate a forklift on the Platform or travel with the platform in an open position at any time.
- Load should be placed in a stable position close to the edge of the Platform nearest the truck. The heaviest portion of the load should never be placed beyond the center of the Platform away from the truck.
- Never allow yourself, a helper, or bystander to stand in a position where a falling load could land on either of you. Also do not allow any part of yours or your helper's body to be placed under, within, or around any portion of the moving liftgate, or its mechanisms, or in a position that would trap them between the platform and the ground or truck when the liftgate is operated.
- If a helper is riding the Platform with you, make sure you are both doing so safely and that you are not in danger of coming in contact with any moving or potentially moving obstacles. USE GOOD COMMON SENSE. If load appears to be unsafe, do not lift or lower it.

**MAXON LIFT CORP. PART NO. 264081**

**Operating Instructions**  
**TUK-A-WAY® Units**

**Depress handle & activate Toggle Switch to lower stowed liftgate.** 1  
This point must touch ground.

**Open Platform** 2

**Open Flipover** 3

**Activate toggle switch to Raise or Lower platform** 4

**To Tuck unit away, reverse steps 1,2,& 3.** 5

**MAXON**  
□ P/N 251867

**THE MAXIMUM CAPACITY OF THIS LIFT IS**  
**1500 LBS.**  
WHEN THE LOAD IS CENTERED ON THE LOAD CARRYING PLATFORM  
P/N 220386

**THE MAXIMUM CAPACITY OF THIS LIFT IS**  
**2000 LBS.**  
WHEN THE LOAD IS CENTERED ON THE LOAD CARRYING PLATFORM  
P/N 220387

## POSITION OF LOAD AND OPERATOR

All loads must be placed as close to the edge of the Platform nearest to the vehicle floor as possible, with the heaviest part of the load toward the vehicle. No part of any load should be allowed to extend over the edges of the Platform. Do not place unstable loads on the Platform. Do not allow any load to exceed the rated capacity for the unit. If standing on the Platform, do not allow your feet to protrude beyond the edges, this may cause serious bodily injury.

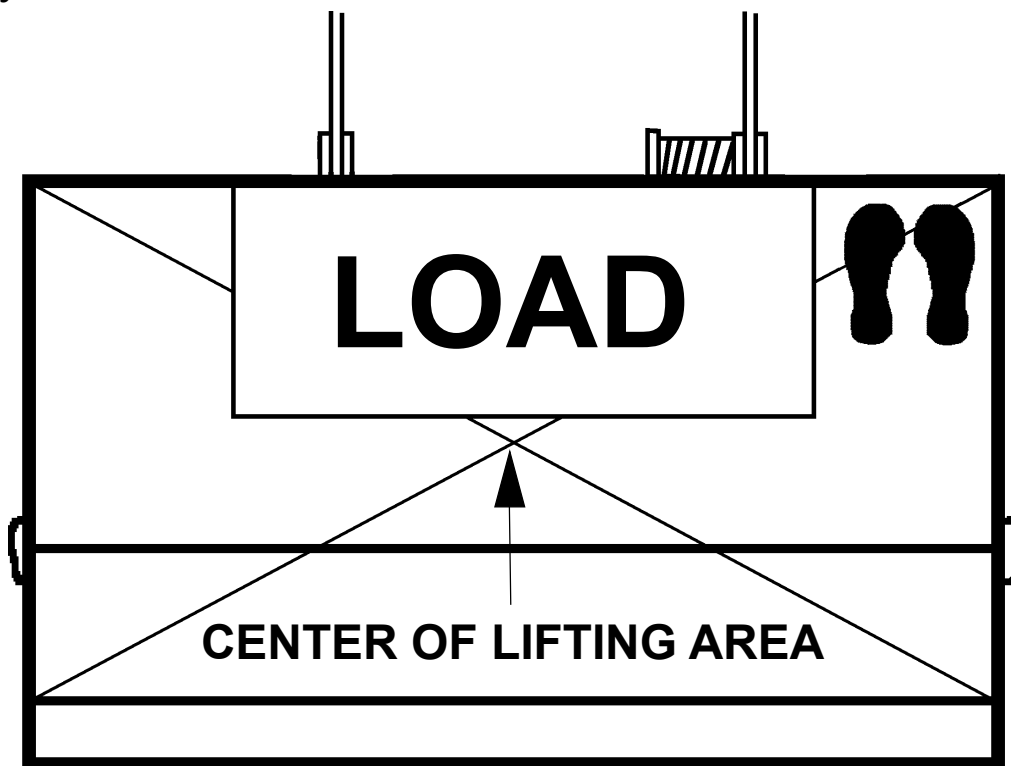

# OPERATION

**MAXON**<sup>®</sup>

11921 Slauson Ave. Santa Fe Springs, CA. 90670 (800) 227-4116 FAX (888) 771-7713

- 1.** If a locking device is installed, it must be unlocked before attempting to operate the unit.
- 2.** Standing clear of Platform, depress the Control Handle and activate the Toggle Switch to the "down" position. The Control Handle can be released after the Locking Hook clears the Platform. (Approx. 2" down from the "Stowed" position.)

When liftgate touches the ground, release the Toggle Switch.

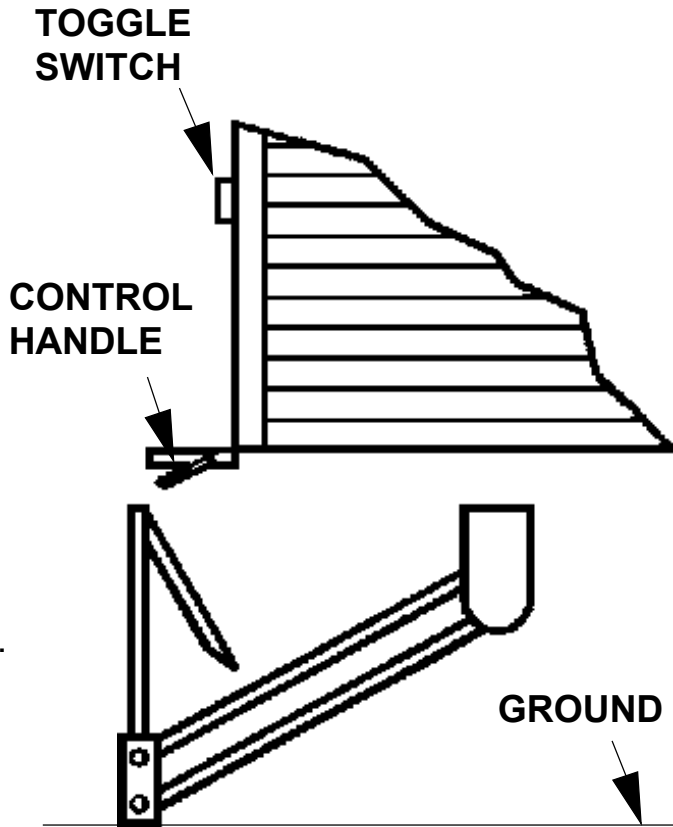

- 3.** Un-fold the platform.

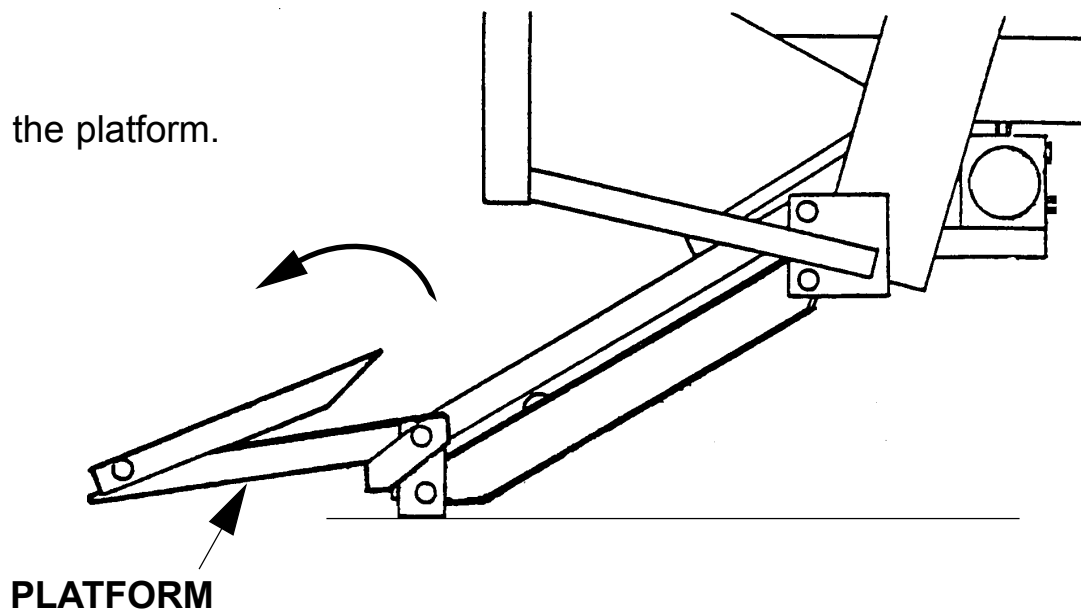



## OPERATION

4. Un-fold the flipover.

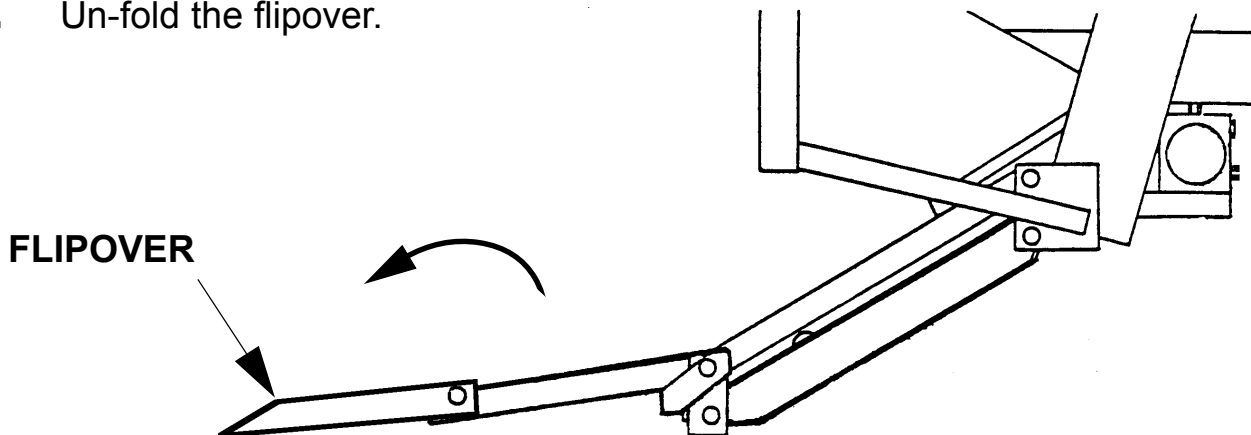

5. Raise or lower the liftgate by holding the Toggle Switch in the desired function. Once the platform reaches the bed height, or the ground, release the switch.

Should an emergency occur at any time during the operation of this unit, the platform can be stopped immediately by releasing the Toggle Switch.

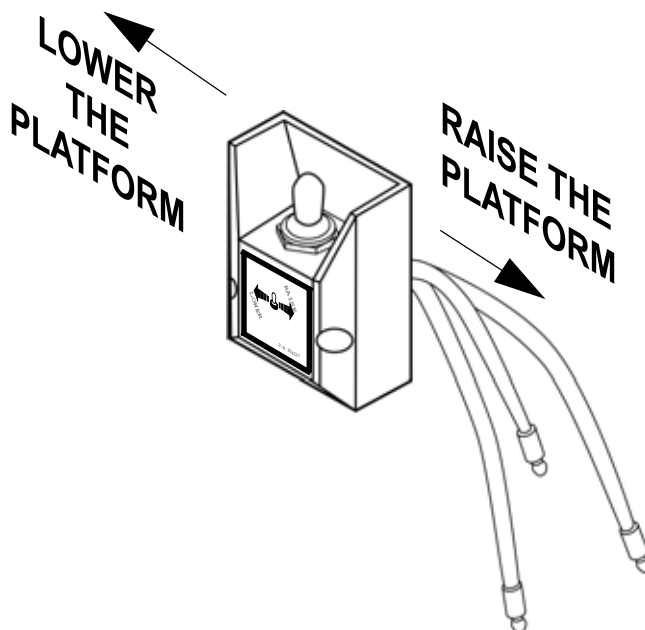

6. To fold the liftgate for transport, reverse steps 1 through 4.

**NOTE:** It will not be necessary to hold the control handle in an "up" position to raise the liftgate. The spring loaded Hook should snap and lock onto the platform for proper storage.

# LOW VOLTAGE / THERMAL SWITCH (LVTS) (IF EQUIPPED ON LIFTGATE)

This liftgate may be equipped with a system protection device called an LVTS. It is designed to shut down the liftgate if the motor temperature or battery voltage level reaches an unacceptable level. A decal (P/N 264776) positioned near the control switch will designate if the liftgate on the vehicle is so equipped. If this decal is not visible, check inside the pump box to determine if the device is attached, as shown in the illustration below.

The instructions below describe the operation of the LVTS. Read and understand these instructions thoroughly before operating this liftgate.

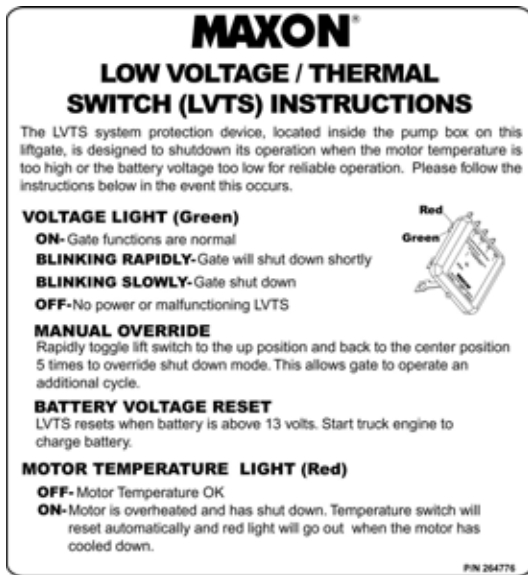

## Low Voltage / Thermal Switch Battery Reset

1. Green light is ON: normal voltage operation.
2. Green light is Blinking Slowly: gate will not operate due to Low Voltage disconnect. Start vehicle to re-charge battery
3. Green light is Blinking Rapidly: warning that low voltage condition is starting to occur.
4. Green light is OFF: indicates no power to device or LVTS is malfunctioning.
5. Low Voltage manual bypass can be used to raise liftgate a couple of times. Toggle switch to "up" position 5 times to activate override mode. The bypass mode will not work if red light is on due to Thermal Switch.

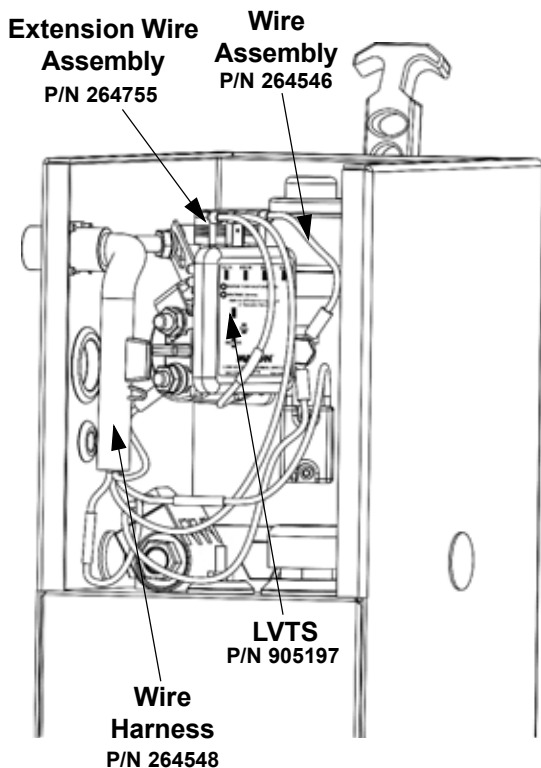

## Low Voltage / Thermal Switch Motor High-Temperature

1. Red light is OFF: normal motor temperature operation.
2. Red light is ON: gate will not operate when motor temperature is too high. Once motor cools down, Thermal Switch will automatically reset and allow continued gate operation.

**MAXON®**

11921 Slauson Ave. Santa Fe Springs, CA. 90670 (800) 227-4116 FAX (888) 771-7713

# FORKLIFT

**WARNING!! Keep Forklift Off of Platform!!!**

