

M-01-24
REV. C
AUGUST 2008

Maintenance Manual Contains:

- Warranty Information
- Warnings
- Service Time Chart
- Periodic Maintenance Checklist
- Service and Maintenance Instructions
- Decals
- Hydraulic & Electrical System Diagrams
- Troubleshooting

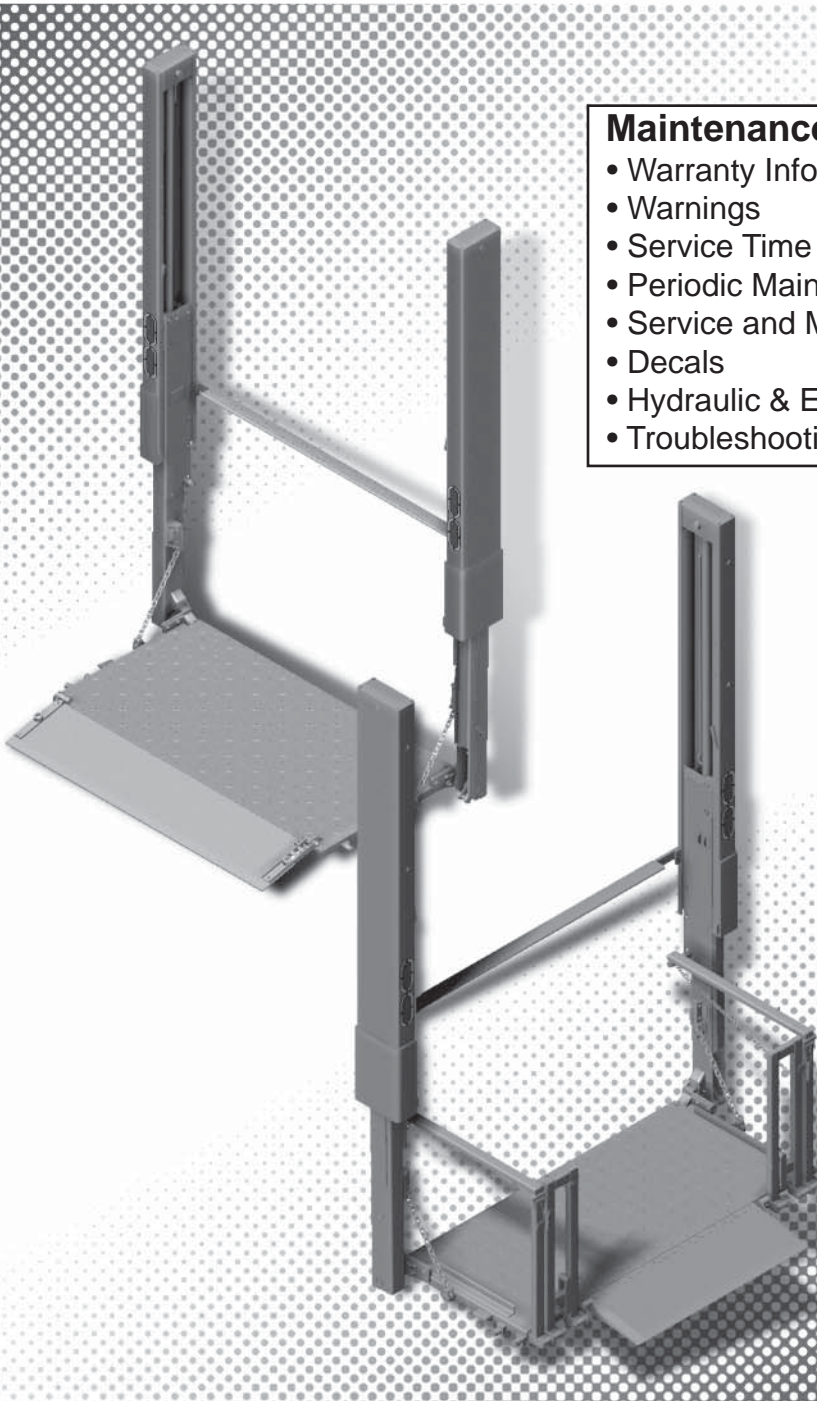

MAXON[®]
LIFT CORP.

BMR-A-ONE PIECE
BMR-A-CS
MAINTENANCE MANUAL

MAXON[®]

LIFT CORP.

11921 Slauson Ave.
Santa Fe Springs, CA. 90670

CUSTOMER SERVICE:

TELEPHONE (562) 464-0099 TOLL FREE (800) 227-4116

FAX: (888) 771-7713

NOTE: For latest version of all Manuals (and replacements), download the Manuals from Maxon's website at www.maxonlift.com.

WARRANTY/ RMA POLICY & PROCEDURE

LIFTGATE WARRANTY

Type of Warranty: Full Parts and Labor
Term of Warranty: Standard Liftgates - 2 years from ship date or 6,000 cycles
Premium Liftgates - 2 years from ship date or 10,000 cycles

This warranty shall not apply unless the product is installed, operated and maintained in accordance with MAXON Lift's specifications as set forth in MAXON Lift's Installation, Operation and Maintenance manuals. This warranty does not cover normal wear, maintenance or adjustments, damage or malfunction caused by improper handling, installation, abuse, misuse, negligence, or carelessness of operation. In addition, this warranty does not cover equipment that has had unauthorized modifications or alterations made to the product.

MAXON agrees to replace any components which are found to be defective during the first 2 years of service, and will reimburse for labor based on MAXON's Liftgate Warranty Flat Rate Schedule. (Copy of the Flat Rate is available at www.maxonlift.com.)

All warranty repairs must be performed by an authorized MAXON warranty facility. For any repairs that may exceed \$500, including parts and labor, MAXON's Technical Service Department must be notified and an "Authorization Number" obtained.

All claims for warranty must be received within 30 Days of the repair date, and include the following information:

1. Liftgate Model Number and Serial Number
2. The End User must be referenced on the claim
3. Detailed Description of Problem
4. Corrective Action Taken, and Date of Repair
5. Parts used for Repair, Including MAXON Part Number(s)
6. MAXON R.M.A. # and/or Authorization # if applicable (see below)
7. Person contacted at MAXON if applicable
8. Claim must show detailed information i.e. Labor rate and hours of work performed

Warranty claims can also be placed online at www.maxonlift.com. Online claims will be given priority processing.

All claims for warranty will be denied if paperwork has not been received or claim submitted via Maxon website for processing by MAXON's Warranty Department within 30 days of repair date.

All components may be subject to return for inspection, prior to the claim being processed. MAXON products may not be returned without prior written approval from MAXON's Technical Service Department. Returns must be accompanied by a copy of the original invoice or reference with original invoice number and are subject to a credit deduction to cover handling charges and any necessary reconditioning costs. **Unauthorized returns will be refused and will become the responsibility of the returnee.**

Any goods being returned to MAXON Lift must be pre-approved for return, and have the R.M.A. number written on the outside of the package in plain view, and returned freight prepaid. All returns are subject to a 15% handling charge if not accompanied by a detailed packing list. Returned parts are subject to no credit and returned back to the customer. Defective parts requested for return must be returned within 30 days of the claim date for consideration to:

MAXON Lift Corp.
10321 Greenleaf Ave., Santa Fe Springs, CA 90670
Attn: RMA# _____

MAXON's warranty policy does not include the reimbursement for travel time, towing, vehicle rental, service calls, oil, batteries or loss of income due to downtime. Fabrication or use of non Maxon parts, which are available from MAXON, are also not covered.

MAXON's Flat Rate Labor Schedule takes into consideration the time required for diagnosis of a problem.

All Liftgates returned are subject to inspection and a 15% restocking fee. Any returned Liftgates or components that have been installed or not returned in new condition will be subject to an additional reworking charge, which will be based upon the labor and material cost required to return the Liftgate or component to new condition.

PURCHASE PART WARRANTY

Term of Warranty: 1 Year from Date of Purchase.

Type of Warranty: Part replacement only. MAXON will guarantee all returned genuine MAXON replacement parts upon receipt and inspection of parts and original invoice.

All warranty replacements parts will be sent out via ground freight. If a rush shipment is requested, all freight charges will be billed to the requesting party.

TABLE OF CONTENTS

WARNINGS	6
SAFETY INSTRUCTIONS	6
PERIODIC MAINTENANCE	8
DECAL - WELDING CAUTION	8
DECALS	10
MAXON BMR-A LIFTGATE	12
PREVENTATIVE MAINTENANCE CHECKLIST	12
PERIODIC MAINTENANCE CHECKLIST.....	13
CHECKING HYDRAULIC FLUID	14
CHANGING HYDRAULIC FLUID	16
BLEEDING HYDRAULIC SYSTEM.....	17
PLATFORM FOLDING AND UNFOLDING SPEED ADJUSTMENT	18
REPLACING PARTS	19
CLOSING CYLINDER REPLACEMENT	19
LIFTING CYLINDER REPLACEMENT	20
RUNNER REPLACEMENT	23
HYDRAULIC SYSTEM DIAGRAMS	36
PUMP & MOTOR SOLENOID OPERATION.....	36
HYDRAULIC SCHEMATIC, SINGLE PUMP GRAVITY DOWN	37
HYDRAULIC SCHEMATIC, DUAL PUMP GRAVITY DOWN	38
HYDRAULIC SCHEMATIC, SINGLE PUMP POWER DOWN	39
HYDRAULIC SCHEMATIC, DUAL PUMP POWER DOWN	40
ELECTRICAL SYSTEM DIAGRAMS	41
WIRING SCHEMATIC, GRAVITY DOWN	41
SINGLE PUMP BOX, GRAVITY DOWN.....	42

DUAL PUMP BOX, GRAVITY DOWN	43
WIRING SCHEMATIC, POWER DOWN	44
SINGLE PUMP BOX, POWER DOWN	45
DUAL PUMP BOX, POWER DOWN	46
WIRING HARNESS CONNECTOR IDENTIFICATION	47
TROUBLESHOOTING	48
PLATFORM WILL NOT RAISE, MOTOR WILL NOT RUN.....	48
PLATFORM WILL NOT PICK UP RATED CAPACITY	49
PLATFORM RAISES HALFWAY & STOPS.....	50
PLATFORM RAISES AND LOWERS UNEVENLY	52
PLATFORM WILL NOT FOLD.....	53
PLATFORM WILL NOT UNFOLD.....	55
PUMP ASSEMBLY PRESSURE SETTING	57
RELIEF VALVE PRESSURE SETTING	58
TROUBLESHOOTING - GRAVITY DOWN.....	59
PLATFORM WILL NOT RAISE, MOTOR RUNS	59
PLATFORM WILL NOT LOWER	60
PLATFORM LOWERS SLOWLY	61
TROUBLESHOOTING - POWER DOWN.....	62
PLATFORM WILL NOT RAISE, MOTOR RUNS	62
PLATFORM WILL NOT LOWER	63
PLATFORM LOWERS SLOWLY	64

Comply with the following **WARNINGS** and **SAFETY INSTRUCTIONS** while maintaining Liftgates. See Operation Manual for operating safety requirements.

WARNING

- Do not stand, or allow obstructions, under the platform when lowering the Liftgate. **Be sure your feet are clear of the Liftgate.**
- **Keep fingers, hands, arms, legs, and feet clear of moving Liftgate parts (and platform edges) when operating the Liftgate.**
- **Correctly stow platform when not in use. Extended platforms could create a hazard for people and vehicles passing by.**
- **Disconnect Liftgate power cable from battery** before repairing or servicing Liftgate.
- If it is necessary to stand on the platform while maintaining the Liftgate, keep your feet and any objects clear of the inboard edge of the platform. Your feet or objects on the platform can become trapped between the platform and the Liftgate extension plate.
- Recommended practices for welding on steel parts are contained in the current **AWS (American Welding Society) D1.1 Structural Welding Code - Steel**. Damage to Liftgate and/or vehicle, and personal injury could result from welds that are done incorrectly.
- Recommended practices for welding on aluminum parts are contained in the current **AWS (American Welding Society) D2.1 Structural Welding Code - Aluminum**. Damage to Liftgate and/or vehicle, and personal injury could result from welds that are done incorrectly.

SAFETY INSTRUCTIONS

- Read and understand the instructions in this **Maintenance Manual** before performing maintenance on the Liftgate.
- Before operating the Liftgate, read and understand the operating instructions in **Operation Manual**.
- Comply with all **WARNING** and instruction decals attached to the Liftgate.
- Keep decals clean and legible. If decals are illegible or missing, replace them. Free replacement decals are available from **Maxon Customer Service**.
- Consider the safety and location of bystanders and location of nearby objects when operating the Liftgate. Stand to one side of the platform while operating the Liftgate
- Do not allow untrained persons to operate the Liftgate.
- Wear appropriate safety equipment such as protective eyeglasses, faceshield and clothing while performing maintenance on the Liftgate and handling the battery. Debris from drilling and contact with battery acid may injure unprotected eyes and skin.
- Be careful working by an automotive type battery. Make sure the work area is well ventilated and there are no flames or sparks near the battery. Never lay objects on the battery that can short the terminals together. If battery acid gets in your eyes, immediately seek first aid. If acid gets on your skin, immediately wash it off with soap and water.

MAXON[®]

11921 Slauson Ave. Santa Fe Springs, CA. 90670 (800) 227-4116 FAX (888) 771-7713

- If an emergency situation arises (vehicle or Liftgate) while operating the Liftgate, release the control switch to stop the Liftgate.
- A correctly installed Liftgate operates smoothly and reasonably quiet. The only noticeable noise during operation comes from the power unit while the platform is raised. Listen for scraping, grating and binding noises and correct the problem before continuing to operate Liftgate.
- Use only **Maxon Authorized Parts** for replacement parts. Provide Liftgate model and serial number information with your parts order. Order replacement parts from:

MAXON LIFT CORP. Customer Service
11921 Slauson Ave., Santa Fe Springs, CA 90670

Online: www.maxonlift.com

Express Parts Ordering: Phone (800) 227-4116 ext. 4345

Email: Ask your Customer Service representative

PERIODIC MAINTENANCE

DECAL - WELDING CAUTION

CAUTION

Comply with welding CAUTION decals on Liftgate runners.

NOTE: See following pages to find the other decals on Liftgate.

! CAUTION !

When performing any electrical welding operations to the structure of this Lift, be careful to connect the ground lead to the Liftgate component being welded (e.g. runner assembly, column assembly, platform assembly), and as close to the area being welded as possible.

Because the separate assemblies on the BMR series Lifts are insulated by self-lubricated bearings, failure to do so will cause severe damage to electrical components and metal parts.

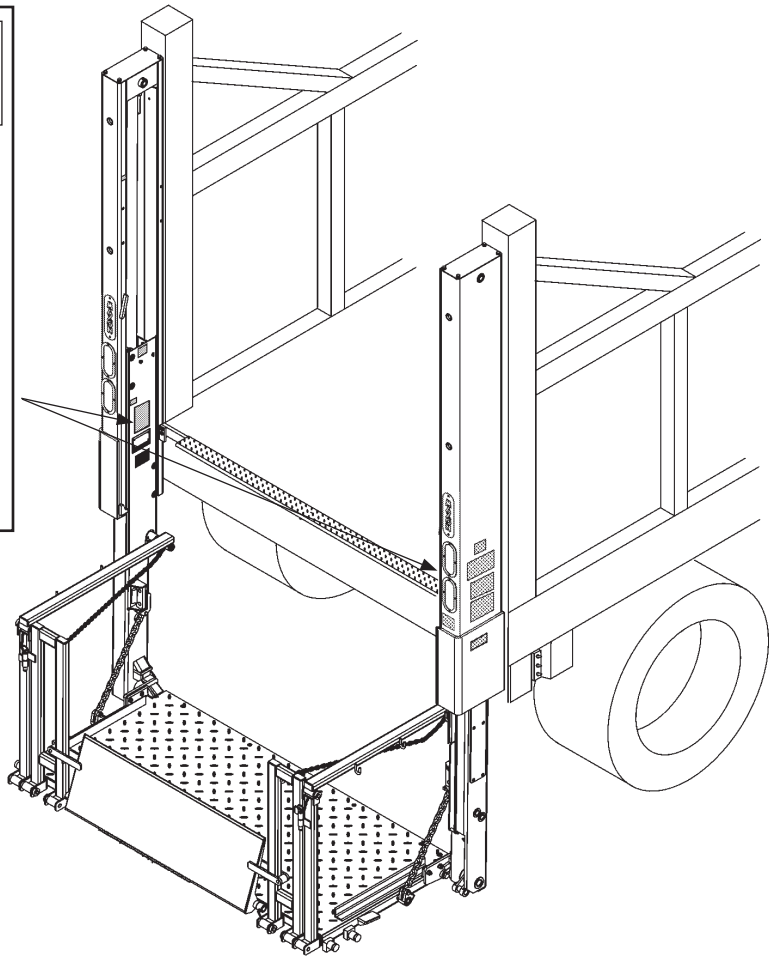

FIG. 8-1

MAXON[®]

11921 Slauson Ave. Santa Fe Springs, CA. 90670 (800) 227-4116 FAX (888) 771-7713

THIS PAGE INTENTIONALLY LEFT BLANK

PERIODIC MAINTENANCE DECALS



CAUTION DECAL (2 PLACES)
P/N 266508-01

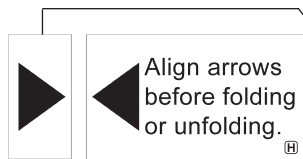

DECAL "H"

SERIAL PLATE

PAINT DECAL (BMR-A, 2 PLACES)
P/N 267338-01

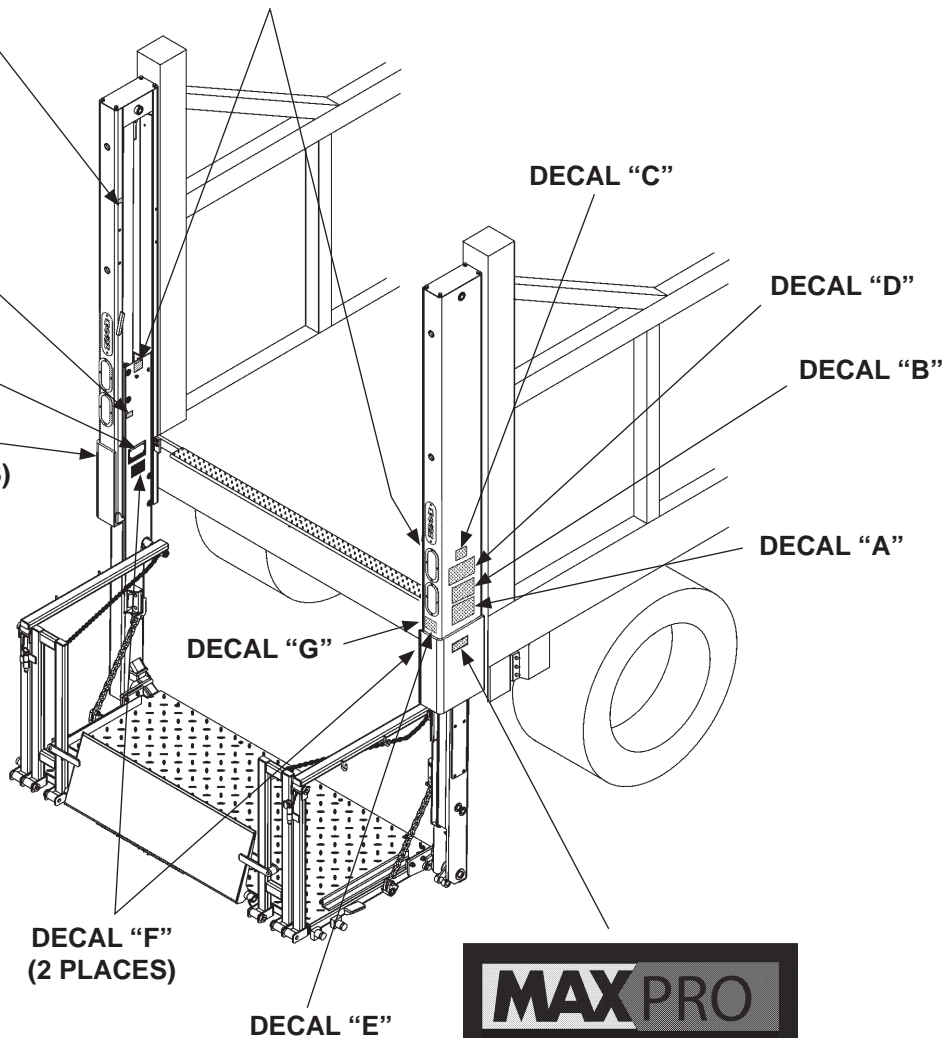

PAINT DECAL (BMR-A, 2 PLACES)
P/N 267338-01

MAXON[®]
11921 Slauson Ave. Santa Fe Springs, CA. 90670 (800) 227-4116 FAX (888) 771-7713

FIG. 10-1

SAFETY INSTRUCTIONS

Read all decals and operation manual before operating liftgate.

1. Do not use liftgate unless you have been properly instructed and have read, and are familiar with, the operating instructions.
2. Be certain vehicle is properly and securely braked before using the liftgate.
3. Always inspect this liftgate for maintenance or damage before using it. Do not use liftgate if it shows any sign of damage or improper maintenance.
4. Do not overload
5. Make certain the area in which the platform will open and close is clear before opening or closing the platform.
6. Make certain platform area, including the area in which loads may fall from platform, is clear before and at all times during operation of liftgate.
7. This liftgate is intended for loading and unloading of cargo only. Do not use this liftgate for anything but its intended use.

(A)

WARNING

Read this information carefully.

- Improper operation of this Liftgate can result in serious personal injury. If you do not have a copy of the operating instructions, please obtain them from your employer, distributor, or lessor before you attempt to operate Liftgate.
- If there are signs of improper maintenance, damage to vital parts, or slippery platform surface, do not use the Liftgate until these problems have been corrected.
- If you are using a pallet jack, be sure it can be maneuvered safely.
- Do not operate a forklift on the platform.
- Do not allow any part of yours or your helper's body to be placed under, within, or around any portion of the moving Liftgate, or its mechanisms, or in a position that would trap them between the platform and the ground or truck when the Liftgate is operated.
- If a helper is riding the platform with you, make sure you are both doing so safely and that you are not in danger of coming in contact with any moving or potentially moving obstacles.
- **USE GOOD COMMON SENSE.**
- If load appears to be unsafe, do not lift or lower it.

For a free copy of other manuals that pertain to this model Liftgate, please visit our website at www.maxonlift.com or call Customer Service at (800) 227-4116.

(B)

THE MAXIMUM CAPACITY OF THIS LIFT IS

POUNDS

WHEN THE LOAD IS CENTERED ON THE LOAD CARRYING PLATFORM

(C)

(REFER TO TABLE 11-1)

WARNING



Liftgate hazards can result in crushing or falling.

Keep hands and feet clear of pinch points.

If riding liftgate, make sure load is stable and footing is solid.

(D)

Read and understand all instructions and WARNINGS before use.

CAUTION

Always stand clear of platform area.

(E)

CAUTION

Do not grease columns.

(F)

UP ↑

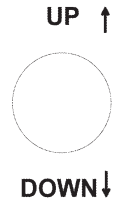

DOWN ↓

(G)

Align arrows before folding or unfolding.

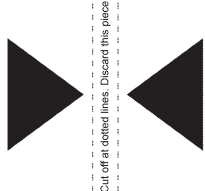

(H)

DECAL SHEET
FIG. 11-1

Model	DECAL SHEET P/N	DECAL "C"
BMRA-35 & BMRA35-CS	268309-01	3500 POUNDS
BMRA-44 & BMRA44-CS	268309-02	4400 POUNDS

DECAL SHEET PART NUMBERS
TABLE 11-1

FIG. 11-1

PERIODIC MAINTENANCE

MAXON BMR-A LIFTGATE

PREVENTATIVE MAINTENANCE CHECKLIST

PM Interval: 3 Months

Date: ___ / ___ / ___

Equipment: _____

W/O # _____

Location: _____

Mechanic: _____

Serial # _____

Model # _____

Check Appropriate Box. " "

MAXON 1 st , 2 nd and 3 rd Quarter Liftgate PM Procedures				
Satisfactory	Repair Required	Corrected	1	Verify if the Quarterly or Annual PM is due by checking the PM sticker on the roadside Liftgate column
Satisfactory	Repair Required	Corrected	2	Check for oil leaks at: cylinders, fittings, hoses, valves, oil filter and fittings inside of pump box
Satisfactory	Repair Required	Corrected	3	Check for damage: bent ramps, platform, column, runners and hydraulic tubes
Satisfactory	Repair Required	Corrected	4	Check for loose or missing nuts, bolts, covers, roll pins, screws and pins
Satisfactory	Repair Required	Corrected	5	Check for cracked welds at: columns, runners, platform, chain arms, pump box and door frame
Satisfactory	Repair Required	Corrected	6	Check platform lowering speed: Range is 15-25 seconds. Check "D" valves for proper operation
Satisfactory	Repair Required	Corrected	7	Check platform pins and couplers. Check roller assemblies
Satisfactory	Repair Required	Corrected	8	Check platform raising speed: Range is 20-40 seconds
Satisfactory	Repair Required	Corrected	9	Check open and close speed: Range is 4-7 seconds in either direction. Adjust if necessary
Satisfactory	Repair Required	Corrected	10	Check switches, circuit breaker and wiring connections at the gate as well as inside pump box. Also check ground straps
Satisfactory	Repair Required	Corrected	11	Check the gear pump for unusual noise. i.e. squealing or extreme RPM output
Satisfactory	Repair Required	Corrected	12	Checking Oil Level: gravity down with the Liftgate open and on the ground the sight glass should be at half level. Power down open Liftgate and raise to bed height the sight glass should be at half level. Check for contamination, change if needed
Satisfactory	Repair Required	Corrected	13	Check batteries: load test, corrosion, cables, hold downs and water level
Satisfactory	Repair Required	Corrected	14	Dual pump units: Please switch the selector switch to opposite assembly at each PM
Satisfactory	Repair Required	Corrected	15	Check chains for twisting
Satisfactory	Repair Required	Corrected	16	Check operation of cart stop ramps
Satisfactory	Repair Required	Corrected	17	Check all charging and ground cable connections
Satisfactory	Repair Required	Corrected	18	Complete a new PM sticker and install it on the roadside column of the Liftgate. The next PM date is 3 months from the completed PM date. Indicate on the PM sticker if 1 st , 2 nd , 3 rd or 4 th PM

MAXON 4 th Liftgate PM. Note: Includes steps 1-18				
Satisfactory	Repair Required	Corrected	19	Replace spin on filter in pump box. Change hydraulic fluid
Satisfactory	Repair Required	Corrected	20	Inspect wear on slide pads. See if shimming is required

For more detailed information, please refer to the product maintenance manuals. Use only genuine Maxon replacement parts for all repairs.

TABLE 12-1

PERIODIC MAINTENANCE CHECKLIST

WARNING

Never operate the Liftgate with parts loose or missing.

NOTE: Photocopy the PM CHECKLIST on the preceding page to help keep track of periodic maintenance on the Liftgate. Keep completed form with maintenance records.

Annually

Change spin-on oil filter. Visually check the entire Liftgate for excessively worn parts and broken welds, especially the hinge pins. See **Parts Manual** for replacement parts. Also, do the **Semi-annual** and **Quarterly Maintenance** checks.

Semi-annually

Visually check the platform hinge pins for excessive wear and broken welds. See **Parts Manual** for replacement parts. Also, do the **Quarterly Maintenance** checks.

Quarterly

Check the hydraulic fluid level in the pump reservoir. Refer to the **CHECKING HYDRAULIC FLUID** procedure in the **PERIODIC MAINTENANCE** section.

- If hydraulic fluid appears contaminated, refer to the **CHANGING HYDRAULIC FLUID** procedure on following page.
- Keep track of the grade of hydraulic fluid in the pump reservoir. Never mix two different grades of fluid.
- Check hoses and fittings for chaffing and fluid leaks. Replace if necessary.
- Check electrical wiring for chaffing and make sure wiring connections are tight and free of corrosion. **MAXON** recommends using dielectric grease on all electrical connections.
- Check that all **WARNING** and **instruction decals** are in place and legible.
- Check that all roll pins are in place and protrude evenly from both sides of hinge pin collar. Replace roll pins if necessary.
- Check each end of the two platform chains to make sure they are fastened properly.
- Check for worn out links on each of the two platform chains.
- Grease zerkl fittings on two lower pivot points.

CAUTION

Damaged cylinder seals and contaminated hydraulic fluid can result from painting the polished portion of the cylinder rod. To prevent damage, protect the exposed polished portion of the cylinder rod while painting.

- Check for rust and oily surfaces on Liftgate. If there is rust or oil on the Liftgate, clean it off. Touch up the paint where bare metal is showing.

PERIODIC MAINTENANCE

CHECKING HYDRAULIC FLUID

CAUTION

Keep dirt, water and other contaminants from entering the hydraulic system. Before opening the hydraulic fluid reservoir filler cap, drain plug and hydraulic lines, clean up contaminants that can get in the openings. Also, protect the openings from accidental contamination.

NOTE: Use correct grade of hydraulic fluid for your location.

+50 to +120 Degrees F - Grade ISO 32

Below + 70 Degrees F - Grade ISO 15 or MIL-H-5606

See **TABLES 15-1 and 15-2** for recommended brands.

NOTE: If the hydraulic fluid in the reservoir is contaminated, do the **CHANGING HYDRAULIC FLUID** procedure in this section.

GRAVITY DOWN POWER UNIT

1. For a gravity down power unit, open the platform and lower it to the ground.
2. Check if the sight glass on the pump cover is half full of hydraulic fluid (**FIG. 14-1**).
3. If needed, add fluid to the reservoir as follows. Open the pump cover and remove filler cap (**FIG. 14-2**). Add hydraulic fluid to reservoir until the sight glass looks half full (**FIG. 14-1**). Re-install filler cap (**FIG. 14-2**).

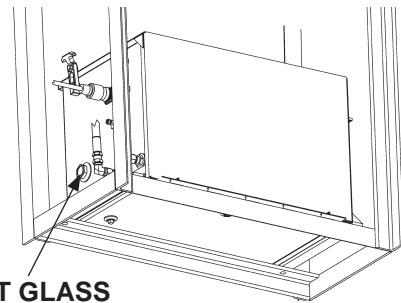

CHECKING HYDRAULIC FLUID LEVEL
FIG. 14-1

POWER DOWN POWER UNIT

1. For a power down power unit, open the platform and raise it to vehicle bed height.
2. Check if the sight glass on the pump cover is half full of hydraulic fluid (**FIG. 14-1**).
3. If needed, add fluid to the reservoir as follows. Open the pump cover and remove filler cap (**FIG. 14-2**). Add hydraulic fluid to reservoir until the sight glass looks half full (**FIG. 14-1**). Re-install filler cap (**FIG. 14-2**).

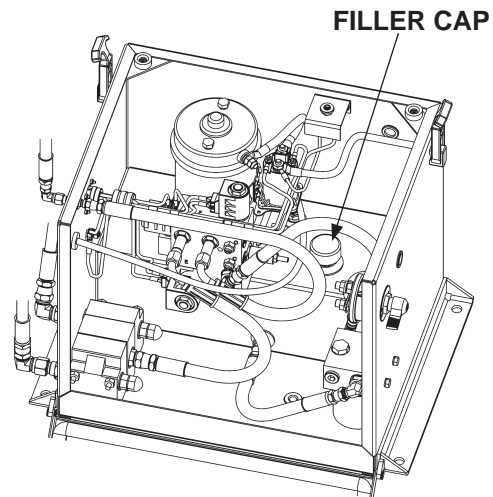

GRAVITY DOWN POWER UNIT
FIG. 14-2

ISO 32 HYDRAULIC OIL	
RECOMMENDED BRANDS	PART NUMBER
AMSOIL	AWH-05
CHEVRON	HIPERSYN 32
KENDALL	GOLDEN MV
SHELL	TELLUS T-32
EXXON	UNIVIS N-32
MOBIL	DTE-13M, DTE-24, HYDRAULIC OIL-13

TABLE 15-1

ISO 15 OR MIL-H-5606 HYDRAULIC OIL	
RECOMMENDED BRANDS	PART NUMBER
AMSOIL	AWF-05
CHEVRON	FLUID A, AW-MV-15
KENDALL	GLACIAL BLU
SHELL	TELLUS T-15
EXXON	UNIVIS HVI-13
MOBIL	DTE-11M
ROSEMEAD	THS FLUID 17111

TABLE 15-2

PERIODIC MAINTENANCE CHANGING HYDRAULIC FLUID

CAUTION

Keep dirt, water and other contaminants from entering the hydraulic system. Before opening the hydraulic fluid reservoir filler cap, drain plug and hydraulic lines, clean up contaminants that can get in the openings. Also, protect the openings from accidental contamination.

NOTE: Use correct grade of hydraulic fluid for your location.

+50 to +120 Degrees F - Grade ISO 32

Below + 70 Degrees F - Grade ISO 15 or MIL-H-5606

See **TABLES 15-1 and 15-2** for recommended brands.

GRAVITY DOWN LIFTGATES

1. Place empty 5 gallon bucket under drain plug.
2. Open and lower platform. Remove the drain plug (**FIG. 16-1**). Drain hydraulic fluid from system. Reinstall drain plug.
3. Remove filler cap (**FIG. 16-2**). Refill reservoir until sight glass (**FIG. 16-1**) is half full.
4. Reinstall filler cap (**FIG. 16-2**).

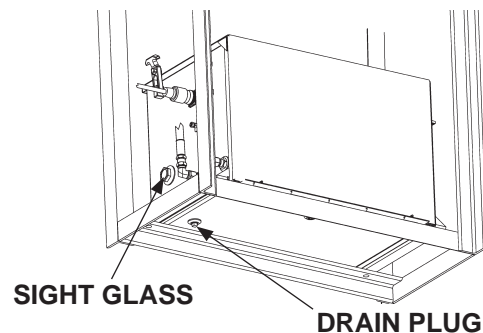

FIG. 16-1

POWER DOWN LIFTGATES

1. Place empty 5 gallon bucket under drain plug.
2. Open and raise platform to vehicle bed height. Remove the drain plug (**FIG. 16-1**).
3. Disconnect the white wire (**FIG. 16-2**) from motor solenoid. Lower the platform while draining hydraulic fluid from system. Reinstall drain plug. Reconnect the white wire to motor solenoid.
4. Remove filler cap (**FIG. 16-2**). Refill reservoir until sight glass (**FIG. 16-1**) is half full.
5. Raise platform to vehicle bed height. Check hydraulic fluid again and, if needed, add more hydraulic fluid until sight glass (**FIG. 15-2**) is half full.
6. Reinstall filler cap (**FIG. 16-2**).

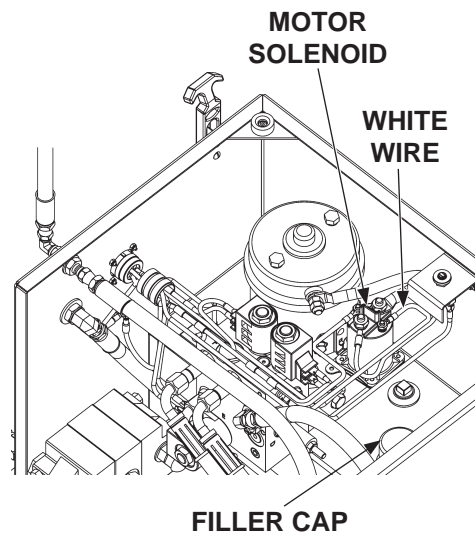

FIG. 16-2

BLEEDING HYDRAULIC SYSTEM

NOTE: Perform this procedure at a place where Liftgate platform can be lowered to lowest point of travel. Get a helper to operate Liftgate control switch.

1. Use **UP/DOWN** toggle switch to lower the opened platform to the ground.
2. Loosen, but do not disconnect, the cylinder line fitting from the pressure compensated flow control valve (**FIG. 17-1**) on top of both cylinders.

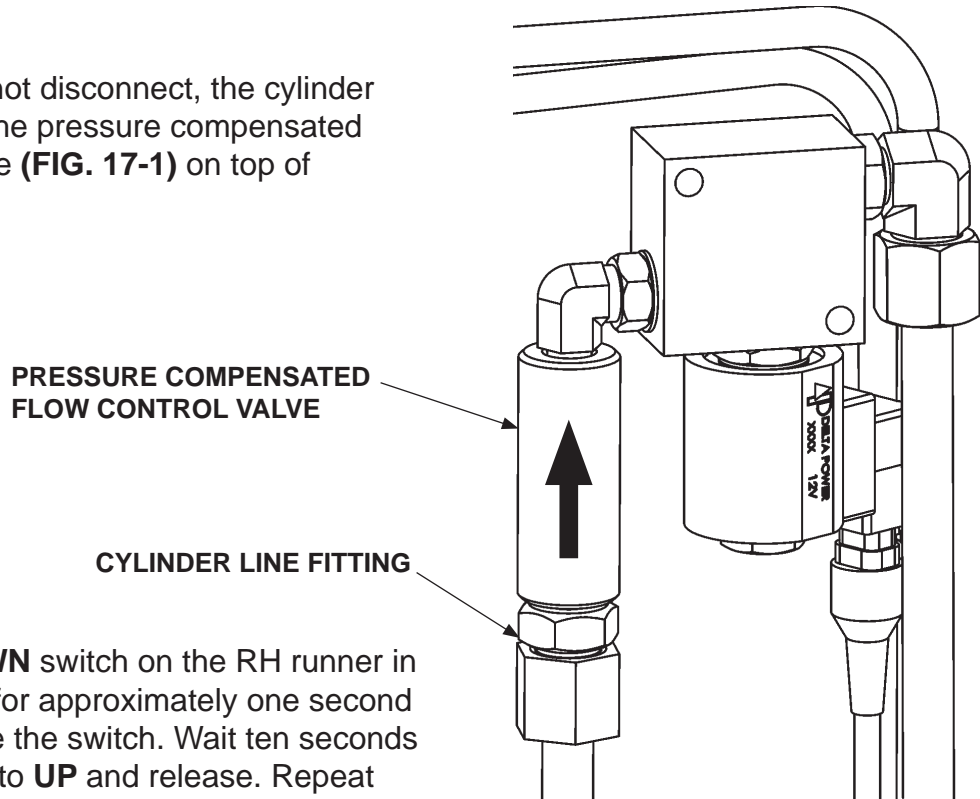

FIG. 17-1

3. Set the **UP/DOWN** switch on the RH runner in the **UP** position for approximately one second and then release the switch. Wait ten seconds and then switch to **UP** and release. Repeat this step until there is no air bubbling from the loosened line fittings.
4. Tighten cylinder line fitting to pressure compensated flow control valve (**FIG. 17-1**).
5. Use **UP/DOWN** toggle switch to raise and lower the platform to make sure the Liftgate operates correctly.

PERIODIC MAINTENANCE

PLATFORM FOLDING AND UNFOLDING SPEED ADJUSTMENT

1. The speed settings for the closing cylinder are regulated by the pressure relief needle valves located on the pump manifold (**FIG. 18-1**). One valve is marked “O” (open platform) and the other is marked “C” (close platform).
2. To decrease platform opening speed, turn opener valve adjustment (**FIG. 18-1**) clockwise. To increase platform opening speed, turn opener valve adjustment (**FIG. 18-1**) counter-clockwise.
3. To increase platform closing speed, turn closer valve adjustment (**FIG. 18-1**) clockwise. To decrease platform closing speed, turn closer valve adjustment (**FIG. 18-1**) counter-clockwise.

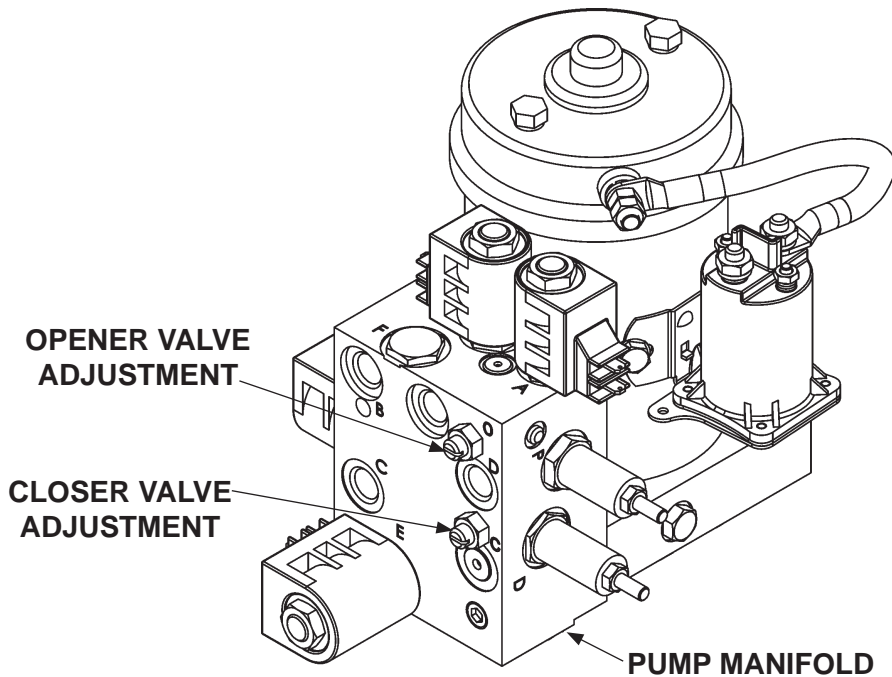

**TYPICAL PUMP OPENER AND
CLOSER ADJUSTMENTS
(POWER DOWN VERSION SHOWN)**

FIG. 18-1

MAXON[®]

11921 Slauson Ave. Santa Fe Springs, CA. 90670 (800) 227-4116 FAX (888) 771-7713

REPLACING PARTS CLOSING CYLINDER REPLACEMENT

1. **UNFOLD** the platform. Lower the platform (**DOWN**) to comfortable height for work. Upper pin must be lower than the bottom of the column (**see FIG. 19-1**).
2. Disconnect the hydraulic hose from lower end of cylinder (**FIG. 19-2**). Plug hose to prevent spills.
3. Remove the lower roll pin from inside coupling (**FIG. 19-2**) and then remove lower pin.
4. Remove the upper roll pin (**FIG. 19-2**) from the runner and then remove the upper pin.
5. Remove cylinder from runner (**FIG. 19-2**).
6. Place replacement cylinder in the correct position as shown in **FIG. 19-2**.
7. Install upper pin (**FIG. 19-2**) and roll pin in upper end of cylinder and runner.
8. Install lower pin (**FIG. 19-2**) and roll pin in lower end of cylinder and inside coupling.
9. Reconnect hydraulic hose to cylinder (**FIG. 19-2**).

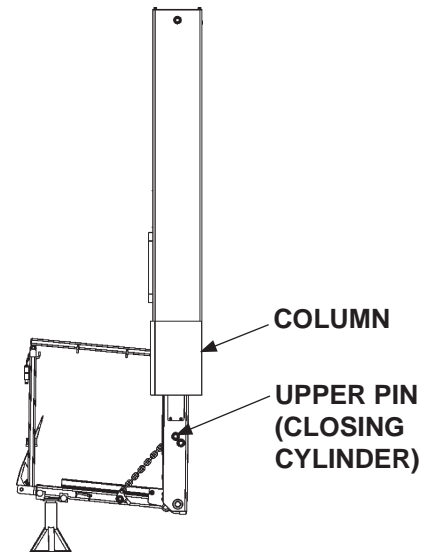

FIG. 19-1

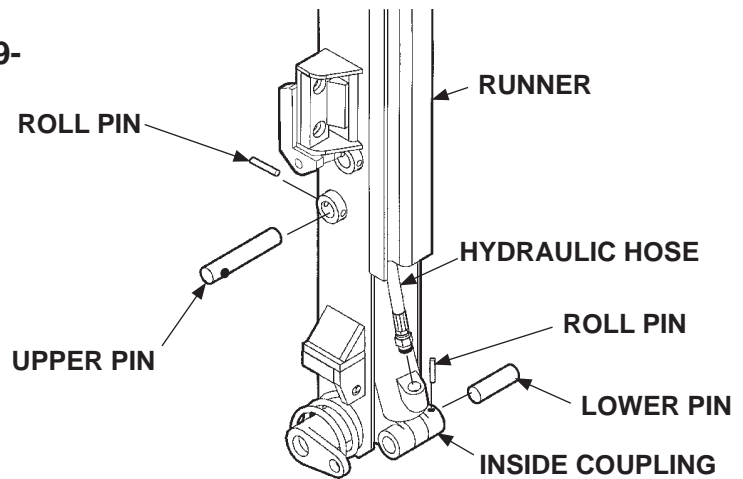

FIG. 19-2

REPLACING PARTS

LIFTING CYLINDER REPLACEMENT

⚠ WARNING

Use floor jack and jack stands to support platform while performing this procedure.

1. Raise the open platform about 20" above the ground. Place a jack and jack stands under the platform (**FIG. 20-1**) for support. Measure and record the distance between the centers of upper and lower cylinder pins. Keep measurement for reference when installing new cylinder.

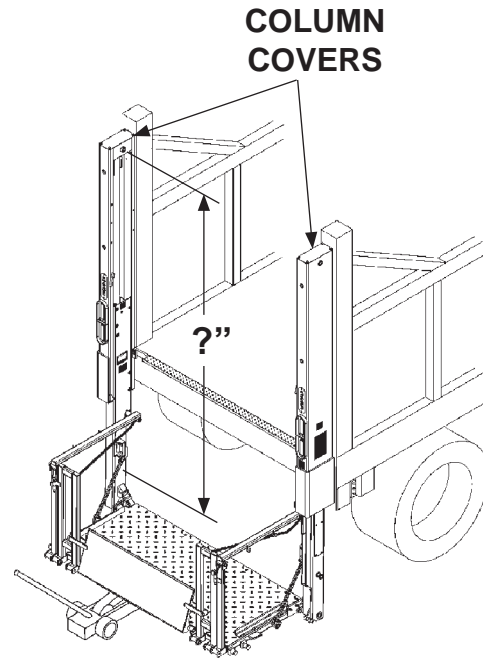

FIG. 20-1

2. Remove cover from the top of the column (**FIG. 20-1**). Put empty oil drain pan under column.
3. Loosen and disengage nut #1 (**FIG. 20-2**) from elbow on top of cylinder. Remove elbow from cylinder (**FIG. 20-2**). Keep elbow to reinstall on new cylinder. Loosen and disengage nut #2 from bottom of flow compensator valve while pushing control switch **DOWN** at the same time.

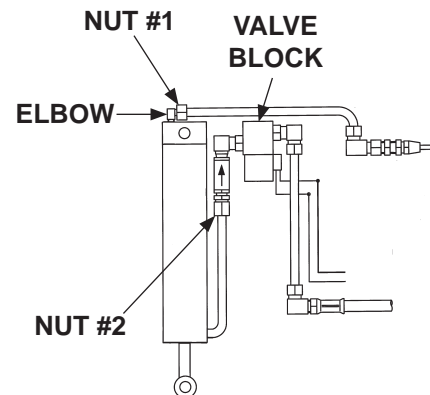
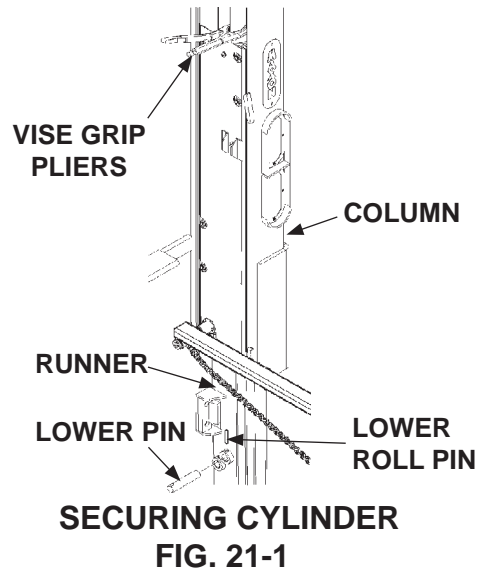

FIG. 20-2

MAXON[®]

11921 Slauson Ave. Santa Fe Springs, CA. 90670 (800) 227-4116 FAX (888) 771-7713

4. Remove lower roll pin & lower pin from cylinder (**FIG. 21-1**). Clamp large, curved vise grip pliers around the hydraulic cylinder just above the top of the runner as shown in **FIG. 21-1**.



5. Remove upper roll pin & upper pin from cylinder (**FIG. 21-2**). Lift cylinder about 4" above top of column.

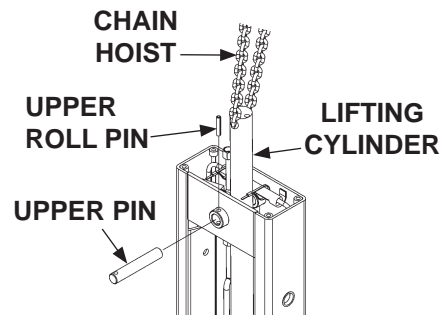

6. Attach a chain hoist or equivalent lifting device to support the upper end of cylinder (**FIG. 21-2**). Remove vise grip pliers from cylinder. Hoist the cylinder until it clears the top of column. Lower cylinder to the ground.

CAUTION
Move old cylinder out of the way to prevent possible trip hazard.

7. Remove plastic plug from line fitting on new cylinder. To prevent fluid spills, fasten a drain hose with 1/4" NPT female end to line fitting on bottom end of cylinder as shown in **FIG. 21-3**. Fully extend cylinder rod. Next, push cylinder rod into cylinder until distance measured between butt-end and rod-end pin bores is the same as distance recorded in **Step 1**.

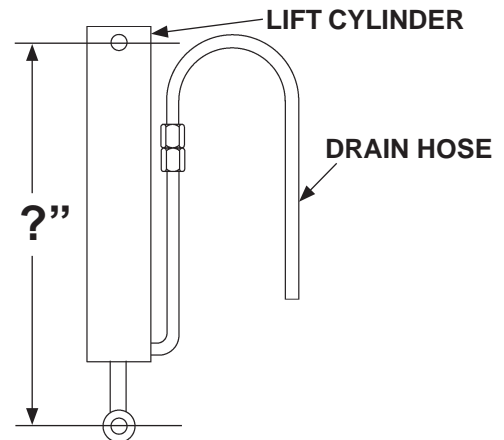

REPLACING PARTS

LIFTING CYLINDER REPLACEMENT - Continued

NOTE: Before installing a new cylinder, get a helper. Have the helper look through square inspection hole on back of runner while cylinder is lowered. The helper can inform installer when rod end of cylinder is lined up with lower pin.

NOTE: To install cylinder correctly, make sure hydraulic lines on cylinder are facing the vehicle body.

8. To install new Lifting cylinder, reverse **Steps 6, 5, 4, 3, and 2.**

9. Remove jack stands. Lower jack and platform all the way (**FIG. 22-1**). Pressurize hydraulic system by pushing control switch to **UP** position. Release switch when platform is raised to bed height.

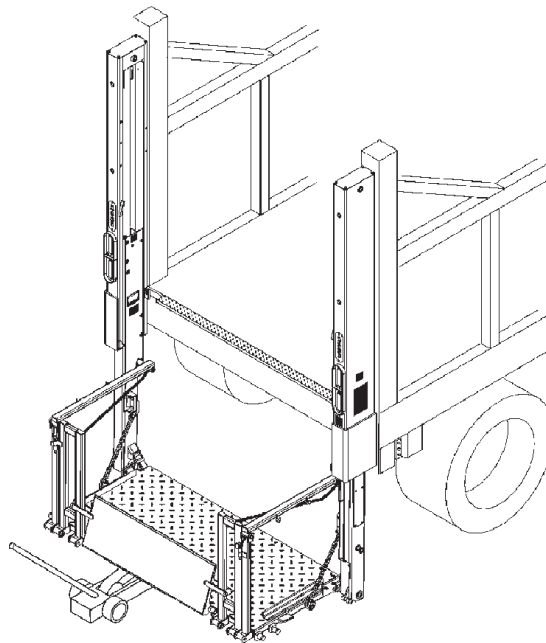

FIG. 22-1

MAXON[®]

11921 Slauson Ave. Santa Fe Springs, CA. 90670 (800) 227-4116 FAX (888) 771-7713

RUNNER REPLACEMENT

1. Use Control Box to Lower the Platform (**DOWN**) to approximately 12" above the ground. Support Platform with 2 jack stands (**FIG. 23-1**). Make sure outboard edge of Platform is 4" higher than inboard edge.

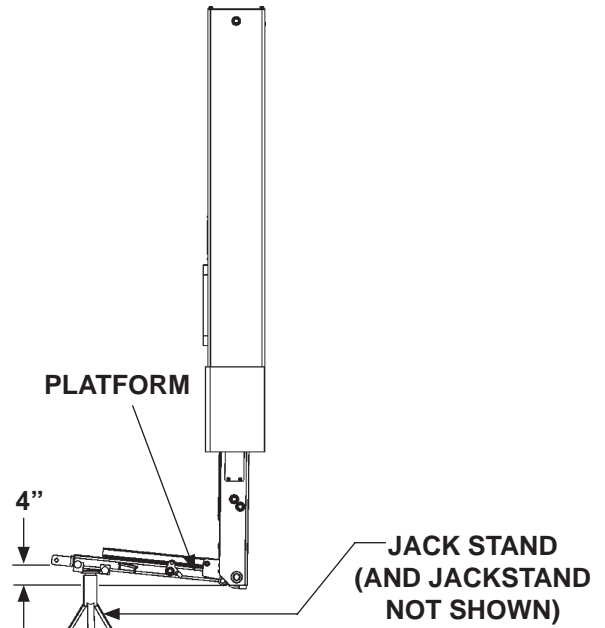

FIG. 23-1

2. Remove the Bolts and Pins (**FIG. 23-2**) holding Platform and Connector Bar to RH & LH Runners. Next, remove Cotter Pins and Pins to remove Chains from both Runners (**FIG. 23-3**). If Liftgate is equipped with CS Platform, remove Roll Pins and Pins to remove Railings from both Runners (**FIG. 23-3**). Unbolt and remove Cover from Runner.

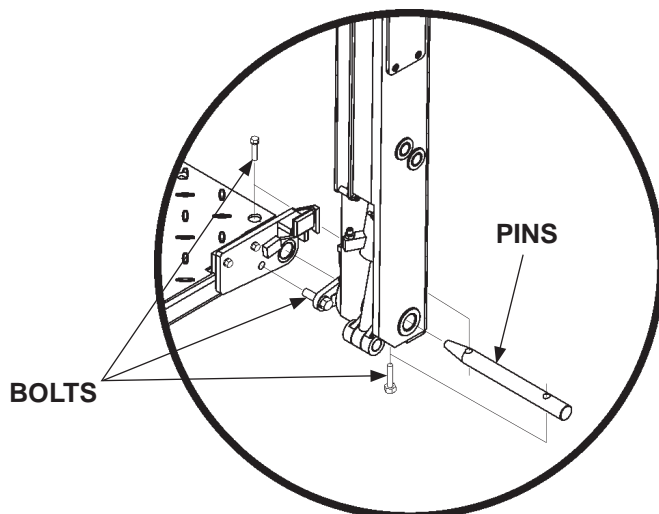

FIG. 23-2

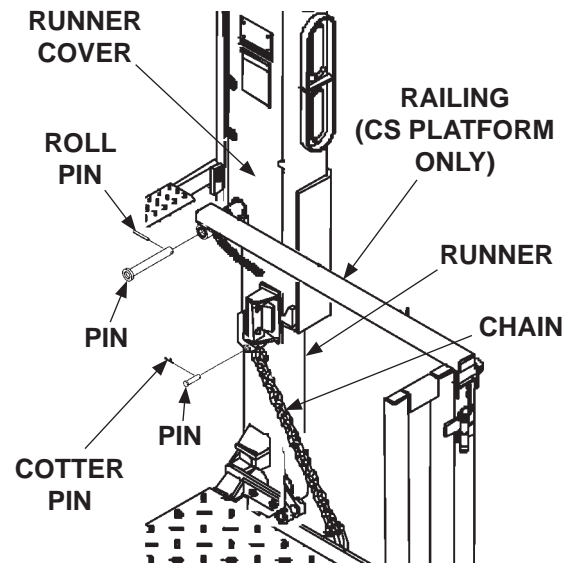

FIG. 23-3

REPLACING PARTS

RUNNER REPLACEMENT - Continued

3. Raise the platform (**UP**) slightly and place 2 more jack stands near the inboard edge (**FIG. 24-1**).

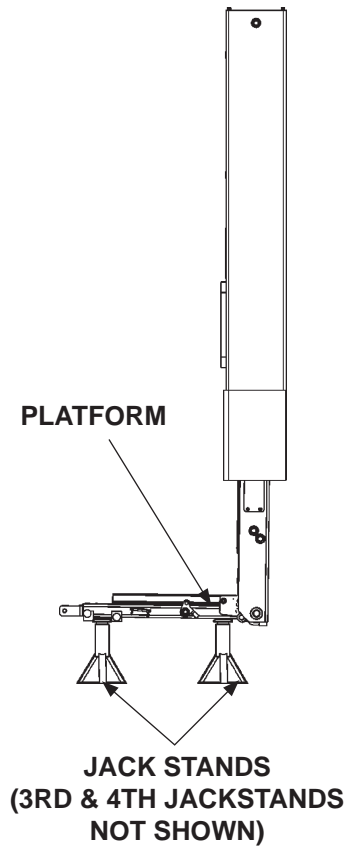

FIG. 24-1

4. Use a forklift or equivalent lifting device to move the platform approximately 6" towards the front of the vehicle to clear the platform away from the attaching points on the runners (**FIG. 24-2**). Now that the platform is clear of runners, raise the runners a few inches and move platform toward the back of the vehicle for sufficient room to remove the runners. Use the control box to lower runners (**DOWN**) to the ground.

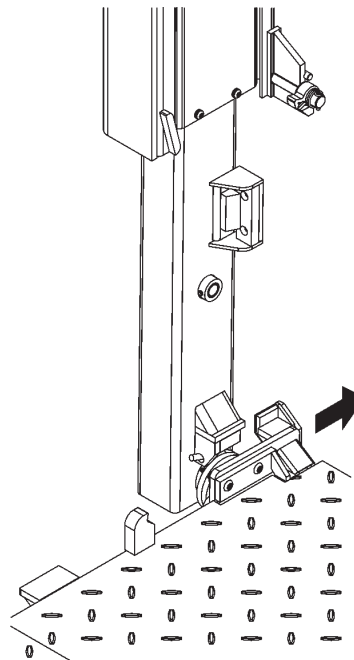

FIG. 24-2

MAXON[®]

11921 Slauson Ave. Santa Fe Springs, CA. 90670 (800) 227-4116 FAX (888) 771-7713

NOTE: If replacing LH runner, skip steps 6, 7, 8, and 9.

5. Disconnect runner switch cable from flexible cable near bottom of runner as shown in **FIG. 25-1**. Unclamp runner switch cable from runner by removing lock nut, clamp, and screw (**FIG. 25-1**). Next, remove clamp from runner switch cable.
6. Disconnect hydraulic hose from closing cylinder (**FIG. 25-1**). Use drain pan to collect hydraulic fluid from hose.
7. Pull spring guard, flexible cable, and hydraulic hose away from the channel at bottom of runner (**FIG. 25-1**).

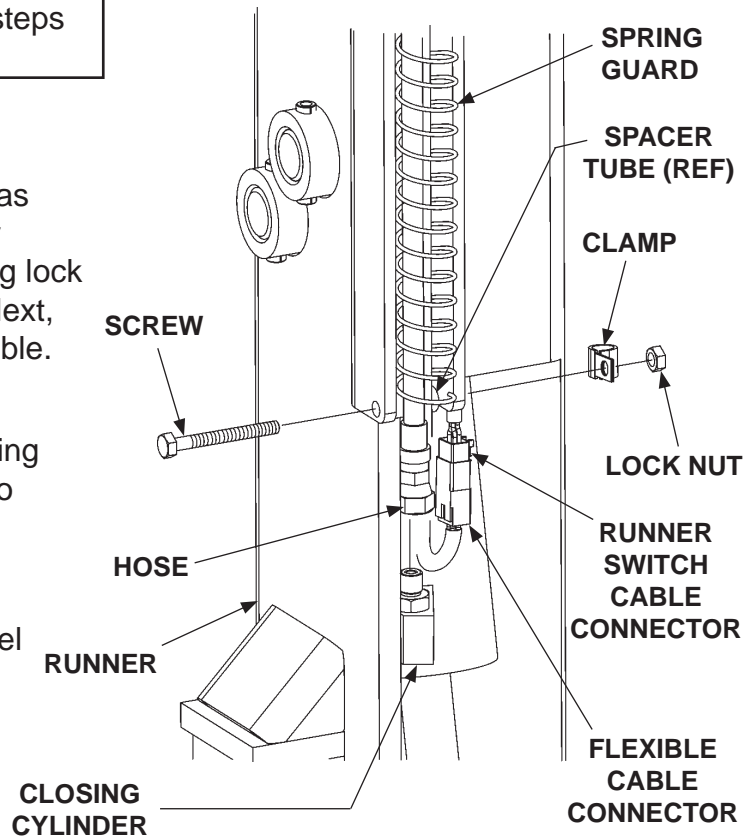

FIG. 25-1

8. Remove the upper and lower pad assemblies (**FIGS. 25-2A & -2B**) from runner (**FIG. 25-2C**) by loosening and removing (2) hex head bolts and (2) lock washers from each pad.

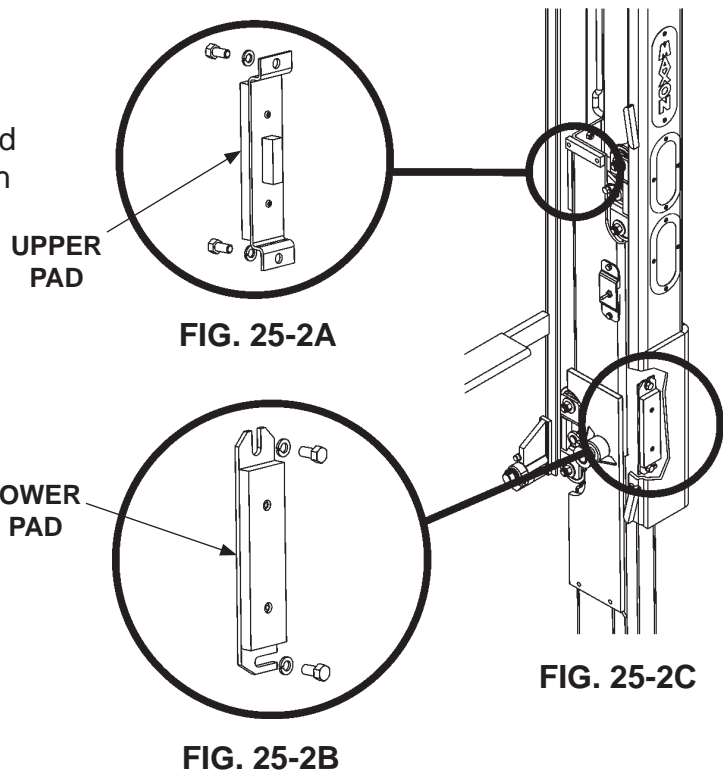

FIG. 25-2A

FIG. 25-2B

FIG. 25-2C

REPLACING PARTS

RUNNER REPLACEMENT - Continued

9. Remove tandem assemblies by loosening and removing bolts and washers from anchor pins (FIG. 26-1). Remove the anchor pins (FIG. 26-1) holding tandem assemblies to runner. Remove the tandem assemblies (FIG. 26-1).

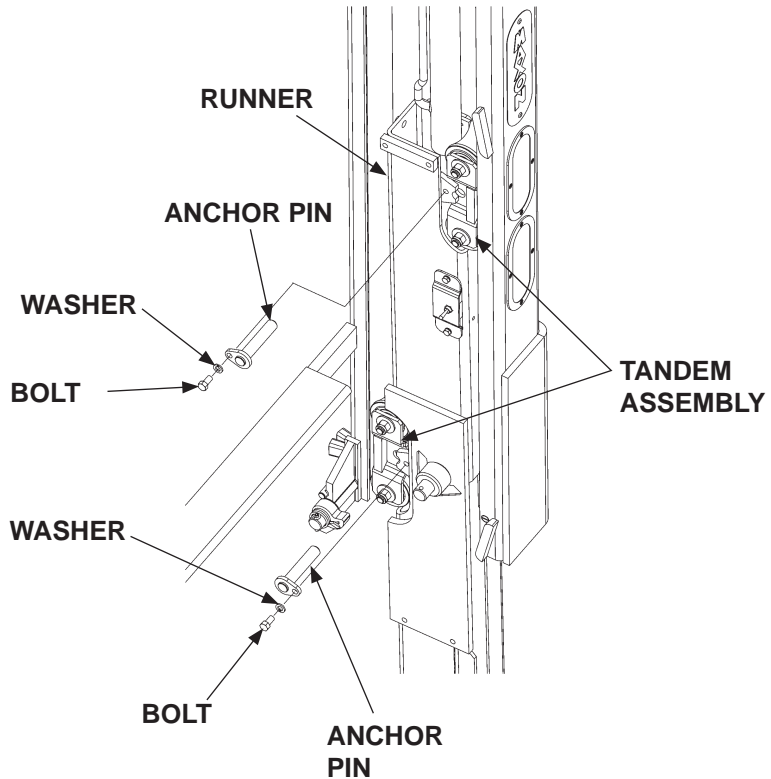

FIG. 26-1

10. Disconnect hydraulic line to cylinder. Hold cylinder firmly and remove upper roll pin and upper pin (FIG. 26-2).

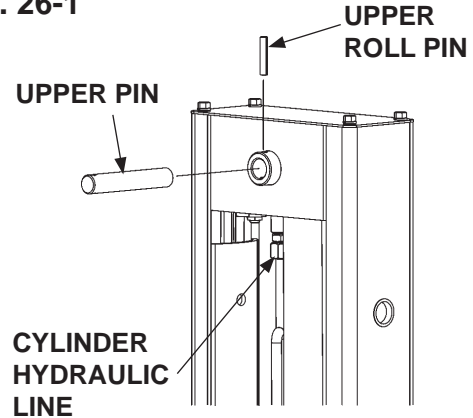

FIG. 26-2

11. Lower cylinder slowly to clear top of column. Disconnect hydraulic line on the top of cylinder (FIG. 26-3).

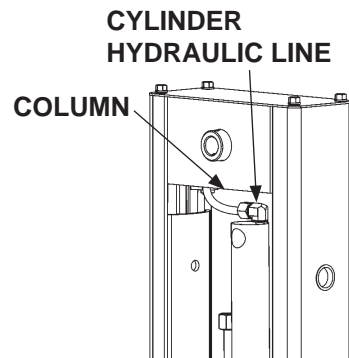

FIG. 26-3

MAXON[®]

11921 Slauson Ave. Santa Fe Springs, CA. 90670 (800) 227-4116 FAX (888) 771-7713

12. Use large round jaw vise grip pliers to clamp cylinder at the top of runner (FIG. 27-1).

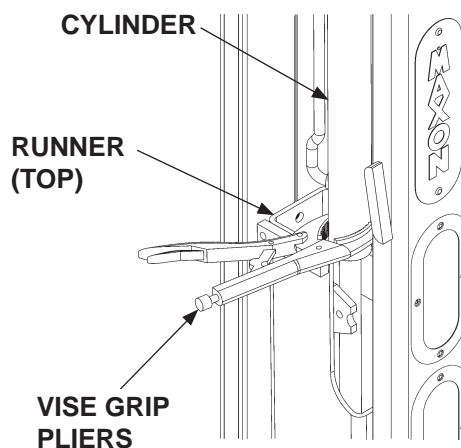

FIG. 27-1

13. Twist and walk runner out of column (FIG. 27-2). Then lay runner and cylinder on the ground.

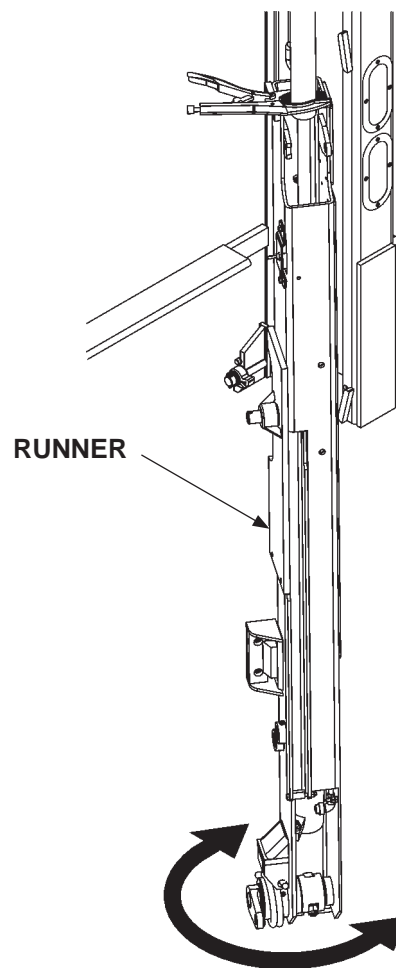

FIG. 27-2

REPLACING PARTS RUNNER REPLACEMENT - Continued

14. Remove vise grip clamp, and mark cylinder at top of runner (FIG. 28-1).

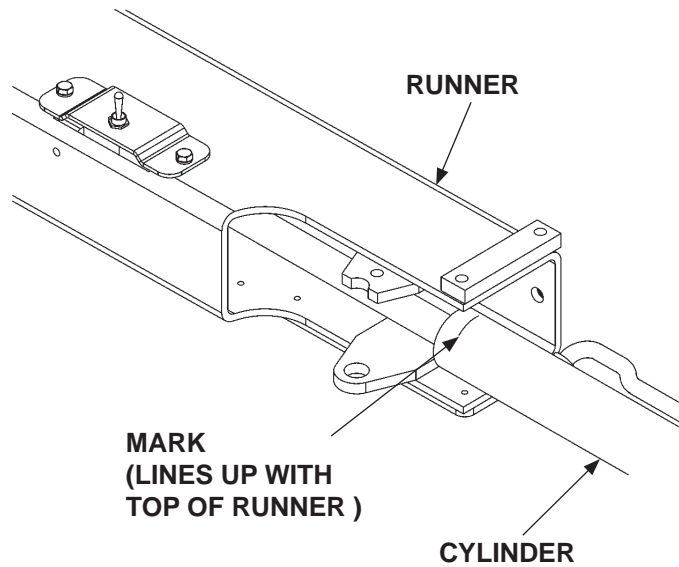

FIG. 28-1

15. Remove lower roll pin and lower pin. Pull out cylinder from runner (FIG. 28-2).

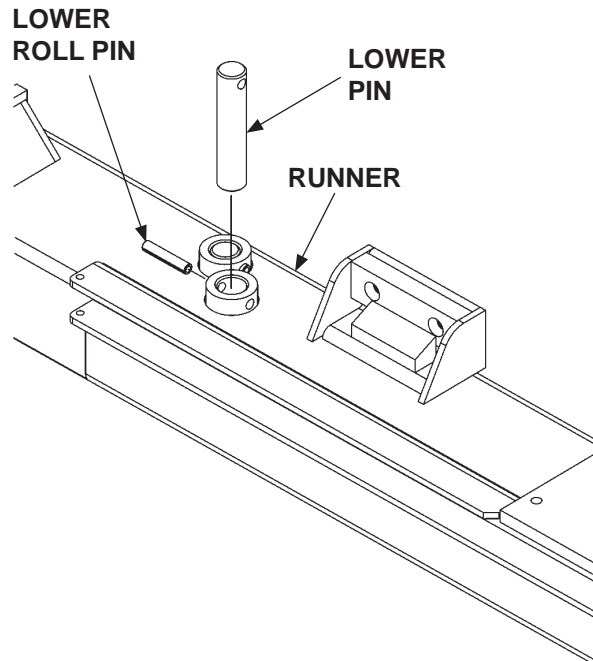

FIG. 28-2

16. If RH runner is being replaced, do the **CLOSING CYLINDER REPLACEMENT** procedure in this section to remove closing cylinder.

MAXON[®]

11921 Slauson Ave. Santa Fe Springs, CA. 90670 (800) 227-4116 FAX (888) 771-7713

17. If RH runner is being replaced, unbolt switch mounting bracket from runner by removing (2) bolts and (2) lock washers (**FIG. 29-1**). Pull runner switch, bracket, and cable from runner.

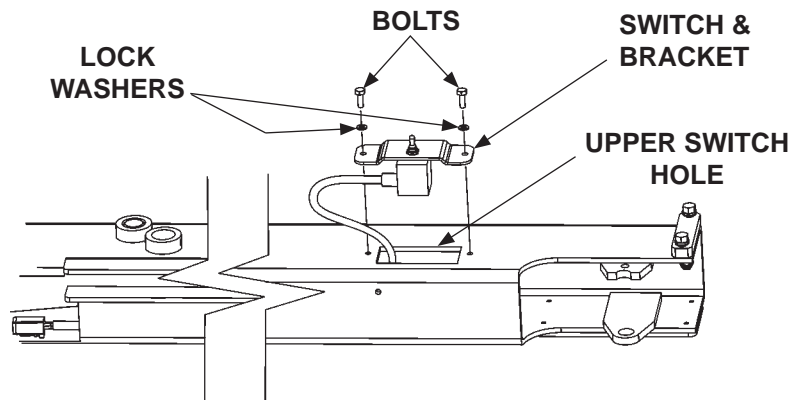

FIG. 29-1

CAUTION

Avoid making sharp bends in wiring.

18. If RH runner is being replaced, reinstall runner switch, bracket, and cable in runner as follows. Make a wire fish by feeding 8 feet of small gauge wire through upper switch hole in runner (**FIG. 29-1**). Pull wire through channel at lower end of column. Leave enough wire at upper hole to attach to switch cable, and leave enough wire to pull at the lower end of runner. Tie upper end of wire fish to runner switch cable connector. Pull connector with cable through runner until connector exits lower end of column. Bolt switch mounting bracket to runner with (2) bolts and (2) lock washers (**FIG. 29-1**).
19. If RH runner is being replaced, do the **CLOSING CYLINDER REPLACEMENT** procedure, in this section, to reinstall closing cylinder.

REPLACING PARTS RUNNER REPLACEMENT - Continued

20. Slide cylinder into runner. Re-install lower roll pin and lower pin (FIG. 30-1).

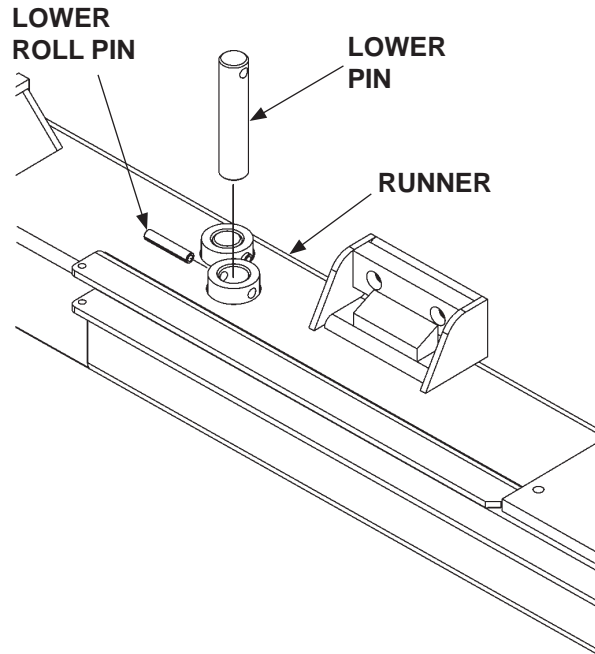

FIG. 30-1

21. Clamp large round jaw vise grip pliers at mark on cylinder (FIG. 30-2). Line up with top of runner.

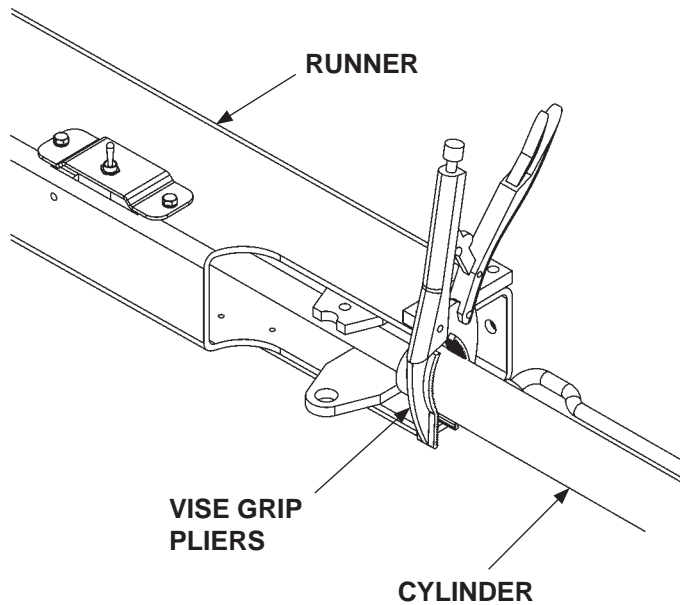

FIG. 30-2

MAXON[®]

11921 Slauson Ave. Santa Fe Springs, CA 90670 (800) 227-4116 FAX (888) 771-7713

22. Stand the runner and cylinder upright. Twist and walk runner into column (**FIG. 30-1**).

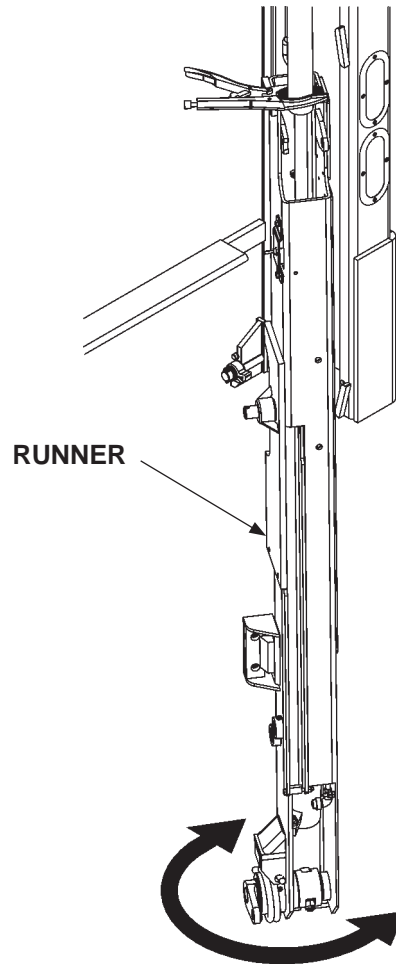

FIG. 31-1

23. Connect hydraulic line on top of cylinder (**FIG. 31-2**). Raise the cylinder slowly to top of column.

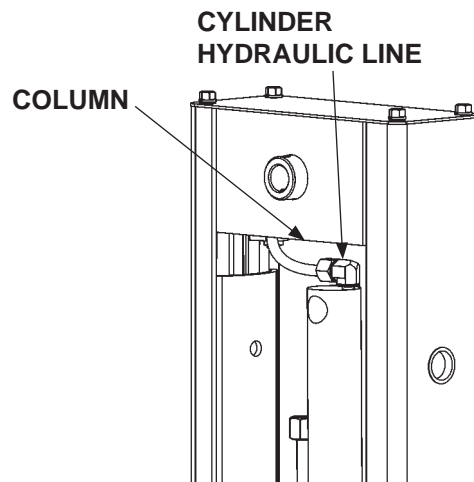

FIG. 31-2

REPLACING PARTS

RUNNER REPLACEMENT - Continued

24. Holding the cylinder firmly, reinstall upper roll pin and upper pin (**FIG. 32-1**). Reconnect hydraulic line to cylinder.

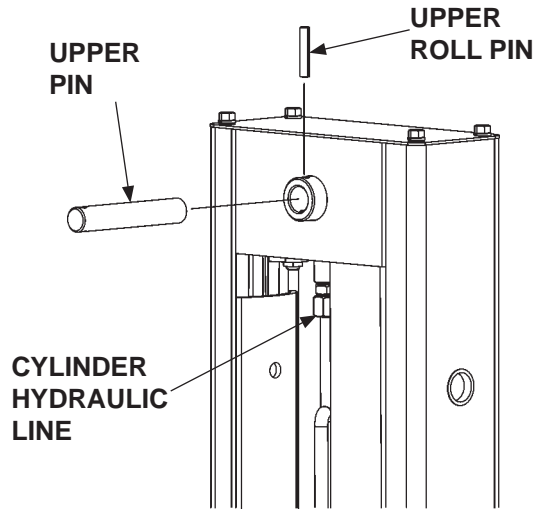

FIG. 32-1

25. Remove vise grip pliers from cylinder.

26. Place tandem assembly in replacement runner as shown in **FIG. 31-2**. Reinstall the anchor pin (**FIG. 31-2**) holding tandem assembly to runner. Bolt the anchor pin to runner (**FIG. 31-2**).

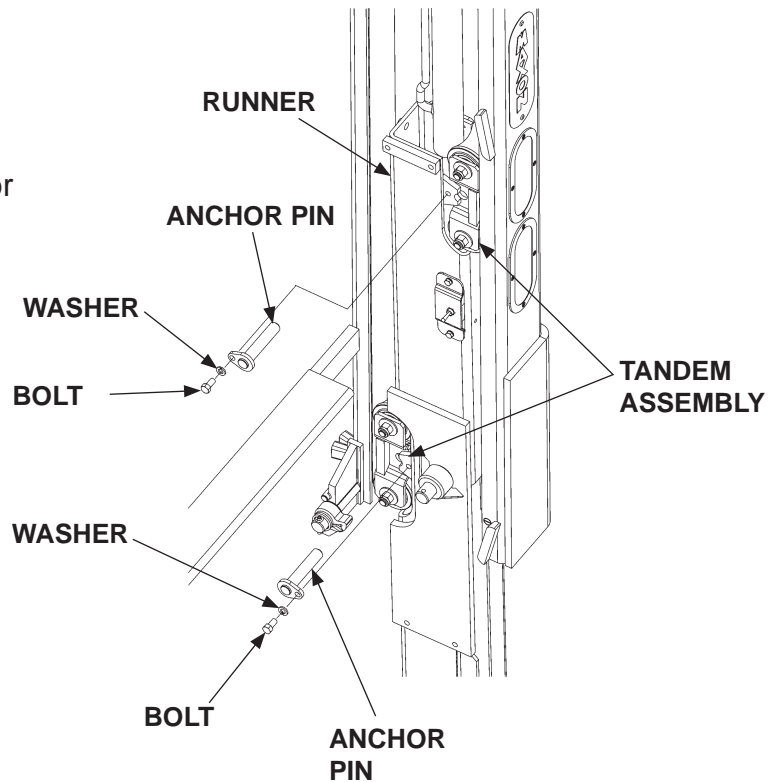
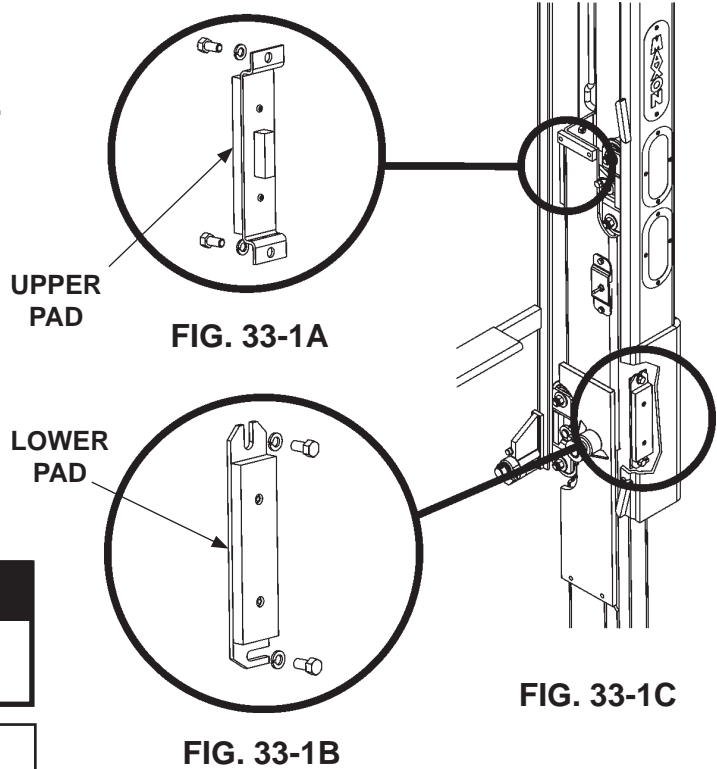

FIG. 32-2

MAXON[®]

11921 Slauson Ave. Santa Fe Springs, CA. 90670 (800) 227-4116 FAX (888) 771-7713

27. Reinstall or replace the upper and lower pads (FIGS. 33-1A & -31B) on the front and back of the runner (FIG. 33-1C). Use (2) hex head bolts and (2) lock washers to bolt each pad to runner.



CAUTION

Make sure electrical cable is not wrapped around hydraulic hose.

NOTE: If replacing LH runner, skip steps 28, 29, and 30.

28. Place spring guard, flexible cable, and hydraulic hose in channel at bottom of runner (FIG. 33-2).
29. Reconnect hydraulic hose to closing cylinder (FIG. 33-2).

CAUTION

Avoid making sharp bends in wiring.

NOTE: MAXON recommends using dielectric grease on all electrical connections.

30. Reconnect runner switch cable to flexible cable at bottom of runner (FIG. 33-2). Clamp the runner switch cable to runner with screw, clamp, and lock nut.

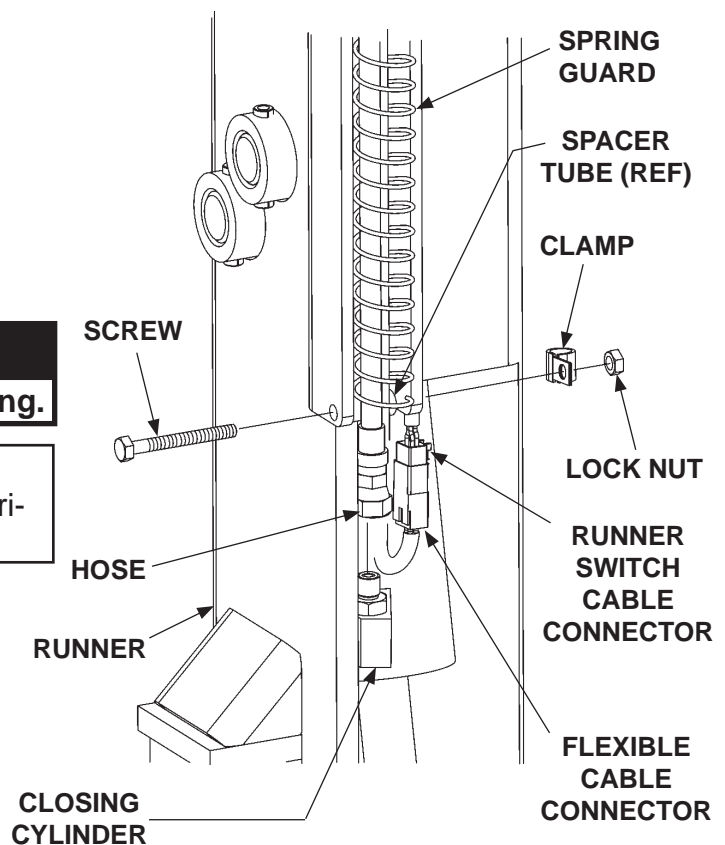

FIG. 33-2

REPLACING PARTS

RUNNER REPLACEMENT - Continued

31. Use a forklift or equivalent lifting device to lift platform and line it up with attaching points on the LH runner (**FIG. 34-1**) and RH runner.

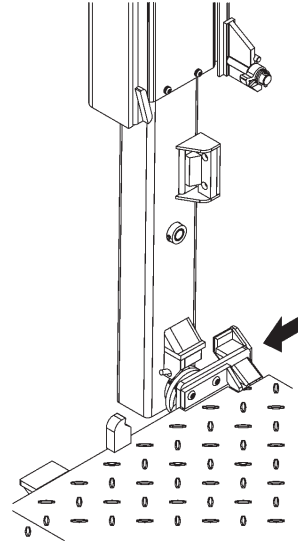

FIG. 34-1

32. Reinstall bolts and pins (**FIG. 34-2**) holding platform and connector bar to RH runner (**FIG. 34-2**) and LH runner.

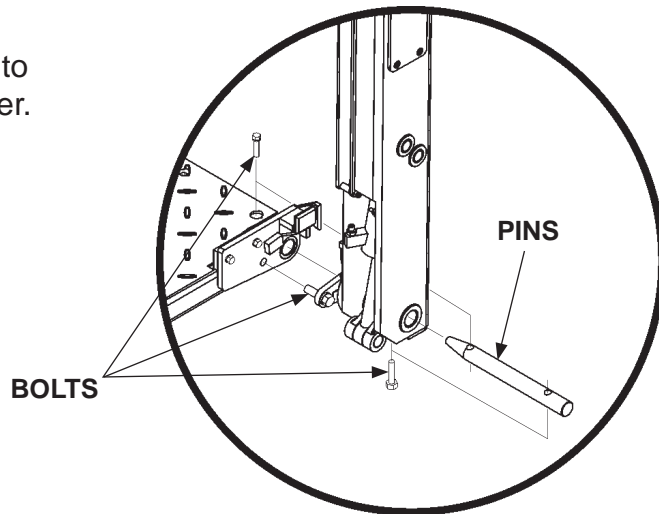

FIG. 34-2

MAXON[®]

11921 Slauson Ave. Santa Fe Springs, CA. 90670 (800) 227-4116 FAX (888) 771-7713

33. Use control box to lower (**DOWN**) platform on jack stands (**FIG. 35-1**) so inboard edge is 4" below ramp edge.

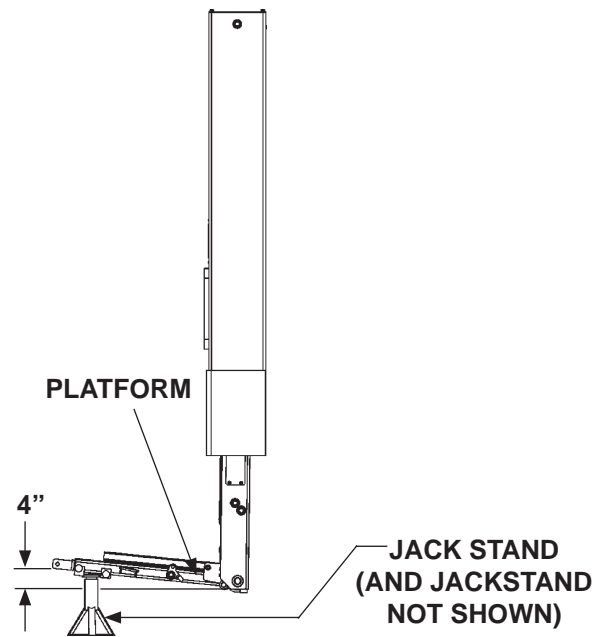

FIG. 35-1

NOTE: Reinstall runner cover, with "ALIGN ARROWS" decal on LH runner.

34. Bolt runner cover to RH runner (**FIG. 35-2**). Then pin chain to RH runner (**FIG. 35-2**). If Liftgate is equipped with CS platform as shown in **FIG. 35-2**, pin railing to RH Runner. Repeat this step for LH runner.

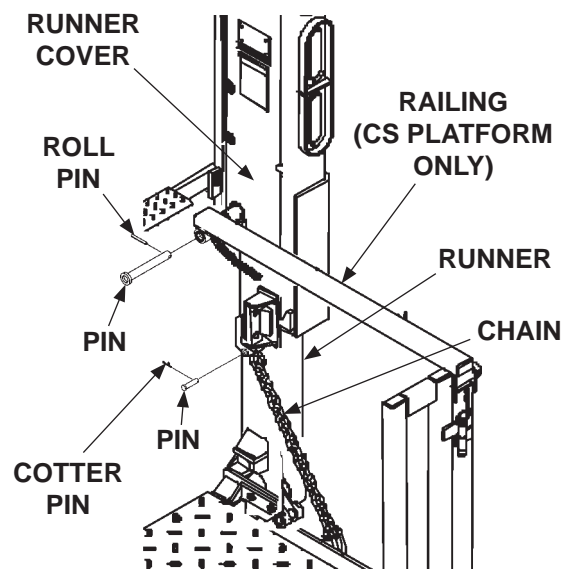

FIG. 35-2

HYDRAULIC SYSTEM DIAGRAMS

PUMP & MOTOR SOLENOID OPERATION

MAXON

11921 Slauson Ave. Santa Fe Springs, CA. 90670 (800) 227-4116 FAX (888) 771-7713

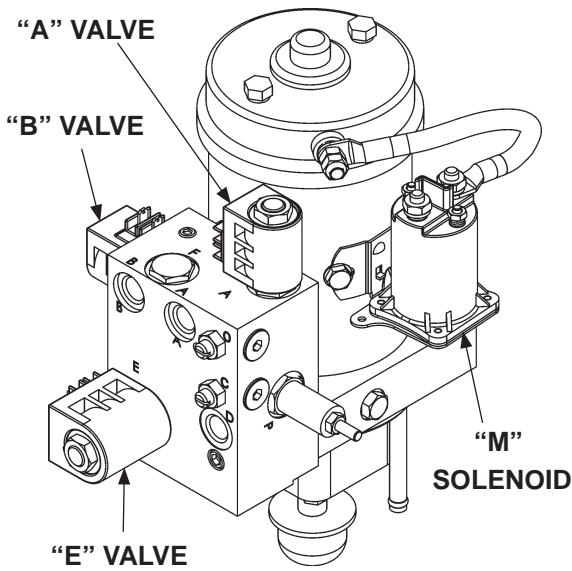

GRAVITY DOWN PUMP/MOTOR
FIG. 36-1

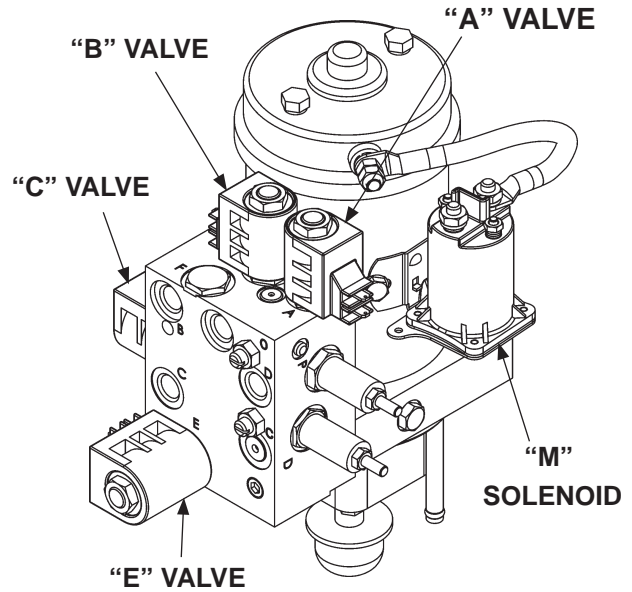

POWER DOWN PUMP/MOTOR
FIG. 36-2

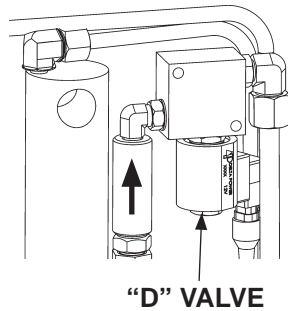

"D" VALVES (TOP OF EACH COLUMN)
FIG. 36-3

SOLENOID OPERATION		
FUNCTION	SOLENOID ENERGIZED	ACTION
UP	M	Motor runs; Oil flows from "B" Port, thru Flow Divider, thru "D" Valves to Lift Cylinders.
DOWN	GRAVITY - B & D (FIG. 1 & 3)	"B & D" Valves open, allowing oil to return from Lift Cylinders to the Reservoir
	POWER - M,B,C,& D (FIG. 2 & 3)	Motor runs; "B,C,& D" Valves open, allowing oil to return from Lift Cylinders to Reservoir.
FOLD PLATFORM	M & E	Motor runs; "E" Valve shifts, Oil flows from Port "A" to the Folding Cylinder.
UNFOLD PLATFORM	A	"A" Valve opens, allowing oil to return from the Folding Cylinder to Reservoir.

TABLE 36-1

HYDRAULIC SCHEMATIC, SINGLE PUMP GRAVITY DOWN

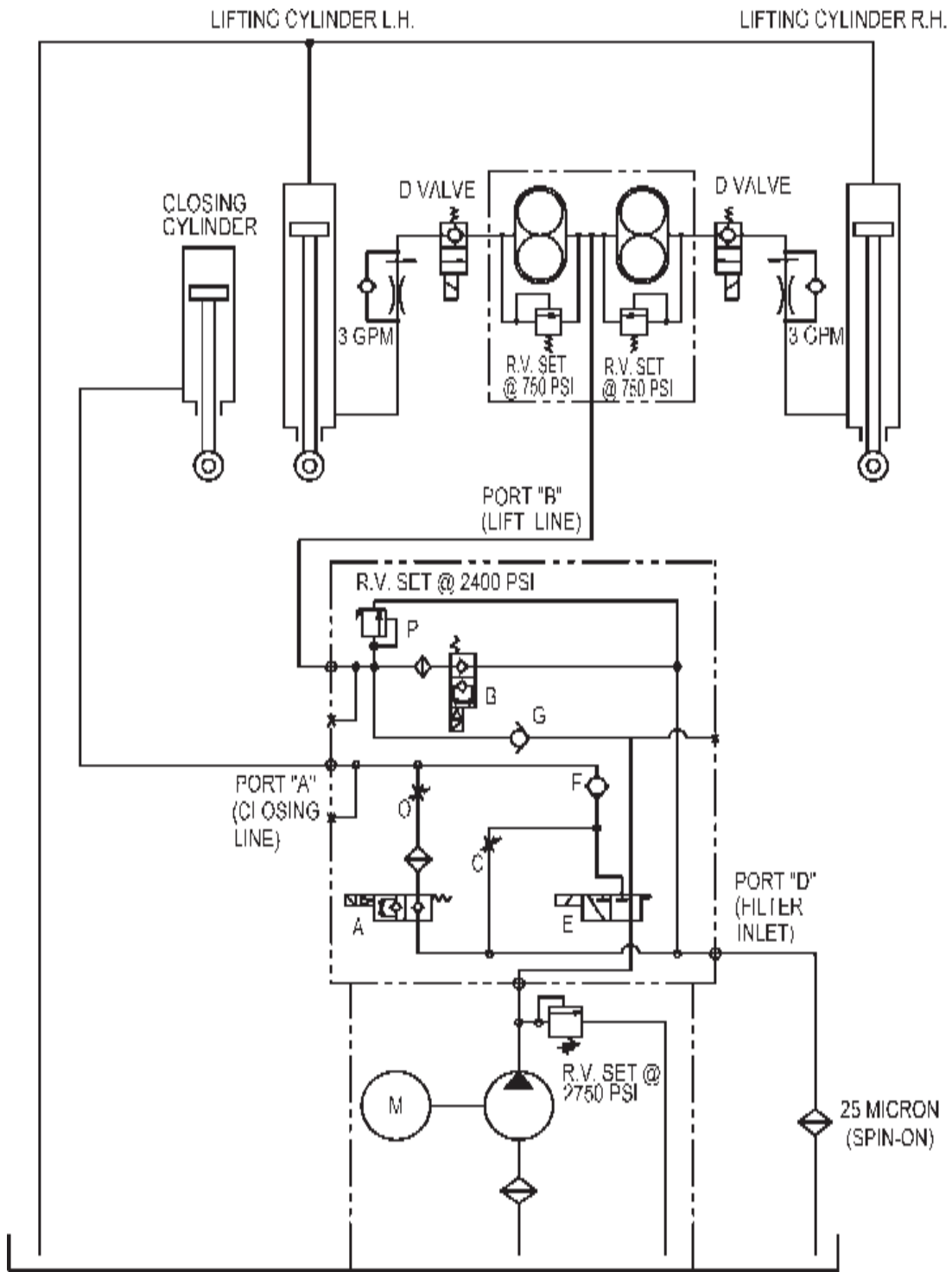

FIG. 37-1

HYDRAULIC SYSTEM DIAGRAMS

HYDRAULIC SCHEMATIC, DUAL PUMP GRAVITY DOWN

MAXON®

11921 Slauson Ave. Santa Fe Springs, CA. 90670 (800) 227-4116 FAX (888) 771-7713

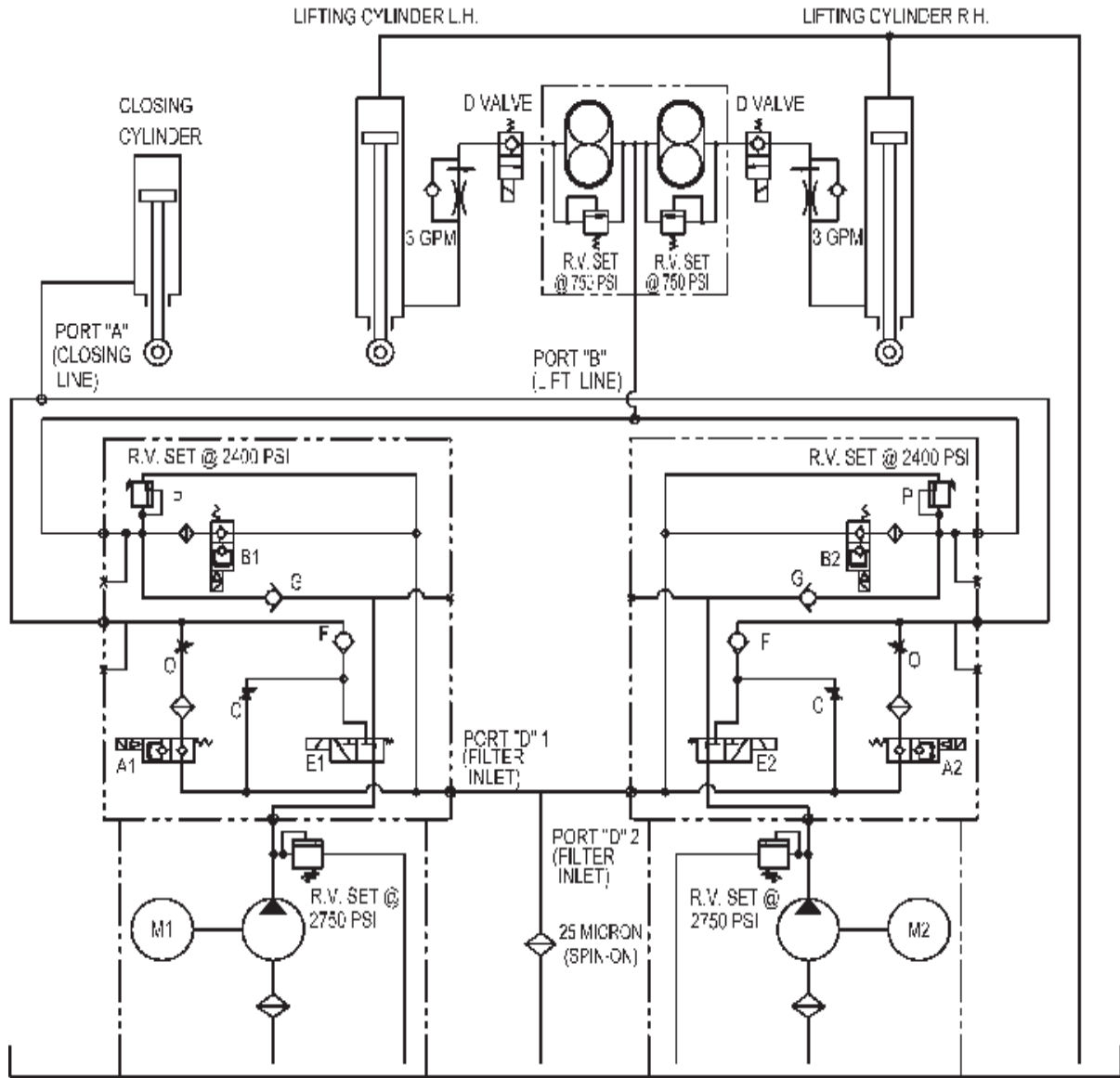

FIG. 38-1

HYDRAULIC SCHEMATIC, SINGLE PUMP POWER DOWN

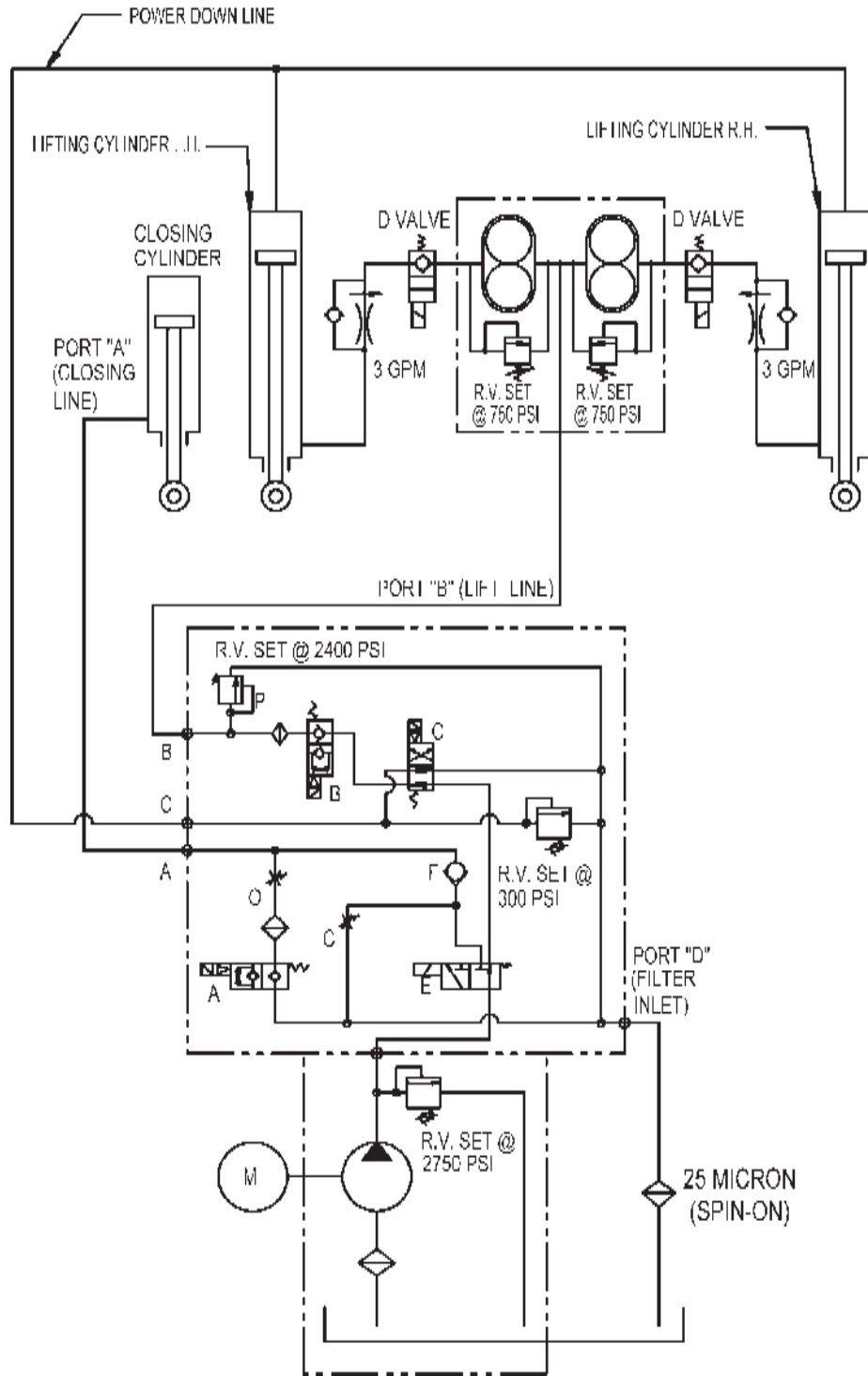

FIG. 39-1

HYDRAULIC SYSTEM DIAGRAMS

HYDRAULIC SCHEMATIC, DUAL PUMP POWER DOWN

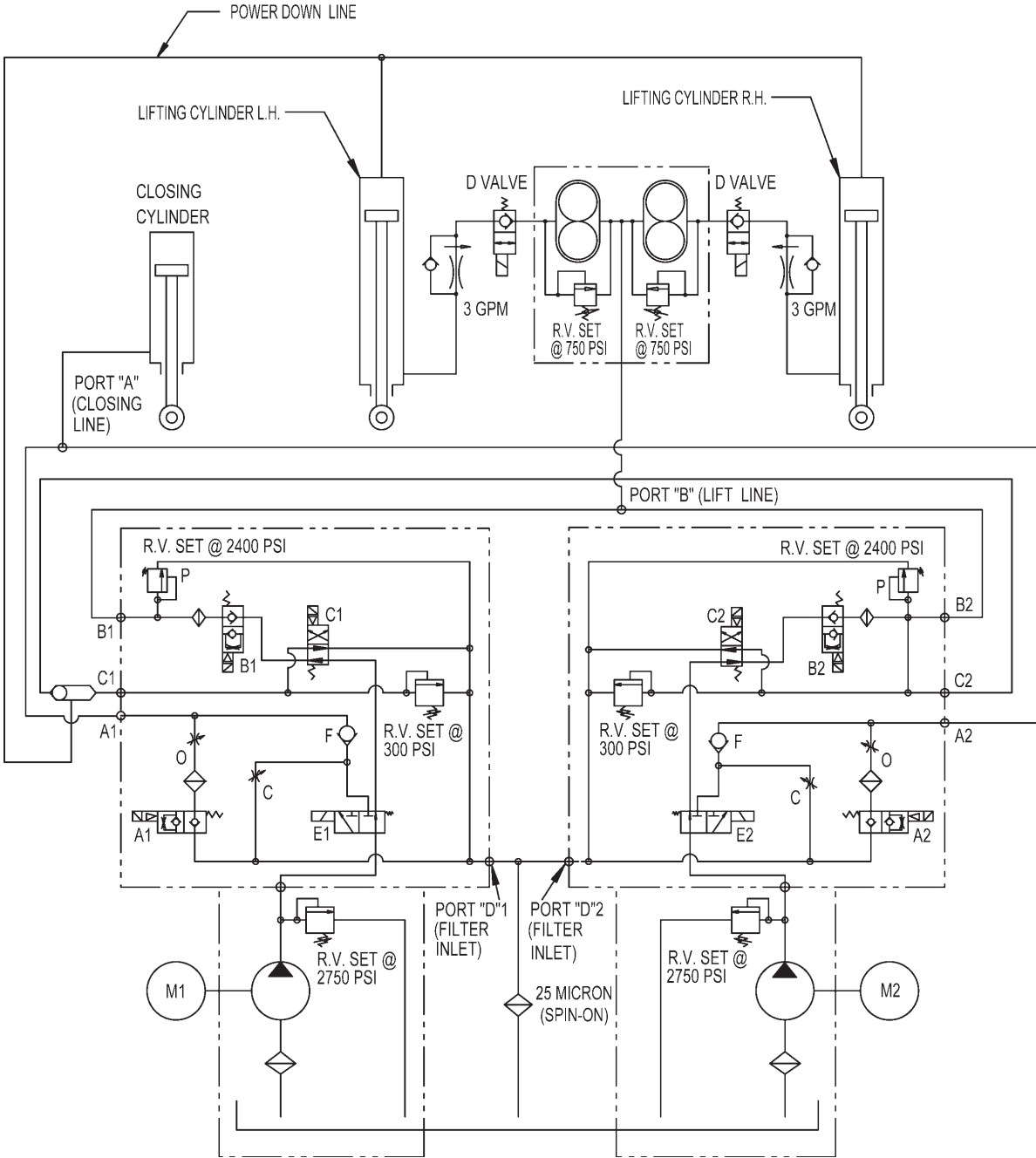

FIG. 40-1

MAXON®

11921 Slauson Ave. Santa Fe Springs, CA. 90670 (800) 227-4116 FAX (888) 771-7713

ELECTRICAL SYSTEM DIAGRAMS WIRING SCHEMATIC, GRAVITY DOWN

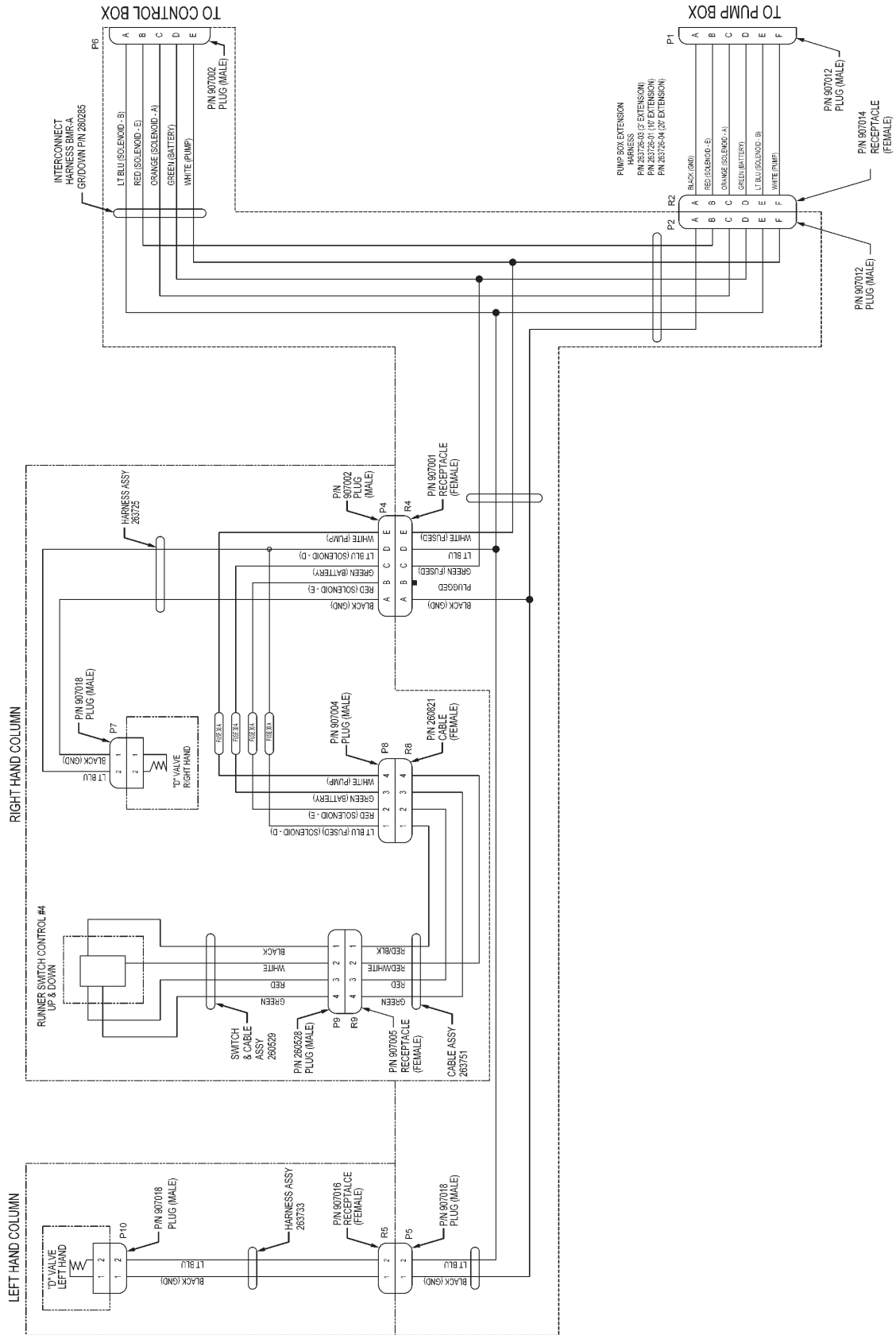

FIG. 41-1

ELECTRICAL SYSTEM DIAGRAMS

SINGLE PUMP BOX, GRAVITY DOWN

MAXON®

11921 Slauson Ave. Santa Fe Springs, CA. 90670 (800) 227-4116 FAX (888) 771-7713

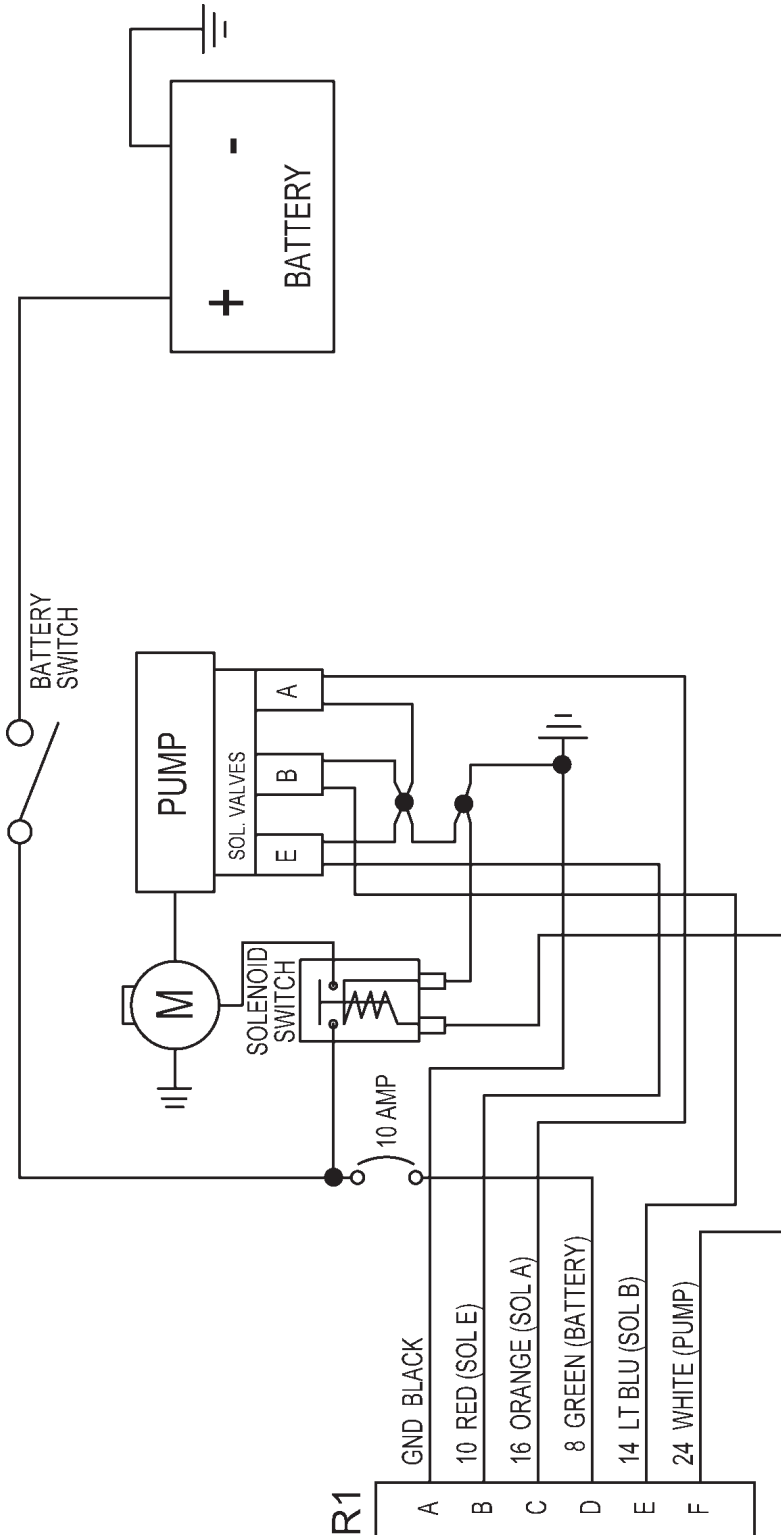

(From receptacle on pump box wall)

FIG. 42-1

DUAL PUMP BOX, GRAVITY DOWN

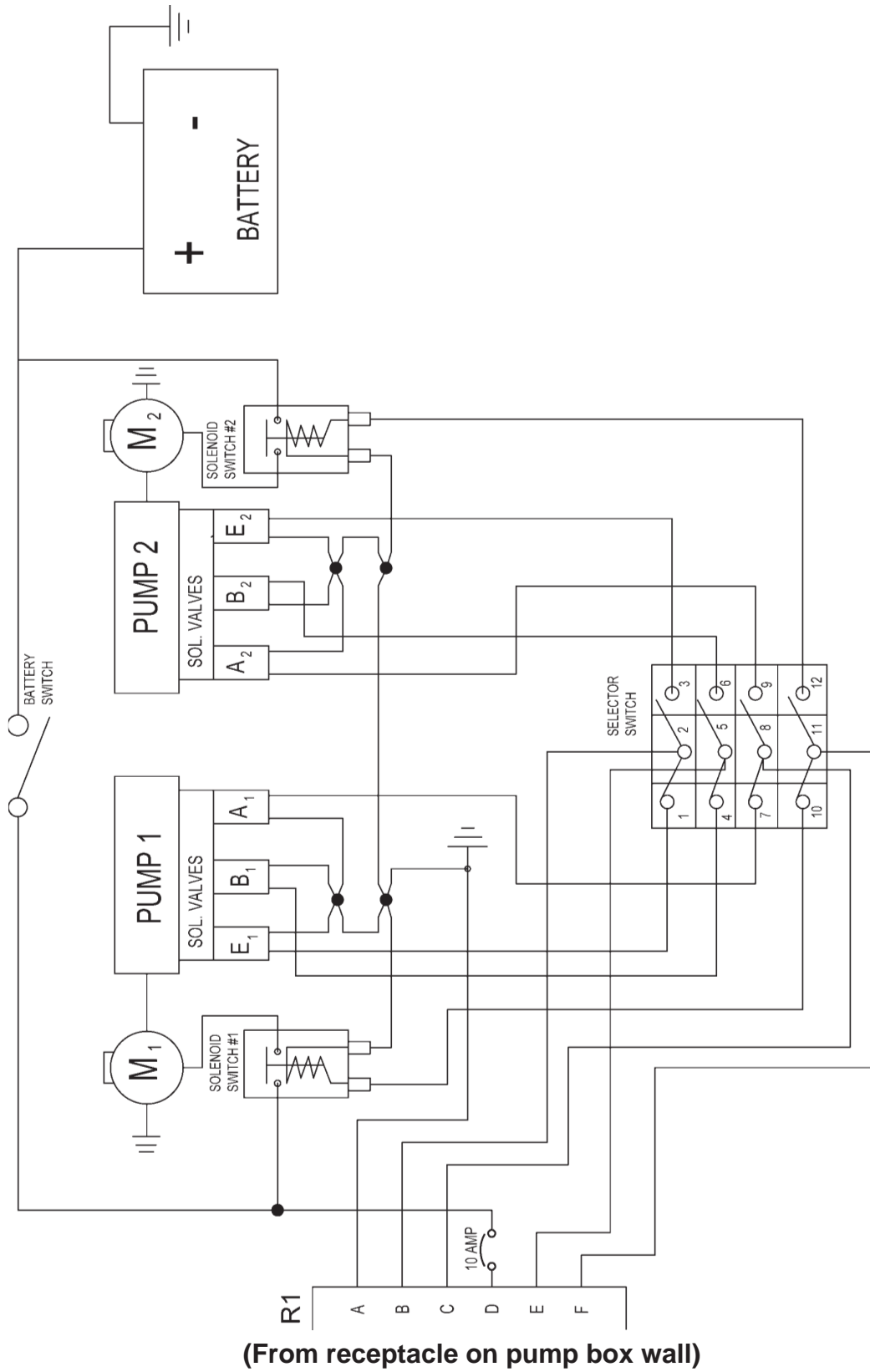

(From receptacle on pump box wall)

FIG. 43-1

ELECTRICAL SYSTEM DIAGRAMS

WIRING SCHEMATIC, POWER DOWN

MAXON®

11921 Slauson Ave. Santa Fe Springs, CA. 90670 (800) 227-4116 FAX (888) 771-7713

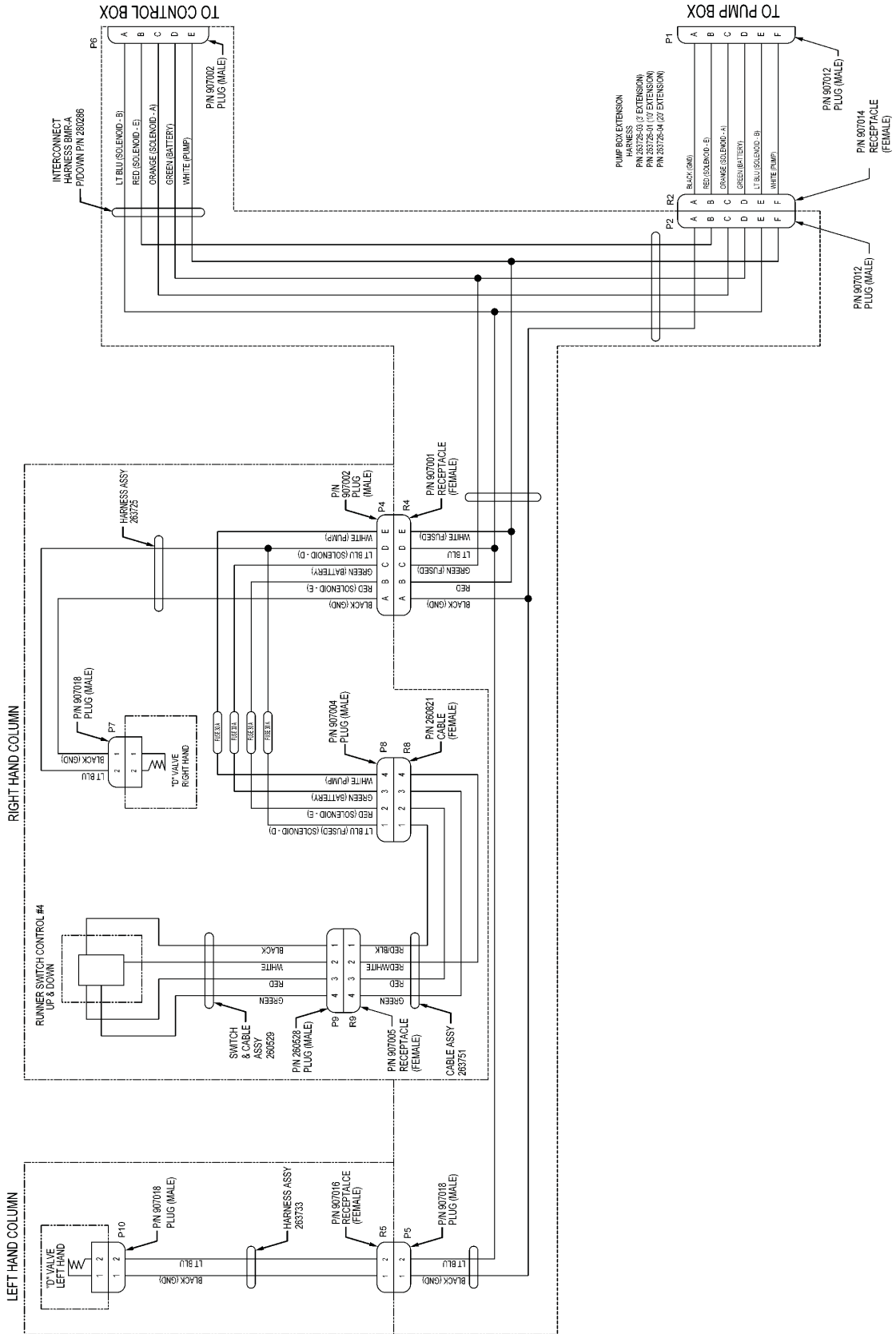
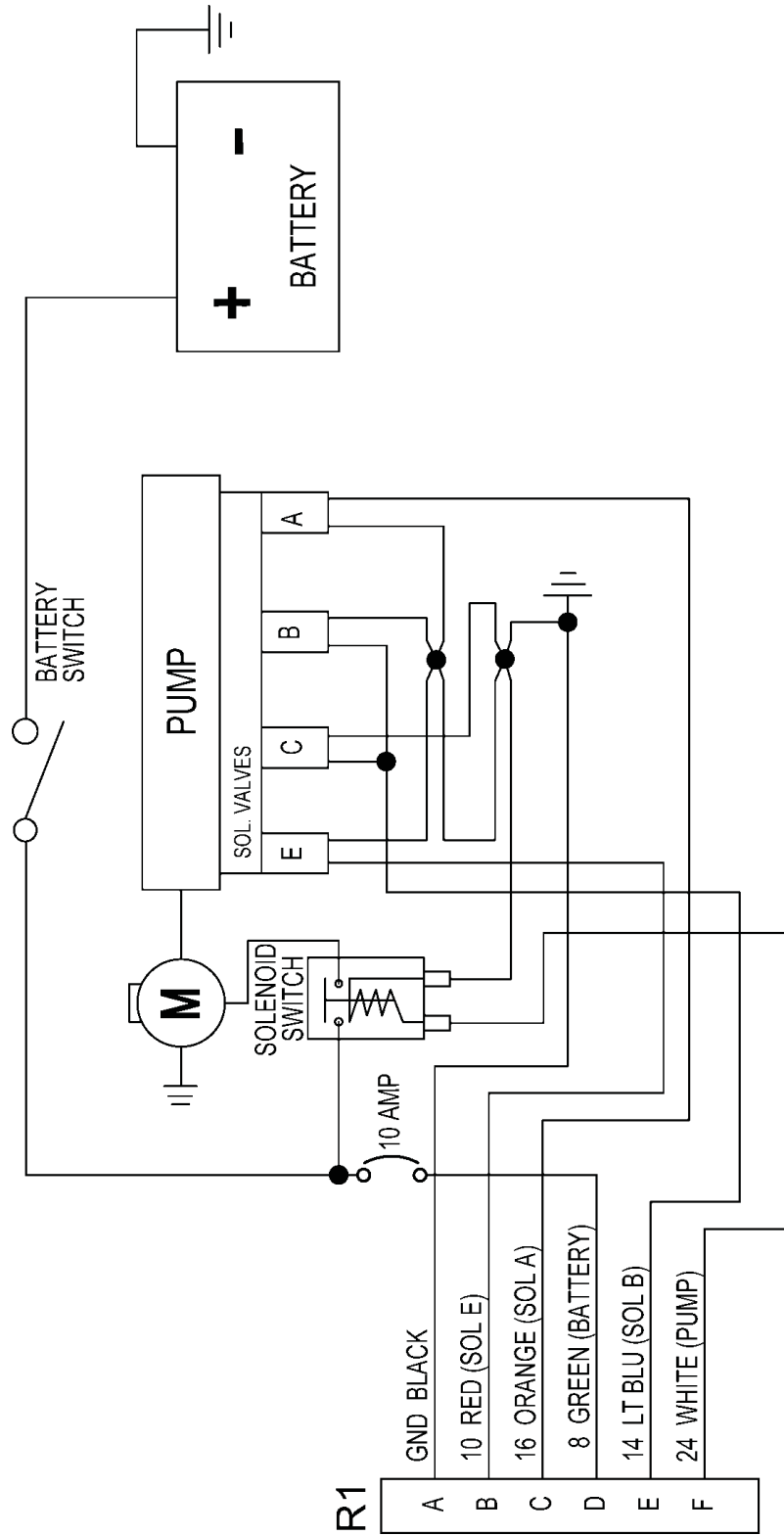

FIG. 44-1

SINGLE PUMP BOX, POWER DOWN



(From receptacle on pump box wall)

FIG. 45-1

ELECTRICAL SYSTEM DIAGRAMS

DUAL PUMP BOX, POWER DOWN

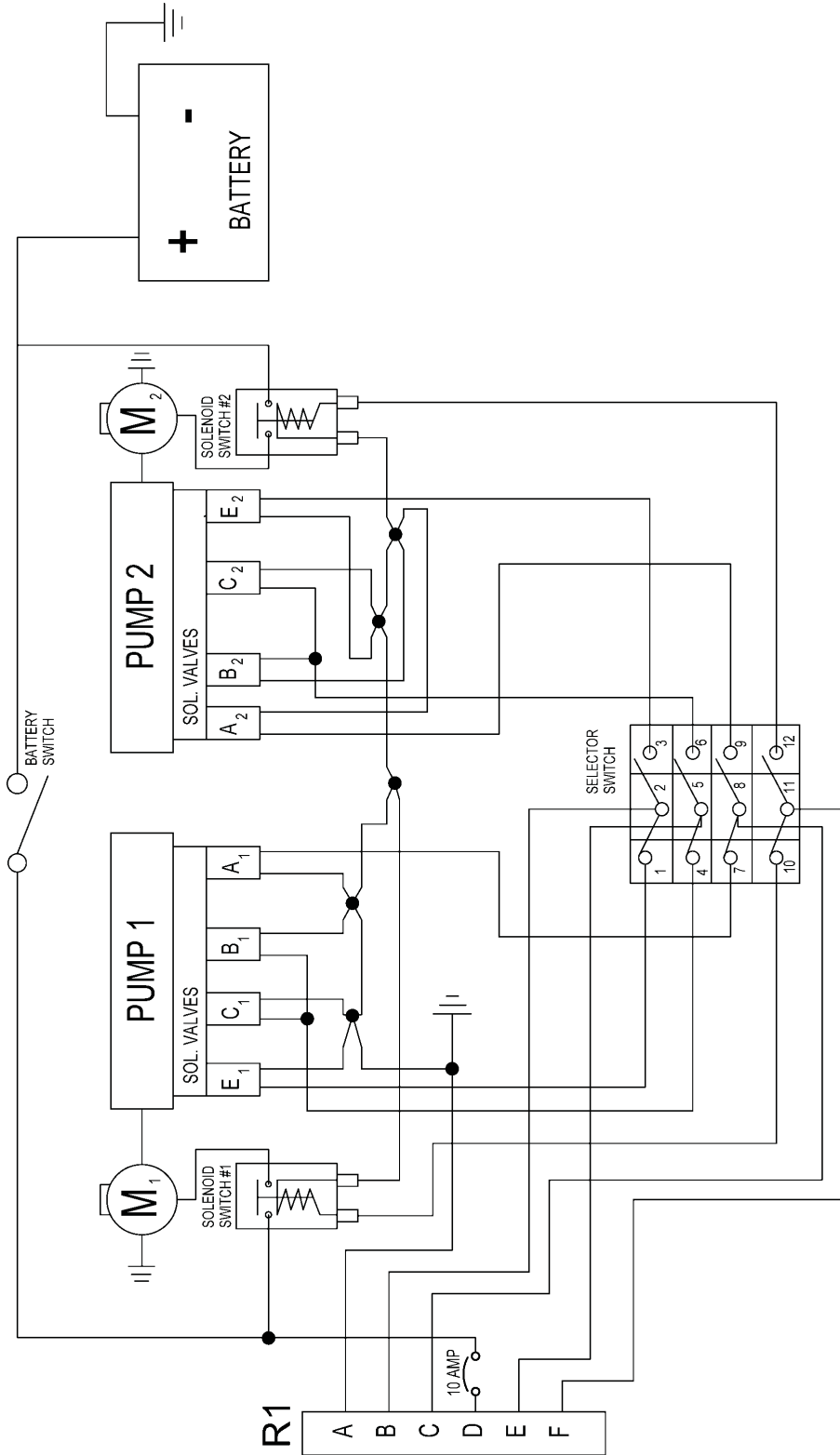

(From receptacle on pump box wall)

FIG. 46-1

WIRING HARNESS CONNECTOR IDENTIFICATION

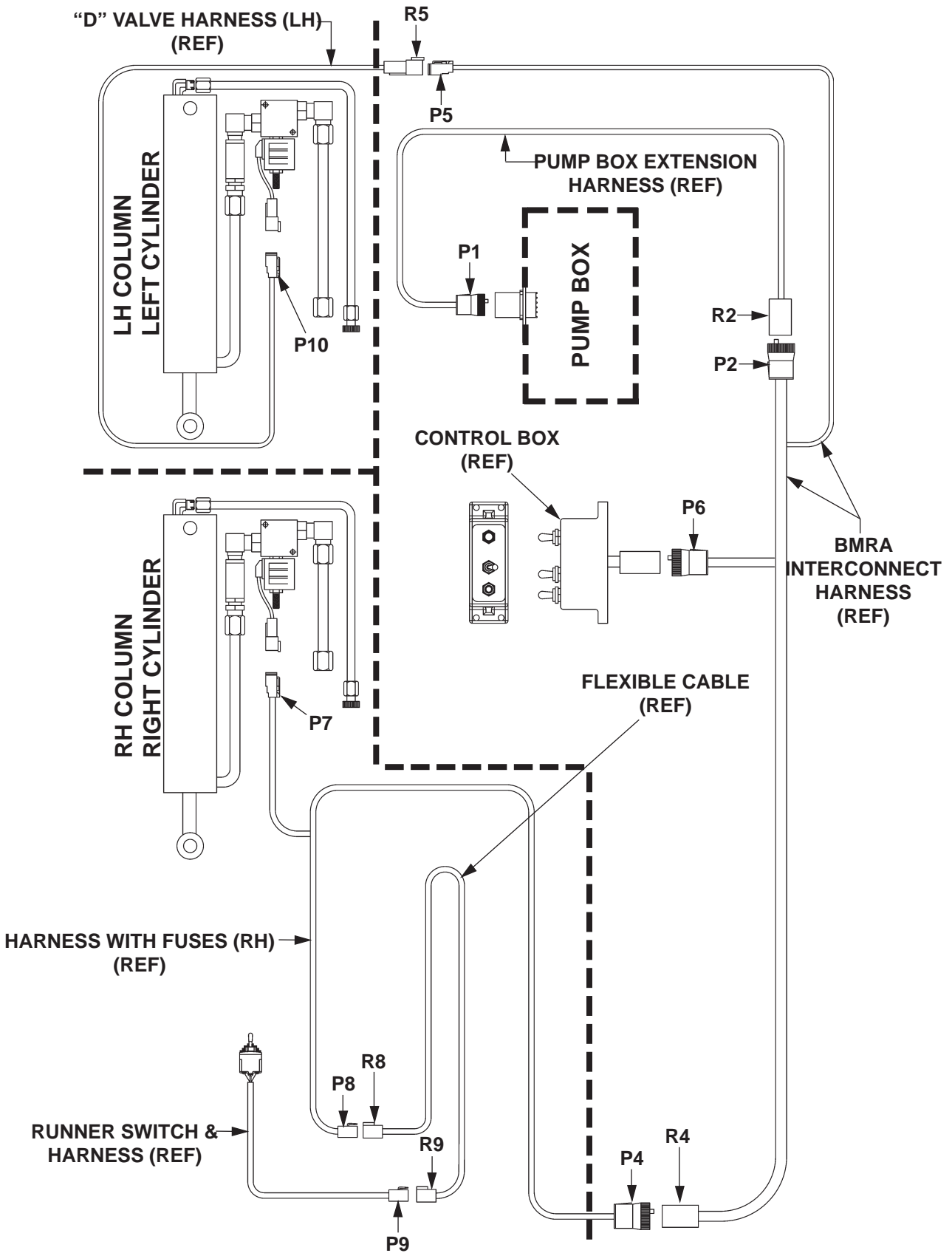

FIG. 47-1

TROUBLESHOOTING

PLATFORM WILL NOT RAISE, MOTOR WILL NOT RUN

NOTE: For dual pump system, check secondary pump and motor first.

1. Check for 12.6 volts dc input to motor solenoid by using voltmeter between terminal A (**FIG. 48-1**) and ground. If there is no power to the motor solenoid, make sure pump box master disconnect switch is **ON** and circuit breaker is set.

2. Find out if vehicle is equipped with optional battery box, truck charge line, tractor charge line, or trailer charge line. Check optional battery box cables and charge line cables for damage, dirty connections and loose connections. Replace damaged battery cables, clean dirty connections, and tighten loose connections.

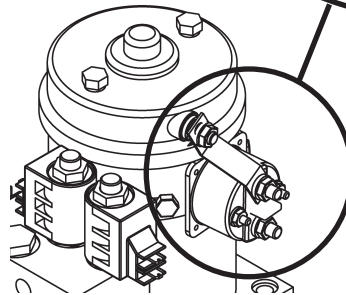
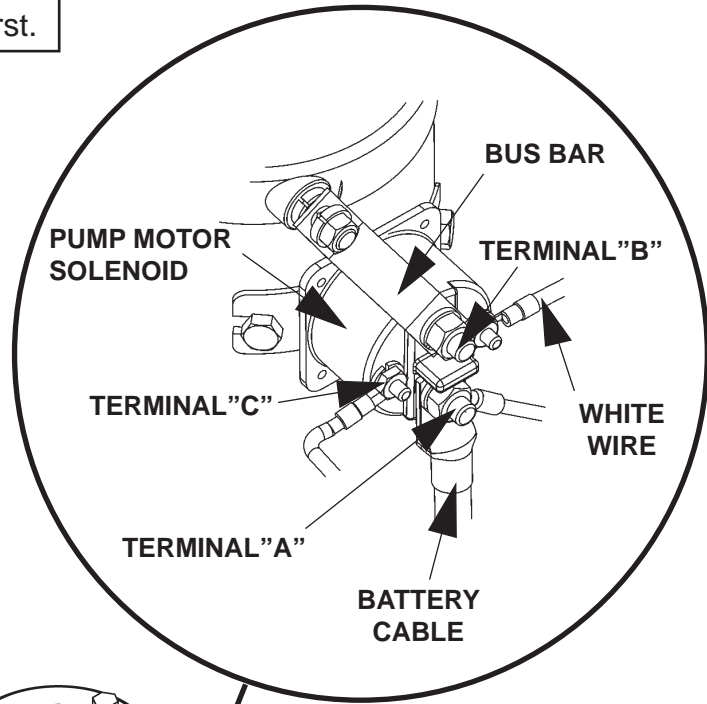

TYPICAL PUMP MOTOR SOLENOID
FIG. 48-1

3. Check if vehicle batteries and optional battery box batteries are fully charged. If required, fully charge batteries with a battery charger. Replace batteries that cannot be fully charged. If battery charger fully charges batteries, use vehicle manufacturer's specifications to check the vehicle battery charging system. Do not operate Liftgate if vehicle charging system needs repair.

4. Use a 6" long, 10 gauge insulated wire as a jumper to connect pump motor solenoid terminal A and terminal C. Check for 12.6 volts dc output from motor solenoid by using voltmeter between terminal B (**FIG. 48-1**) and ground. If a low voltage or 0 volts is indicated on terminal B, replace motor solenoid. Also, check bus bar for damage, dirty connections, and loose connections. Replace damaged bus bar, clean dirty connections, and tighten loose connections. Use multimeter and applicable schematics in this manual to check switch controls and interconnecting wiring.

MAXON

11921 Slauson Ave. Santa Fe Springs, CA. 90670 (800) 227-4116 FAX (888) 771-7713

PLATFORM WILL NOT PICK UP RATED CAPACITY

1. Check for unequal cylinder operation (lagging cylinder first).
 - **GRAVITY DOWN LIFTGATES:** Lower the platform to the ground. Disconnect the RETUN HOSE at the bottom of each column. Place a large container under cylinder to catch fluid. Set control box toggle switch to **UP** position to raise platform. Check if fluid is streaming from the fitting. A few drops of hydraulic fluid is okay; however, if fluid streams steadily from the fitting, replace piston seals.
 - **POWER DOWN LIFTGATES:** Raise the platform to bed height. Disconnect both bottom **POWER DOWN RETURN HOSES** at the “T” connector between pump box and bottom of each cylinder. Place a large container to catch fluid from both hoses. Set control box toggle switch to **UP** position to raise platform. Check if fluid is streaming from the hoses. A few drops of hydraulic fluid is okay; however, if fluid streams steadily from a hose, replace piston seals in the cylinder connected to that hose.
2. Check vehicle charge line cables for damage, dirty connections and loose connections. If Liftgate battery box is installed, check for damaged battery cables, dirty cable connections and loose cable connections in battery box. Replace damaged cables, clean dirty connections and tighten loose connections.
3. Check for bent parts on the Liftgate that could interfere with normal operation.

NOTE: For dual pump system, check secondary pump and motor first.

4. Verify that relief valve pressure settings are correct. Refer to relief valve pressure setting procedure. If pressure settings can't be corrected or if pump runs hot and excessively noisy, replace pump.

NOTE: Do the **BLEEDING HYDRAULIC SYSTEM** procedure in this manual with the following step.

5. Remove pump/motor assembly from reservoir (**FIG. 47-1**). Check if pump filter is clogged. Clean clogged filter and flush contaminated fluid from reservoir. Replace spin-on filter in pump box. Reinstall pump/motor assembly.

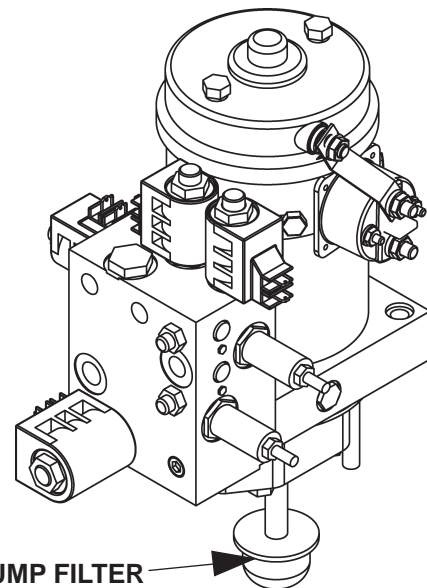

TYPICAL PUMP/MOTOR REMOVED TO CHECK AND CLEAN FILTER (POWER DOWN VERSION SHOWN)
FIG. 49-1

TROUBLESHOOTING PLATFORM RAISES HALFWAY & STOPS

1. Check the hydraulic fluid level in the reservoir.

- **GRAVITY DOWN LIFTGATES:** Lower the platform to the ground. Clean dirt and fluid from top of reservoir in pump box. Fill the reservoir to correct level indicated on sight glass (pump box).
- **POWER DOWN LIFTGATES:** Raise the platform to bed height. Fill the reservoir to correct level indicated on sight glass (pump box).

2. Find out if vehicle is equipped with optional battery box, truck charge line, tractor charge line, or trailer charge line. Check optional battery box cables and charge line cables for damage, dirty connections and loose connections. Replace damaged battery cables, clean dirty connections, and tighten loose connections.

3. Check if vehicle batteries and optional battery box batteries are fully charged. If required, fully charge batteries with a battery charger. Replace batteries that cannot fully charge. If battery charger fully charges batteries, use vehicle manufacturer's specifications to check the vehicle battery charging system. Do not operate Liftgate if vehicle charging system needs repair.

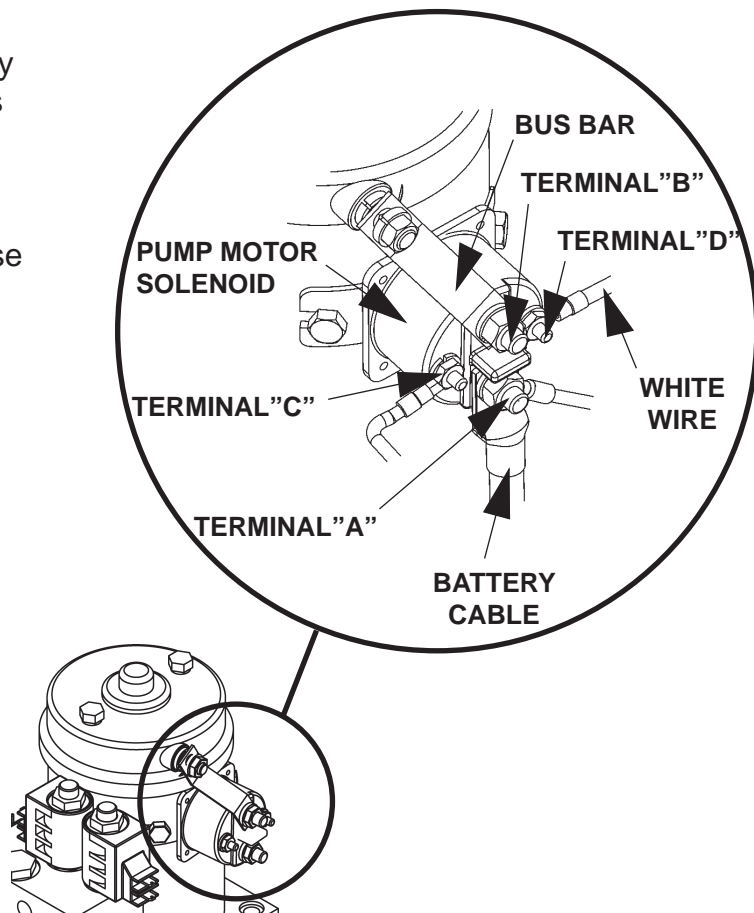

**TYPICAL PUMP MOTOR SOLENOID
FIG. 50-1**

NOTE: For dual pump system, check secondary pump and motor first.

4. Check pump motor solenoid (**FIG. 50-1**) and bus bar connections in pump box. Make sure bus bar connections are clean and tight. Use a 6" long, 10 gauge insulated wire as a jumper between motor solenoid terminals "C" and "D" to activate solenoid. Replace solenoid if it fails to activate.

5. Check for bent parts on the Liftgate that could interfere with normal operation.

NOTE: Do the **BLEEDING HYDRAULIC SYSTEM** procedure in this manual with the following step.

6. Remove assembled pump and motor from reservoir (**FIG. 51-1**). Check if pump filter is clogged. Clean clogged filter and flush contaminated fluid from reservoir. Replace spin-on filter in pump box.

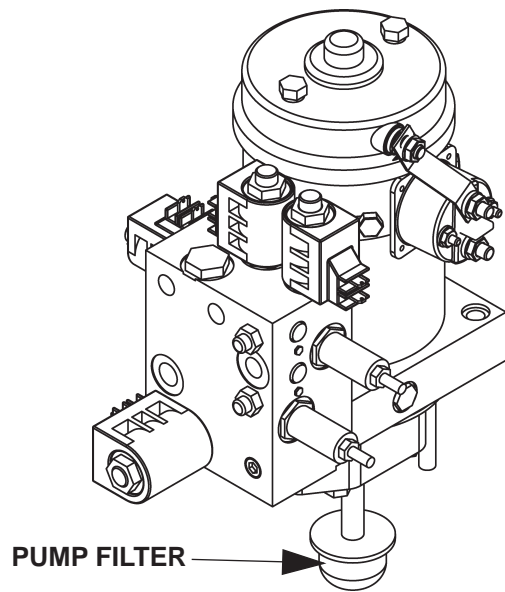

**TYPICAL PUMP/MOTOR REMOVED TO CHECK AND CLEAN FILTER (POWER DOWN VERSION SHOWN)
FIG. 51-1**

7. If pump runs hot and extremely noisy, replace it.

NOTE: Do the **BLEEDING HYDRAULIC SYSTEM** procedure in this manual with the following step.

8. Remove pressure compensation valve (**FIG. 51-2**) located at the top of each column. Check if the pressure compensation valves are contaminated. Disassemble, try to move plunger with small screwdriver, and then clean each valve as shown in **FIG. 51-2**. Reinstall or replace each valve if necessary.

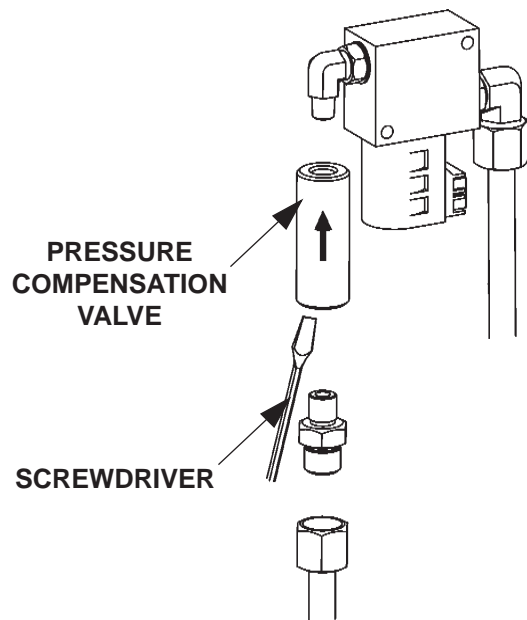

FIG. 51-2

TROUBLESHOOTING PLATFORM RAISES AND LOWERS UNEVENLY

NOTE: Do the **BLEEDING HYDRAULIC SYSTEM** procedure in this manual with the following step.

1. Reverse the two 3/8" high pressure hose connections on output side of flow divider as shown in **FIG. 52-1**. Raise the platform. If the uneven platform position is the opposite of original symptom, replace flow divider.

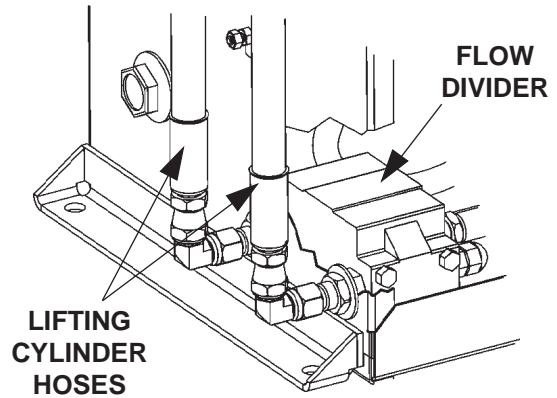

FIG. 52-1

2. Check each Lifting hydraulic cylinder.

- **GRAVITY DOWN LIFTGATES:** Lower the platform to the ground. Disconnect the RETURN HOSE from the bottom of each cylinder. Place a large container under each cylinder to catch fluid. Raise the platform. Check if fluid is streaming from the fitting. A few drops of hydraulic fluid is okay; however, if fluid streams steadily from the fitting, replace piston seals.
- **POWER DOWN LIFTGATES:** Raise the platform to bed height. Disconnect both bottom **POWER DOWN RETURN HOSES** at the "T" connector between pump box and bottom of each cylinder. Place a large container to catch fluid from both hoses. Raise the platform. Check if fluid is streaming from the hoses. A few drops of hydraulic fluid is okay; however, if fluid streams steadily from a hose, replace piston seals in the cylinder connected to that hose.

NOTE: Do the **BLEEDING HYDRAULIC SYSTEM** procedure in this manual with the following step.

3. Lower the platform to the ground and remove the pressure compensation valve (**FIG. 52-2**) located at the top of each column. Check if pressure compensation valves are contaminated. Disassemble, try to move plunger with small screwdriver, and then clean each valve if required (**FIG. 52-2**). Reinstall or replace each valve if necessary.

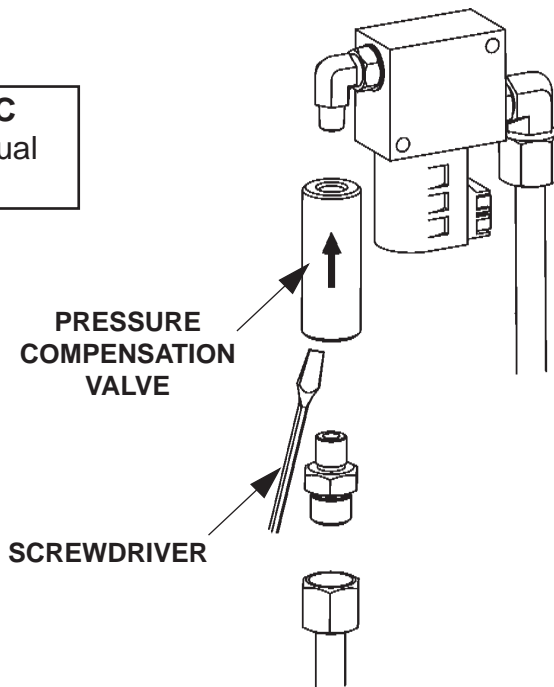

FIG. 52-2

4. Check for bent parts on the Liftgate that could interfere with normal operation.

PLATFORM WILL NOT FOLD

1. Check the hydraulic fluid level in the reservoir.

- **GRAVITY DOWN LIFTGATES:** Lower the platform to the ground. Clean dirt and fluid from top of reservoir in pump box. Fill the reservoir to correct level indicated on sight glass (pump box).
- **POWER DOWN LIFTGATES:** Raise the platform to bed height. Fill the reservoir to correct level indicated on sight glass (pump box).

NOTE: For dual pump system, check secondary pump and motor first.

2. Check pump motor solenoid (**FIG. 53-1**) in pump box and bus bar connections in pump box. Make sure bus bar connections are clean and tight. Use a 6" long, 10 gauge insulated wire as a jumper between motor solenoid terminals "C" and "A" to activate solenoid. Replace solenoid if it fails to activate.

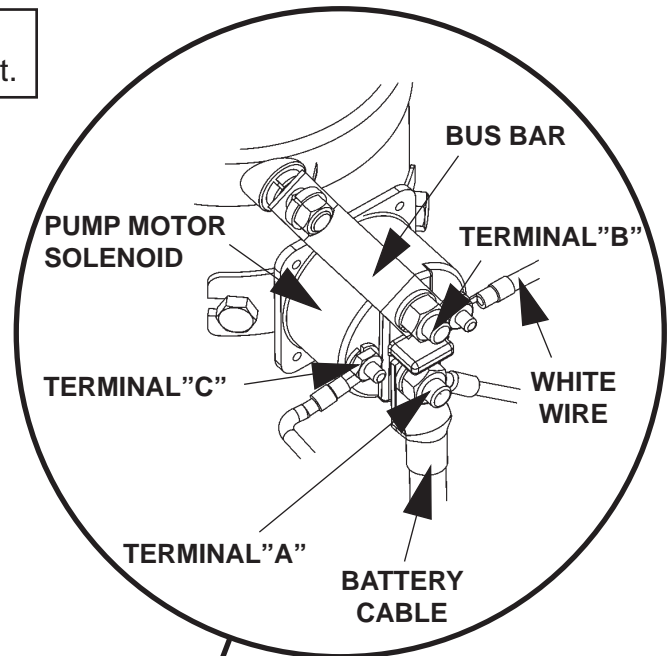

3. Verify that relief valve pressure settings are correct. Refer to **RELIEF VALVE PRESSURE SETTING** procedure in this manual. Also, make sure flow control valve (on pump) is open. Perform platform opening & closing speed adjustment procedure. If pressure settings can't be corrected, if platform opening and closing speed can't be adjusted or if pump runs hot and excessively noisy, replace pump.

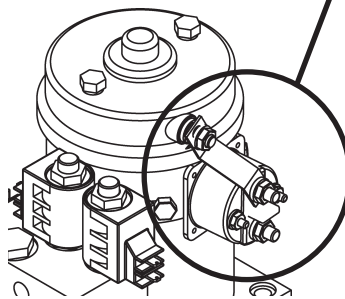

**TYPICAL PUMP MOTOR SOLENOID
FIG. 53-1**

TROUBLESHOOTING

PLATFORM WILL NOT FOLD - Continued

⚠ WARNING

Make sure Liftgate platform is open and resting on the ground before performing the following step.

4. Check the “E” valve (**FIG. 54-1**) stem by removing the coil assembly (**ITEM 1, FIG. 54-2**). Unscrew the valve stem (**ITEM 2, FIG. 54-2**) from the pump. Push on the plunger, located inside the valve stem, with a small screwdriver. If the plunger does not move freely (approximately 1/8”), clean it. If the plunger does not move freely after cleaning, replace the valve stem.

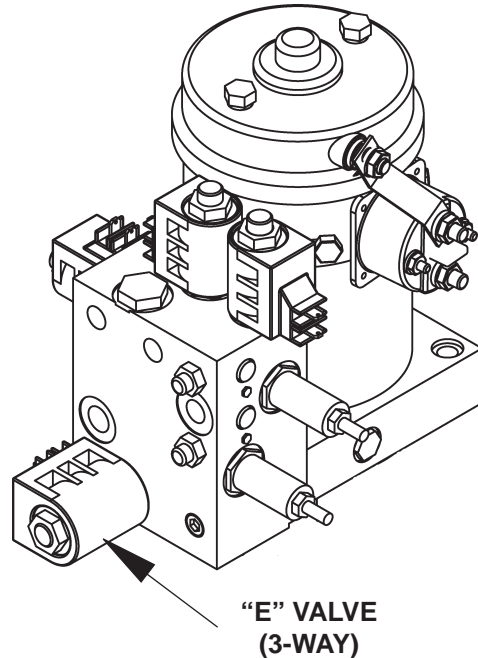

**TYPICAL PUMP/MOTOR SOLENOID VALVES
(POWER DOWN VERSION SHOWN)**

FIG. 54-1

5. Check for bent parts on the Liftgate that could interfere with normal operation.
6. Check if hydraulic fluid is streaming from breather plug.

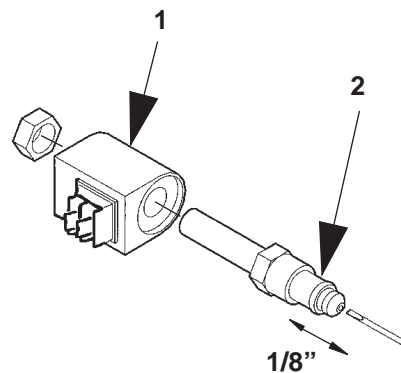

**TYPICAL SOLENOID VALVE
SHOWN DISASSEMBLED**

FIG. 54-2

MAXON

11921 Slauson Ave. Santa Fe Springs, CA 90670 (800) 227-4116 FAX (888) 771-7713

PLATFORM WILL NOT UNFOLD

⚠ WARNING

Before doing the following procedure, set up guarded area around the platform to keep people from entering.

NOTE: For dual pump system, check secondary pump and motor first.

1. Flow of hydraulic fluid may be restricted. Turn opener valve adjustment (**FIG. 55-1**) counter-clockwise to open the valve. If necessary, do the **PUMP ASSEMBLY PRESSURE SETTING** procedure in this section.

NOTE: Numbers for the electrical terminals are not stamped on the valve coil. Numbers shown in illustration are for reference only.

2. Check if the “A” valve (**FIG. 55-1**) is energized. Connect voltmeter to Terminal-1 and Terminal-2 as shown in **FIG. 55-1**. Activate the **UNFOLD** toggle switch and **FOLD/UNFOLD** toggle switches. Correct indication is +11 to +12.6 volts dc. If indication is incorrect, check control switch and wiring to “A” valve (refer to **ELECTRICAL SYSTEM DIAGRAMS** section). Replace faulty wiring or control switch as required. If the voltmeter indicates +11 to +12.6 volts dc and “A” valve does not operate, replace “A” valve.

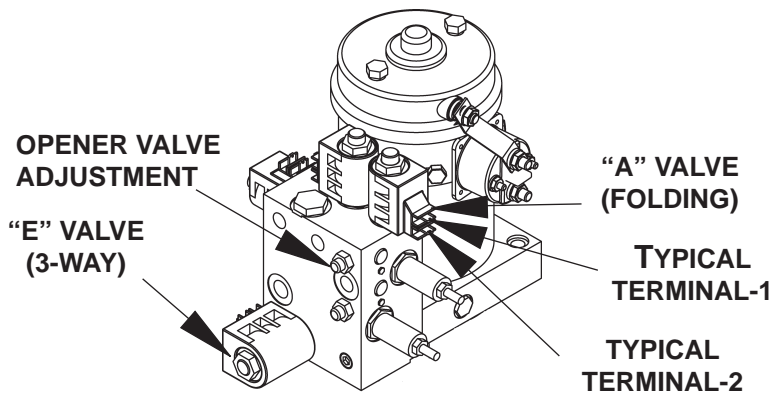

TYPICAL PUMP/MOTOR VALVES & ELECTRICAL CONNECTIONS (POWER DOWN VERSION SHOWN)
FIG. 55-1

3. Check the “E” valve (**FIG. 55-1**) stem by removing the coil assembly (**ITEM 1, FIG. 55-2**). With platform supported, unscrew the valve stem (**ITEM 2, FIG. 55-2**) from the pump. Push on the plunger, located inside the valve stem, with a small screwdriver. If the plunger does not move freely (approximately 1/8”), clean it. If it does not move freely after cleaning, replace the valve stem.

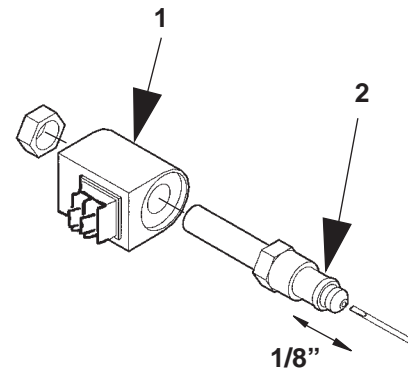

TYPICAL SOLENOID VALVE SHOWN DISASSEMBLED
FIG. 55-2

TROUBLESHOOTING

PLATFORM WILL NOT UNFOLD - Continued

4. Check for damage and corrosion at platform pivot points. Steam clean corrosion from pivot points. Replace bushings at pivot points if required.

5. Check for bent and broken parts on the Liftgate that could interfere with normal operation. Look at columns, runners, tandem rollers and platform (bent pins).

6. Check for weak platform torsion spring. Replace if necessary.

MAXON[®]

11921 Slauson Ave. Santa Fe Springs, CA. 90670 (800) 227-4116 FAX (888) 771-7713

PUMP ASSEMBLY PRESSURE SETTING

The pump pressure is set at the factory; however, if adjustment is needed, use the following procedure.

1. Open the platform. Turn closer valve adjustment (**FIG. 57-1**) all the way clockwise. Disconnect hose from folding port bulkhead fitting and connect 0-3000 PSI gauge to hose (**FIG. 57-1**).

2. Remove plug (covering pump pressure relief valve) from pump block (**FIG. 57-2**). Set Liftgate control box to **FOLD**. Turn the pump pressure relief valve (**FIG. 57-2**) to obtain proper pump pressure setting of **2750 PSI**. Re-install plug.

3. If this is a dual pump system, do the following. Once pump 1 is set, select pump 2 with pump select switch (**FIG. 57-2**). Repeat **Steps 1 and 2** for pump 2.

4. Disconnect 0-3000 PSI gauge from hose (**FIG. 57-1**) and reconnect hose to folding port bulkhead fitting.

5. Reset the closer valve adjustment (**FIG. 57-2**) to obtain platform closing speed cycle of 4-6 seconds.

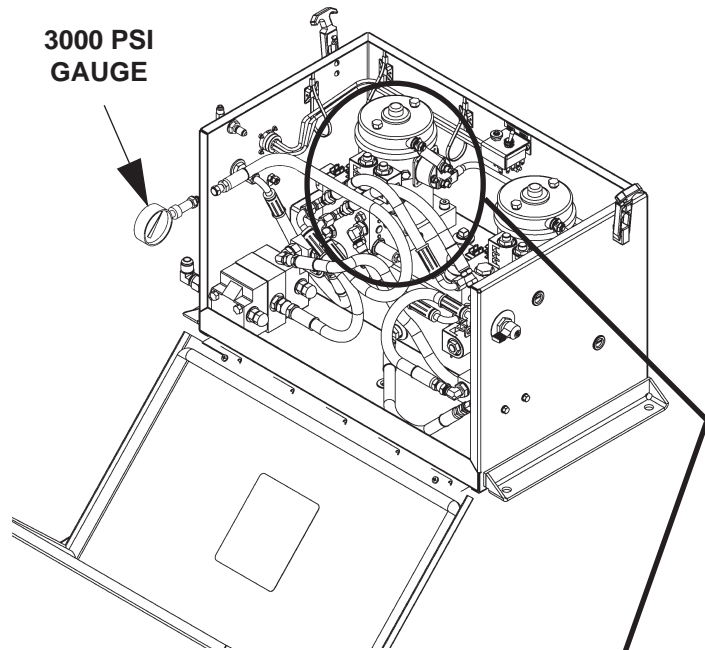

CONNECTING PRESSURE GAUGE -
DUAL PUMP SHOWN
FIG. 57-1

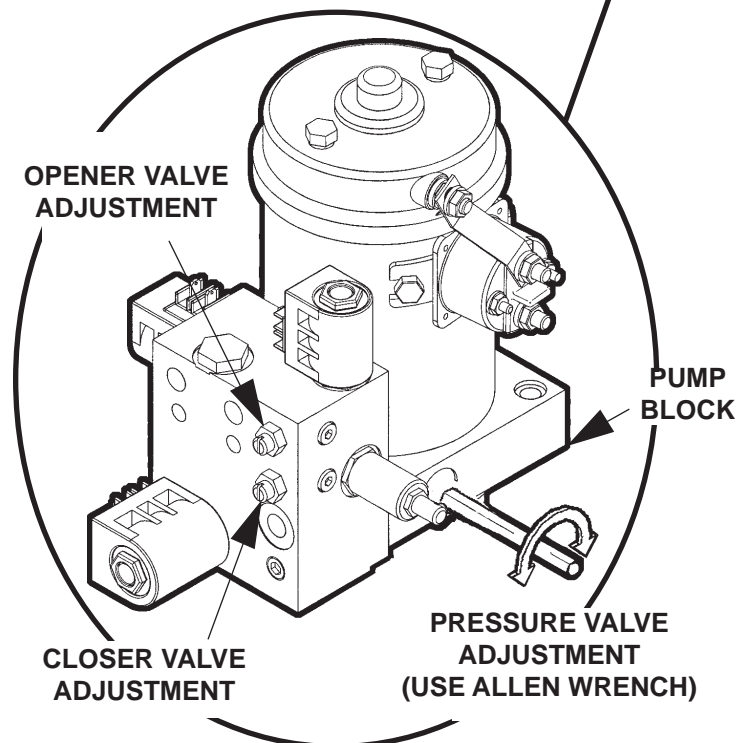

FIG. 57-2

TROUBLESHOOTING

RELIEF VALVE PRESSURE SETTING

NOTE: The relief valve pressure is set at the factory; however, if adjustment is needed, use the following procedure to set the pressure. At first, adjust pressure to **2100 PSI**. Then slowly adjust pressure up to correct reading.

Attach a 0-3000 PSI gauge, with thread adapter and swivel adapter, to pump pressure port as shown in **FIG. 58-1** and **FIG. 58-2**. Use **UP/DOWN** toggle switch in **UP** position to run pump motor. Turn the relief valve to **2400 PSI**.

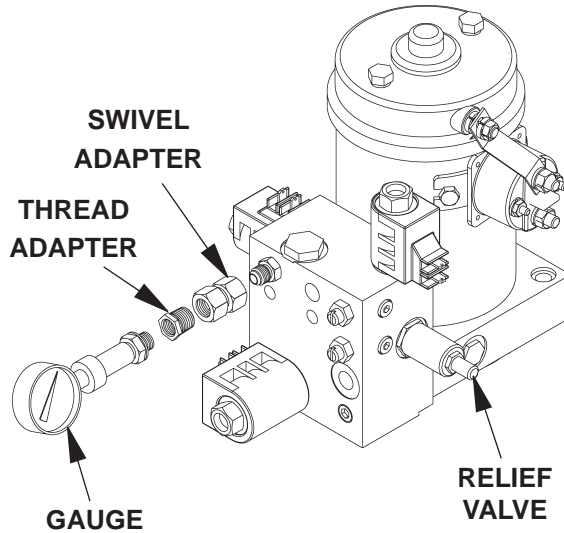

GRAVITY DOWN PUMP/MOTOR
FIG. 58-1

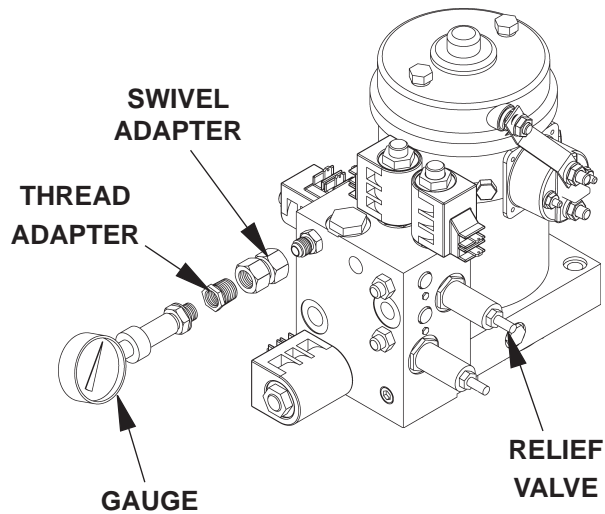

POWER DOWN PUMP/MOTOR
FIG. 58-2

MAXON[®]

11921 Slauson Ave. Santa Fe Springs, CA. 90670 (800) 227-4116 FAX (888) 771-7713

TROUBLESHOOTING - GRAVITY DOWN PLATFORM WILL NOT RAISE, MOTOR RUNS

1. Check the hydraulic fluid level in the reservoir.
 - **GRAVITY DOWN LIFTGATES:** Lower the platform to the ground. Clean dirt and fluid from top of reservoir in pump box. Fill the reservoir to correct level indicated on sight glass (pump box).
 - **POWER DOWN LIFTGATES:** Raise the platform to bed height. Fill the reservoir to correct level indicated on sight glass (pump box).
2. Check for bent parts on the Liftgate that could interfere with normal operation. Look at columns, runners, and tandem rollers.

⚠ WARNING

Make sure Liftgate platform is open and resting on the ground before performing the following step.

NOTE: For dual pump system, check secondary pump and motor first.

3. Check the high pressure relief valve (**FIG. 59-1**) for contamination or defective operation. Lower the platform to the ground. Remove the relief valve. Clean or replace valve as required.

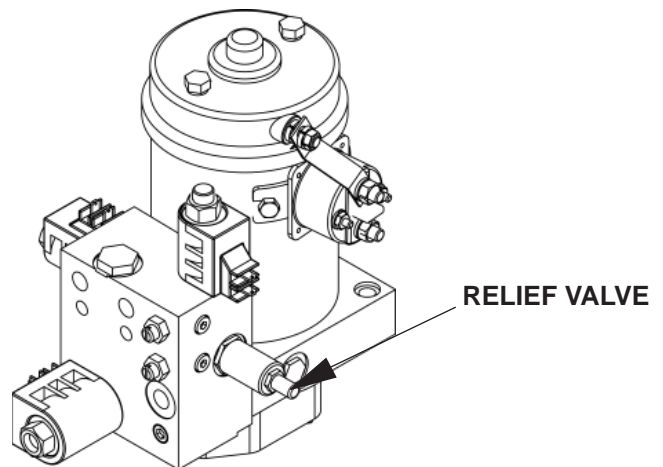

**GRAVITY DOWN PUMP/MOTOR
RELIEF VALVE LOCATION
FIG. 59-1**

4. Adjust relief valve operating pressure according to **RELIEF VALVE PRESSURE SETTING** procedure.

TROUBLESHOOTING - GRAVITY DOWN PLATFORM WILL NOT LOWER

NOTE: For dual pump system, check secondary pump and motor first.

NOTE: Numbers for the electrical terminals shown in the illustration are not stamped on valve coil. Numbers shown are for reference only.

1. Try lowering platform (activate **DOWN** toggle switch). Only the motor solenoid and "B" valve (both located in the pump box) (**FIG. 60-1**) and "D" valve (on top of LH and RH columns) (**FIG. 60-2**) should be energized while lowering platform. Connect voltmeter to Terminal-1 and Terminal-2 on each valve shown in **FIG. 60-1**. Correct indication for "B" and "D" valves is +11 to +12.6 volts dc. If indications are incorrect, check control switch and wiring to that valve (refer to **ELECTRICAL SYSTEM DIAGRAMS** section). Replace faulty wiring or control switch as required.

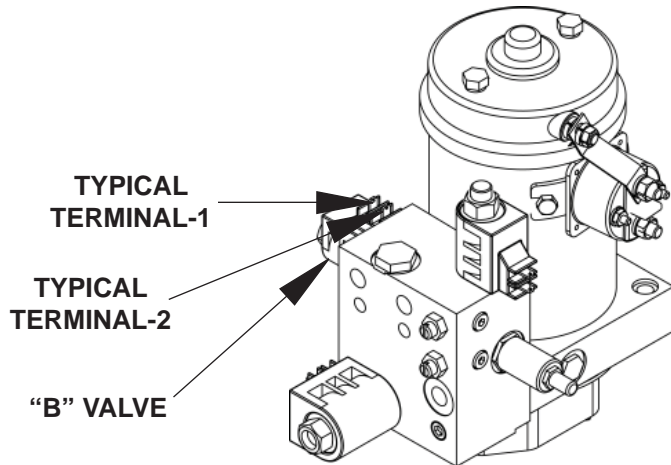

**GRAVITY DOWN PUMP/MOTOR VALVE &
ELECTRICAL CONNECTIONS
FIG. 60-1**

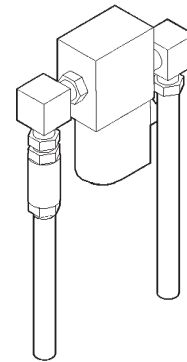

**"D" VALVE
FIG. 60-2**

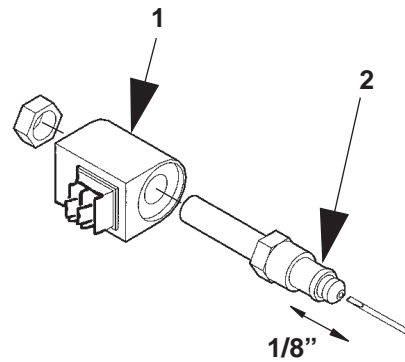

**TYPICAL SOLENOID VALVE
SHOWN DISASSEMBLED
FIG. 60-3**

⚠ WARNING
Make sure Liftgate platform is open and resting on the ground before performing the following step.

2. Check valve stems (**FIG. 60-3**) by removing from the coil assembly (**ITEM 1, FIG. 60-3**). With platform supported, unscrew the valve stem (**ITEM 2, FIG. 60-3**) from the pump. Push on the plunger, located inside the valve stem, with a small screwdriver. If the plunger does not move freely (approximately 1/8") clean it. If the plunger does not move freely after cleaning, replace the valve stem.

MAXON

11921 Slauson Ave. Santa Fe Springs, CA. 90670 (800) 227-4116 FAX (888) 771-7713

PLATFORM LOWERS SLOWLY

NOTE: For dual pump system, check secondary pump and motor first.

NOTE: Numbers for the electrical terminals shown in the illustration are not stamped on valve coil. Numbers shown are for reference only.

1. Check if the “B” valve coil (**FIG. 61-1**) (located in the pump box) is getting power. Connect voltmeter to Terminal-1 and Terminal-2 shown in **FIG. 61-1**. Activate the **DOWN** toggle switch. Correct indication is +11 to +12.6 volts dc. If the voltmeter does not indicate +11 to +12.6 volts dc, check control switch and wiring to “B” valve (refer to **ELECTRICAL SYSTEM DIAGRAMS** section). Replace faulty wiring or control switch as required. If the voltmeter indicates +11 to +12.6 volts dc and valve still does not operate, replace the valve.

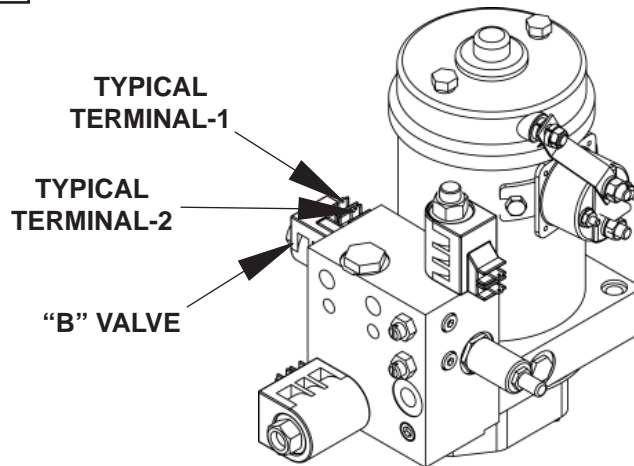

**GRAVITY DOWN PUMP/MOTOR VALVE
& ELECTRICAL CONNECTIONS
FIG. 61-1**

⚠ WARNING

Make sure Liftgate platform is open and resting on the ground before performing the following step.

2. Check the valve stem (**FIG. 61-2**) by removing the coil assembly (**ITEM 1, FIG. 61-2**). With platform supported, unscrew the valve stem (**ITEM 2, FIG. 61-2**) from the pump. Push on the plunger, located inside the valve stem, with a small screwdriver. If the plunger does not move freely (approximately 1/8”), clean it. If plunger does not move freely after cleaning, replace the valve stem.
3. Check the pressure compensation valves (see **PLATFORM RAISES AND LOWERS UNEVEN**).
4. Check for bent and broken parts on the Liftgate that could interfere with normal operation.

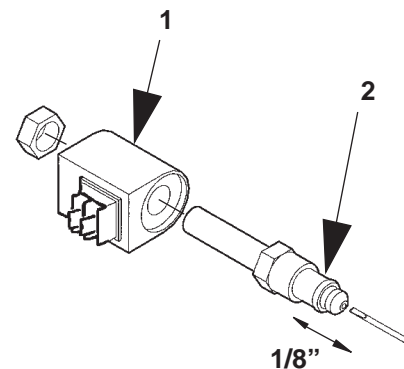

**TYPICAL SOLENOID VALVE
SHOWN DISASSEMBLED
FIG. 61-2**

TROUBLESHOOTING - POWER DOWN PLATFORM WILL NOT RAISE, MOTOR RUNS

1. Check the hydraulic fluid level in the reservoir.

- **GRAVITY DOWN LIFTGATES:** Lower the platform to the ground. Clean dirt and fluid from top of reservoir in pump box. Fill the reservoir to correct level indicated on sight glass (pump box).
- **POWER DOWN LIFTGATES:** Raise the platform to bed height. Fill the reservoir to correct level indicated on sight glass (pump box).

NOTE: For dual pump system, check secondary pump and motor first.

NOTE: Numbers for the electrical terminals shown in the illustration are not stamped on valve coil. Numbers shown are for reference only.

2. Try raising platform (activate **UP** toggle switch). Only the motor solenoid (**FIG. 62-1**) should be energized while raising platform. The "A", "B", "C" and "E" valves (**FIG. 62-1**) (located in the pump box) should not be energized.

Connect voltmeter to Terminal-1 and Terminal-2 on each valve shown in **FIG. 62-1**. Correct indication is 0 volts dc. If voltmeter indicates +11 to +12.6 volts dc for any of the valves, check control switch and wiring to the valve (refer to **ELECTRICAL SYSTEM DIAGRAMS** section). Replace faulty wiring or control switch as required.

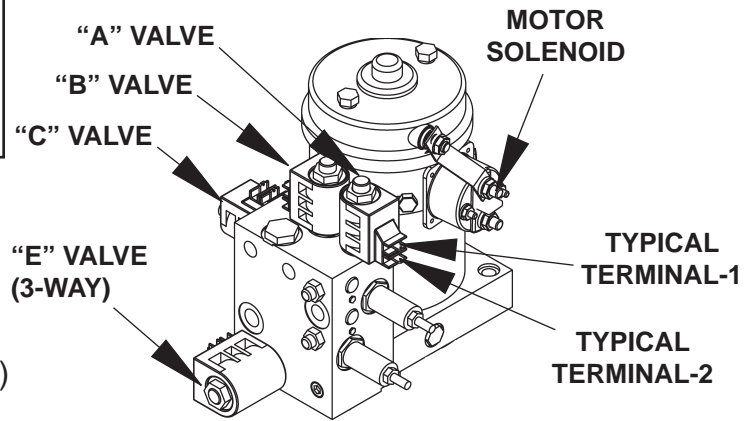

**POWER DOWN PUMP/MOTOR VALVES &
ELECTRICAL CONNECTIONS
FIG. 62-1**

⚠ WARNING

Make sure Liftgate platform is open and resting on the ground before performing the following step.

3. The "E" valve solenoid may be stuck in the "open" position. Check solenoid valve stem (**FIG. 62-2**) by removing the coil assembly (**ITEM 1, FIG. 62-2**). With platform supported, unscrew the valve stem (**ITEM 2, FIG. 62-2**) from the pump. Push on the plunger, located inside the valve stem, with a small screwdriver. If the plunger does not move freely (approximately 1/8"), clean it. If it does not move freely after cleaning, replace the valve stem.
4. Check for bent and broken parts on the Liftgate that could interfere with normal operation.

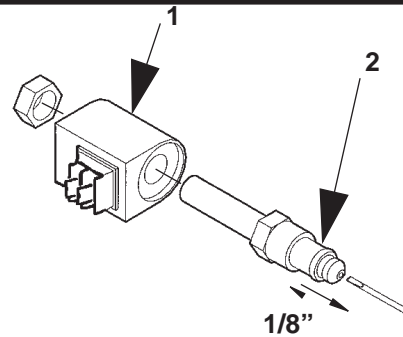

**TYPICAL SOLENOID VALVE
SHOWN DISASSEMBLED
FIG. 62-2**

PLATFORM WILL NOT LOWER

NOTE: For dual pump system, check secondary pump and motor first.

NOTE: Numbers for the electrical terminals shown in the illustration are not stamped on valve coil. Numbers shown are for reference only.

1. Try lowering platform (activate **DOWN** toggle switch). Only the motor solenoid, "B" valve and "C" valve (located in the pump box) (**FIG. 63-1**) and "D" valve (on top of LH and RH columns) (**FIG. 63-2**) should be energized while lowering platform. The "A" and "E" valves should not be energized. Connect voltmeter to Terminal-1 and Terminal-2 on each valve shown in **FIG. 63-1**. Correct indication for "A" and "E" valves is 0 volts dc. For "B", "C" and "D" valves correct indication is +11 to +12.6 volts dc. If any indications are incorrect, check control switch and wiring to that valve (refer to **ELECTRICAL SYSTEM DIAGRAMS** section). Replace faulty wiring or control switch as required.

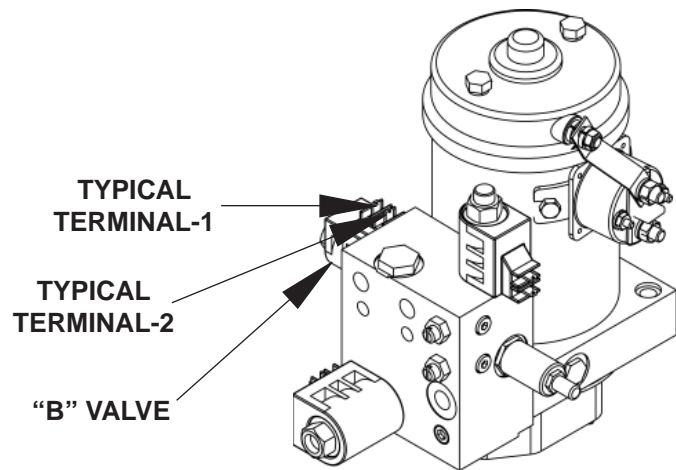

GRAVITY DOWN PUMP/MOTOR VALVE & ELECTRICAL CONNECTIONS
FIG. 63-1

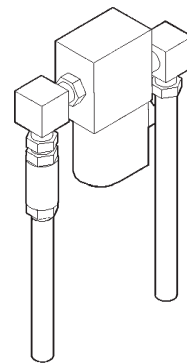

"D" VALVE
FIG. 63-2

⚠ WARNING

Make sure Liftgate platform is open and resting on the ground before performing the following step.

2. Check valve stems (**FIG. 63-3**) by removing from the coil assembly (**ITEM 1, FIG. 63-3**). With platform supported, unscrew the valve stem (**ITEM 2, FIG. 63-3**) from the pump. Push on the plunger, located inside the valve stem, with a small screwdriver. If the plunger does not move freely (approximately 1/8") clean it. If the plunger does not move freely after cleaning, replace the valve stem.

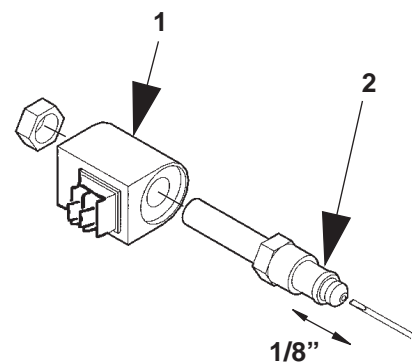

TYPICAL SOLENOID VALVE SHOWN DISASSEMBLED
FIG. 63-3

TROUBLESHOOTING - POWER DOWN PLATFORM LOWERS SLOWLY

NOTE: For dual pump system, check secondary pump and motor first.

NOTE: Numbers for the electrical terminals shown in the illustration are not stamped on valve coil. Numbers shown are for reference only.

1. Try lowering platform (activate **DOWN** toggle switch). Make sure motor solenoid (located in the pump box) (**FIG. 64-1**) is energized and "E" valve is not energized while lowering platform. Connect voltmeter to Terminal-1 and Terminal-2 on "E" valve shown in **FIG. 64-1**. The correct indication on voltmeter is 0 volts dc when "E" valve is not energized. If the voltmeter indicates +11 to +12.6 volts dc, check control switch and wiring to that valve (refer to **ELECTRICAL SYSTEM DIAGRAMS** section). Replace faulty wiring or control switch as required.

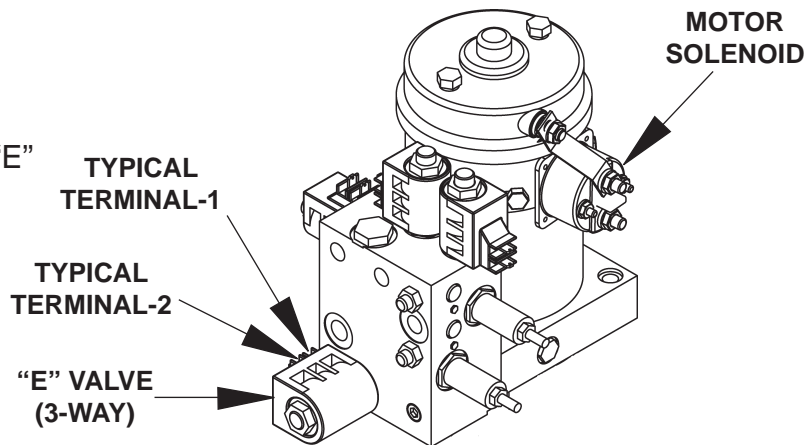

**POWER DOWN PUMP/MOTOR VALVES &
ELECTRICAL CONNECTIONS**
FIG. 64-1

⚠ WARNING

Make sure Liftgate platform is open and resting on the ground before performing the following step.

2. Check solenoid valve stems (**FIG. 64-2**) by removing the coil assembly (**ITEM 1, FIG. 64-2**). With platform supported, unscrew the valve stem (**ITEM 2, FIG. 64-2**) from the pump. Push on the plunger, located inside the valve stem, with a small screwdriver. If the plunger does not move freely (approximately 1/8"), clean it. If plunger does not move freely after cleaning, replace the valve stem.
4. Check for bent and broken parts on the Liftgate that could interfere with normal operation.
5. Check the pressure compensation valves (see **PLATFORM RAISES AND LOWERS UNEVEN**).

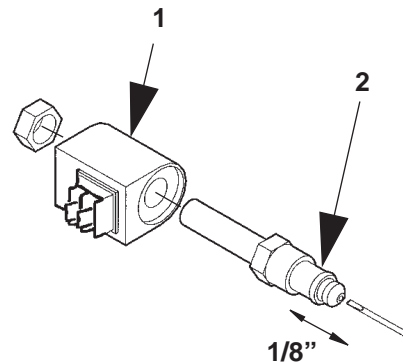

**TYPICAL SOLENOID VALVE
SHOWN DISASSEMBLED**
FIG. 64-2

