

M-04-04
REV. A
FEBURARY 2005

MAXON®

MAINTENANCE MANUAL

GPTLR-25 & GPTLR-33

TUK-A-WAY®
LIFT GATE SERIES

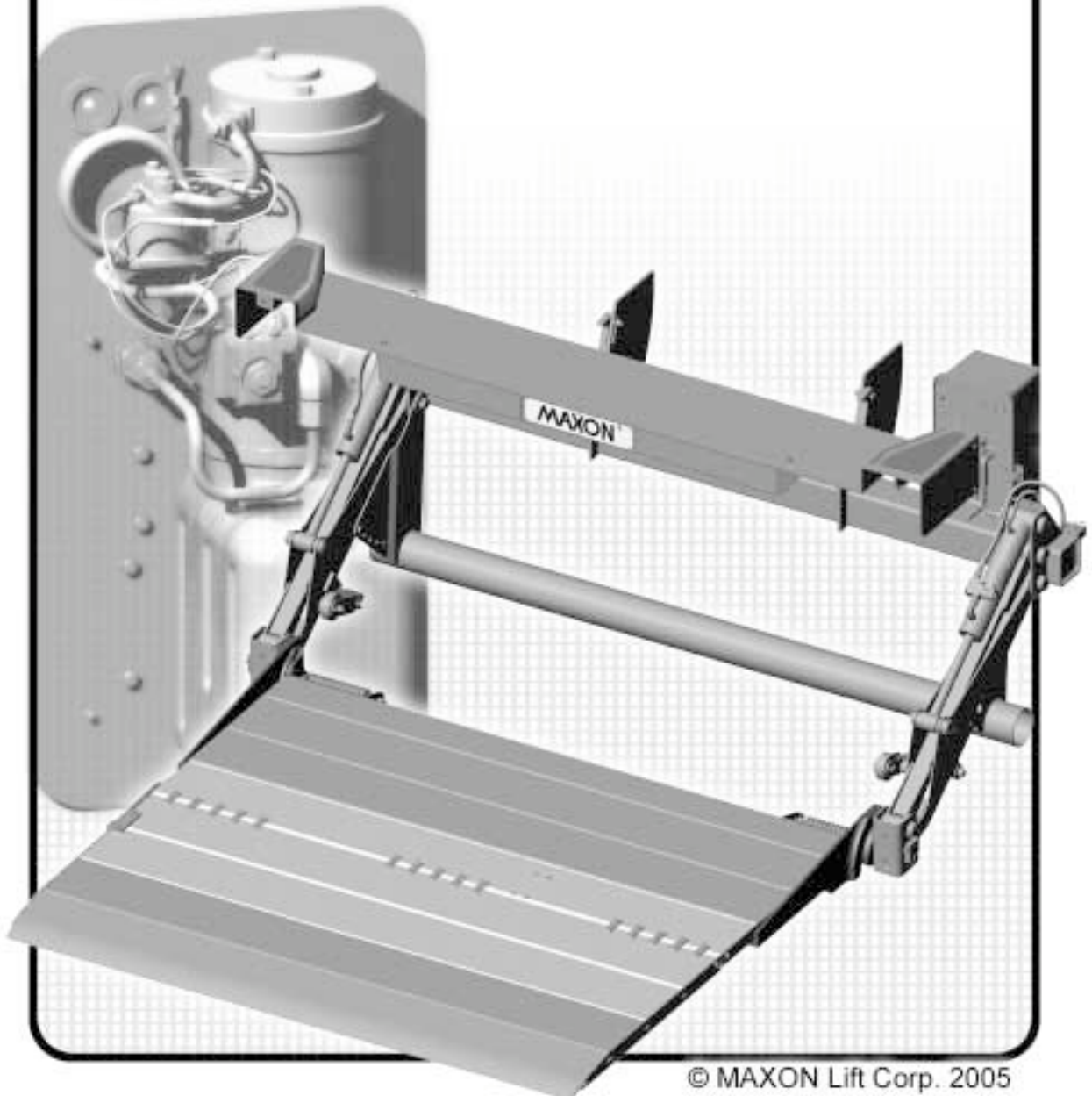

© MAXON Lift Corp. 2005

MAXON[®]

LIFT CORP.

11921 Slauson Ave.
Santa Fe Springs, CA. 90670

CUSTOMER SERVICE:
TELEPHONE (562) 464-0099 TOLL FREE (800) 227-4116
FAX: (888) 771-7713

NOTE: For latest version of all Manuals (and replacements), download the Manuals from Maxon's website at www.maxonlift.com.

WARRANTY/ RMA POLICY & PROCEDURE

LIFTGATE WARRANTY

Type of Warranty: Full Parts and Labor

Term of Warranty: Standard Liftgates - 2 years from ship date or 6,000 cycles
Premium Liftgates - 2 years from ship date or 10,000 cycles

This warranty shall not apply unless the product is installed, operated and maintained in accordance with MAXON Lift's specifications as set forth in MAXON Lift's Installation, Operation and Maintenance manuals. This warranty does not cover normal wear, maintenance or adjustments, damage or malfunction caused by improper handling, installation, abuse, misuse, negligence, or carelessness of operation. In addition, this warranty does not cover equipment that has had unauthorized modifications or alterations made to the product.

MAXON agrees to replace any components which are found to be defective during the first 2 years of service, and will reimburse for labor based on MAXON's Liftgate Warranty Flat Rate Schedule. (Copy of the Flat Rate is available at www.maxonlift.com.)

All warranty repairs must be performed by an authorized MAXON warranty facility. For any repairs that may exceed \$500, including parts and labor, MAXON's Technical Service Department must be notified and an "Authorization Number" obtained.

All claims for warranty must be received within 30 Days of the repair date, and include the following information:

1. Liftgate Model Number and Serial Number
2. The End User must be referenced on the claim
3. Detailed Description of Problem
4. Corrective Action Taken, and Date of Repair
5. Parts used for Repair, Including MAXON Part Number(s)
6. MAXON R.M.A. # and/or Authorization # if applicable (see below)
7. Person contacted at MAXON if applicable
8. Claim must show detailed information i.e. Labor rate and hours of work performed

Warranty claims can also be placed on-line at www.maxonlift.com. On-line claims will be given priority processing.

All claims for warranty will be denied if paperwork has not been received or claim submitted via Maxon website for processing by MAXON's Warranty Department within 30 days of repair date.

All components may be subject to return for inspection, prior to the claim being processed. MAXON products may not be returned without prior written approval from MAXON's Technical Service Department. Returns must be accompanied by a copy of the original invoice or reference with original invoice number and are subject to a credit deduction to cover handling charges and any necessary reconditioning costs. **Unauthorized returns will be refused and will become the responsibility of the returnee.**

Any goods being returned to MAXON Lift must be pre-approved for return, and have the R.M.A. number written on the outside of the package in plain view, and returned freight prepaid. All returns are subject to a 15% handling charge if not accompanied by a detailed packing list. Returned parts are subject to no credit and returned back to the customer.

Defective Parts requested for return must be returned within 30 days of the claim date for consideration to:

MAXON Lift Corp.
16205 Distribution Way, Cerritos, CA 90703
Attn: RMA#___

MAXON's warranty policy does not include the reimbursement for travel time, towing, vehicle rental, service calls, oil, batteries or loss of income due to downtime. Fabrication or use of non Maxon parts, which are available from MAXON, are also not covered.

MAXON's Flat Rate Labor Schedule takes into consideration the time required for diagnosis of a problem.

All Liftgates returned are subject to inspection and a 15% restocking fee. Any returned Liftgates or components that have been installed or not returned in new condition will be subject to an additional reworking charge which will be based upon the labor and material cost required to return the Liftgate or component to new condition.

PURCHASE PART WARRANTY

Term of Warranty: 1 Year from Date of Purchase.

Type of Warranty: Part replacement only

MAXON will guarantee all returned genuine MAXON replacement parts upon receipt and inspection of parts and original invoice.

All warranty replacements parts will be sent out via ground freight. If a Rush Shipment is requested all freight charges will be billed to the requesting party.

TABLE OF CONTENTS

WARNINGS	6
LIFTGATE TERMINOLOGY	7
PERIODIC MAINTENANCE	8
PERIODIC MAINTENANCE CHECKLIST	8
CHECKING HYDRAULIC FLUID	10
CHANGING HYDRAULIC FLUID	12
REPLACING PLATFORM TORSION SPRING	14
PARTS BREAKDOWN	15
GPT MAIN ASSEMBLY (ALUMINUM PLATFORM)	16
GPT MAIN ASSEMBLY (STEEL PLATFORM)	18
MAIN FRAME, LIFTING ARMS, & PARALLEL ARMS GPTLR-25 & GPTLR-33	20
PLATFORM & FLIPOVER ASSEMBLY (ALUMINUM)	22
PLATFORM WITH DUAL CART STOP & FLIPOVER ASSEMBLY (ALUMINUM)	24
FLIPOVER WITH DUAL CART STOPS (ALUMINUM)	26
PLATFORM & FLIPOVER ASSEMBLY (STEEL)	28
PUMP COVER & MOUNTING PLATE ASSEMBLY	29
GRAVITY DOWN HYDRAULIC COMPONENTS	30
12 VDC POWER UNIT (GRAVITY DOWN)	31
POWER DOWN HYDRAULIC COMPONENTS	32
12 VDC POWER UNIT (POWER DOWN)	33
DECALS	34
NONSKID & SAFETY STRIPING	36
CONTROL SWITCH AND POWER CABLE	37

HYDRAULIC SYSTEM DIAGRAMS	38
HYDRAULIC SCHEMATIC (GRAVITY DOWN)	38
HYDRAULIC SCHEMATIC (POWER DOWN)	39
ELECTRICAL SYSTEM DIAGRAMS	40
ELECTRICAL SCHEMATIC (GRAVITY DOWN)	40
ELECTRICAL SCHEMATIC (POWER DOWN)	41
RECOMMENDED BOLT TORQUES.....	42
TROUBLESHOOTING	43
PLATFORM WILL NOT RAISE	43
PLATFORM RAISES BUT LEAKS DOWN.....	44
PLATFORM RAISES PARTIALLY AND STOPS	45
LIFTGATE WILL NOT LIFT RATED CAPACITY	46
PLATFORM RAISES SLOWLY	47
PLATFORM WILL NOT LOWER, LOWERS TOO SLOWLY, OR LOWERS TOO QUICKLY ..	48

Comply with the following **WARNINGS** while maintaining Liftgates. See Operation Manual M-04-05 for operating safety requirements.

WARNING

- Read and understand the instructions in this **Maintenance Manual** before performing maintenance on the Liftgate.
- Before operating the Liftgate, read and understand the operating instructions in **Operation Manual M-04-05**.
- Comply with all **WARNING** and instruction decals attached to the Liftgate.
- Keep decals clean and legible. If decals are defaced or missing, replace them. Free replacement decals are available from **Maxon Parts Department**.
- Consider the safety and location of bystanders and location of nearby objects when operating the Liftgate. Stand to one side of the platform while operating the Liftgate
- Do not allow untrained persons to operate the Liftgate.
- Do not stand under, or allow obstructions under the platform when lowering the Liftgate. **Be sure your feet are clear of the Liftgate.**
- **Keep fingers, hands, arms, legs, and feet clear of moving Liftgate parts (and platform edges) when operating the Liftgate.**
- **Correctly stow platform when not in use. Extended platforms could create a hazard for people and vehicles passing by.**
- **Disconnect Liftgate power cable from battery** before repairing or servicing Liftgate.
- Wear appropriate safety equipment such as protective eyeglasses, faceshield and clothing while performing maintenance on the Liftgate and handling the battery. Debris from drilling and contact with battery acid may injure unprotected eyes and skin.
- Be careful working by an automotive type battery. Make sure the work area is well ventilated and there are no flames or sparks near the battery. Never lay objects on the battery that can short the terminals together. If battery acid gets in your eyes, immediately seek first aid. If acid gets on your skin, immediately wash it off with soap and water.
- If an emergency situation arises (vehicle or Liftgate) while operating the Liftgate, release the control Toggle Switch and the Liftgate will stop.
- A correctly installed Liftgate operates smoothly and reasonably quiet. The only noticeable noise during operation comes from the pump unit while the platform is raised. Listen for scraping, grating and binding noises and correct the problem before continuing to operate Liftgate.
- If it is necessary to stand on the platform while maintaining the Liftgate, keep your feet and any objects clear of the inboard edge of the platform. Your feet or objects on the platform could be trapped between the platform and the Liftgate extension plate.
- Never perform unauthorized modifications on the Liftgate. Modifications may result in early failure of the Liftgate and may create hazards for Liftgate operators and maintainers.
- Use only **Maxon Authorized Parts** for replacement parts. Provide Liftgate model and serial number information with your parts order. Order replacement parts from:

MAXON LIFT CORP. Customer Service
11921 Slauson Ave., Santa Fe Springs, CA 90670
Phone: (800) 227-4116

- To order parts by e-mail, submit orders to partssales@maxonlift.com.

MAXON[®]

11921 Slauson Ave. Santa Fe Springs, CA. 90670 (800) 227-4116 FAX (888) 771-7713

LIFTGATE TERMINOLOGY

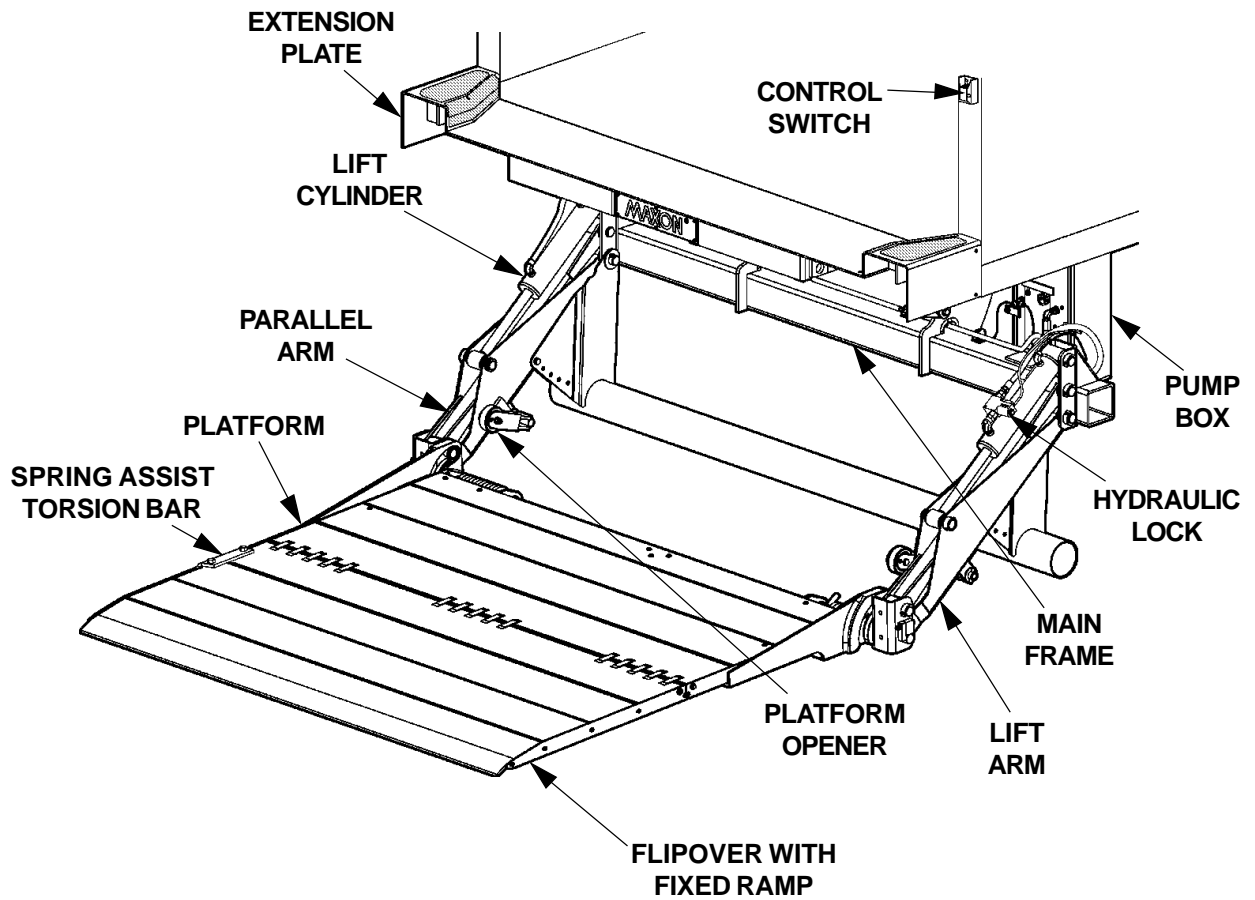

PERIODIC MAINTENANCE

PERIODIC MAINTENANCE CHECKLIST

⚠ WARNING

Never operate the Liftgate with parts loose or missing.

NOTE: Make sure Vehicle is parked on level ground while performing the maintenance checks.

Annually or 5000 Cycles (whichever occurs first)

Visually check the entire Liftgate for excessively worn parts and broken welds, especially Hinge Pins. See **PARTS BREAKDOWN** section for replacement parts.

Check the Platform and Flipover as follows. With Platform open at Bed Height (Vehicle Body), check the outboard edge of Flipover. The outboard edge must be just above level line as shown in **FIG. 8-1**. If outboard edge of Flipover is below the level line, check pins and bearings at the pivot points on both sides of the Liftgate (see **FIG. 8-2**). Also, for Aluminum Flipovers equipped with Aluminum Retention Ramp and for Steel Flipovers, ensure latch is in place, undamaged, and working correctly. See **PARTS BREAKDOWN** section for replacement parts.

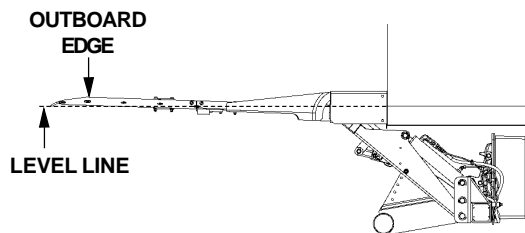

**PLATFORM EDGE ABOVE
BED LEVEL
FIG. 8-1**

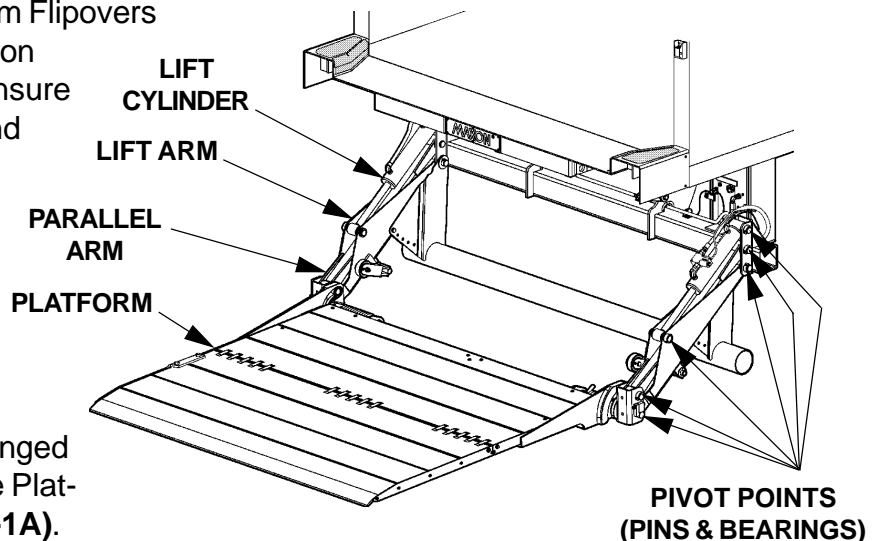

**PIVOT POINTS TO CHECK
FIG. 8-2**

To prevent unnecessary wear on Parallel Arms, check for worn flanged bearings as follows. Position the Platform 1"-2" above ground (**FIG. 9-1A**). Push against the Shackle (**FIG. 9-1B, item 1**) and measure clearance (**FIG. 9-1B, item 1**). Then push against other side of Shackle (**FIG. 9-1B, item 2**) and measure clearance (**FIG. 9-1B, item 2**). Repeat for LH side Shackle. If clearance is less than 0.060", replace flanged bearing. See **PARTS BREAKDOWN** section for replacement parts.

Also, do the **Semi-annual or 2500 Cycles** and **Quarterly or 1250 Cycles** checks.

MAXON

11921 Slauson Ave. Santa Fe Springs, CA. 90670 (800) 227-4116 FAX (888) 771-7713

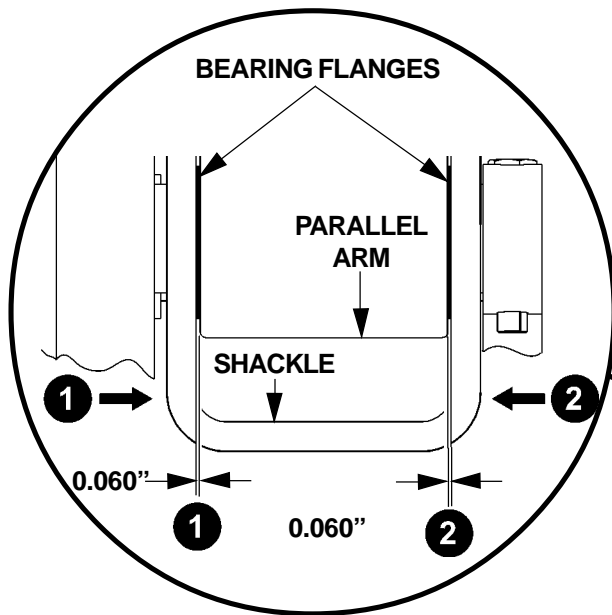

CHECKING SHACKLE CLEARANCES (RH SIDE SHOWN)
FIG. 9-1B

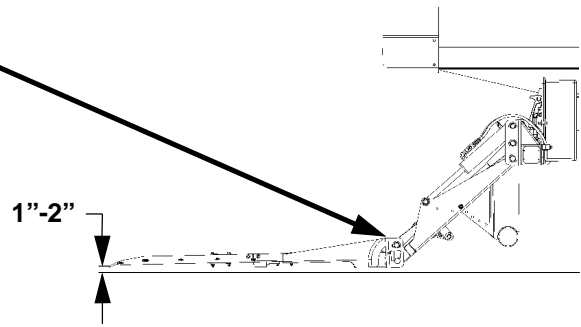

PLATFORM AT GROUND LEVEL
FIG. 9-1A

Semi-annually or 2500 Cycles (whichever occurs first)

Visually check the Platform Hinge Pins for excessive wear and broken welds. See **PARTS BREAKDOWN** section for replacement parts. Also, do the **Quarterly or 1250 Cycles** maintenance checks.

Quarterly or 1250 Cycles (whichever occurs first)

Check the Hydraulic Fluid level in the Pump Reservoir. Refer to the **CHECKING HYDRAULIC FLUID** procedure in the **PERIODIC MAINTENANCE** section.

If Hydraulic Fluid appears contaminated, refer to the **CHANGING HYDRAULIC FLUID** procedure in the **PERIODIC MAINTENANCE** section.

Keep track of the grade of Hydraulic Fluid in the Pump Reservoir and never mix two different grades of fluid.

Check all Hoses and Fittings for chaffing and fluid leaks. Make sure Hydraulic Lock is in place and undamaged. Replace if necessary.

Check electrical wiring for chaffing and make sure wiring connections are tight and free of corrosion.

Check that all **WARNING and instruction decals, nonskid stickers, and safety striping** are in place. Also make sure decals are readable and decals, nonskid, and safety striping are clean and undamaged.

Check that all nuts and bolts are tightened correctly, and that none are damaged or missing. Refer to the **PARTS** section and **RECOMMENDED BOLT TORQUES** in this manual.

Check that all roll pins are in place and protrude evenly from both sides of Hinge Pin collar. Replace roll pins if necessary.

Check for rust and oily surfaces on Liftgate. If there is rust or oil on Liftgate, clean it off. Touch up the paint where bare metal is showing.

PERIODIC MAINTENANCE CHECKING HYDRAULIC FLUID

CAUTION

Keep dirt, water and other contaminants from entering the hydraulic system. Before opening the hydraulic fluid reservoir filler cap, drain plug and hydraulic lines, clean up contaminants that can get in the openings. Also, protect the openings from accidental contamination.

NOTE: Use correct grade of hydraulic fluid for your location.

- | | |
|------------------------------|-------------------------------------|
| +70 to +140 Degrees F | - Grade ISO 32 |
| +40 to +105 Degrees F | - Grade ISO 15 |
| Below + 70 Degrees F | - Grade ISO 10 or MIL-H-5606 |

See TABLES 11-1, 11-2 & 11-3 on the next page for recommended brands.

1. Unbolt & remove Pump Cover (FIG. 8-2).

NOTE: If the Hydraulic Fluid in the Reservoir is contaminated, do the **CHANGING HYDRAULIC FLUID** procedure in this section.

2. Check the Hydraulic Fluid level in Reservoir. With Liftgate stowed or Platform at Vehicle bed height, Level should be 3" (FIG. 10-1). If needed, add fluid to the Reservoir as follows.

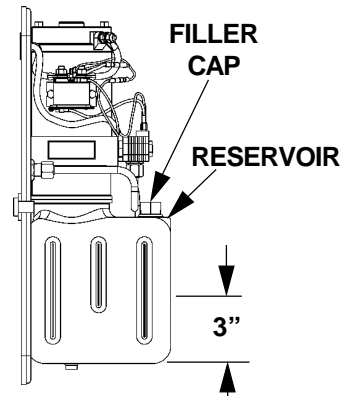

**POWER UNIT FLUID LEVEL
FIG. 10-1**

3. Pull out (no threads) Filler Cap (FIG. 10-1). Fill the Reservoir with Hydraulic Fluid to level shown in FIG. 10-1. Reinstall Filler Cap (FIG. 10-1)

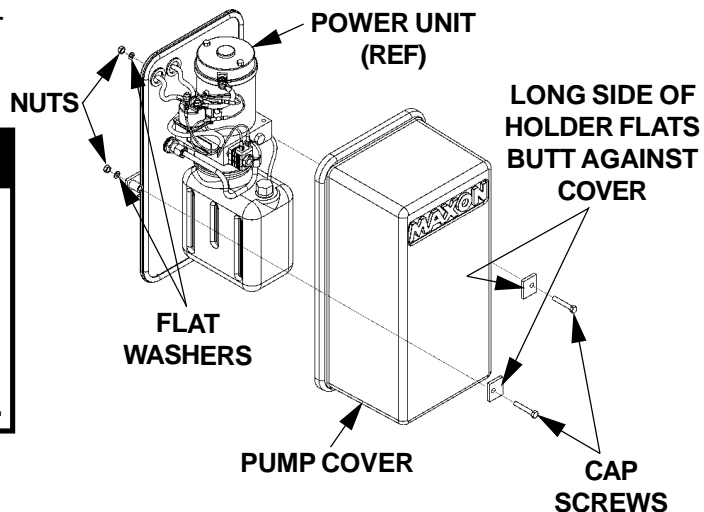

**UNBOLTING / BOLTING PUMP COVER
FIG. 10-2**

CAUTION

Pump Cover must be correctly secured to prevent it from becoming a hazard. To secure Pump Cover, the long side of the Holder Flats must butt against Pump Cover as shown in the illustration.

4. Bolt on the Pump Cover as shown in FIG. 10-2. Torque the 5/16"-18 cover bolts 20 to 29 LBS.-FT.

ISO 32 HYDRAULIC OIL	
RECOMMENDED BRANDS	PART NUMBER
AMSOIL	AWH-05
CHEVRON	HIPERSYN 32
KENDALL	GOLDEN MV
SHELL	TELLUS T-32
EXXON	UNIVIS N-32
MOBIL	DTE-13M, DTE-24, HYDRAULIC OIL-13

TABLE 11-1

ISO 15 HYDRAULIC OIL	
RECOMMENDED BRANDS	PART NUMBER
AMSOIL	AWF-05
CHEVRON	FLUID A, AW-MV-15
KENDALL	GLACIAL BLU
SHELL	TELLUS T-15
EXXON	UNIVIS HVI-13
MOBIL	DTE-11M

TABLE 11-2

ISO-10 OR MIL-H-5606 HYDRAULIC FLUID	
RECOMMENDED BRANDS	PART NUMBER
AMSOIL	N/A
CHEVRON	FLUID A, FLUID G
KENDALL	GLACIAL BLU
SHELL	AEROSHELL FLUID-41
EXXON	UNIVIS HVI-13
MOBIL	AERO HFA

TABLE 11-3

PERIODIC MAINTENANCE CHANGING HYDRAULIC FLUID

CAUTION

Keep dirt, water and other contaminants from entering the hydraulic system. Before opening the hydraulic fluid reservoir filler cap, drain plug and hydraulic lines, clean up contaminants that can get in the openings. Also, protect the openings from accidental contamination.

NOTE: Use correct grade of hydraulic fluid for your location.

+70 to +140 Degrees F - Grade ISO 32
 +40 to +105 Degrees F - Grade ISO 15
 Below + 70 Degrees F - Grade ISO 10 or MIL-H-5606

See TABLES 11-1, 11-2 & 11-3 on previous page for recommended brands.

GRAVITY DOWN LIFTGATES

1. Remove the Pump Cover (FIG. 12-2). Place empty 5 Gallon Bucket under Drain Plug (FIG. 12-1).
2. Lower Platform to ground. Pull out (no threads) Drain Plug (FIG. 12-1). Drain hydraulic fluid from system. Reinstall Drain Plug.
3. Pull out (no threads) Filler Cap (FIG. 12-1) and refill reservoir with Hydraulic Fluid to level shown in FIG. 12-1. Reinstall Filler Cap (FIG. 12-1).

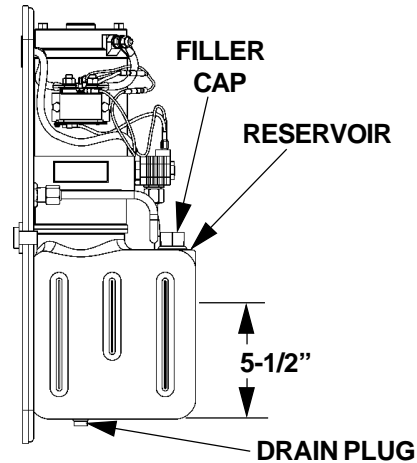

GRAVITY DOWN PUMP & MOTOR
FIG. 12-1

CAUTION

Pump Cover must be correctly secured to prevent it from becoming a hazard. To secure Pump Cover, the long side of the Holder Flats must butt against Pump Cover as shown in the illustration.

4. Bolt on the Pump Cover as shown in FIG. 12-2. Torque the 5/16"-18 cover bolts 20 to 29 LBS.-FT.

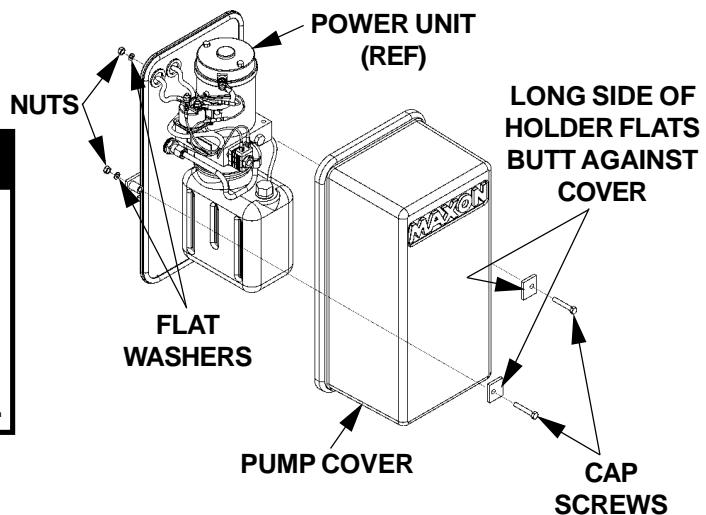

UNBOLTING / BOLTING PUMP COVER
FIG. 12-2

POWER DOWN LIFTGATES

1. Remove the Pump Cover (**FIG. 12-2**). Place empty 5 Gallon Bucket under Drain Plug (**FIG. 12-1**).
2. Open and raise Platform to vehicle bed height. Pull out (no threads) Drain Plug (**FIG. 12-1**). Drain hydraulic fluid.
3. Disconnect the Motor Power Cable (**FIG. 13-1**) from bottom Starter Solenoid. Lower the Platform while draining the remaining hydraulic fluid from system. Reinstall Drain Plug. Reconnect the Motor Power Cable to bottom Starter Solenoid. Torque hex nut to **95 LBS.-IN.**
4. Pull out (no threads) Filler Cap (**FIG. 12-1**) and refill reservoir with Hydraulic Fluid to level shown in **FIG. 12-1**. Reinstall Filler Cap (**FIG. 12-1**).

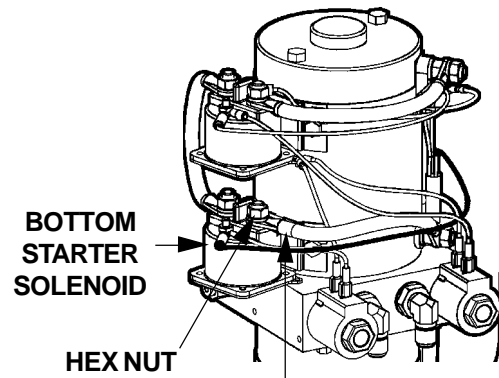

**MOTOR POWER
CABLE
POWER DOWN PUMP
FIG. 13-1**

CAUTION

Pump Cover must be correctly secured to prevent it from becoming a hazard. To secure Pump Cover, the long side of the Holder Flats must butt against Pump Cover as shown in the illustration.

5. Bolt on the Pump Cover as shown in **FIG. 12-2**. Torque the 5/16"-18 cover bolts **20 to 29 LBS.-FT.**

PERIODIC MAINTENANCE

REPLACING PLATFORM TORSION SPRING

NOTE: The following procedure shows how to replace Torsion Spring on RH side of Platform. Use this procedure for replacing Torsion Spring on the LH Side.

1. Fold Flipover onto Platform.
2. Fold Platform.
3. Raise Liftgate to a convenient work height to gain access and release tension on the Torsion Spring.

⚠ CAUTION

To prevent injury and equipment damage, make sure there is no tension on torsion spring before removing hinge pin.

4. Unbolt Hinge Pin from Shackle and Spring Bracket (**FIG. 14-1**). Remove bolts, washers, and lock nuts. Drive the Hinge Pin outboard toward the Shackle just enough to free the torsion spring (**FIG. 14-2**). Remove the Torsion Spring.
5. Install the Torsion Spring as shown in **FIG. 14-3**. Make sure the long leg of the spring is inserted in the Spring Bracket (**FIG. 14-3**). Make sure the short end of the spring is visible and resting against the Hinge Bracket (**FIG. 14-3**).
6. Drive the Hinge Pin into correct position through the Hinge Bracket as shown in **FIG. 14-3**. Line up the bolt hole in the Hinge Pin with the hole in the Shackle and Spring Bracket. Bolt the Hinge Pin to Hinge Bracket and Spring Bracket with bolts, washers, lock nuts (**FIG. 14-2**). Torque the 3/8"-16 Spring Pin bolt and 3/8"-16 Spring Bracket bolt **35 to 52 LBS.-FT.**

7. Operate the Liftgate according to instructions in **Operation Manual** to make sure it operates correctly.

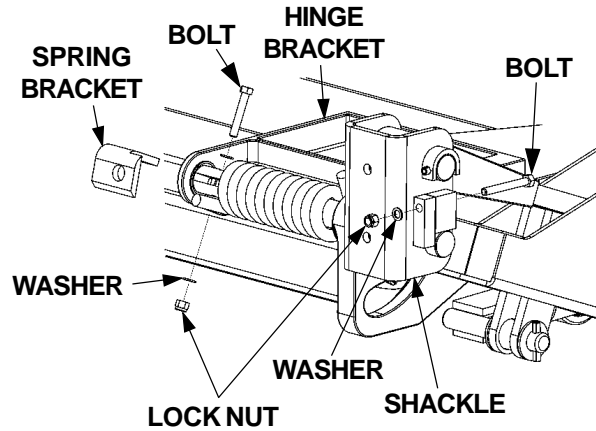

FIG. 14-1

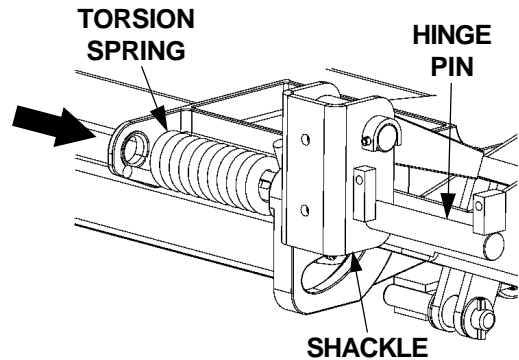

FIG. 14-2

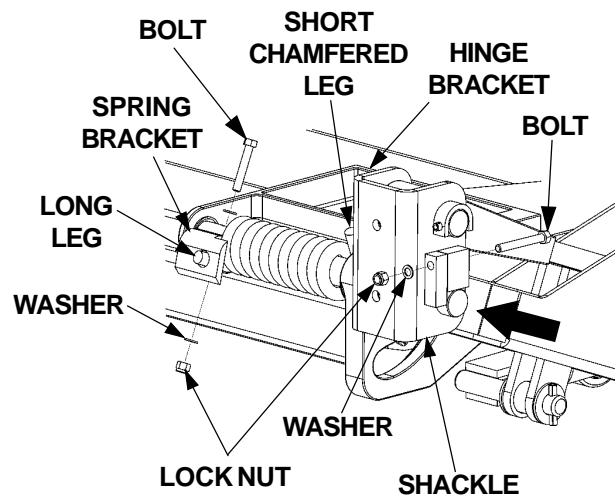

FIG. 14-3

PARTS BREAKDOWN

GPT MAIN ASSEMBLY (ALUMINUM PLATFORM)

MAXON®

11921 Slauson Ave. Santa Fe Springs, CA. 90670 (800) 227-4116 FAX (888) 771-7713

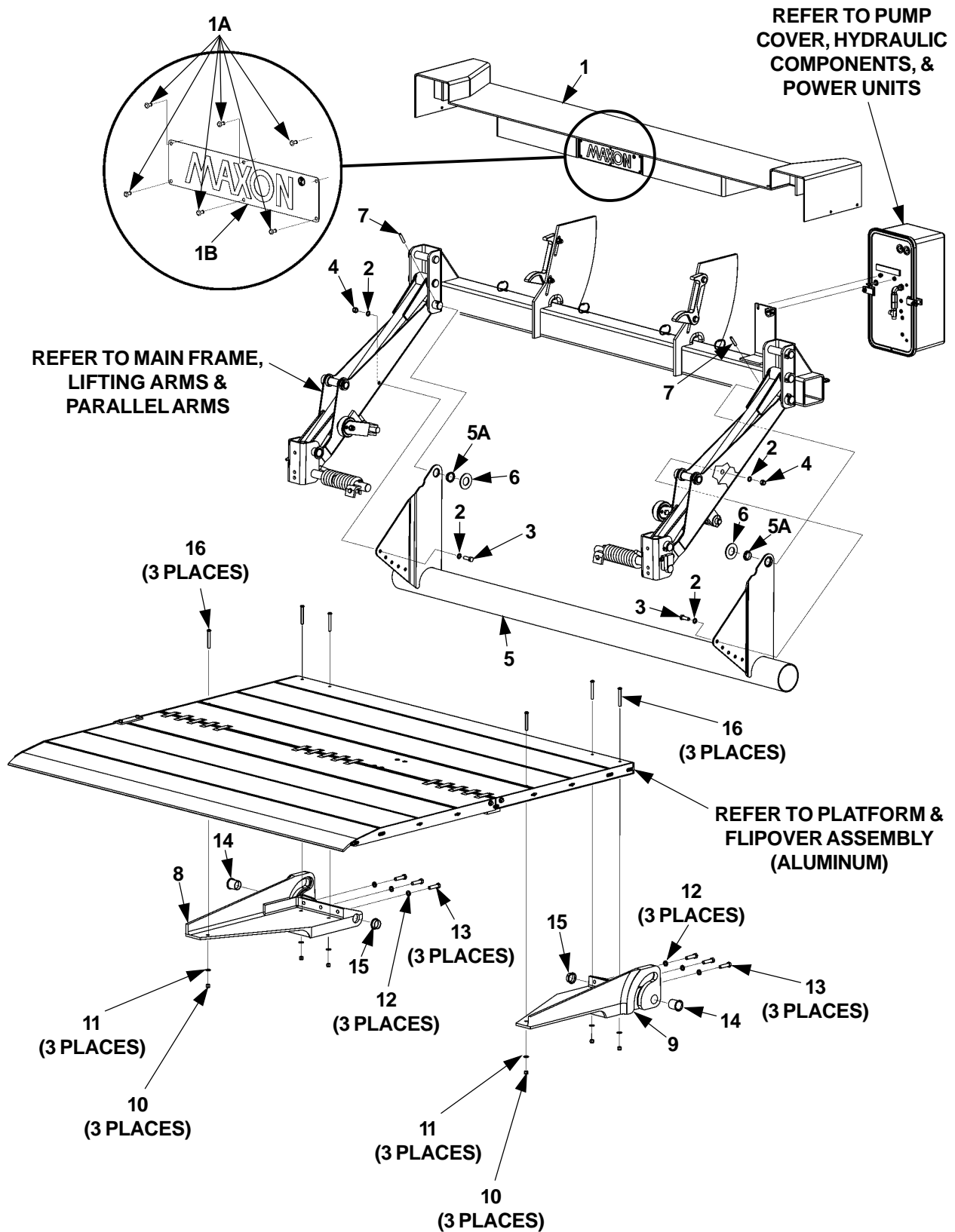

ITEM	QTY.	PART NO.	DESCRIPTION
1	1	281090-01	EXTENSION PLATE ASSEMBLY, 96" LG.
		281090-02	EXTENSION PLATE ASSEMBLY, 102" LG.
1A	6	207644	RIVET
1B	1	050175	MAXON PLATE
2	4	902000-14	FLAT WASHER, 1/2"
3	2	900035-3	CAP SCREW, 1/2"-13 X 1-1/2" LG.
4	2	901010	LOCK NUT, 1/2"-13
5	1	280998-01	UNDERRIDE, 96"
		280998-02	UNDERRIDE, 102"
5A	2	908008-01	BEARING
6	2	902013-21	FLAT WASHER, 1-3/8"
7	2	221416	ROLL PIN
8	1	281207-02	SUPPORT, LH
9	1	281207-01	SUPPORT, RH
10	6	901002	LOCK NUT, 3/8"-16
11	6	902013-11	FLAT WASHER, 3/8"
12	6	902011-6	LOCK WASHER, 1/2"
13	6	900035-5	CAP SCREW, 1/2"-13 X 2" LG.
14	2	908026-01	BEARING, 1-3/4" LG.
15	2	908008-02	BEARING, 5/8" LG.
16	6	900064-07	BUTTONHEAD SCREW, 3/8"-16 X 3" LG.

GPT MAIN ASSEMBLY (STEEL PLATFORM)

MAXON® 11921 Slauson Ave. Santa Fe Springs, CA. 90670 (800) 227-4116 FAX (888) 771-7713

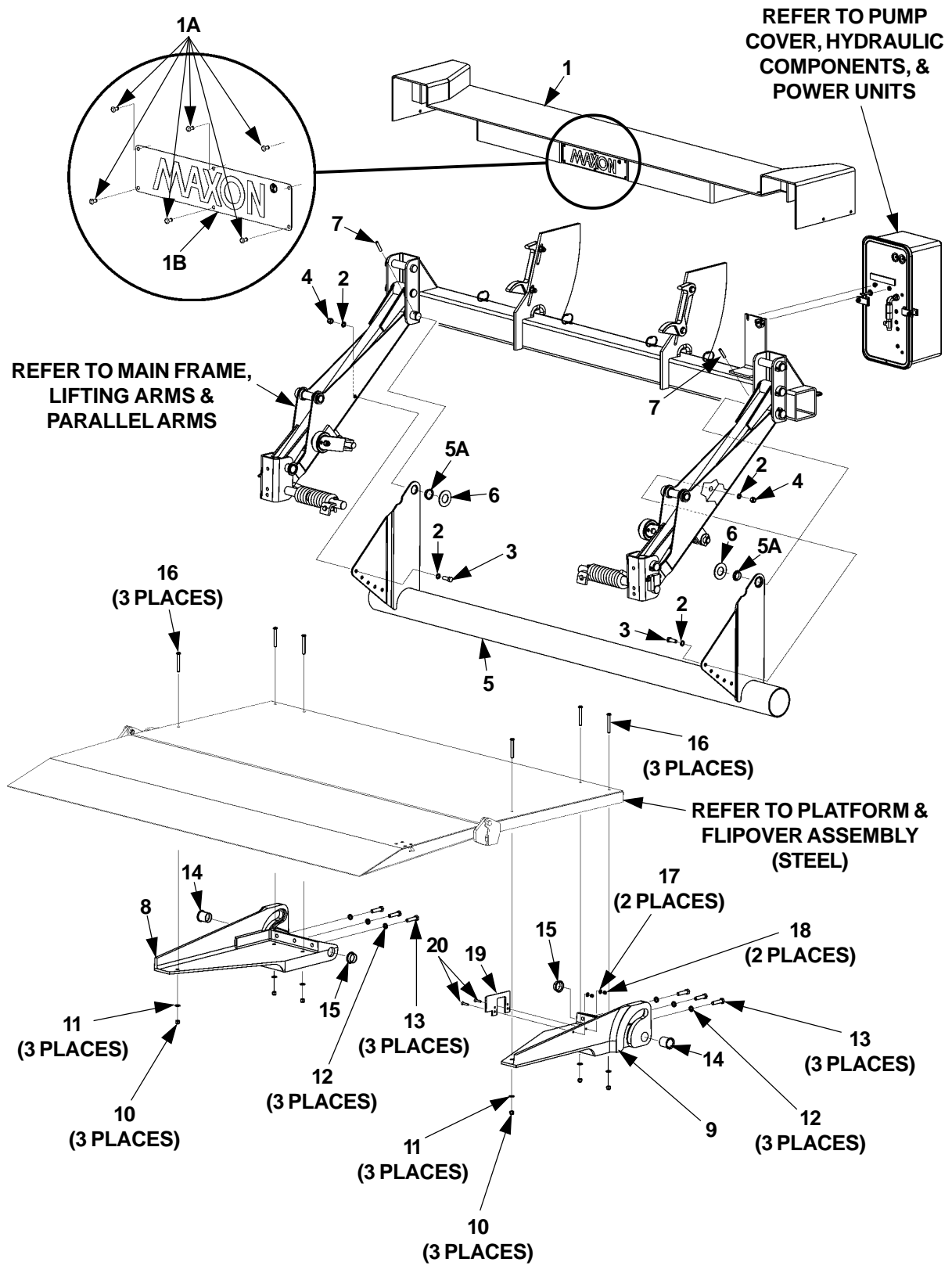

ITEM	QTY.	PART NO.	DESCRIPTION
1	1	281090-01	EXTENSION PLATE ASSEMBLY, 96" LG.
		281090-02	EXTENSION PLATE ASSEMBLY, 102" LG.
1A	6	207644	RIVET
1B	1	050175	MAXON PLATE
2	4	902000-14	FLAT WASHER, 1/2"
3	2	900035-3	CAP SCREW, 1/2"-13 X 1-1/2" LG.
4	2	901010	LOCK NUT, 1/2"-13
5	1	280998-01	UNDERRIDE, 96"
		280998-02	UNDERRIDE, 102"
5A	2	908008-01	BEARING
6	2	902013-21	FLAT WASHER, 1-3/8"
7	2	221416	ROLL PIN
8	1	281207-02	SUPPORT, LH
9	1	281207-01	SUPPORT, RH
10	6	901002	LOCK NUT, 3/8"-16
11	6	902013-11	FLAT WASHER, 3/8"
12	6	902011-6	LOCK WASHER, 1/2"
13	6	900035-11	CAP SCREW, 1/2"-13 X 4" LG.
14	2	908026-01	BEARING, 1-3/4" LG.
15	2	908008-02	BEARING, 5/8" LG.
16	6	900064-07	BUTTONHEAD SCREW, 3/8"-16 X 3" LG.
17	2	902013-09	FLAT WASHER, 1/4"
18	2	901000	NYLON NUT, 1/4"-20
19	1	281154-01	LATCH BRACKET
20	2	900044-7	SOCKET SCREW, 1/4"-20 X 1-1/4" LG.

MAIN FRAME, LIFTING ARMS, & PARALLEL ARMS GPTLR-25 & GPTLR-33

MAXON®

11921 Slauson Ave. Santa Fe Springs, CA. 90670 (800) 227-4116 FAX (888) 771-7713

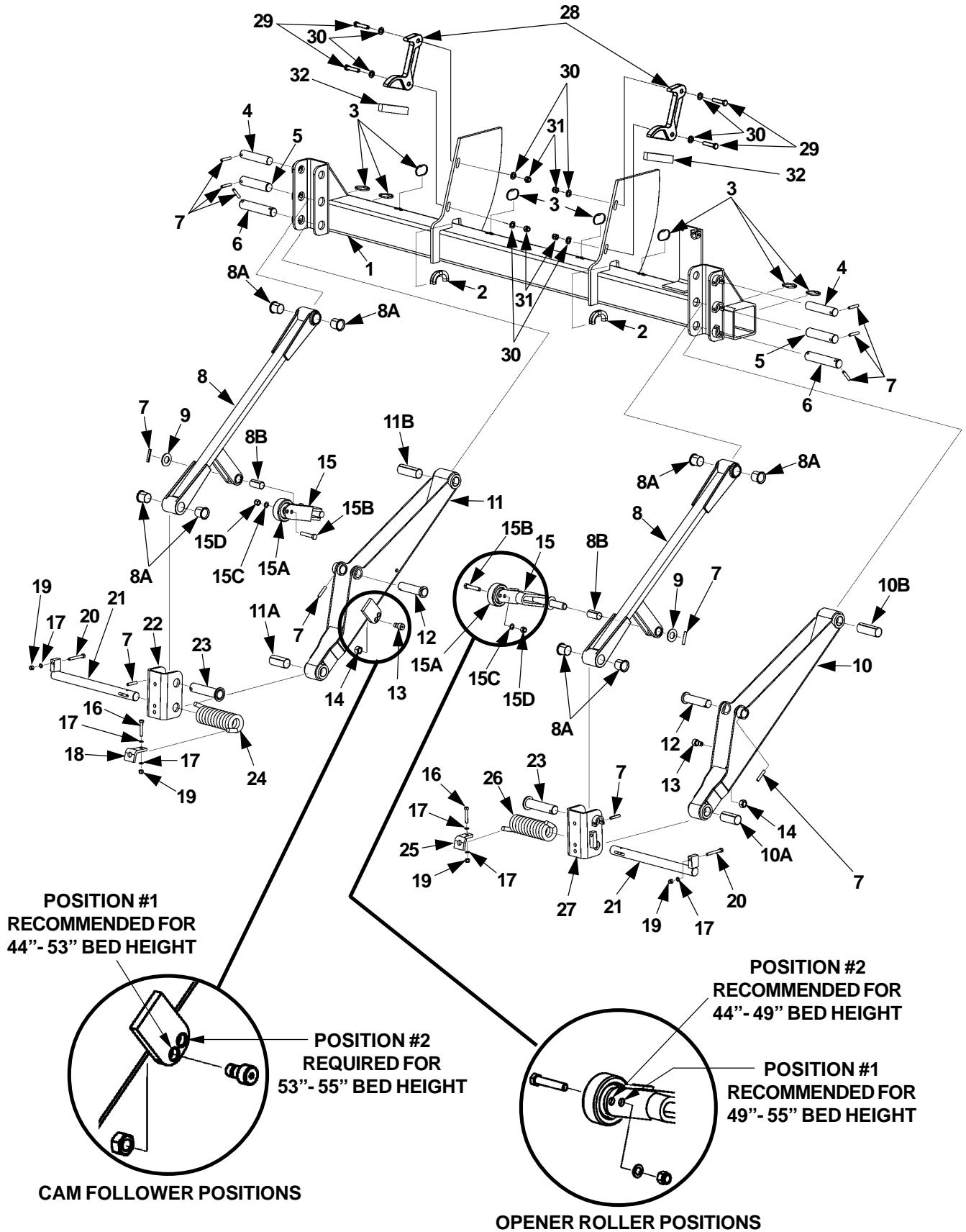

ITEM	QTY.	PART NO.	DESCRIPTION
1	1	280910-01	MAINFRAME, 96" WIDE
		280910-02	MAINFRAME, 102" WIDE
2	2	040103-5	SPLIT LOOM
3	8	205780	PLASTIC TIES
4	2	280969-02	PIN, 1-1/4" DIA X 5-13/16" LG.
5	2	280968-01	PIN, 1-3/8" DIA X 5-7/8" LG.
6	2	281005-01	PIN, 7" LG.
7	12	221416	ROLL PIN
8	2	280912-01	PARALLEL ARMS
8A	8	908037	BEARING
8B	2	908024-01	BEARING
9	2	902013-21	FLAT WASHER, 1-3/8"
10	1	280915-01	LIFT ARM, RH
10A	1	908023-01	BEARING
10B	1	908023-02	BEARING
11	1	280915-02	LIFT ARM, LH
11A	1	908023-01	BEARING
11B	1	908023-02	BEARING
12	2	281127-01	PIN, CYLINDER
13	2	908012-01	CAM FOLLOWER
14	2	030334	LOCK NUT, 5/8"-18
15	2	280918-01	OPENER
15A	2	280082-01	ROLLER
15B	2	900035-8	CAP SCREW, 1/2"-13 X 2-3/4" LG.
15C	2	902000-14	FLAT WASHER, 1/2"
15D	2	901010	LOCK NUT, 1/2"-13
16	2	900014-9	CAP SCREW, 3/8"-16 X 2-1/4" LG.
17	6	902000-10	FLAT WASHER, 3/8"
18	1	281000-02	BRACKET, LH
19	4	901002	LOCK NUT, 3/8"-16
20	2	900014-11	CAP SCREW, 3/8"-16 X 3" LG.
21	2	281004	PIN, SPRING
22	1	280971-02	SHACKLE, LH
23	2	280976-01	PIN, 5-5/8" LG.
24	1	280950-02	TORSION SPRING, LH (ALUMINUM PLATFORM)
		281319-02	TORSION SPRING, LH (STEEL PLATFORM)
25	1	281000-01	BRACKET, RH
26	1	280950-01	TORSION SPRING, RH (ALUMINUM PLATFORM)
		281319-01	TORSION SPRING, RH (STEEL PLATFORM)
27	1	280971-01	SHACKLE, RH
28	2	281102-01	SADDLE
29	4	900035-7	CAP SCREW 1/2"-13 X 2-1/2" LG.
30	8	902000-16	FLAT WASHER, 9/16"
31	4	901010	LOCK NUT, 1/2"-13
32	2	090300-11	FLAT (SADDLE SUPPORT)

MAXON[®] 11921 Slauson Ave. Santa Fe Springs, CA. 90670 (800) 227-4116 FAX (888) 771-7713

PLATFORM & FLIPOVER ASSEMBLY (ALUMINUM)

MAXON®

11921 Slauson Ave. Santa Fe Springs, CA. 90670 (800) 227-4116 FAX (888) 771-7713

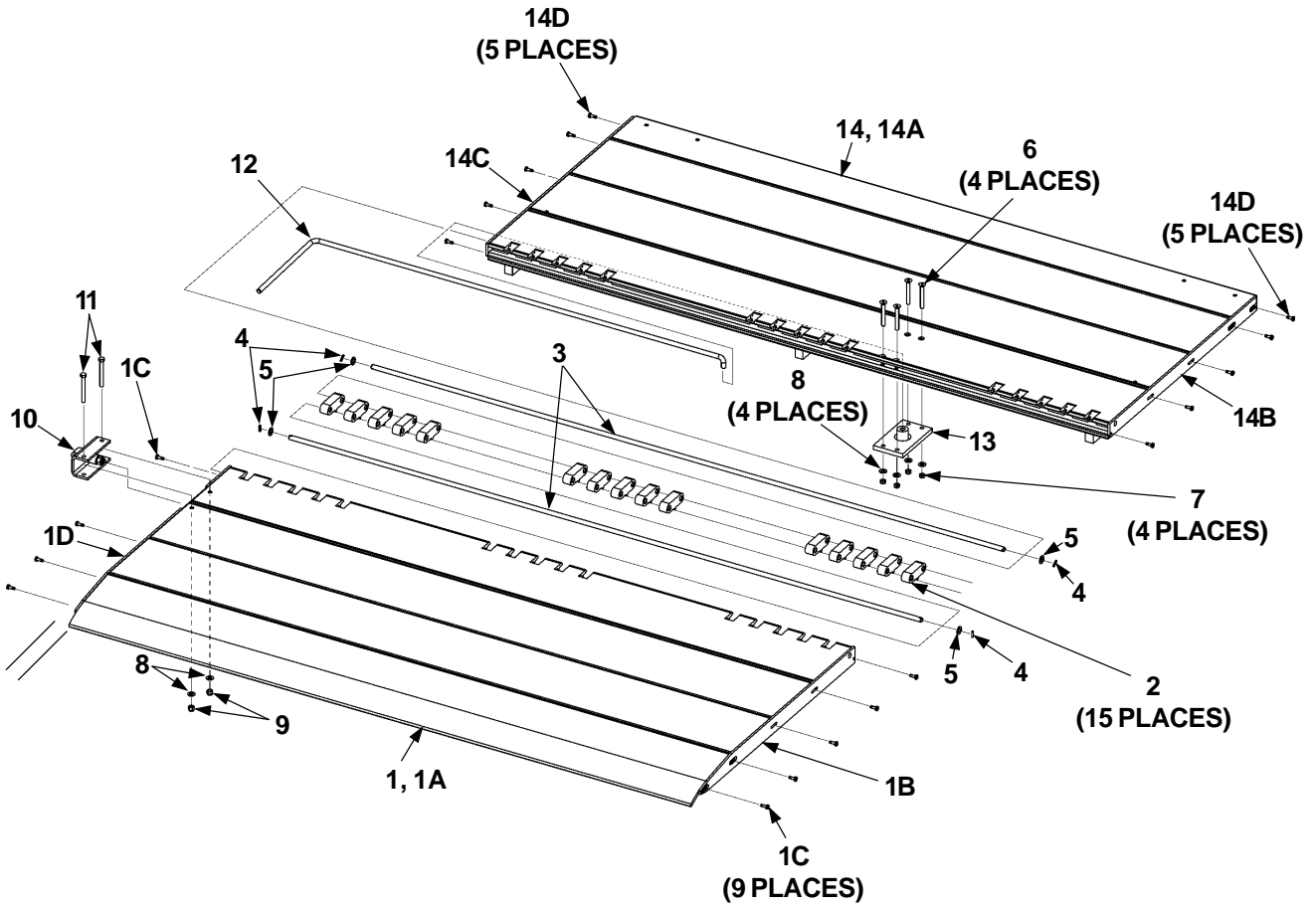

ITEM	QTY.	PART NO.	DESCRIPTION
1	1	281145-01	FLIPOVER ASSEMBLY, 79-1/2" LG.
		281145-02	FLIPOVER ASSEMBLY, 85-1/2" LG.
1A	1	281142-01	FLIPOVER WELDMENT, 79" LG.
		281142-02	FLIPOVER WELDMENT, 85" LG.
1B	1	280941-01	SIDE PLATE, FLIPOVER RH
1C	9	900705-01	SELF-TAPPING SCREW, 1/4"-20 X 1" LG.
1D	1	281146-01	SIDE PLATE, FLIPOVER LH
2	15	281010-01	HINGE ASSEMBLY
3	2	263456-12	HINGE, ROD, 80" LG.
		263456-13	HINGE, ROD, 86" LG.
4	4	905015-1	ROLL PIN
5	4	902000-14	FLAT WASHER, 1/2"
6	4	900040-11	SOCKETHEAD SCREW, 3/8"-16 X 3" LG.
7	4	901016-4	THIN HEX NUT, 3/8"-16
8	6	902013-11	FLAT WASHER, 3/8"
9	2	901002	NYLON NUT, 3/8"-16
10	1	281135-01	TORSION BAR BRACKET
11	2	900014-20	CAP SCREW, 3/8"-16 X 3-1/4" LG.
12	1	281141-01	TORSION BAR
13	1	281138-01	TORSION BAR HOLDER
14	1	281130-01	PLATFORM ASSEMBLY, 79-1/2" LG.
		281130-02	PLATFORM ASSEMBLY, 85-1/2" LG.
14A	1	281144-01	PLATFORM WELDMENT, 79" LG.
		281144-02	PLATFORM WELDMENT, 85" LG.
14B	1	280987-01	SIDE PLATE, RH, PLATFORM
14C	1	281143-01	SIDE PLATE, LH, PLATFORM
14D	10	900705-01	SELF-TAPPING SCREW, 1/4"-20 X 1" LG.

MAXON[®] 11921 Slauson Ave. Santa Fe Springs, CA. 90670 (800) 227-4116 FAX (888) 771-7713

PLATFORM WITH DUAL CART STOP & FLIPOVER ASSEMBLY (ALUMINUM)

MAXON®

11921 Slauson Ave. Santa Fe Springs, CA. 90670 (800) 227-4116 FAX (888) 771-7713

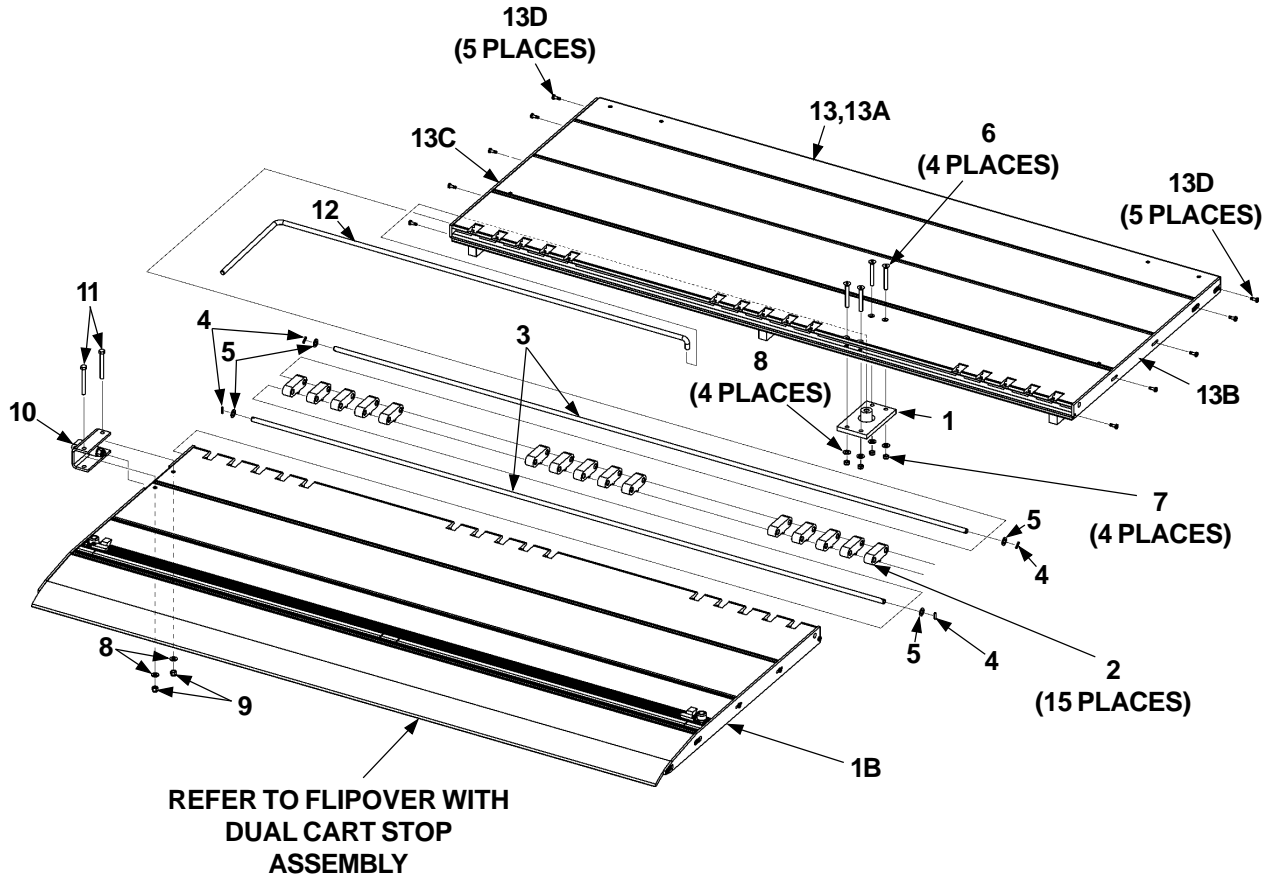

ITEM	QTY.	PART NO.	DESCRIPTION
1	1	281138-01	TORSION BAR HOLDER
2	15	281010-01	HINGE ASSEMBLY
3	2	263456-12	HINGE, ROD, 80" LG.
		263456-13	HINGE, ROD, 86" LG.
4	4	905015-1	ROLL PIN
5	4	902000-14	FLAT WASHER, 1/2"
6	4	900040-11	SOCKETHEAD SCREW, 3/8"-16 X 3" LG.
7	4	901016-4	THIN HEX NUT, 3/8"-16
8	6	902013-11	FLAT WASHER, 3/8"
9	2	901002	NYLON NUT, 3/8"-16
10	1	281135-01	TORSION BAR BRACKET
11	2	900014-20	CAP SCREW, 3/8"-16 X 3-1/4" LG.
12	1	281141-01	TORSION BAR
13	1	281130-01	PLATFORM ASSEMBLY, 79-1/2" LG.
		281130-02	PLATFORM ASSEMBLY, 85-1/2" LG.
13A	1	281144-01	PLATFORM WELDMENT, 79" LG.
		281144-02	PLATFORM WELDMENT, 85" LG.
13B	1	280987-01	SIDE PLATE, RH, PLATFORM
13C	1	281143-01	SIDE PLATE, LH, PLATFORM
13D	10	900705-01	SELF-TAPPING SCREW, 1/4"-20 X 1" LG.

FLIPOVER WITH DUAL CART STOPS (ALUMINUM)

MAXON®

11921 Slauson Ave. Santa Fe Springs, CA. 90670 (800) 227-4116 FAX (888) 771-7713

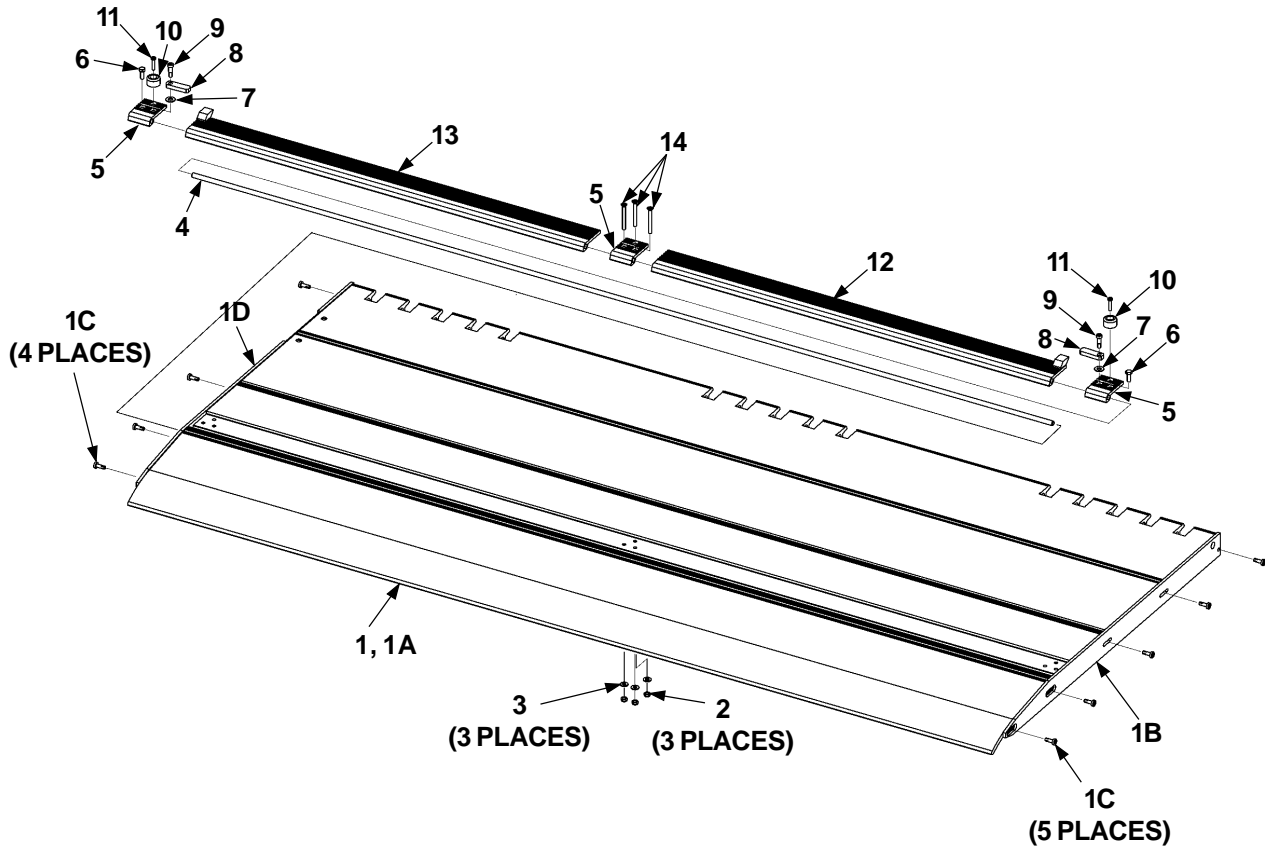

ITEM	QTY.	PART NO.	DESCRIPTION
1	1	267055-01	FLIPOVER ASSEMBLY, 79-1/2" LG.
		267055-02	FLIPOVER ASSEMBLY, 85-1/2" LG.
1A	1	267087-01	FLIPOVER WELDMENT, 79" LG.
		267087-02	FLIPOVER WELDMENT, 85" LG.
1B	1	280941-01	SIDE PLATE, FLIPOVER RH
1C	9	900705-01	SELF-TAPPING SCREW, 1/4"-20 X 1" LG.
1D	1	281146-01	SIDE PLATE, FLIPOVER LH
2	3	901016-2	THIN HEX NUT, 1/4"-20
3	3	902013-09	FLAT WASHER 1/4"
4	1	267094-01	PIN, 78-3/4" LG.
		267094-02	PIN, 84-3/4" LG.
5	3	267088-01	CART STOP LINK
6	2	900004-2	CAP SCREW, 1/4"-20 X 3/4" LG.
7	2	903409-02	FLAT WASHER, 11/32"
8	2	267204	CART STOP LOCKING BRACKET
9	2	900062-3	SHOULDER SCREW, 5/16" X 1/2" LG.
10	2	905314-03	BUMPER
11	2	900007-7	PAN HEAD SCREW, 10-24 X 1" LG.
12	1	267092-04	CART STOP WELDMENT RH, 36-3/8" LG.
		267092-06	CART STOP WELDMENT RH, 39-3/8" LG.
13	1	267092-05	CART STOP WELDMENT LH, 36-3/8" LG.
		267092-07	CART STOP WELDMENT LH, 39-3/8" LG.
14	3	900715-15	PAN HEAD SCREW, 1/4"-20 X 2-1/4" LG.

PLATFORM & FLIPOVER ASSEMBLY (STEEL)

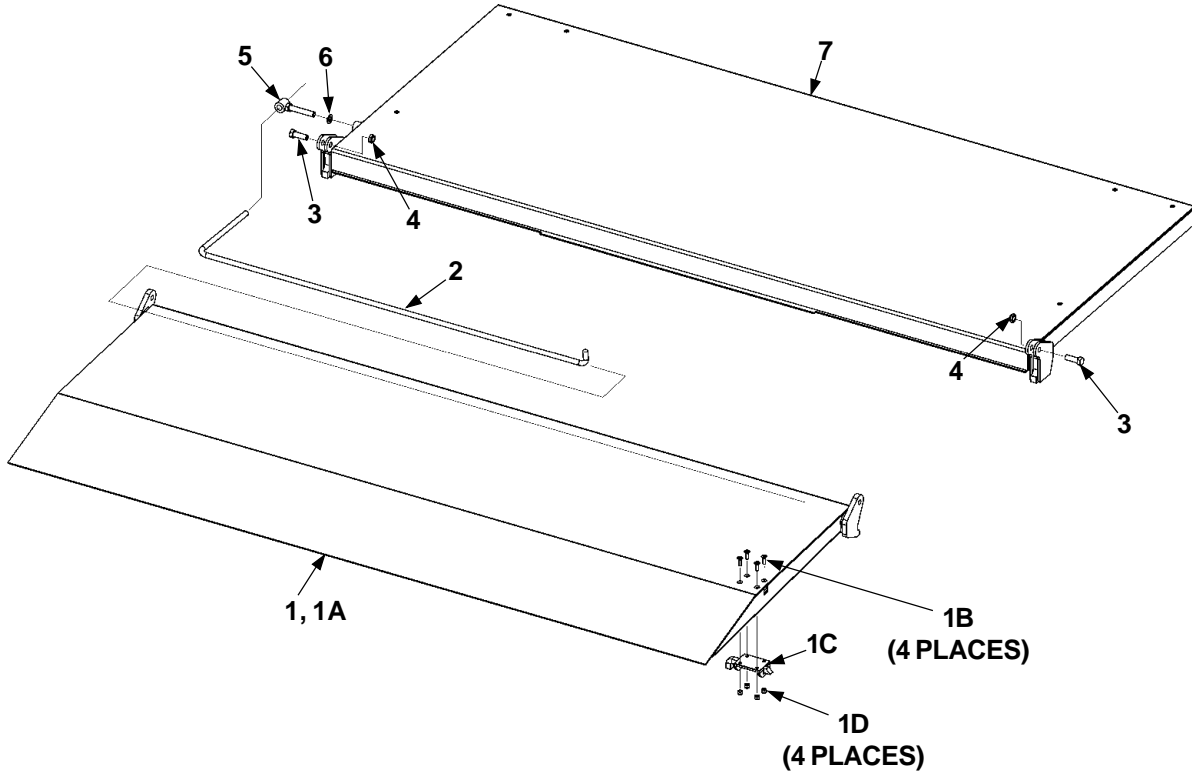

ITEM	QTY.	PART NO.	DESCRIPTION
1	1	267301-01	FLIPOVER ASSEMBLY, 79" LG.
		267301-02	FLIPOVER ASSEMBLY, 85" LG.
1A	1	267820-01	FLIPOVER WELDMENT, 79" LG.
		267820-02	FLIPOVER WELDMENT, 85" LG.
1B	4	900044-5	SOCKET SCREW, 1/4"-20 X 7/8" LG.
1C	1	267201-03	SLAM-LATCH
1D	4	901000	NUT, 1/4"-20
2	1	281302-01	TORSION BAR
3	2	900033-3	CAP SCREW, 1/2"-20 X 1-1/2" LG.
4	2	901016-1	THIN NUT, 1/2"-20
5	1	280749-01	ANCHOR BOLT
6	1	902000-14	FLAT WASHER, 1/2"
7	1	267825-01	PLATFORM WELDMENT, 79" LG.
		267825-02	PLATFORM WELDMENT, 85" LG.

MAXON®

11921 Slauson Ave. Santa Fe Springs, CA. 90670 (800) 227-4116 FAX (888) 771-7713

PUMP COVER & MOUNTING PLATE ASSEMBLY

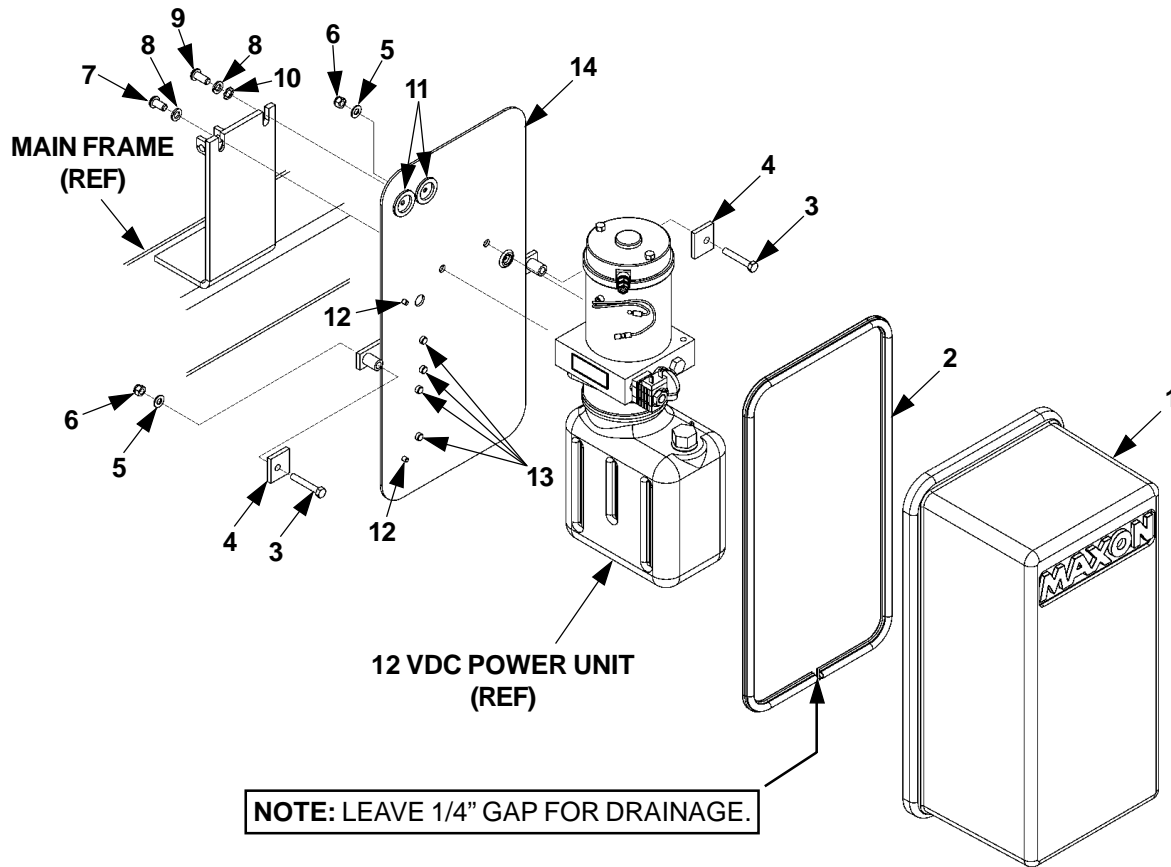

ITEM	QTY.	PART NO.	DESCRIPTION
1	1	281038-01	COVER ASSY
2	1	093203-10	GASKET, RUBBER CHANNEL, 60" LG.
3	2	90009-8	CAP SCREW, 5/16"-18 X 2" LG.
4	2	281062-02	HOLDER FLATS
5	2	902013-10	FLAT WASHER, 5/16"
6	2	901001	LOCK NUT, 5/16"-18
7	1	900064-03	BUTTONHEAD SCREW, 3/8"-16 X 3/4" LG.
8	2	902011-4	LOCK WASHER, 3/8"
9	1	900064-04	BUTTONHEAD SCREW, 3/8"-16 X 7/8" LG.
10	1	903400-02	LOCK WASHER, EXTERNAL TOOTH
11	2	266428-02	GROMMET, 1/4"HOLE
12	2	908022-01	PLUG, FLEXIBLE
13	4	908022-03	PLUG, FLEXIBLE
14	1	281065-01	PLATE, PUMP MOUNT

GRAVITY DOWN HYDRAULIC COMPONENTS

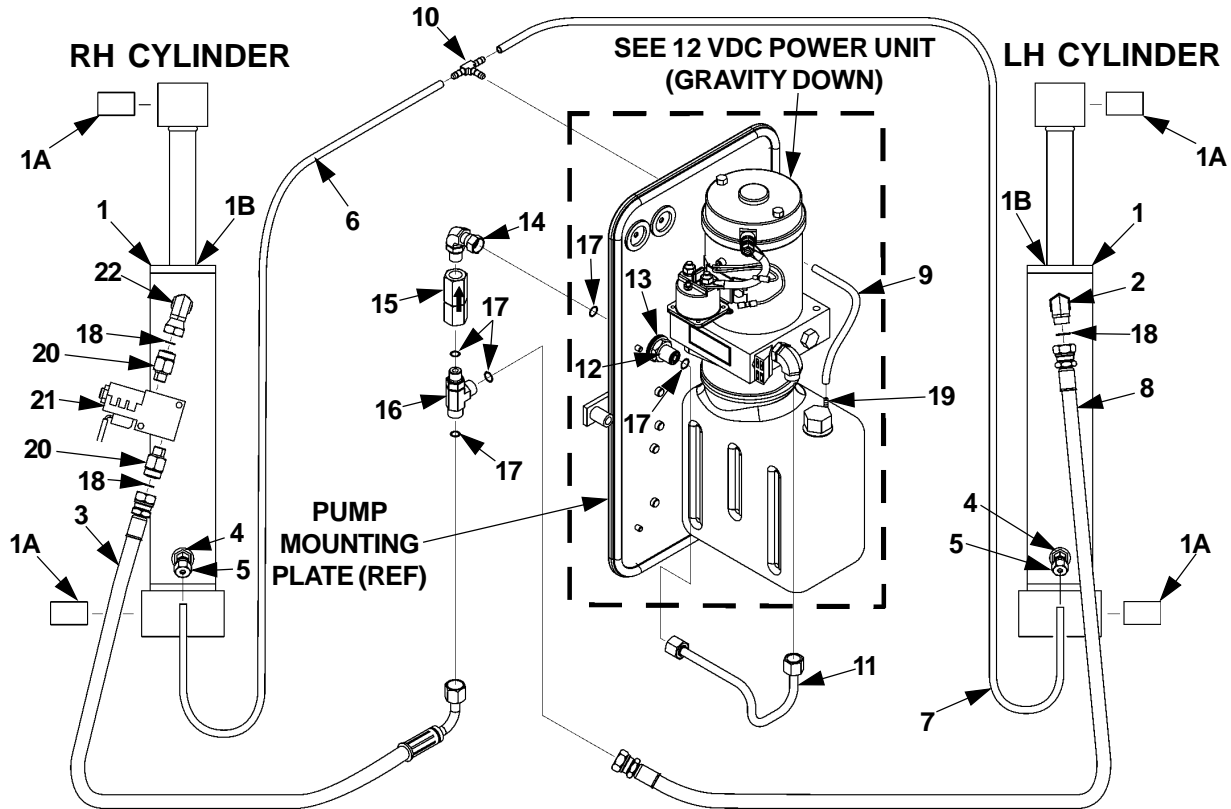

CAUTION

To prevent incorrect operation & damage to liftgate, make sure arrow on flow regulator valve points up as shown in illustration.

ITEM	QTY.	PART NO.	DESCRIPTION
1	2	280990-01	CYLINDER (GPT-25/33)
1A	2	908033	POLYLUBE BEARING
1B	2	280990SK-01	SEAL KIT (GPT-25/33 CYLINDER)
2	1	906704-01	ELBOW, 90° F/S, #8 M-M
3	1	281057-01	HOSE ASSY, 3/8" HP, 40" LG
4	2	228012	ADAPTER, STRAIGHT THREAD, 9/16"-18 M - 1/4" F
5	2	263811	ELBOW, MALE 45°
6	1	224370-21	HOSE, PLASTIC 38" LG
7	1	224370-18	HOSE, PLASTIC 95" LG
8	1	281057-02	HOSE ASSY, 3/8" HP, 112" LG
9	1	224370-20	HOSE, PLASTIC 9" LG
10	1	906749-01	UNION TEE
11	1	281067-01	F/S TUBE ASSY
12	1	906744-01	BULKHEAD UNION
13	3	902028-12	FLAT WASHER, 3/4"
14	1	906708-01	ELBOW, 90° F/S, #6 M-M
15	1	906709-03	FLOW REGULATOR VALVE, 3GPM
16	1	906745-01	BRANCH TEE
17	5	906712-02	O-RING #6 (3/8" FACE SEAL TUBE-END)
18	3	906712-03	O-RING #8 (1/2" FACE SEAL TUBE-END)
19	1	906728-01	DUAL BARBED FITTING
20	2	906762	CONNECTOR, M-M, 9/16"-18 X 3/4"
21	1	281308-01	HYDRAULIC LOCK
22	1	906763-01	CONNECTOR, M-M, 9/16"-18 X 13/16"-16

MAXON®

11921 Slauson Ave. Santa Fe Springs, CA. 90670 (800) 227-4116 FAX (888) 771-7713

12 VDC POWER UNIT (GRAVITY DOWN)

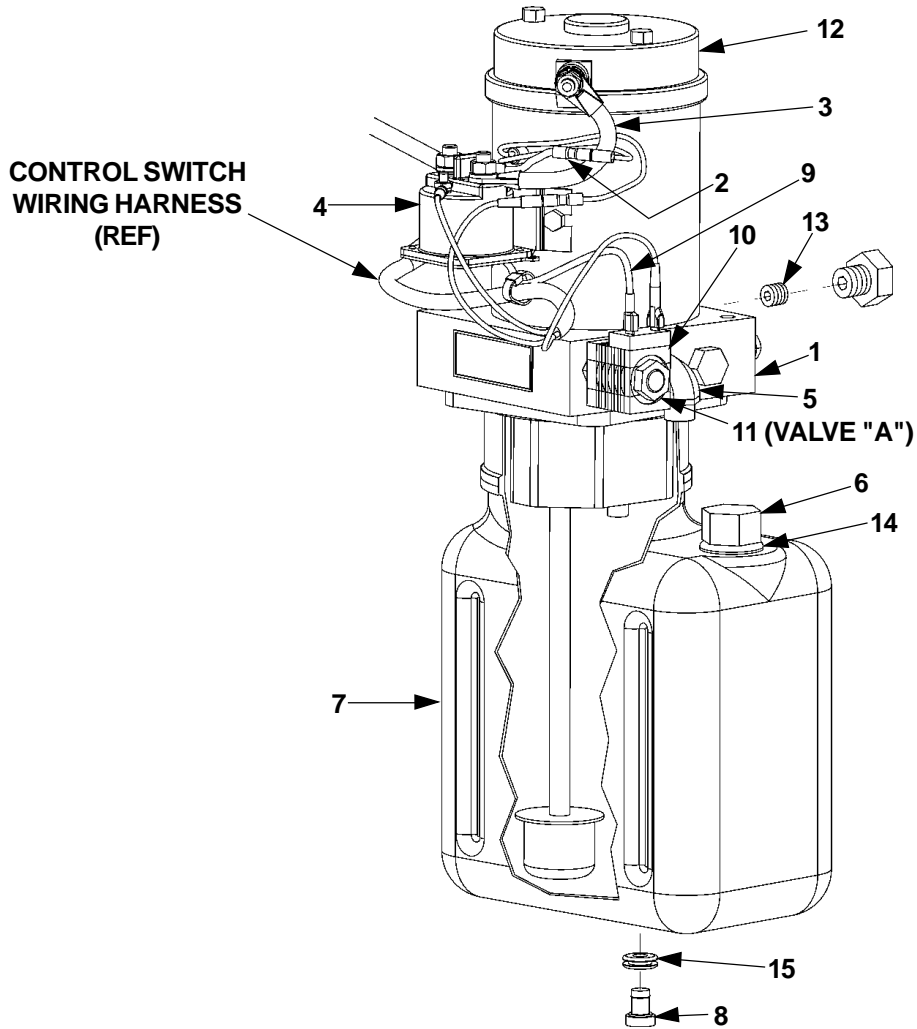

ITEM	QTY.	PART NO.	DESCRIPTION
	REF	281015-01	12 VDC POWER UNIT (GRAVITY DOWN)
1	1	290065	PORT PLATE & PUMP ASSEMBLY (GRAVITY DOWN)
2	1	280566-01	WIRE ASSEMBLY, 16 GA, GREEN
3	1	280404	CABLE ASSEMBLY
4	1	280394	MOTOR STARTER SOLENOID, 12 VOLTS DC
5	1	906707	90° ELBOW
6	1	280806-01	FILLER CAP
7	1	281013-01	RESERVOIR
8	1	908017-01	DRAIN PLUG
9	1	280416	WIRE ASSEMBLY
10	1	290064	12 VDC COIL
11	1	906719-01	VALVE (VALVE "A")
12	1	280374	MOTOR, 12 VOLTS DC
13	1	906737-01	RELIEF VALVE
14	1	908016-01	GROMMET, 19/32"
15	1	908018-01	GROMMET, 5/16"

POWER DOWN HYDRAULIC COMPONENTS

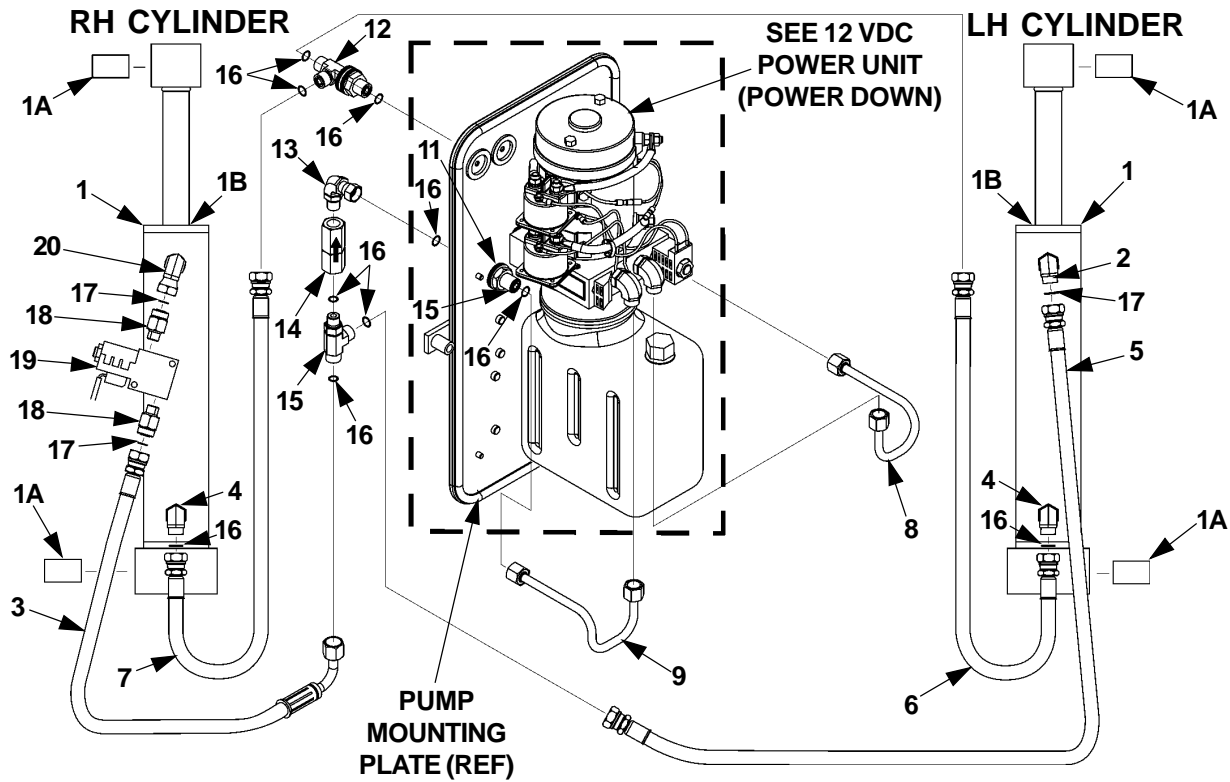

CAUTION

To prevent incorrect operation & damage to liftgate, make sure arrow on flow regulator valve points up as shown in illustration.

ITEM	QTY.	PART NO.	DESCRIPTION
1	2	280990-01	CYLINDER (GPT-25/33)
1A	2	908033	POLYLUBE BEARING
1B	2	280990SK-01	SEAL KIT (GPT-25/33 CYLINDER)
2	1	906704-01	ELBOW, 90° F/S, #8 M-M
3	1	281057-01	HOSE ASSY, 3/8" HP, 40" LG.
4	2	906707-01	ELBOW, 90° F/S, #6 M-M
5	1	281057-02	HOSE ASSY, 3/8" HP, 112" LG.
6	1	281058-02	HOSE ASSY, 3/8" HP, 95" LG.
7	1	281058-01	HOSE ASSY, 3/8" HP, 38" LG.
8	1	281055-01	F/S TUBE ASSY
9	1	281056-01	F/S TUBE ASSY
10	1	906744-01	BULKHEAD UNION
11	9	902028-12	FLAT WASHER, 3/4"
12	1	906748-01	BULKHEAD RUN TEE
13	1	906708-01	ELBOW, 90° F/S, #6 M-M
14	1	906709-03	FLOW REGULATOR VALVE, 3GPM
15	1	906745-01	BRANCH TEE
16	10	906712-02	O-RING, #6 (3/8" FACE SEAL TUBE-END)
17	3	906712-03	O-RING, #8 (1/2" FACE SEAL TUBE-END)
18	2	906762	CONNECTOR, M-M, 9/16"-18 X 3/4"
19	1	281308-01	HYDRAULIC LOCK
20	1	906763-01	CONNECTOR, M-M, 9/16"-18 X 13/16"-16

MAXON®

11921 Slauson Ave. Santa Fe Springs, CA. 90670 (800) 227-4116 FAX (888) 771-7713

12 VDC POWER UNIT (POWER DOWN)

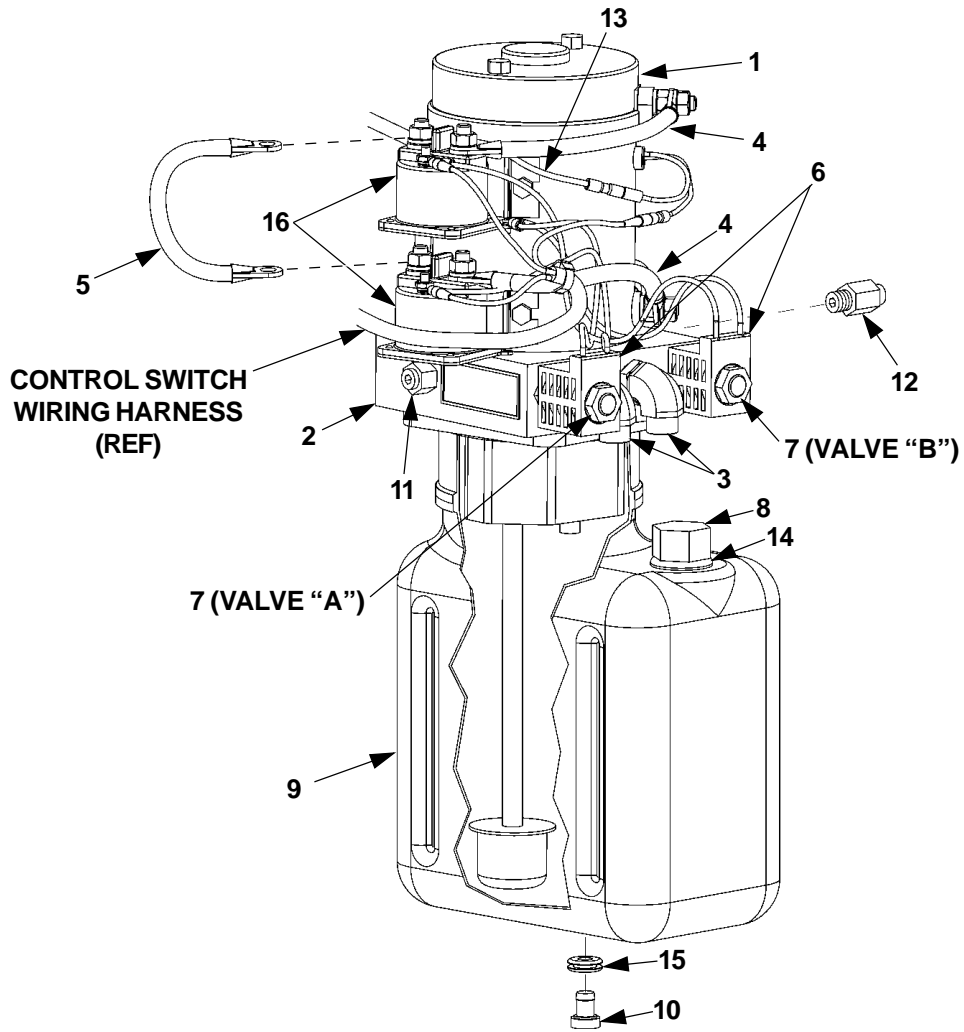

ITEM	QTY.	PART NO.	DESCRIPTION
	REF	281020-01	12 VDC POWER UNIT (POWER DOWN)
1	1	280381	MOTOR, 12 VOLTS DC
2	1	290066	PORT PLATE & PUMP ASSEMBLY (POWER DOWN)
3	2	906707-01	ELBOW, 90°
4	2	280404	CABLE ASSEMBLY
5	1	280543	CABLE ASSEMBLY
6	2	906720-01	10 VDC COIL
7	2	906719-01	VALVE
8	1	280806-01	FILLER CAP
9	1	281014-01	RESERVOIR
10	1	908017-01	DRAIN PLUG
11	1	906738-02	RELIEF VALVE, HP
12	1	906738-01	RELIEF VALVE, LP
13	1	280566-01	WIRE ASSEMBLY, 16 GA, GREEN
14	1	908016-01	GROMMET, 19/32"
15	1	908018-01	GROMMET, 5/16"
16	2	280394	MOTOR STARTER SOLENOID, 12 VOLTS DC

MAXON[®]

11921 Slauson Ave. Santa Fe Springs, CA. 90670 (800) 227-4116 FAX (888) 771-7713

DECALS

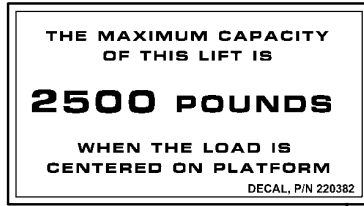

CAPACITY DECAL (GPT-25 ONLY)
P/N 220382

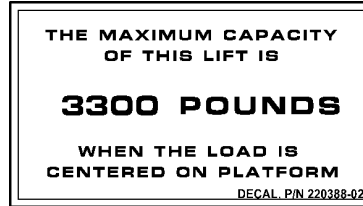

CAPACITY DECAL (GPT-33 ONLY)
P/N 220388-02

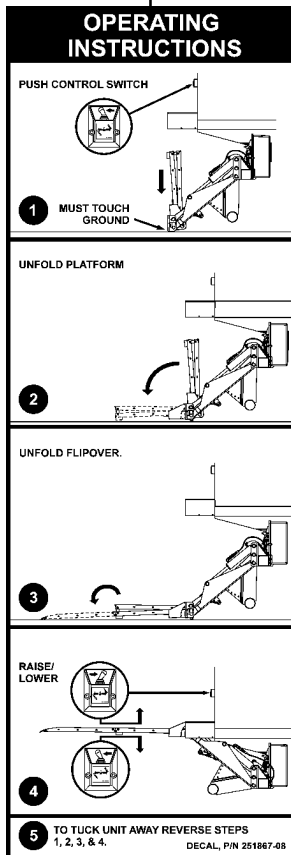
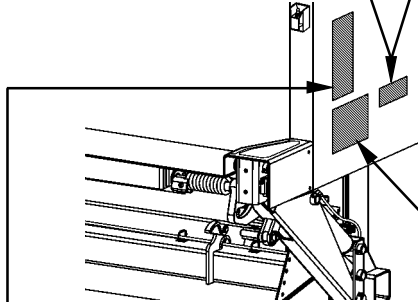

INSTRUCTION DECAL
P/N 251867-08.

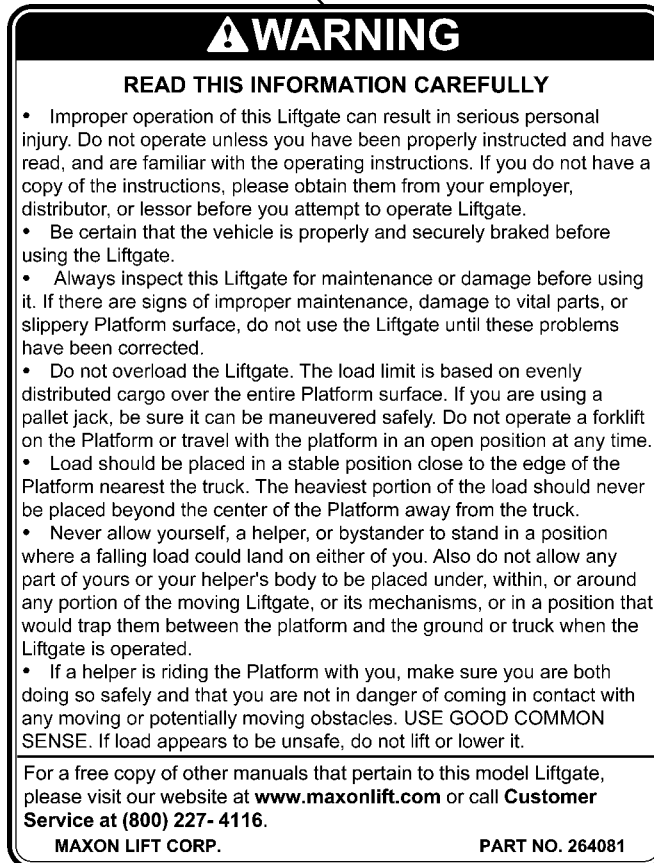

WARNING DECAL
P/N 264081

FIG. 34-1

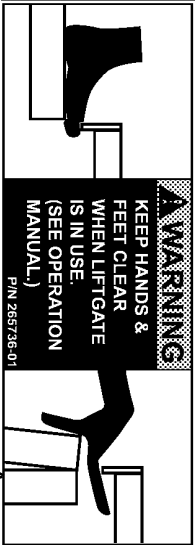

CAUTION DECAL
P/N 265736-01

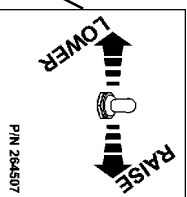

CONTROL SWITCH DECAL
P/N 264507

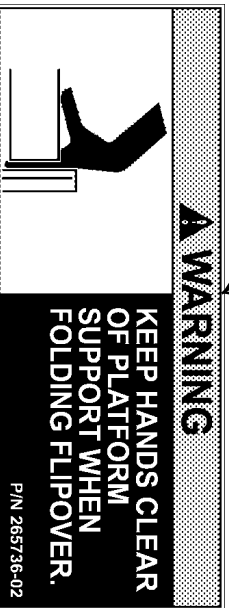
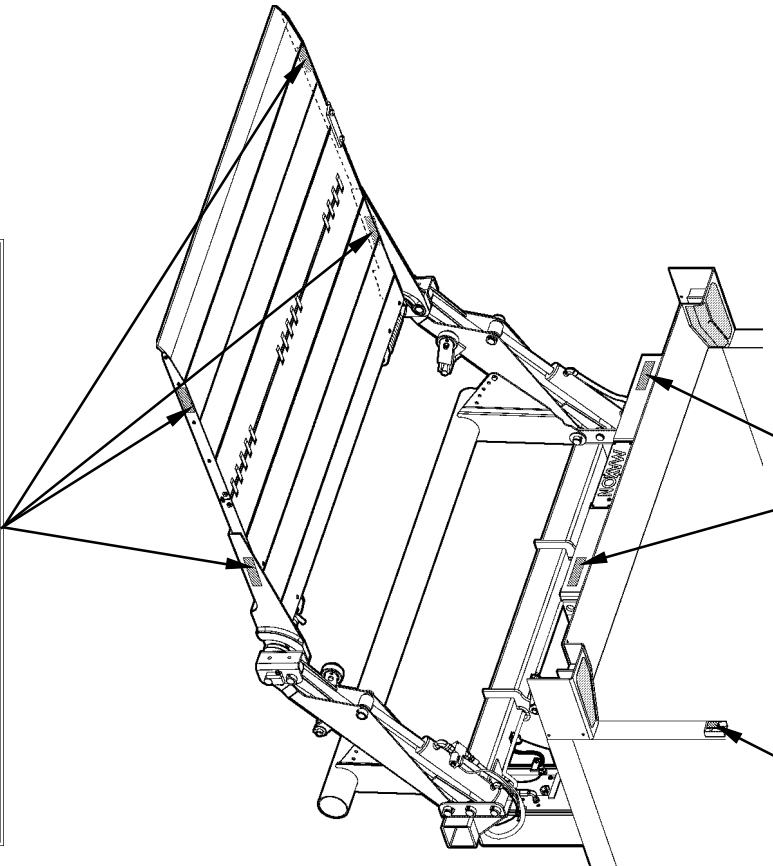

CAUTION DECAL
P/N 265736-02

NONSKID & SAFETY STRIPING

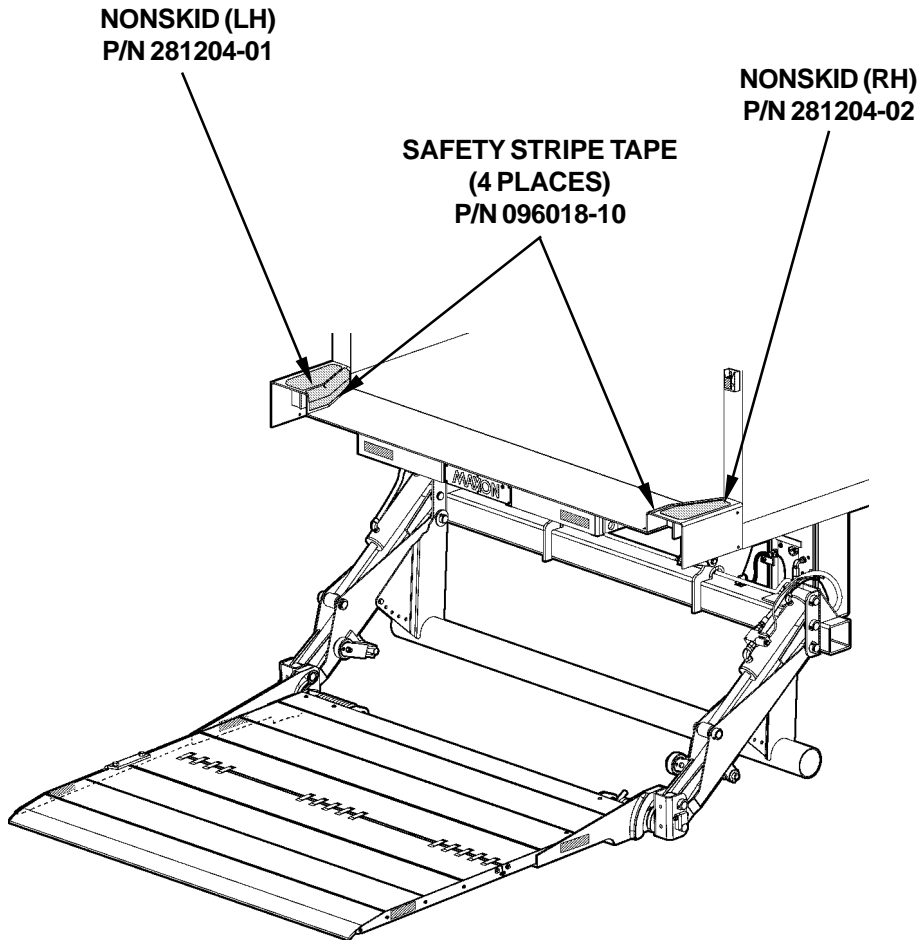

FIG. 36-1

MAXON[®]

11921 Slauson Ave. Santa Fe Springs, CA. 90670 (800) 227-4116 FAX (888) 771-7713

CONTROL SWITCH AND POWER CABLE

NOTE: Use Switch to **RAISE** and **LOWER** Liftgate to make sure Switch operates as shown on the decal.

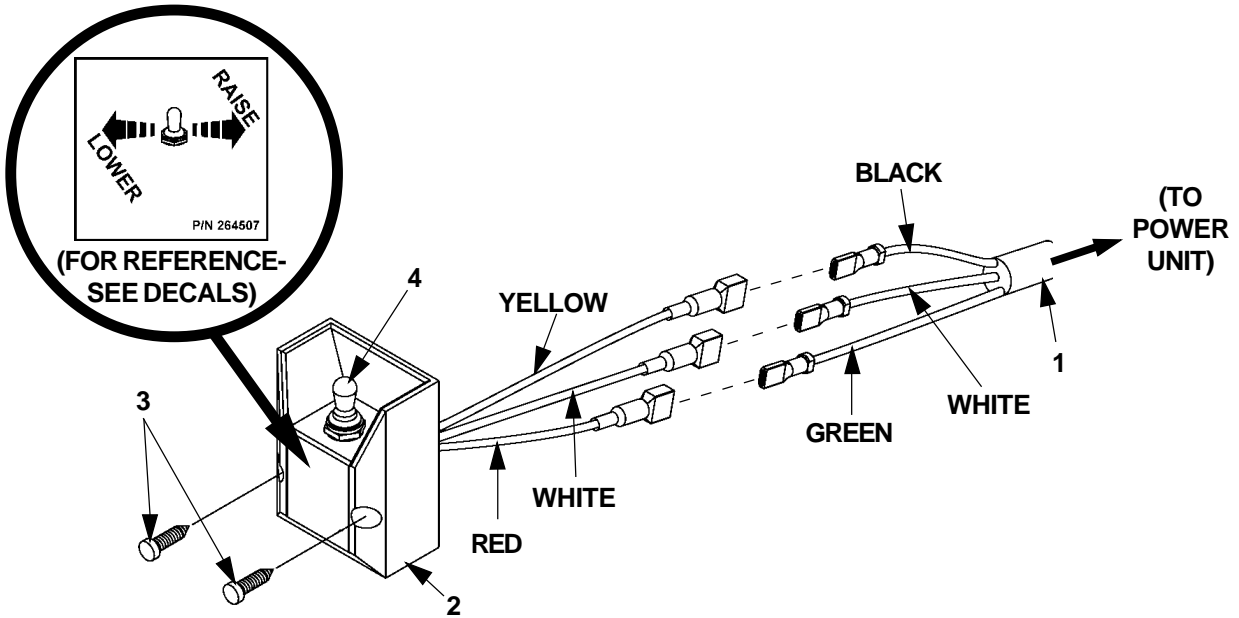

FIG. 37-1

ITEM	QTY.	PART NO.	DESCRIPTION
1	1	280637-01	HARNESS ASSEMBLY, 84" LG. (GRAVITY DOWN)
		280638-01	HARNESS ASSEMBLY, 84" LG. (POWER DOWN)
2	1	264346	SWITCH & CABLE
3	2	900057-5	SCREW, SELF-TAPPING #10-24 X 1" LG.
4	1	905206	SWITCH BOOT SEAL
5	1	264422	CABLE ASSEMBLY, 200 AMPS, 38' LG.
6	1	264687	KIT, MEGAFUSE (200 AMP FUSE & HEATSHRINK TUBING)

TABLE 37-1

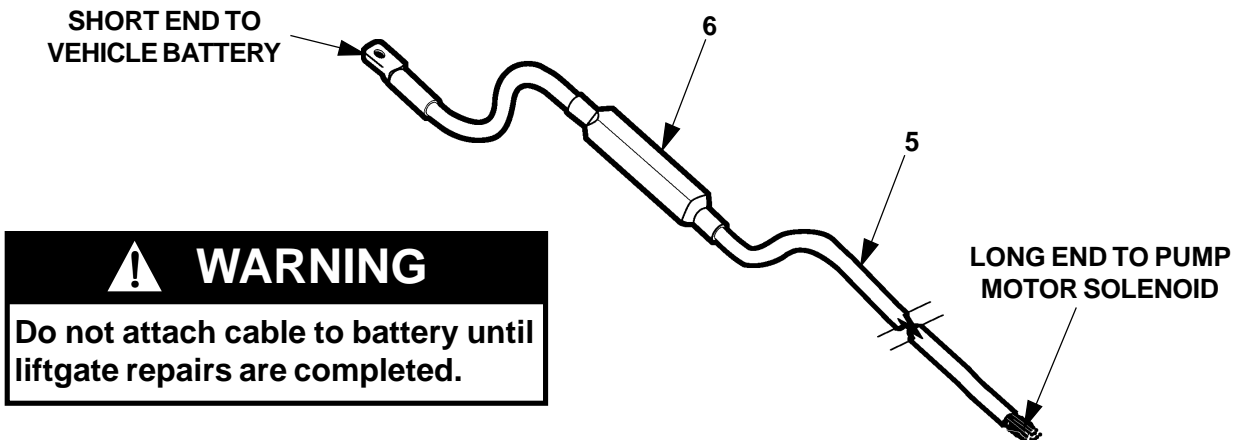

FIG. 37-2

HYDRAULIC SYSTEM DIAGRAMS

HYDRAULIC SCHEMATIC (GRAVITY DOWN)

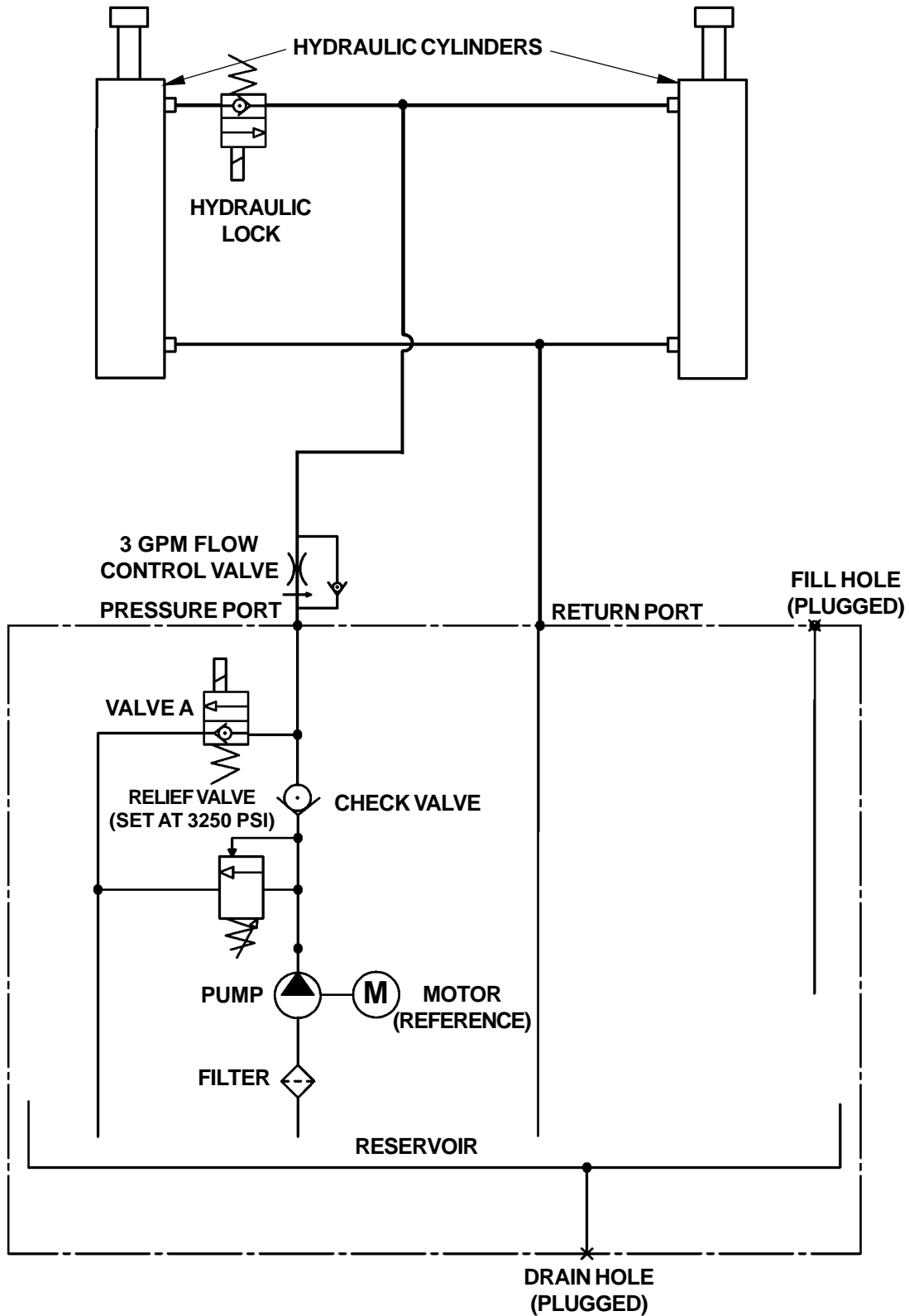

FIG. 38-1

MAXON®

11921 Slauson Ave. Santa Fe Springs, CA. 90670 (800) 227-4116 FAX (888) 771-7713

HYDRAULIC SYSTEM DIAGRAMS

HYDRAULIC SCHEMATIC (POWER DOWN)

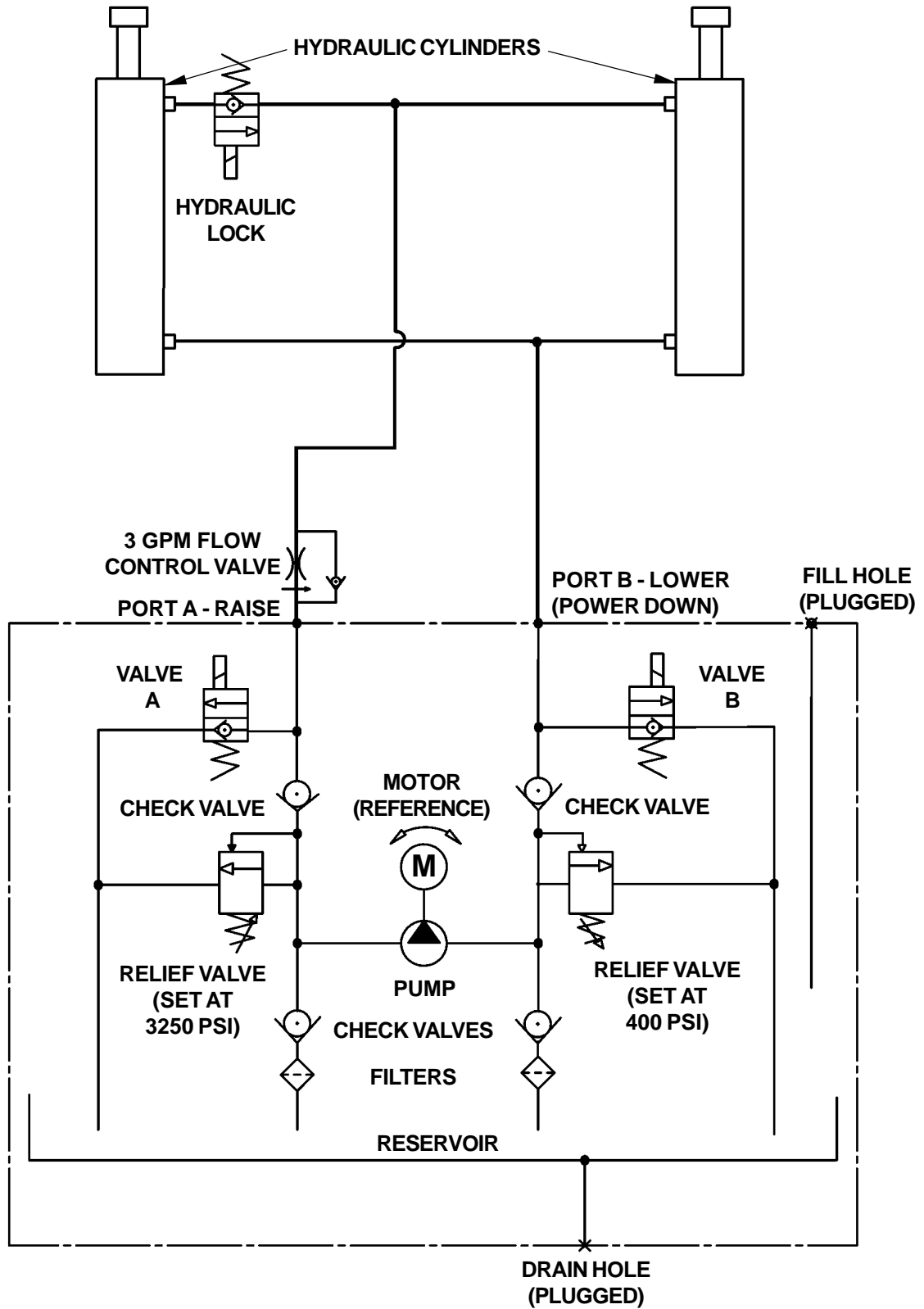

FIG. 39-1

ELECTRICAL SYSTEM DIAGRAMS

ELECTRICAL SCHEMATIC (GRAVITY DOWN)

MAXON®
 11921 Slauson Ave. Santa Fe Springs, CA. 90670 (800) 227-4116 FAX (888) 771-7713

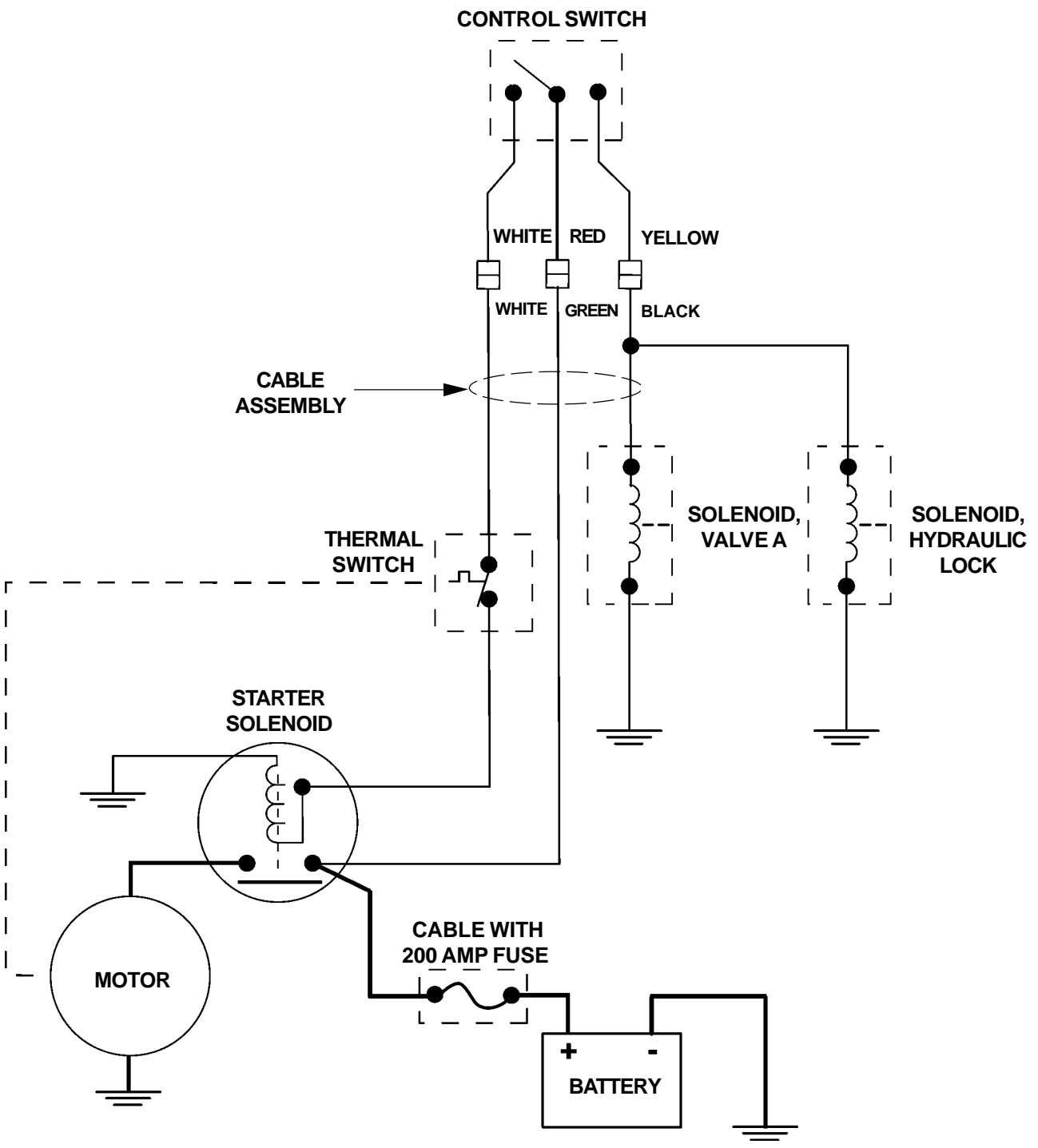

FIG. 40-1

ELECTRICAL SYSTEM DIAGRAMS

ELECTRICAL SCHEMATIC (POWER DOWN)

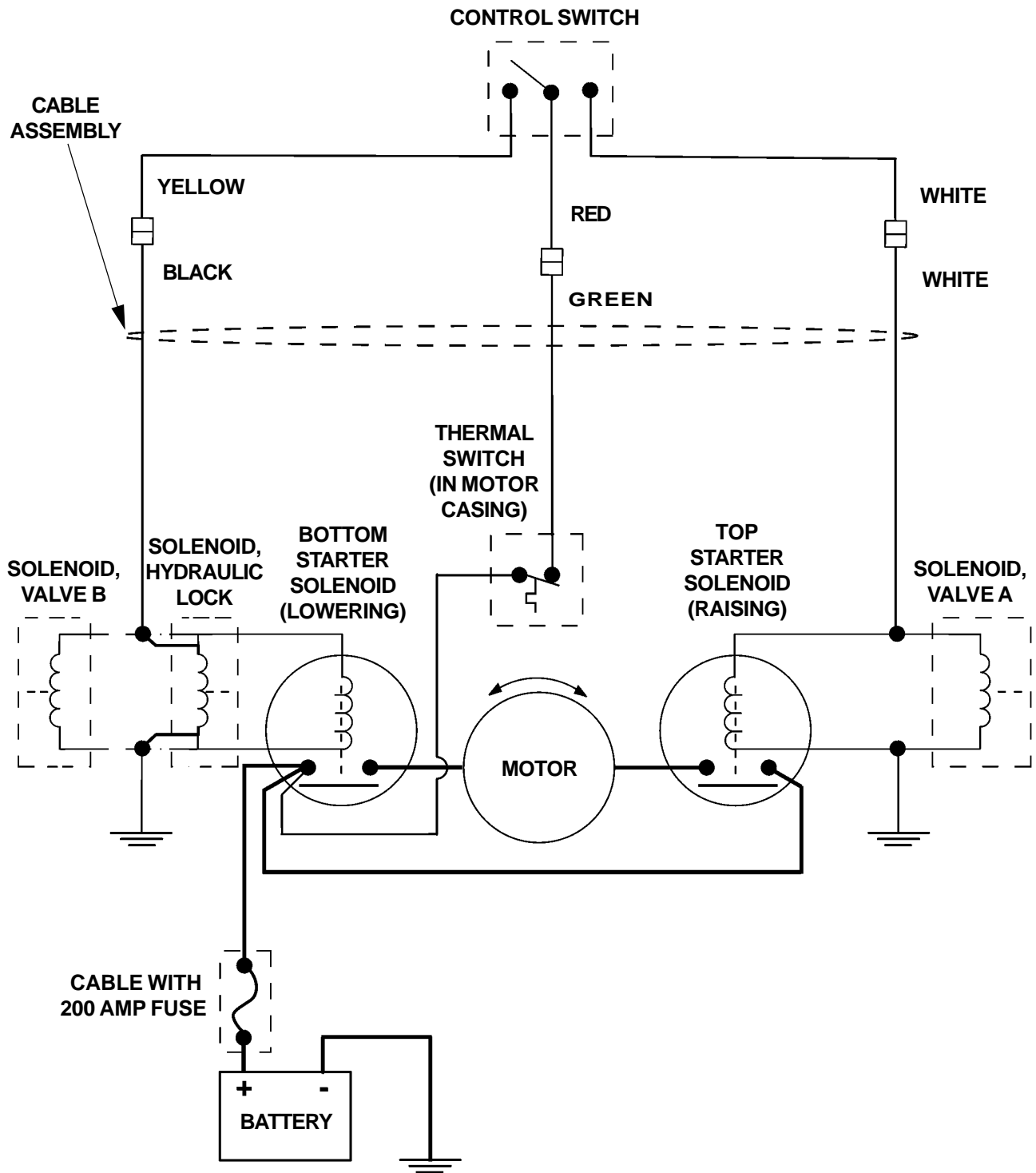

FIG. 41-1

RECOMMENDED BOLT TORQUES

CAUTION

The torque values in the following table are provided for torquing Grade 8 bolts on Liftgate mechanical parts. To prevent damage, never use the information in this table for torquing electrical or hydraulic hose connections on the Pump Assembly.

GRADE 8 BOLT TIGHTENING TORQUE	
DIAMETER & THREAD PITCH	TORQUE
1/4"-20	10-14 LBS.-FT.
1/4"-28	11-16 LBS.-FT.
5/16"-18	20-29 LBS.-FT.
5/16"-24	22-33 LBS.-FT.
3/8"-16	35-52 LBS.-FT.
3/8"-24	40-59 LBS.-FT.
7/16"-14	56-84 LBS.-FT.
7/16"-20	62-93 LBS.-FT.
1/2"-13	85-128 LBS.-FT.
1/2"-20	96-144 LBS.-FT.
9/16"-12	123-184 LBS.-FT.
9/16"-18	137-206 LBS.-FT.
5/8"-11	170-254 LBS.-FT.
5/8"-18	192-288 LBS.-FT.
3/4"-10	301-451 LBS.-FT.
3/4"-18	336-504 LBS.-FT.

TABLE 42-1

MAXON[®]

11921 Slauson Ave. Santa Fe Springs, CA. 90670 (800) 227-4116 FAX (888) 771-7713

TROUBLESHOOTING PLATFORM WILL NOT RAISE

1. Use voltmeter to verify that power is being supplied to Solenoid Terminal "A"
(FIG. 43-1.) Recharge the battery if less than 12.6 volts.

CAUTION

Keep dirt, water and other contaminants from entering the hydraulic system. Before opening the hydraulic fluid reservoir filler cap, drain plug and hydraulic lines, clean up contaminants that can get in the openings. Also, protect the openings from accidental contamination during maintenance.

2. Fill Reservoir to within 1/2" below the top with the hydraulic fluid recommended in the Periodic Maintenance Checklist.
3. Touch a jumper wire to terminals "B" & "C" (FIG. 43-1). If motor runs check Switch, switch connections, and White wire. Check and correct wiring connections or replace the Switch.
4. Touch heavy jumper cables to terminals "A" & "B" (FIG. 43-1).
 - a. If motor runs, replace the motor solenoid.
 - b. If motor does not run, repair or replace the pump motor.

NOTE: In most cases, you can avoid having to bleed the hydraulic system by correctly positioning Liftgate Platform before opening hydraulic lines. Refer to following procedure. Save time on the job and prevent accidental fluid spills and hazards.

5. Check for structural damage and replace worn parts.
6. Check filter in the pump Reservoir. Replace filter if necessary.
7. Check for dirty pump motor relief valve. Clean if necessary. Replace any worn out relief valve parts.

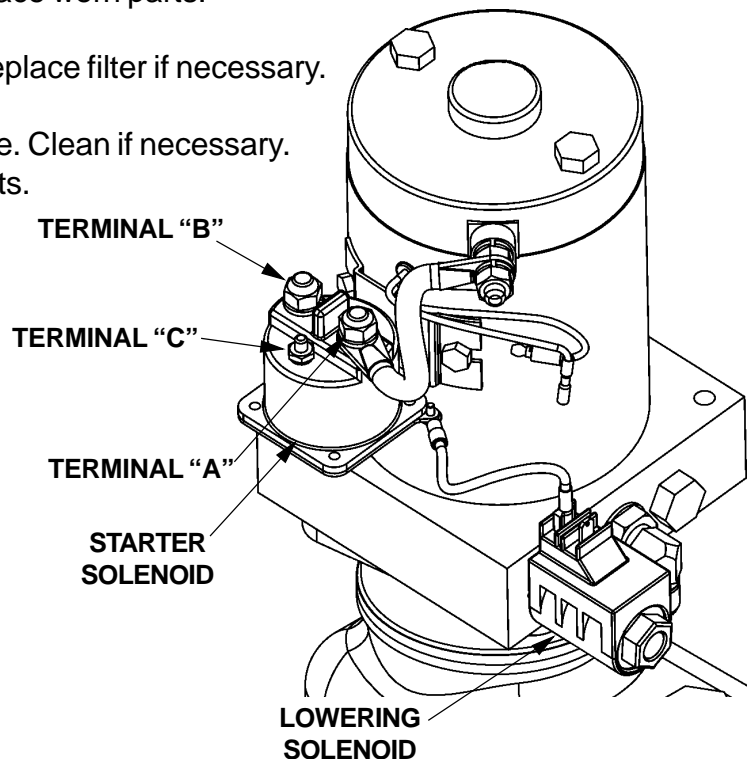

FIG. 43-1

TROUBLESHOOTING PLATFORM RAISES BUT LEAKS DOWN

1. Check if Solenoid Valves are constantly energized by touching a screwdriver to the top nut of the Solenoid (**FIG. 44-1**). Try pulling the screwdriver away from the solenoid. If the solenoid nut attracts the screwdriver (magnetically) without pushing the toggle switch, the control circuit is operating incorrectly. Check if toggle switch, wiring or coil are faulty.

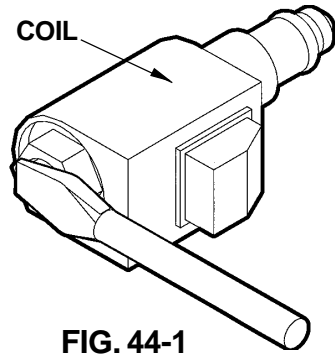

FIG. 44-1

CAUTION

Keep dirt, water and other contaminants from entering the hydraulic system. Before opening the hydraulic fluid reservoir filler cap, drain plug and hydraulic lines, clean up contaminants that can get in the openings. Also, protect the openings from accidental contamination during maintenance.

NOTE: In most cases, you can avoid having to manually bleed Hydraulic System by correctly positioning Liftgate Platform before disconnecting any Lifting Cylinder high pressure Hydraulic Lines. The following procedure can save time and prevent accidental fluid spills and hazards.

2. Check the Valve Stem by removing the Coil Assembly (**Item 1, FIG. 44-2**). With platform on ground, unscrew the Valve Stem, (**Item 2, FIG. 44-2**) from the Pump. Push on the plunger that is located inside the Valve Stem by inserting a small screwdriver blade in the end. If the Plunger does not move freely (approximately 1/8") replace the Valve Stem. **When re-installing valve stem, torque hex nut to 30 in-lbs.**

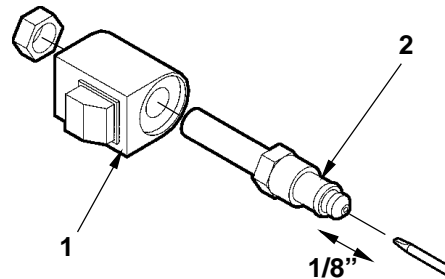

FIG. 44-2

3. Check the Hydraulic Cylinder. With the Platform on the ground, remove the hydraulic line from the Down Port of the Cylinder (**FIG. 44-3**). Raise the Platform even with the bed. Allow pump motor to run two seconds more while you watch for hydraulic fluid at the Down Port. A few drops of hydraulic fluid escaping the Down Port is normal; however, if it streams from the Down Port, Piston Seals are worn. Replace Seals.

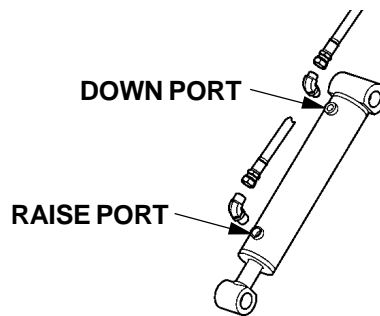

FIG. 44-3

PLATFORM RAISES PARTIALLY AND STOPS

CAUTION

Keep dirt, water and other contaminants from entering the hydraulic system. Before opening the hydraulic fluid reservoir filler cap, drain plug and hydraulic lines, clean up contaminants that can get in the openings. Also, protect the openings from accidental contamination during maintenance.

1. Lower the opened Platform to the ground. Fill the Pump Reservoir on Gravity-Down Liftgates to within 1/2" below the top with hydraulic fluid recommended in Periodic Maintenance Checklist.
2. Use voltmeter to verify that the Battery shows 12.6 volts or more.
3. Check for Structural damage, or poor lubrication. Replace worn parts.

NOTE: In most cases, you can avoid having to bleed the hydraulic system by correctly positioning Liftgate Platform before opening hydraulic lines. Refer to following procedure. Save time on the job and prevent accidental fluid spills and hazards.

4. Check the Hydraulic Cylinder. With the Platform on the ground, remove the Breather Plug or Vent Line from the Vent Port of the Cylinder (**FIG. 45-1**). Raise the Platform even with the bed. Allow pump motor to run two seconds more while you watch for hydraulic fluid at the Vent Port. A few drops of hydraulic fluid escaping the Vent Port is normal; however, if it streams from the Vent Port, Piston Seals are worn. Replace Seals.

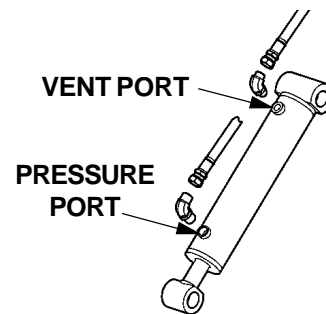

FIG. 45-1

5. Check Filter in the Pump Reservoir. Replace filter if necessary.
6. Check for dirty pump motor relief valve. Clean if necessary. Replace any worn out relief valve parts.

TROUBLESHOOTING

LIFTGATE WILL NOT LIFT RATED CAPACITY

1. Use voltmeter to verify that the Battery shows 12.6 volts or more under load from pump motor.
2. Check for Structural damage or lack of lubrication. Replace worn parts.

CAUTION

Keep dirt, water and other contaminants from entering the hydraulic system. Before opening the hydraulic fluid reservoir filler cap, drain plug and hydraulic lines, clean up contaminants that can get in the openings. Also, protect the openings from accidental contamination during maintenance.

NOTE: In most cases, you can avoid having to bleed the hydraulic system by correctly positioning Liftgate Platform before opening hydraulic lines. Refer to following procedure. Save time on the job and prevent accidental fluid spills and hazards.

3. With Platform on the ground, remove the pressure hose and fitting from the Pump and replace it with a 0-3000 PSI Pressure Gauge. Hold the switch in the "UP" position. Adjust the Relief Valve on the side of the Pump until the gauge shows 2800 to 3000 PSI (**FIG. 46-2**). Remove gauge and re-install pressure hose.
4. Check for dirty pump motor relief valve. Clean if necessary. Replace any worn out relief valve parts.
5. Check the Hydraulic Cylinder. With the Platform on the ground, remove the Breather Plug or Vent Line from the Vent Port of the Cylinder (**FIG. 46-1**). Raise the Platform even with the bed. Allow pump motor to run two seconds more while you watch for hydraulic fluid at the Vent Port. A few drops of hydraulic fluid escaping the Vent Port is normal; however, if it streams from the Vent Port, Piston Seals are worn. Replace Seals.
6. If Pump cannot produce 2800-3000 PSI with a minimum of 12.6 Volts available, the Pump is worn and needs to be replaced.

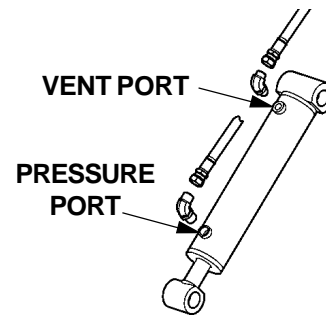

FIG. 46-1

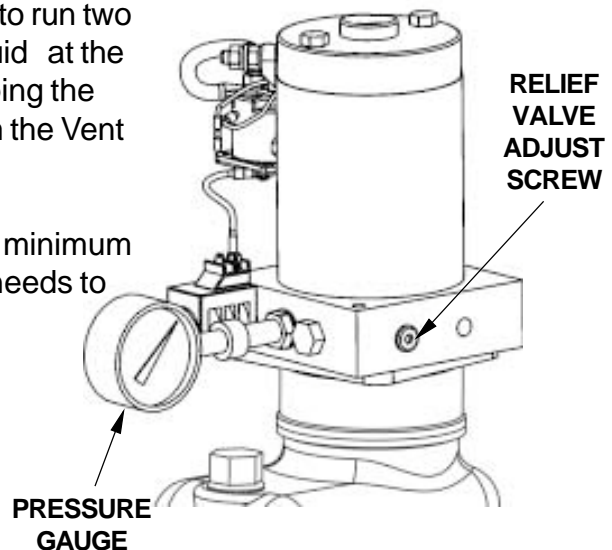

FIG. 46-2

PLATFORM RAISES SLOWLY

1. Use voltmeter to verify that power is being supplied to Solenoid Terminal "B". Recharge the battery if voltmeter indicates less than 12.6 Volts (**FIG. 47-1**).

CAUTION

Keep dirt, water and other contaminants from entering the hydraulic system. Before opening the hydraulic fluid reservoir filler cap, drain plug and hydraulic lines, clean up contaminants that can get in the openings. Also, protect the openings from accidental contamination during maintenance.

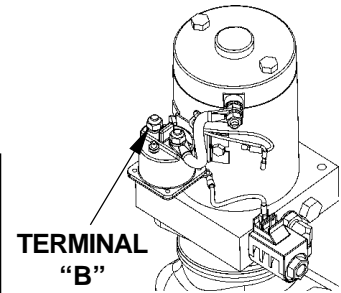

FIG. 47-1

2. Check the Hydraulic Cylinder. With the Platform on the ground, remove the Breather Plug or Vent Line from the Vent Port of the Cylinder (**FIG. 47-3**). Raise the Platform even with the bed. Allow pump motor to run two seconds more while you watch for hydraulic fluid at the Vent Port. A few drops of hydraulic fluid escaping the Vent Port is normal; however, if it streams from the Vent Port, Piston Seals are worn. Replace Seals.

NOTE: In most cases, you can avoid having to bleed the hydraulic system by correctly positioning Liftgate Platform before opening hydraulic lines. Refer to following procedure. Save time on the job and prevent accidental fluid spills and hazards.

3. Check and clean Flow Control Valve in high pressure hydraulic line attached to Pump Mounting Plate. When installing Flow Control Valve, make sure it is pointing to the direction of restricted fluid flow (pointing up and back toward pump) (**FIG. 47-3**).
4. Lower the opened Platform to the ground. Fill the Pump Reservoir on Gravity-Down Liftgates to within 1/2" below the top with hydraulic fluid recommended in Periodic Maintenance Checklist.
5. Verify the Pump Motor is grounded to vehicle frame. Make sure external tooth lock washer is installed under Pump mounting screw and flat washer (**FIG. 47-3**).

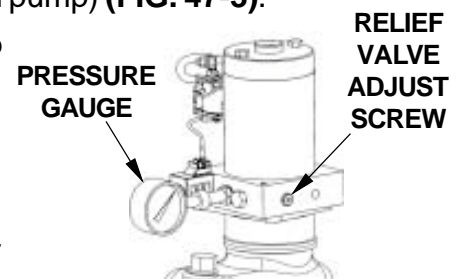

FIG. 47-2

6. Check for leaking hoses and fittings. Tighten or replace as required.
7. Check for structural damage or poor lubrication. Replace worn parts.
8. Check the Filter in the Pump Reservoir. Replace if necessary.
9. With Platform on the ground, remove the pressure hose and fitting from Pump and replace it with a 0-3000 PSI Pressure Gauge. Hold the Control Switch in the "RAISE" position. Adjust the Relief Valve on the side of the Pump until the gauge shows 2800 to 3000 PSI (**FIG. 47-2**). Remove gauge and reinstall pressure hose.

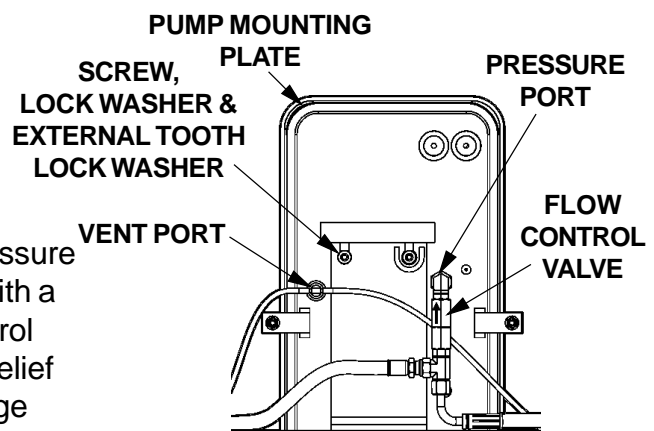

FIG. 47-3

TROUBLESHOOTING

PLATFORM WILL NOT LOWER, LOWERS TOO SLOWLY, OR LOWERS TOO QUICKLY

1. Use voltmeter to verify that power is being supplied to Solenoid Terminal "B". Recharge the battery if voltmeter indicates less than 12.6 Volts (**FIG. 48-1**).
2. Check for structural damage or poor lubrication. Replace worn parts.
3. Check if Solenoid Valve is getting power by holding a screwdriver against the top nut of the Solenoid. Push Control Switch to "**LOWER**" position to energize solenoid (**FIG. 48-2**). A good solenoid will attract (magnetically) the screwdriver to the nut and make it difficult to pull the screwdriver away from the nut.

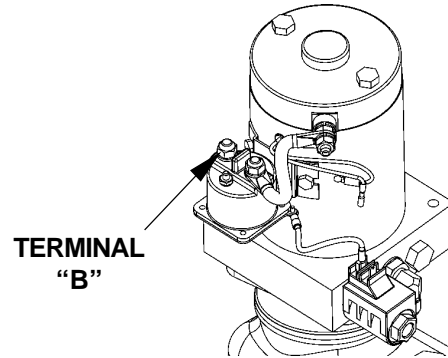

FIG. 48-1

CAUTION

Keep dirt, water and other contaminants from entering the hydraulic system. Before opening the hydraulic fluid reservoir filler cap, drain plug and hydraulic lines, clean up contaminants that can get in the openings. Also, protect the openings from accidental contamination during maintenance.

NOTE: In most cases, you can avoid having to bleed the hydraulic system by correctly positioning Liftgate Platform before opening hydraulic lines. Refer to following procedure. Save time on the job and prevent accidental fluid spills and hazards.

4. Check the Valve Stem by removing the Coil Assembly (**Item 1, FIG. 48-2**). With platform supported, unscrew the Valve Stem (**Item 2, FIG. 48-2**) from the Pump. Push on the plunger located inside the Valve Stem by inserting a small screwdriver blade in the end. If the Plunger does not move freely (approximately 1/8") replace the Valve Stem.
5. Check if filtering screen on solenoid valve is plugged. Clean carefully if required.
6. Check and clean Flow Control Valve in high pressure hydraulic line attached to Pump.
7. Check if Flow Control Valve (**FIG. 48-3**) is pointing to the direction of restricted fluid flow (pointing up and back toward pump). If required, remove Flow Control Valve and install it correctly (**FIG. 48-3**).

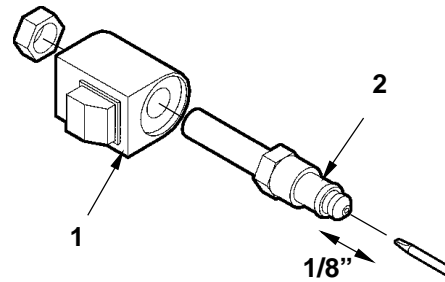

FIG. 48-2

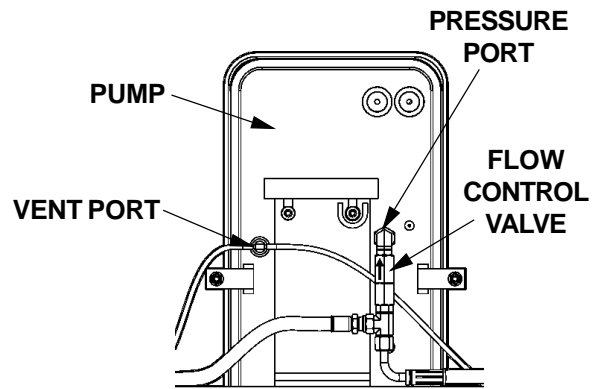

FIG. 48-3

