

M-07-13  
REV. P  
MAY 2014

**Installation Manual Contains:**

- Warnings & Safety Instructions
- Requirements - Body Strength & Installed Liftgate
- Liftgate Installation Components
- Liftgate Component Installation Instructions
- Hydraulic Fluid Filling Instructions
- Decals
- Hydraulic & Electrical System Diagrams
- Pre-delivery Inspection Form

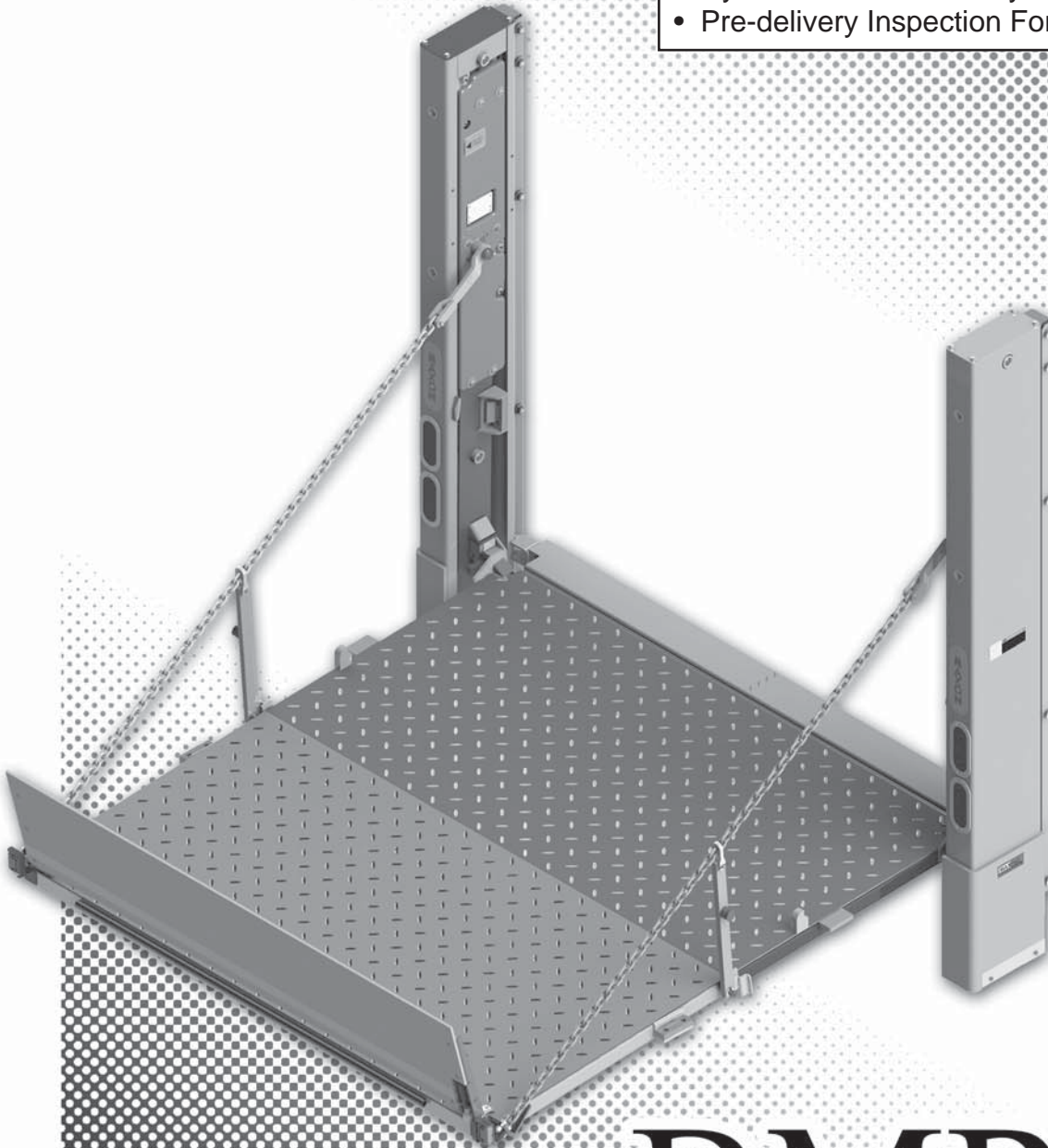

**MAXON<sup>®</sup>**  
**LIFT CORP.**

# BMRSD

## INSTALLATION MANUAL

# TABLE OF CONTENTS

|   |           |
|---|-----------|
| <b>SUMMARY OF CHANGES: M-07-13 REVISION P</b> .....       | <b>4</b>  |
| <b>WARNINGS</b> .....                                     | <b>5</b>  |
| <b>VEHICLE REQUIREMENTS</b> .....                         | <b>7</b>  |
| BODY STRENGTH.....  | 7         |
| INSTALLED LIFTGATE .....                                  | 9         |
| <b>LIFTGATE INSTALLATION COMPONENTS</b> .....             | <b>10</b> |
| <b>COMPONENTS</b> .....                                   | <b>11</b> |
| STEP 1 - PREPARE VEHICLE IF REQUIRED .....                | 13        |
| STEP 2 - CHOOSE METHOD OF INSTALLATION.....               | 15        |
| STEP 3 - POSITION LIFTGATE .....                          | 16        |
| PRE-INSTALL MOUNTING BRACKETS AND EXTENSION PLATE .....   | 16        |
| WELD LIFTGATE TO BODY.....                                | 20        |
| STEP 4 - BOLT LIFTGATE TO VEHICLE.....                    | 24        |
| STEP 5 - REMOVE LOWER SUPPORT FIXTURES .....              | 25        |
| STEP 6 - POSITION PUMP BOX FRAME .....                    | 26        |
| STEP 7 - ATTACH PUMP & BATTERY BOX FRAME TO VEHICLE ..... | 28        |
| STEP 8 - RUN HYDRAULIC LINES & ELECTRIC CABLES.....       | 33        |
| RUN HYDRAULIC LINES.....                                  | 34        |
| RUN ELECTRIC CABLES .....                                 | 36        |
| STEP 9 - CONNECT GROUND CABLE .....                       | 37        |
| GROUNDING TO TRUCK FRAME.....                             | 37        |
| GROUNDING TO BATTERY BOX (IF EQUIPPED).....               | 38        |
| STEP 10 - INSTALL CONTROL BOX & BRACKET .....             | 39        |
| STEP 11 - RUN CHARGE LINES.....                           | 40        |
| STEP 12 - CONNECT BATTERIES TO LIFTGATE .....             | 41        |

## TABLE OF CONTENTS - Continued

|   |           |
|---|-----------|
| STEP 13 - ADD HYDRAULIC FLUID TO RESERVOIR .....    | 42        |
| STEP 14 - PRESSURIZE HYDRAULIC SYSTEM .....         | 43        |
| STEP 15 - OPTIMIZE HYDRAULIC FLUID LEVEL.....       | 44        |
| STEP 16 - FINISH WELDING LIFTGATE TO VEHICLE .....  | 47        |
| STEP 17 - PLATFORM CHAIN ADJUSTMENT .....           | 52        |
| STEP 18 - REMOVE UPPER SUPPORT FIXTURES .....       | 54        |
| STEP 19 - PLACE "ALIGN ARROWS" DECAL.....           | 55        |
| STEP 20 - ADJUST PLATFORM ASSEMBLY .....            | 56        |
| STEP 21 - ACTIVATE PLATFORM LIGHTS.....             | 57        |
| ATTACH DECALS .....                                 | 58        |
| <b>TOUCHUP PAINTED OR GALVANIZED FINISH .....</b>   | <b>60</b> |
| <b>OPTIONS .....</b>                                | <b>61</b> |
| RECOMMENDED LIFTGATE POWER CONFIGURATION .....      | 61        |
| <b>HYDRAULIC SYSTEM DIAGRAMS.....</b>               | <b>65</b> |
| PUMP & MOTOR SOLENOID OPERATION - POWER DOWN.....   | 65        |
| PUMP & MOTOR SOLENOID OPERATION - GRAVITY DOWN..... | 66        |
| SINGLE PUMP BOX HYDRAULIC SCHEMATIC.....            | 67        |
| DUAL PUMP BOX HYDRAULIC SCHEMATIC .....             | 68        |
| <b>ELECTRICAL SYSTEM DIAGRAMS .....</b>             | <b>69</b> |
| INTERCONNECTING ELECTRICAL SCHEMATIC.....           | 69        |
| SINGLE PUMP BOX ELECTRICAL SCHEMATIC .....          | 70        |
| DUAL PUMP BOX ELECTRICAL SCHEMATIC .....            | 71        |
| <b>PRE-DELIVERY INSPECTION FORM.....</b>            | <b>72</b> |

# SUMMARY OF CHANGES: M-07-13 REVISION P

| PAGE  | DESCRIPTION OF CHANGE   |
|-------|---|
| COVER | Updated REV and date of release and copyright date  |
| 4     | Added SUMMARY OF CHANGES  |
| 21    | Updated STEP 3, initial bolt torque specs for both stainless and standard steel brackets. Moved flat washers to bolt-head side of brackets. |
| 22    | Updated decal P/N 260293  |
| 24    | Updated STEP 4, final bolt torque specs for both stainless and standard steel brackets. Moved flat washers to bolt-head side of brackets.   |
| 48    | Updated STEP 16, final bolt torque specs for stainless and standard steel brackets  |
|       |   |
|       |   |
|       |   |
|       |   |
|       |   |
|       |   |
|       |   |
|       |   |
|       |   |

**MAXON**<sup>®</sup> 11921 Slauson Ave. Santa Fe Springs, CA. 90670 (800) 227-4116 FAX (888) 771-7713

Comply with the following **WARNINGS** and **SAFETY INSTRUCTIONS** while installing Liftgates. See Operation Manual for operating safety requirements.

## **⚠ WARNING**

- Do not stand, or allow obstructions, under the platform when lowering the Liftgate. **Be sure your feet are clear of the Liftgate.**
- **Keep fingers, hands, arms, legs, and feet clear of moving Liftgate parts (and platform edges) when operating the Liftgate.**
- **Correctly stow platform when not in use. Extended platforms could create a hazard for people and vehicles passing by.**
- **Make sure vehicle battery power is disconnected** while installing Liftgate. Connect vehicle battery power to the Liftgate only when installation is complete or as required in the installation instructions.
- **Remove all rings, watches and jewelry before doing any electrical work.**
- If it is necessary to stand on the platform while operating the Liftgate, keep your feet and any objects clear of the inboard edge of the platform. Your feet or objects on the platform can become trapped between the platform and the Liftgate extension plate.
- Never perform unauthorized modifications on the Liftgate. Modifications may result in early failure of the Liftgate and may create hazards for Liftgate operators and maintainers.
- Recommended practices for welding on steel parts are contained in the current **AWS (American Welding Society) D1.1 Structural Welding Code - Steel**. Damage to Liftgate and/or vehicle, and personal injury can result from welds that are done incorrectly.
- Welding on galvanized parts gives off especially hazardous fumes. Comply with WARNING decal on the galvanized part (**FIG. 5-1**). To minimize hazard remove galvanizing from weld area, provide adequate ventilation, and wear suitable respirator.

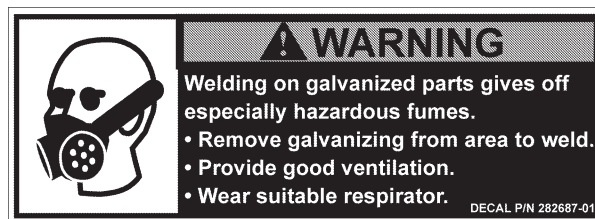

**FIG. 5-1**



## SAFETY INSTRUCTIONS

- Read and understand the instructions in this **Installation Manual** before installing Liftgate.
- Before operating the Liftgate, read and understand the operating instructions in **Operation Manual**.
- Comply with all **WARNING** and instruction decals attached to the Liftgate.
- Keep decals clean and legible. If decals are illegible or missing, replace them. Free replacement decals are available from **Maxon Customer Service**.
- Consider the safety and location of bystanders and location of nearby objects when operating the Liftgate. Stand to one side of the platform while operating the Liftgate.
- Do not allow untrained persons or children to operate the Liftgate.
- Wear appropriate safety equipment such as protective eyeglasses, faceshield and clothing while performing maintenance on the Liftgate and handling the battery. Debris from drilling and contact with battery acid may injure unprotected eyes and skin.
- Be careful working by an automotive type battery. Make sure the work area is well ventilated and there are no flames or sparks near the battery. Never lay objects on the battery that can short the terminals together. If battery acid gets in your eyes, immediately seek first aid. If acid gets on your skin, immediately wash it off with soap and water.
- If an emergency situation arises (vehicle or Liftgate) while operating the Liftgate, release the control switch to stop the Liftgate.
- A correctly installed Liftgate operates smoothly and reasonably quiet. The only noticeable noise during operation comes from the power unit while the platform is raised and lowered. Listen for scraping, grating and binding noises and correct the problem before continuing to operate Liftgate.

# VEHICLE REQUIREMENTS

**NOTE:** Installer is responsible for ensuring vehicle meets Federal, State, and Local standards and regulations.

## BODY STRENGTH

### ⚠ WARNING

Consult vehicle body manufacturer for vehicle body strength data. Make sure the forces created by the Liftgate are within the limits prescribed by the vehicle body manufacturer.

**NOTE:** Maximum operating bed height for body is **56" (Unloaded)**. Minimum is **32" (Loaded)**. Do not install this Liftgate on vehicle bodies equipped with swing open doors.

The BMRSD is a body-mounted Liftgate that puts forces on the side walls of truck and trailer bodies (**FIG. 7-1**). For correct installation, truck and trailer bodies must be strong enough to withstand the tension, compression and shear forces shown in **FIG. 7-1**. Use **TABLES 8-1, 8-2, 8-3, and 8-4** on the following page to determine the forces that apply to the type of platform, size of platform, and load capacity of your Liftgate.

**X= Tension on each sidewall**  
**Y= Compression on each sidewall**  
**Z= Shear on each sidewall**

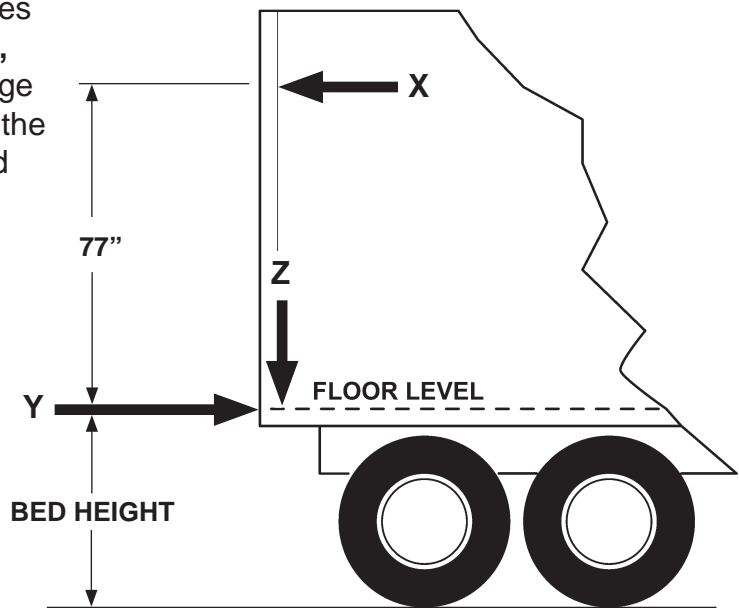

**FIG. 7-1**

## VEHICLE REQUIREMENTS - Continued

### BODY STRENGTH - Continued

| MODEL CAPACITY                                   | P/F SIZE | (X)(Y) LBS. | (Z) LBS. |
|--|----------|-------------|----------|
| <b>BMR-35<br/>3500 LBS.<br/>(STEEL PLATFORM)</b> | 84       | 2101        | 4176     |
|  | 72       | 1780        | 4071     |
|  | 60       | 1475        | 3962     |
|  | 48       | 1180        | 3840     |
|  | 42       | 1043        | 3786     |
| <b>BMR-44<br/>4400 LBS.<br/>(STEEL PLATFORM)</b> | 84       | 2504        | 4851     |
|  | 72       | 2110        | 4746     |
|  | 60       | 1772        | 4637     |
|  | 48       | 1426        | 4515     |
|  | 42       | 1262        | 4461     |

**TABLE 8-1**

| MODEL CAPACITY                                   | P/F SIZE | (X)(Y) LBS. | (Z) LBS. |
|--|----------|-------------|----------|
| <b>BMR-55<br/>5500 LBS.<br/>(STEEL PLATFORM)</b> | 84       | 2998        | 5676     |
|  | 72       | 2559        | 5571     |
|  | 60       | 2137        | 5462     |
|  | 48       | 1726        | 5340     |
|  | 42       | 1529        | 5286     |
| <b>BMR-66<br/>6600 LBS.<br/>(STEEL PLATFORM)</b> | 84       | 3491        | 6501     |
|  | 72       | 2989        | 6396     |
|  | 60       | 2500        | 6287     |
|  | 48       | 2025        | 6165     |
|  | 42       | 1738        | 6111     |

**TABLE 8-2**

| MODEL CAPACITY                                      | P/F SIZE | (X)(Y) LBS. | (Z) LBS. |
|---|----------|-------------|----------|
| <b>BMR-35<br/>3500 LBS.<br/>(ALUMINUM PLATFORM)</b> | 84       | 1785        | 3683     |
|   | 72       | 1580        | 3649     |
|   | 60       | 1339        | 3619     |
|   | 48       | 1081        | 3533     |
|   | 42       | 964         | 3510     |
| <b>BMR-44<br/>4400 LBS.<br/>(ALUMINUM PLATFORM)</b> | 84       | 2233        | 4358     |
|   | 72       | 1931        | 4324     |
|   | 60       | 1637        | 4294     |
|   | 48       | 1326        | 4208     |
|   | 42       | 1183        | 4185     |

**TABLE 8-3**

| MODEL CAPACITY                                      | P/F SIZE | (X)(Y) LBS. | (Z) LBS. |
|---|----------|-------------|----------|
| <b>BMR-55<br/>5500 LBS.<br/>(ALUMINUM PLATFORM)</b> | 84       | 2725        | 5183     |
|   | 72       | 2360        | 5749     |
|   | 60       | 2001        | 5119     |
|   | -        | -           | -        |
|   | -        | -           | -        |
| <b>BMR-66<br/>6600 LBS.<br/>(ALUMINUM PLATFORM)</b> | 84       | 3219        | 6008     |
|   | 72       | 2788        | 5974     |
|   | 60       | 2365        | 5944     |
|   | -        | -           | -        |
|   | -        | -           | -        |

**TABLE 8-4**



# VEHICLE REQUIREMENTS - Continued

## INSTALLED LIFTGATE

**NOTE:** If Liftgate columns exceed a 91 degree angle from level ground when installed on body, or if columns cannot be mounted flush against rear of vehicle, a steel filler may be used to bridge gap between vehicle body and Liftgate columns. Make sure the added materials and welds meet the **BODY STRENGTH** requirements shown on the previous pages.

With the vehicle parked on level ground, the columns of the BMRSD must be perpendicular to the ground (vertical) for the Liftgate to operate correctly (FIGS. 9-1 and 9-2).

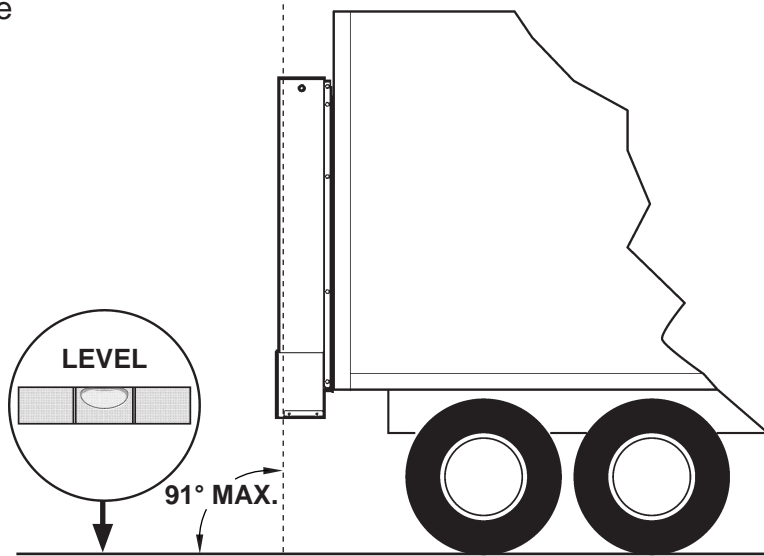

LIFTGATE INSTALLED ON VAN BODY (COLUMNS SHOWN PERPENDICULAR TO LEVEL GROUND)

FIG. 9-1

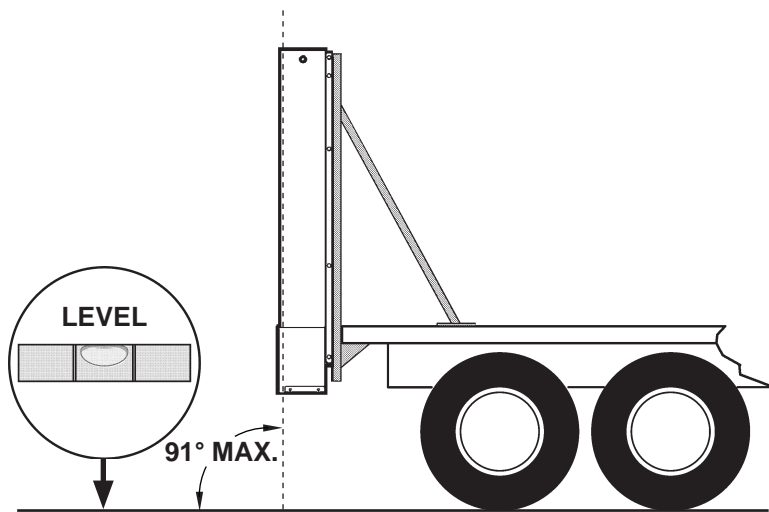

LIFTGATE INSTALLED ON FLAT BED (COLUMNS & SUPPORTS SHOWN PERPENDICULAR TO LEVEL GROUND)

FIG. 9-2

# LIFTGATE INSTALLATION COMPONENTS

Each BMRSD Liftgate includes items shown in FIG. 10-1.

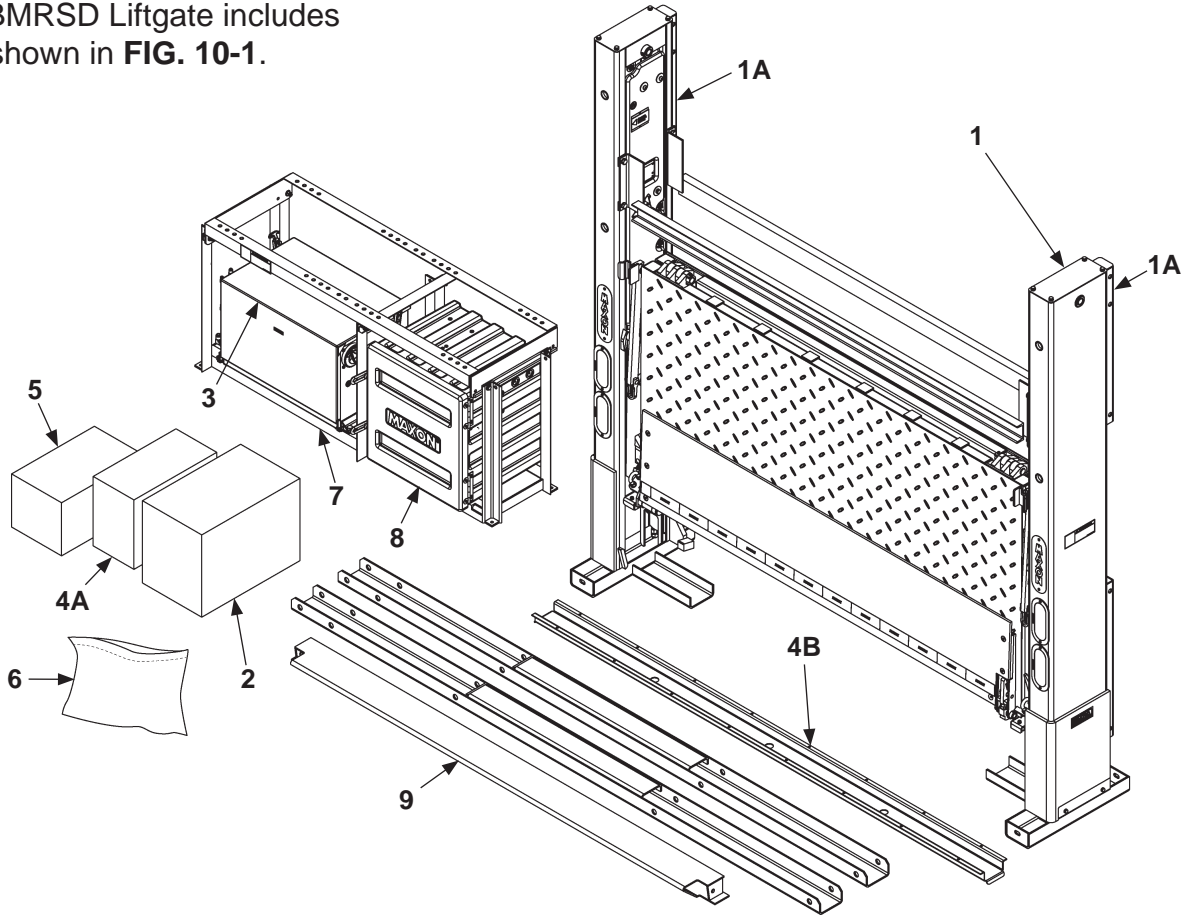

FIG. 10-1

| DESCRIPTION |   |
|-------------|---|
| 1           | BMRSD Liftgate  |
| 1A          | Mounting brackets   |
| 2           | Hardware parts bag, mounting bracket parts bag, hydraulic lines & fittings, wiring harness, power cable, molded switch control box                |
| 3           | Pump box assembly   |
| 4A          | Installation kit (3', 10', 15', 20' or 28')   |
| 4B          | Channel guards (for 10', 15', 20' or 28' installation kits only)  |
| 5           | Optional equipment  |
| 6           | Instruction manuals and decals  |
| 7           | Frame for pump box with optional battery box is shown. A shorter frame is also available for mounting single pump box or an optional battery box. |
| 8           | Battery box (optional)  |
| 9           | Mounting channels and extension plate kit   |

TABLE 10-1

# COMPONENTS

**NOTE:** Make sure you have components and parts before you start installing Liftgate. Compare parts in the part box and each kit box with packing list enclosed in each box. If parts and components are missing or incorrect, call:

**Maxon Customer Service**  
**Call (800) 227-4116 or**  
**Send e-mail to [cservice@maxonlift.com](mailto:cservice@maxonlift.com)**

| BMRSD MODEL | FIELD MOUNTING KIT, STNL-STEEL CH | FIELD MOUNTING KIT, STEEL CH     | MANUAL & DECAL KIT | PART BOX  | 3 FT PUMP BOX INSTALL KIT | 10 FT PUMP BOX INSTALL KIT | 15 FT PUMP BOX INSTALL KIT | 20 FT PUMP BOX INSTALL KIT | 28 FT PUMP BOX INSTALL KIT |
|-------------|-----------------------------------|----------------------------------|--------------------|-----------|---------------------------|----------------------------|----------------------------|----------------------------|----------------------------|
| BMRSD 35 PD | 284502-01<br>(96" WIDE VEHICLE)   | 284502-03<br>(96" WIDE VEHICLE)  | 268347-01          | 284505-01 | 268346-01                 | 268346-02                  | 268346-15                  | 268346-03                  | 268346-04                  |
| BMRSD 44 PD |                                   |                                  | 268347-02          |           |                           |                            |                            |                            |                            |
| BMRSD 55 PD |                                   |                                  | 268347-03          |           |                           |                            |                            |                            |                            |
| BMRSD 66 PD |                                   |                                  | 268347-04          |           |                           |                            |                            |                            |                            |
|             | 284502-02<br>(102" WIDE VEHICLE)  | 284502-04<br>(102" WIDE VEHICLE) |                    |           |                           |                            |                            |                            |                            |

**TABLE 11-1**

| BMRSD MODEL | OPTIONS          |                |                              |                             |  |               |                         |                                      |                           |
|-------------|------------------|----------------|------------------------------|-----------------------------|--|---------------|-------------------------|--------------------------------------|---------------------------|
|             | SINGLE PUMP ASSY | DUAL PUMP ASSY | FRAME, PUMP OR BATTERY BOXES | FRAME, PUMP & BATTERY EDGES | LOW VOLTAGE SWITCH (1 KIT FOR SINGLE PUMP, 2 KITS FOR DUAL PUMP) | CYCLE COUNTER | HEADER KIT (ADJUSTABLE) | HEADER KIT LIGHT MOUNT               | DOMELAMP RECESSED - MOUNT |
| BMRSD 35 PD | 283310-01        | 283080-01      | 285554-11<br>(PAINTED)       | 285720-11<br>(PAINTED)      | 267923-01  | 280590-01     | 263490<br>(PAINTED)     | 268860-01<br>(96" WIDE, PAINTED)     | 906589-01                 |
| BMRSD 44 PD |                  |                | 285554-11G<br>(GALVANIZED)   | 285720-11G<br>(GALVANIZED)  |  |               | 263490G<br>(GALVANIZED) | 268860-01G<br>(96" WIDE, GALVANIZED) |                           |
| BMRSD 55 PD |                  |                |                              |                             |  |               |                         |                                      |                           |
| BMRSD 66 PD |                  |                |                              |                             |  |               |                         |                                      |                           |

**TABLE 11-2**

| BMRSD MODEL | OPTIONS     |                |                                   |                             |  |                   |                   |
|-------------|-------------|----------------|-----------------------------------|-----------------------------|--|-------------------|-------------------|
|             | BATTERY BOX | BATTERY 12V HD | KIT, TOUCHUP PAINT WITH AL PRIMER | HYDRAULIC OIL UNIVIS HV1-13 | NON-SKID COATING                             | AUXILIARY CONTROL | HAND HELD CONTROL |
| BMRSD 35 PD | 269560-01   | 267318-01      | 908134-01                         | 284098-01                   | 281531-100<br>(NOT FOR GALVANIZED PLATFORMS) | 266070-03         | 263260-08         |
| BMRSD 44 PD |             |                |                                   |                             |  |                   |                   |
| BMRSD 55 PD |             |                |                                   |                             |  |                   |                   |
| BMRSD 66 PD |             |                |                                   |                             |  |                   |                   |

**TABLE 11-3**

**MAXON**<sup>®</sup> 11921 Slauson Ave. Santa Fe Springs, CA. 90670 (800) 227-4116 FAX (888) 771-7713

# COMPONENTS - Continued

| BMRSD MODEL | CHARGE LINE OPTIONS     |                       |                                 |                               |                                      |                                       |                                   |                       |
|-------------|-------------------------|-----------------------|---------------------------------|-------------------------------|--------------------------------------|---------------------------------------|-----------------------------------|-----------------------|
|             | SINGLE POLE TRACTOR KIT | DUAL POLE TRACTOR KIT | SINGLE POLE TRAILER CHARGE LINE | DUAL POLE TRAILER CHARGE LINE | ADAPT DUAL & SINGLE POLE TRACTOR KIT | TRAILER SINGLE/DUAL POLE NOSE BOX KIT | BATTERY STATE OF CHARGE INDICATOR | BATTERY INDICATOR KIT |
| BMRSD 35 PD | 280275-03               | 280275-04             | 280275-01                       | 280275-02                     | 280275-05                            | 280275-06                             | 908171-01                         | LG-TBI                |
| BMRSD 44 PD |                         |                       |                                 |                               |                                      |                                       |                                   |                       |
| BMRSD 55 PD |                         |                       |                                 |                               |                                      |                                       |                                   |                       |
| BMRSD 66 PD |                         |                       |                                 |                               |                                      |                                       |                                   |                       |

**TABLE 12-1**

| BMRSD MODEL | CHARGE LINE OPTIONS   |                        |                       |                           |                              |                              |                       |   |
|-------------|-----------------------|------------------------|-----------------------|---------------------------|------------------------------|------------------------------|-----------------------|---|
|             | TC-4 KIT WITH SEL-BOX | TC-5 KIT WITH EXTENDER | TC-6 KIT WITH LOCKOUT | TC-7 KIT DUAL-SINGLE POLE | TC-8 KIT 3-IN-1 WITH LOCKOUT | TC-9 KIT 2-IN-1 WITH LOCKOUT | TC-10 KIT WITH MODULE | TC-11 KIT RETROFIT EXTEND SINGLE/ DUAL POLE |
| BMRSD 35 PD | 284582-01             | 283531-01              | 283040-01             | 284424-01                 | 283821-01                    | 284585-01                    | 284550-01             | 284587-01                                   |
| BMRSD 44 PD |                       |                        |                       |                           |                              |                              |                       |   |
| BMRSD 55 PD |                       |                        |                       |                           |                              |                              |                       |   |
| BMRSD 66 PD |                       |                        |                       |                           |                              |                              |                       |   |

**TABLE 12-2**

**MAXON**<sup>®</sup> 11921 Slauson Ave. Santa Fe Springs, CA. 90670 (800) 227-4116 FAX (888) 771-7713

# STEP 1 - PREPARE VEHICLE IF REQUIRED

**NOTE:** Perform the following step for flatbed vehicle body only. If vehicle body is not a flatbed, skip this step.

**NOTE:** LH and RH supports must be perpendicular to level ground. See **VEHICLE REQUIREMENTS, INSTALLED LIFTGATE.**

**NOTE:** Materials for support framework are not provided with Liftgate.

## ⚠ WARNING

Recommended practices for welding on steel parts are contained in the current AWS (American Welding Society) D1.1 Structural Welding Code - Steel. Damage to Liftgate and/or vehicle, and personal injury can result from welds that are done incorrectly.

1. Fabricate framework, as shown in **FIGS. 13-1A, -1B & -1C**, to support Liftgate on a flatbed vehicle. Then, go to the next page for welding instructions.

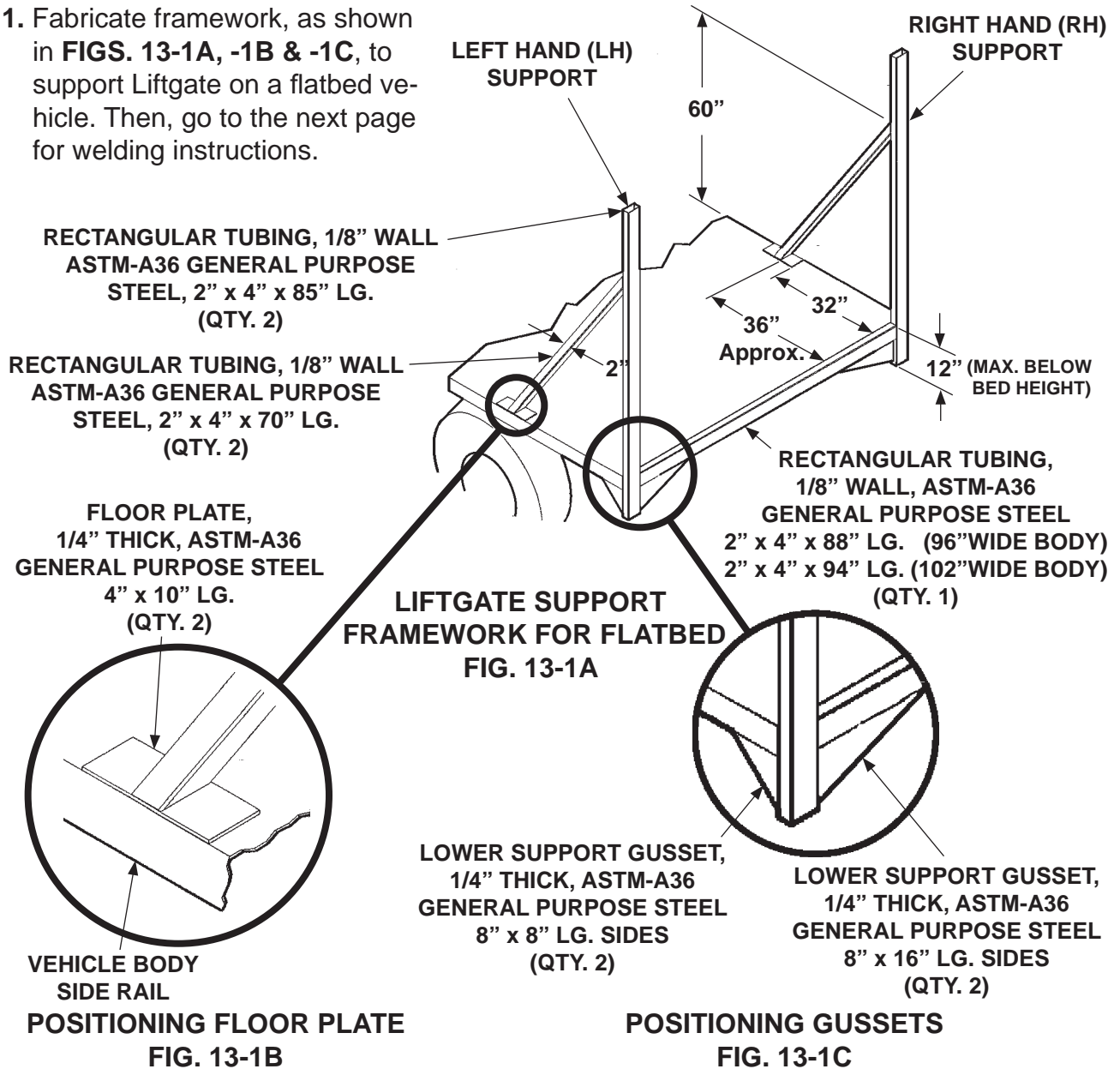





## STEP 2 - CHOOSE METHOD OF INSTALLATION

**NOTE:** MAXON recommends pre-installing the extension plate, column mounting brackets, and control box bracket on the vehicle body before installing the Liftgate.

Two methods for mounting a BMRSD Liftgate on a vehicle body are covered in this manual.

**Method 1** - Column mounting brackets, extension plate, and external switch bracket can be welded to vehicle body before bolting on the Liftgate (**FIG. 15-1**). Refer to the **PRE-INSTALL MOUNTING BRACKETS AND EXTENSION PLATE** instructions in **STEP 3**.

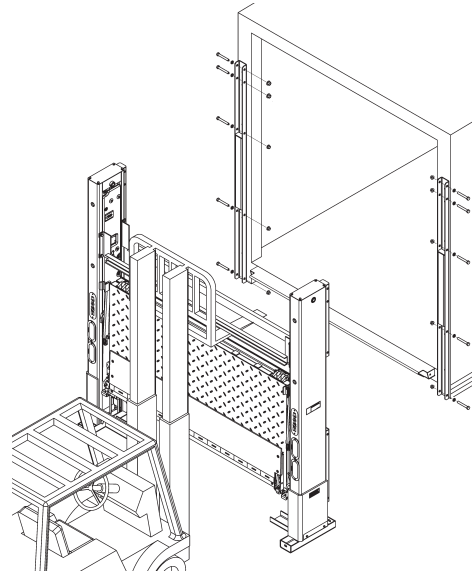

**FIG. 15-1**

**Method 2** - Liftgate equipped with column mounting brackets can be used as an installation jig for the mounting brackets and extension plate to vehicle body (**FIG. 15-2**). Liftgate can be unbolted from vehicle body and bolted on vehicle body. Refer to the **WELD LIFTGATE TO BODY** instructions in **STEP 3**.

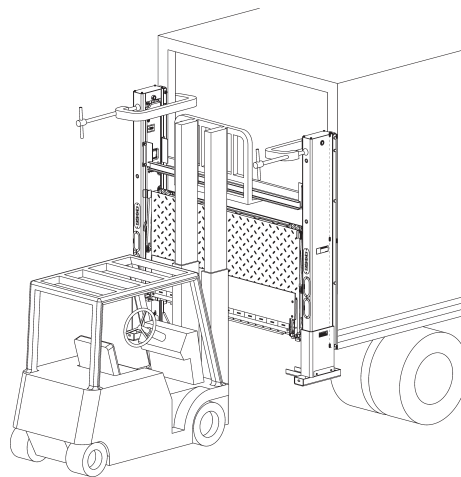

**FIG. 15-2**

# STEP 3 - POSITION LIFTGATE PRE-INSTALL MOUNTING BRACKETS AND EXTENSION PLATE

## CAUTION

Some mild steel Liftgate mounting channels and extension plates are coated with a protective film and shipped unpainted. The film, if not removed for painting, can cause paint to separate from surface. Use hot soapy water and rinse water to remove the protective film before painting.

**NOTE:** Before installing the mounting channels and extension plate, use hot soapy water and rinse water to remove the protective film from these parts.

## ⚠ WARNING

Recommended practices for welding on steel parts are contained in the current AWS (American Welding Society) D1.1 Structural Welding Code - Steel. Damage to Liftgate and/or vehicle, and personal injury can result from welds that are done incorrectly.

- Center the extension plate on rear of vehicle body and flush with top of the rear sill. Then, weld as shown in **FIGS. 16-1 and 16-2.**

START AT CENTER.  
BOTH ENDS MUST BE  
WELDED.

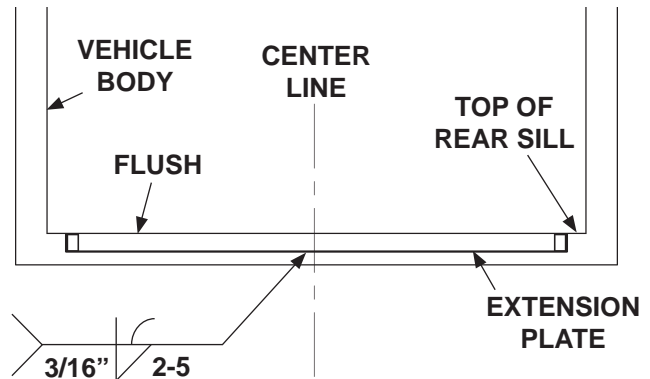

**CENTERING EXTENSION PLATE  
ON 96" WIDE VEHICLE BODY  
FIG. 16-1**

START AT CENTER.  
BOTH ENDS MUST BE  
WELDED.

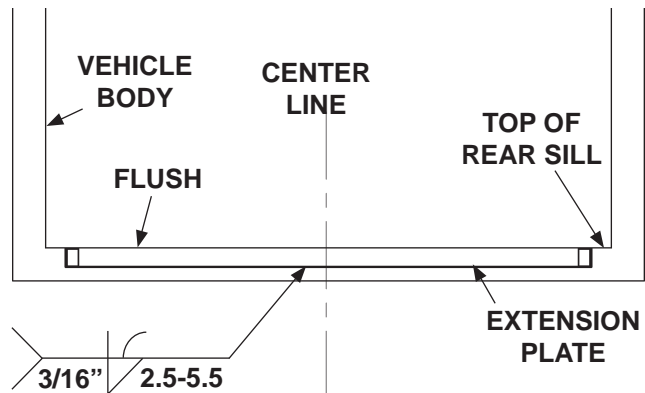

**CENTERING EXTENSION PLATE  
ON 102" WIDE VEHICLE BODY  
FIG. 16-2**

## STEP 3 - POSITION LIFTGATE - Continued

### PRE-INSTALL MOUNTING BRACKETS AND EXTENSION PLATE - Continued

**NOTE:** Distance between extension plate and RH mounting bracket is measured from the inside wall of mounting bracket as shown in illustration.

2. Position RH mounting bracket as shown in **FIGS. 17-1A and 17-1B**. Then, weld RH mounting bracket to vehicle.

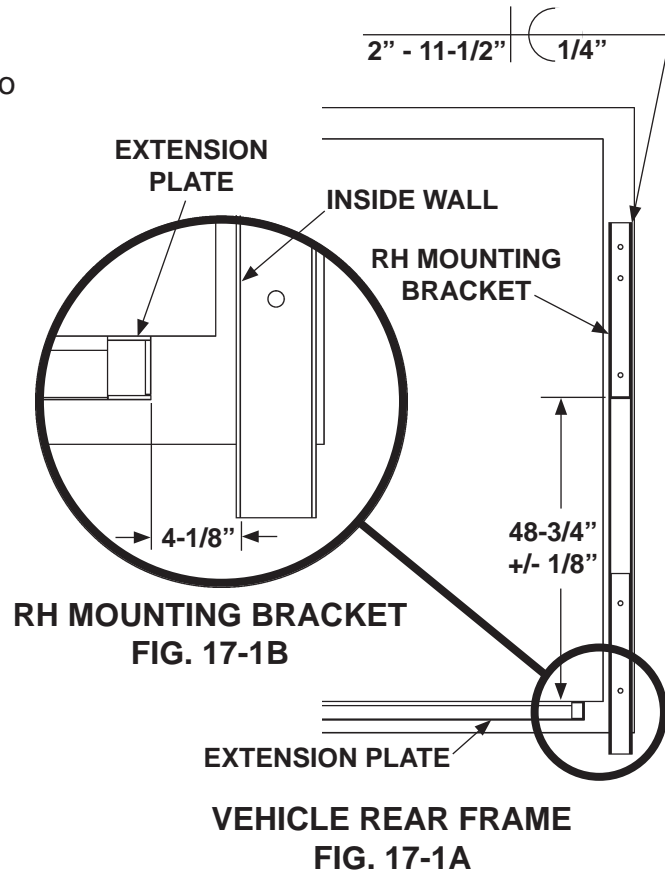

## STEP 3 - POSITION LIFTGATE - Continued

### PRE-INSTALL MOUNTING BRACKETS AND EXTENSION PLATE - Continued

**NOTE:** Distance between LH & RH mounting brackets is measured from the inside wall of each bracket as shown in the illustrations below.

3. Position LH mounting bracket on vehicle body as shown in **FIGS. 18-1A, 18-1B, and 18-1C**. Then, weld LH mounting bracket to vehicle body (**FIGS. 18-1A and 18-1B**).

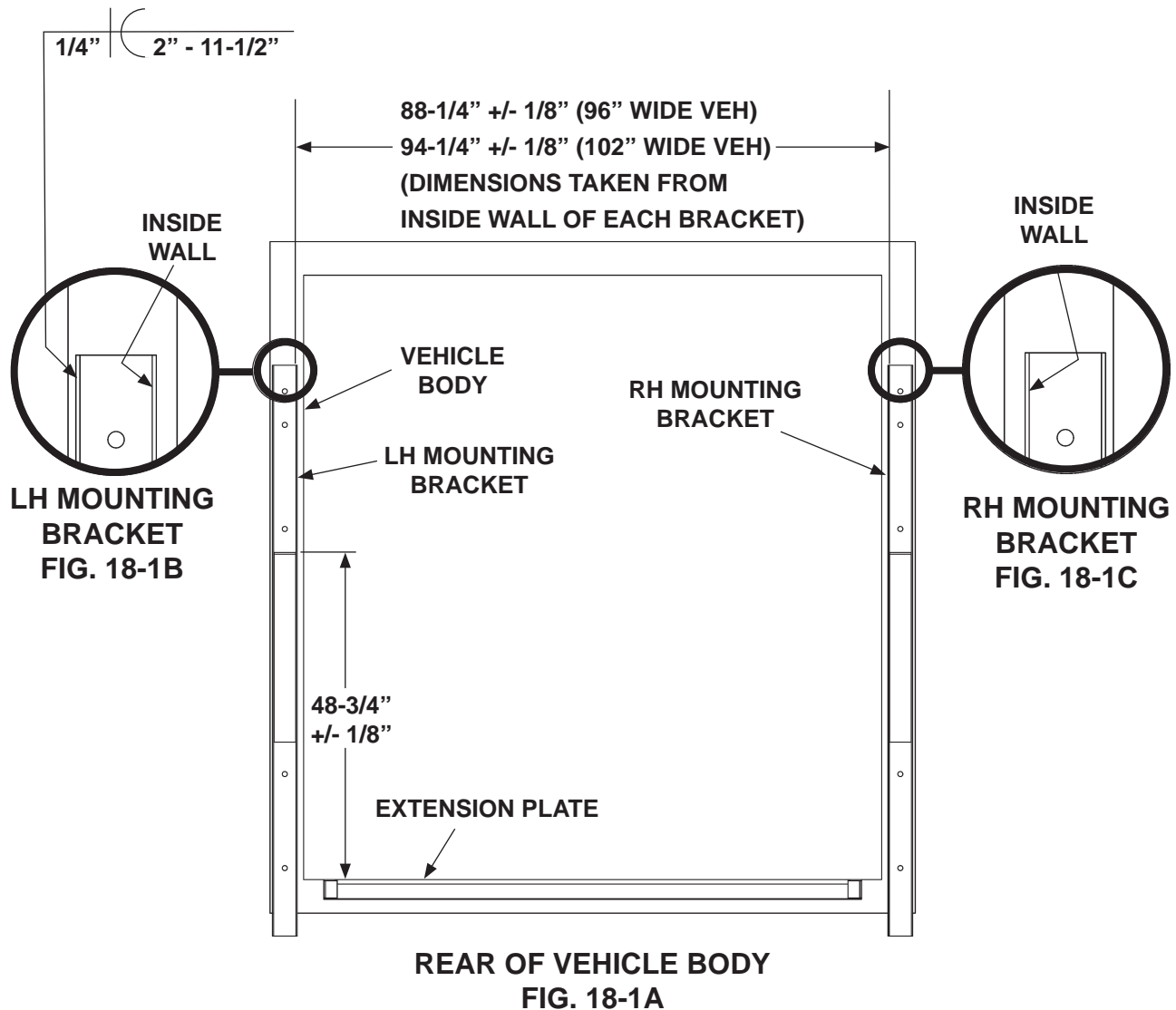

MAXON® 11921 Slauson Ave. Santa Fe Springs, CA. 90670 (800) 227-4116 FAX (888) 771-7713

## STEP 3 - POSITION LIFTGATE - Continued

### PRE-INSTALL MOUNTING BRACKETS AND EXTENSION PLATE - Continued

4. Weld the control box bracket to the vehicle body on the curbside of vehicle as shown in **FIG. 19-1**.

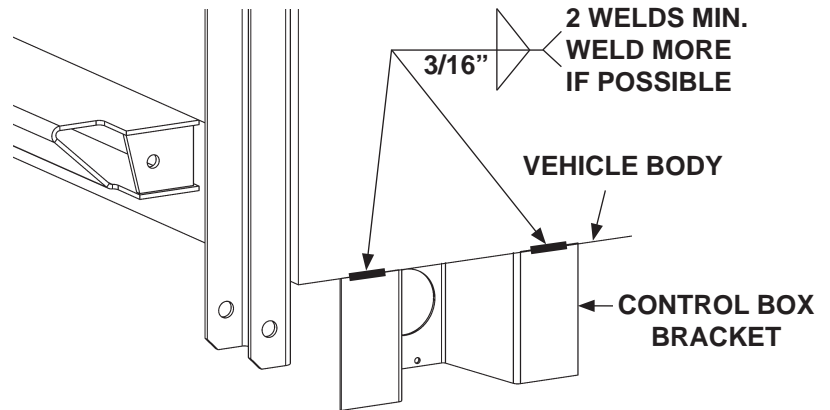

**WELDING CONTROL SWITCH  
BRACKET TO VEHICLE BODY  
FIG. 19-1**

## STEP 3 - POSITION LIFTGATE - Continued WELD LIFTGATE TO BODY

1. Bolt mounting brackets and extension plate to both columns (FIG. 20-1). For this step, torque channel bolts and lock nuts to no more than **60 lb-ft** for stainless steel brackets and **100 lb-ft** for standard steel brackets (FIG. 20-1). Then finger tighten 1/2"-13 extension plate bolts and lock nuts (FIG. 20-1).

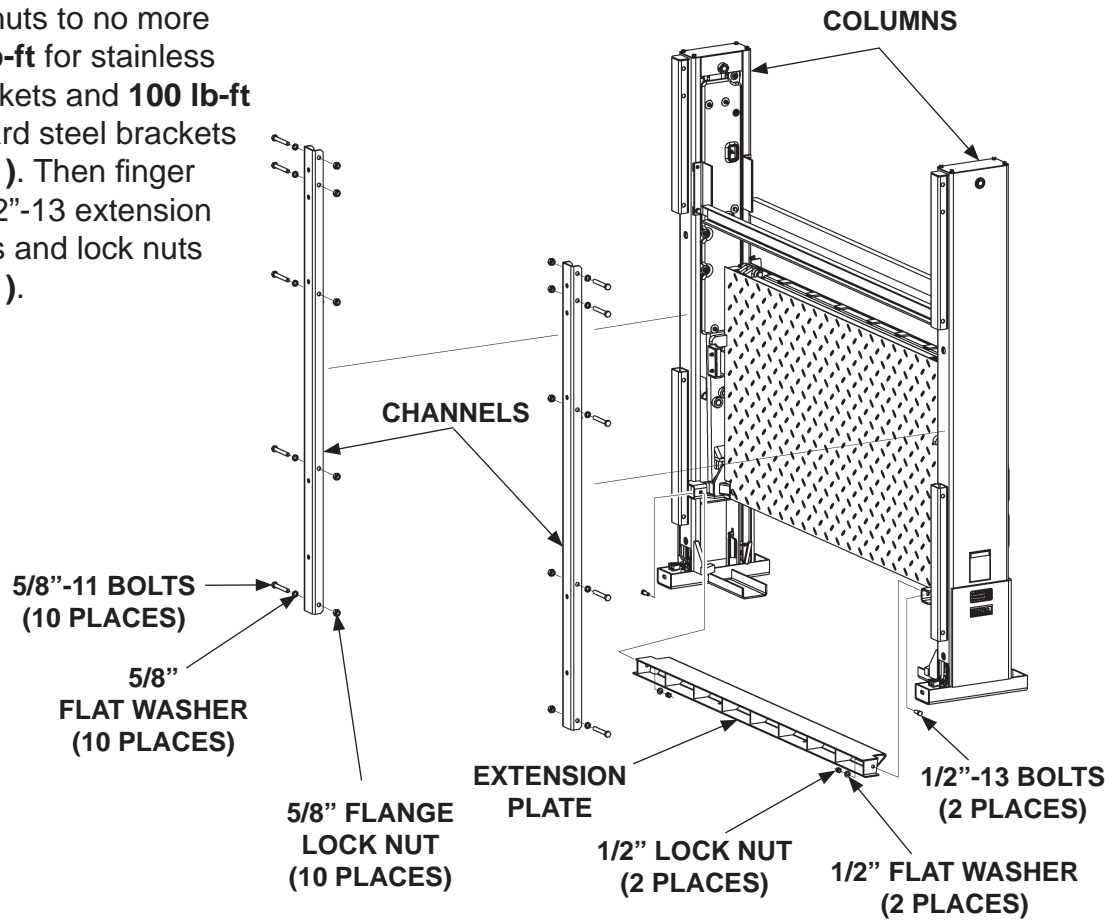

**BOLTING MOUNTING BRACKETS &  
EXTENSION PLATE  
FIG. 20-1**



## STEP 3 - POSITION LIFTGATE - Continued

### WELD LIFTGATE TO BODY

2. Measure distance between outboard side of columns as shown in **FIG. 21-1**. If distance is less than 95.94" or 101.94", add spacers according to instructions below.

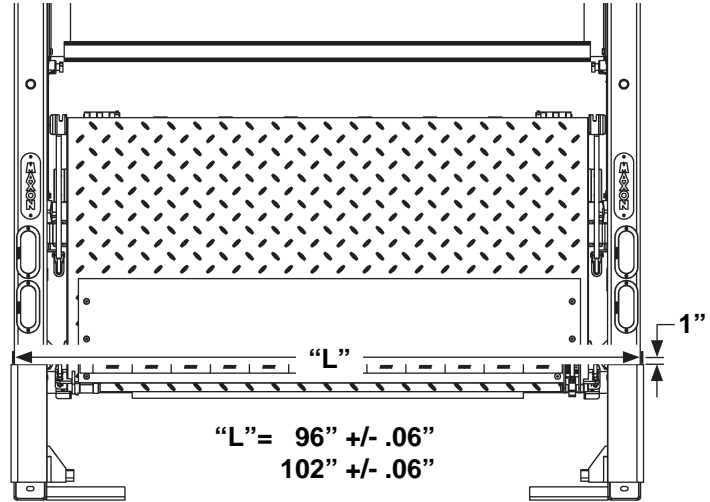

**MEASURING OUTBOARD WIDTH**  
**FIG. 21-1**

**NOTE:** Installation kit contains quantity of four .030" spacers for repositioning columns to 96" or 102" width outboard.

3. Add spacer(s) between extension plate and mounting bracket as follows to reposition columns to minimum 95.94" or 101.94" outboard width (**FIG. 21-1**). Unbolt one end of extension plate. Next, bolt from 1 to 4 spacers as required, between extension plate and mounting bracket (**FIG. 21-2**). Repeat column measurement (2). Add or remove spacers to get the 96"  $\pm$ .06" or the 102"  $\pm$ .06" outboard width. When width is correct, torque 1/2"-13 extension plate nuts and bolts to **85 lb-ft** (**FIG. 21-1**).

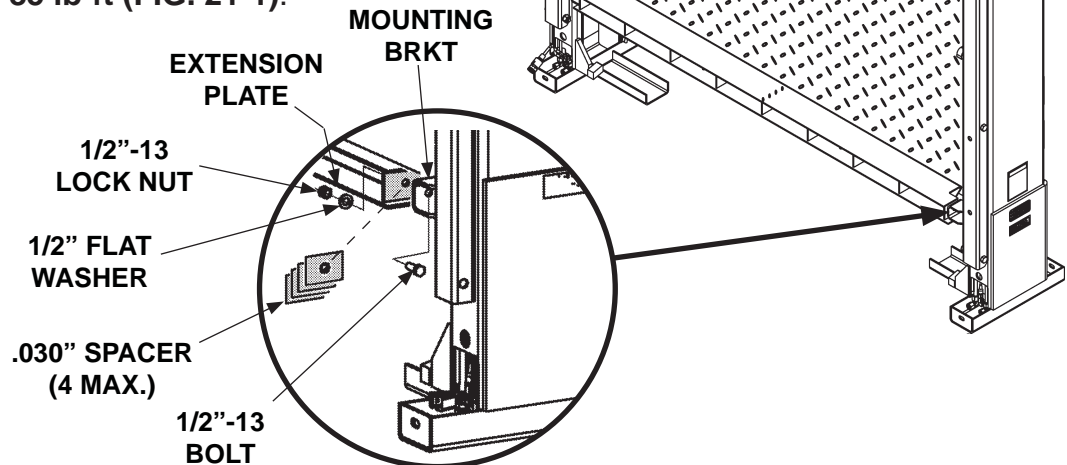

**FIG. 21-2**

11921 Slauson Ave. Santa Fe Springs, CA. 90670 (800) 227-4116 FAX (888) 771-7713  
**MAXON**

## STEP 3 - POSITION LIFTGATE - Continued

### WELD LIFTGATE TO BODY - Continued

### ⚠ WARNING

Recommended practices for welding on steel parts are contained in the current AWS (American Welding Society) D1.1 Structural Welding Code - Steel. Damage to Liftgate and/or vehicle, and personal injury can result from welds that are done incorrectly.

**NOTE:** With the following instructions, the column mounting brackets can be positioned on the vehicle body using the Liftgate as a positioning fixture.

**NOTE:** Before welding extension plate to vehicle body, make sure:

- Inboard edge of extension plate is flush with the top of sill on vehicle body.
- Top surface of extension plate is level with the ground.

### CAUTION

Comply with welding CAUTION decals on the LH & RH runners.

### CAUTION

Electrical components and metal parts on this liftgate can be severely damaged by connecting an electric welder to liftgate at the wrong place. To prevent damage, always connect ground lead directly to the component being welded (e.g. runner, column, platform) and as close to the weld as possible.

P/N 260293

### CAUTION

To protect the original paint system, a 3" wide area of paint must be removed from all sides of the weld area before welding.

4. Weld 2 pieces of 10" x 2" angle stock to the top surface of the extension plate near the LH column as shown in FIGS. 22-1A and 22-1B. Repeat for RH column. The angle stock helps keep extension plate flush with top of vehicle bed while installing Liftgate.

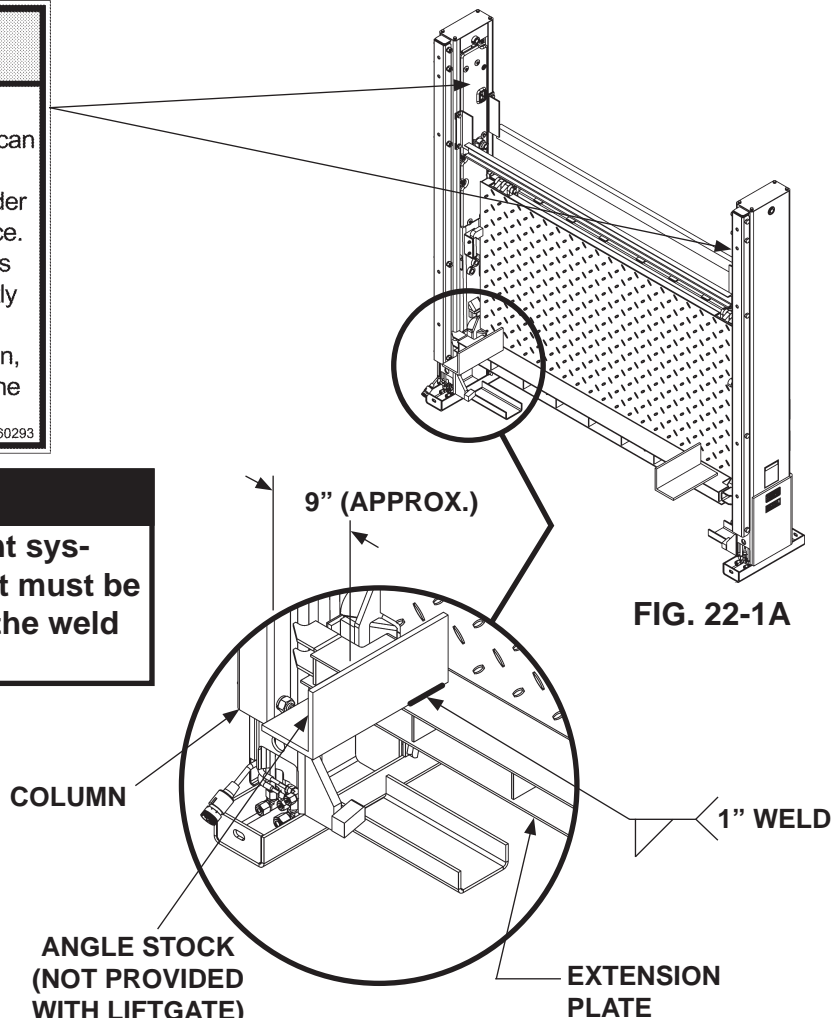

**FIG. 22-1B**

**FIG. 22-1A**

## STEP 3 - POSITION LIFTGATE - Continued

### WELD LIFTGATE TO BODY - Continued

**NOTE:** Weld mounting brackets to vehicle body (columns equipped with mounting brackets only).

5. Use overhead hoist or forklift to center Liftgate against the vehicle (**FIG. 23-1**). Let angle stock, welded to extension plate, rest on the top surface of the vehicle bed.
6. Clamp top of each column to vehicle body to prevent gap (**FIG. 23-1**).

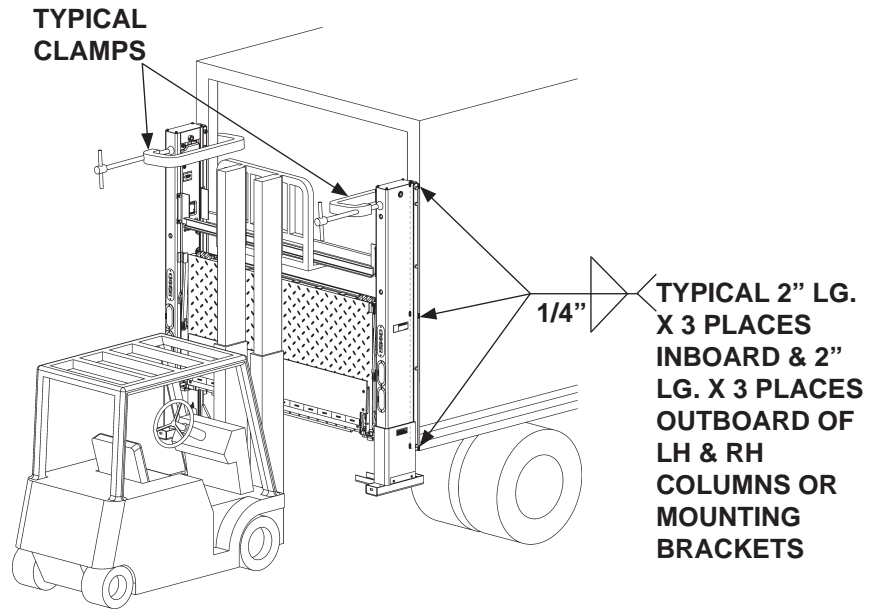

**MOUNTING BRACKET  
OPTION SHOWN  
FIG. 23-1**

### CAUTION

To protect the original paint system, a 3" wide area of paint must be removed from all sides of the weld area before welding.

7. Weld the RH and LH columns or mounting brackets to vehicle body as shown in **FIG. 23-1**.

## STEP 4 - BOLT LIFTGATE TO VEHICLE (PRE-INSTALLED CHANNELS & EXTENSION PLATE)

**NOTE:** Refer to **INSTALLED LIFTGATE** in the **VEHICLE REQUIREMENTS** section of this manual.

1. Use overhead hoist or forklift to position Lift-gate on vehicle body. Line up the bracket on the RH column with the RH mounting bracket on the vehicle body (**FIG. 24-1**).
  
2. Make sure brackets, on LH column and LH side of vehicle body, are lined up (**FIG. 24-1**).

**CAUTION**

Ensure flange lock nuts are tight enough for flange to bottom against column brackets. Do not overtighten. Once installed, re-tightening is not required. If removed, replace the lock nuts with new flange lock nuts from MAXON. Never reuse the old nuts.

3. Mate the brackets on RH and LH sides of vehicle body. Next, bolt RH brackets together with the bolts, flat washers, and flange lock nuts (kit items) (**FIG. 24-1**). Bolt the LH brackets together. For this step, torque channel bolts and lock nuts to **100 lb-ft** for stainless steel brackets and **125 lb-ft** for standard steel brackets (**FIG. 24-1**).

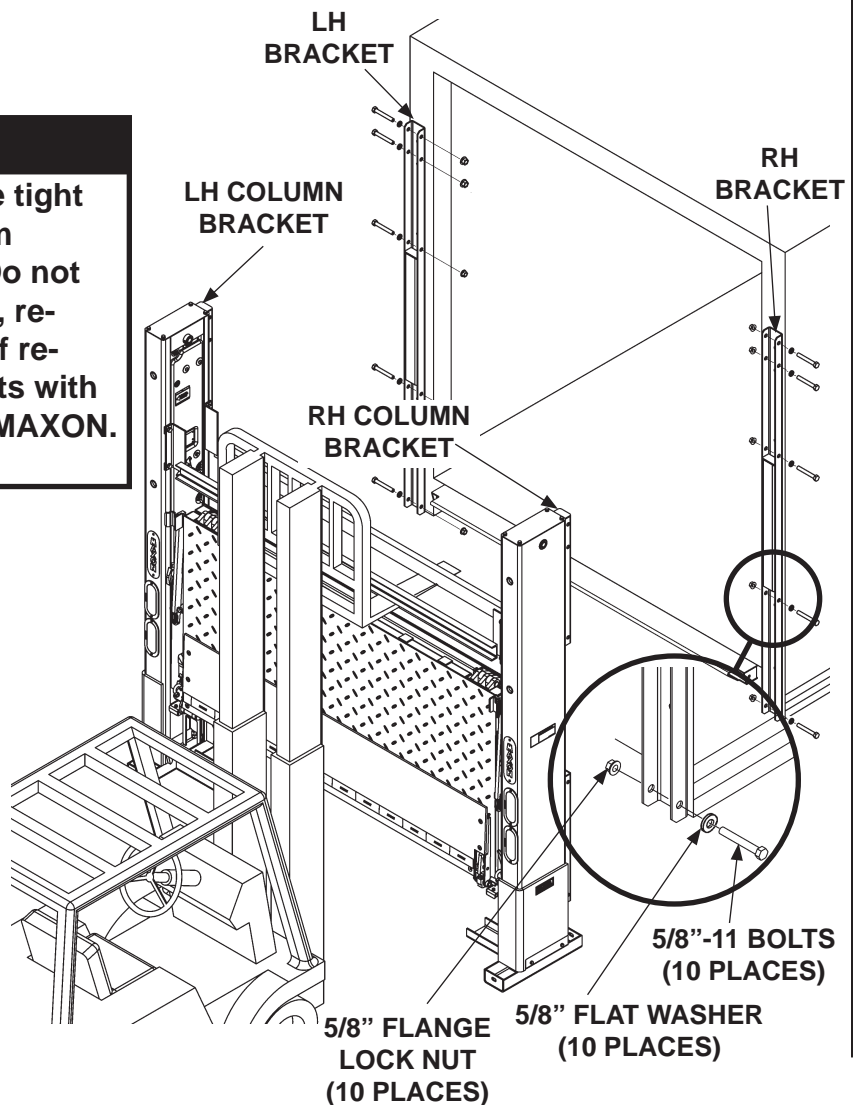
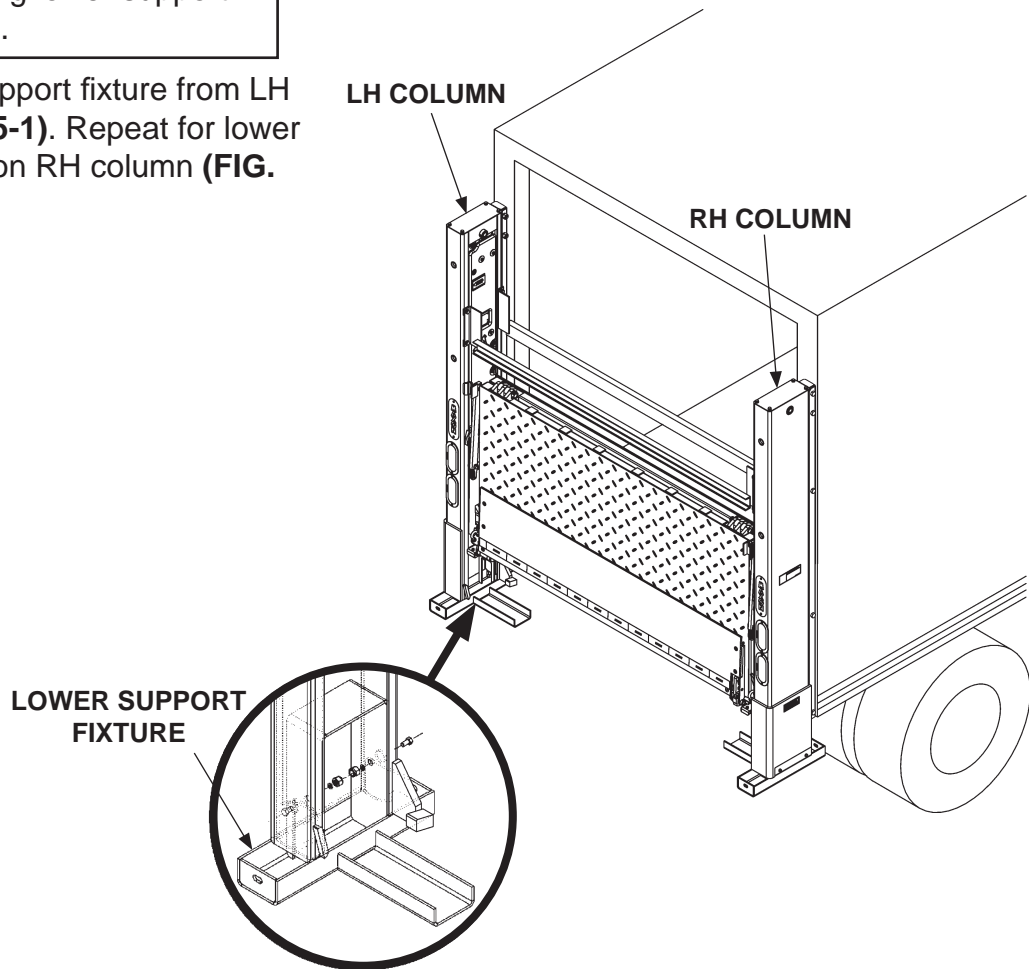

**FIG. 24-1**

## STEP 5 - REMOVE LOWER SUPPORT FIXTURES

**NOTE:** Use short wrenches for unbolting lower support fixtures.

Unbolt lower support fixture from LH column (**FIG. 25-1**). Repeat for lower support fixture on RH column (**FIG. 25-1**).



**UNBOLTING LOWER SUPPORT FIXTURE  
FIG. 25-1**

## STEP 6 - POSITION PUMP BOX FRAME

**NOTE:** Make sure pump box is closer to Liftgate than battery box (if installed) and pump box cover opens toward curb-side of vehicle. Also, make sure hydraulic hoses are installed without straining hoses. Distance from pump box to Liftgate is limited by lengths of hydraulic hoses and wiring harness supplied with Liftgate.

Position pump box frame (or optional battery box) on the ground where it will be welded to vehicle body in the next step. Make sure pump box (and battery box if supplied) are securely bolted to the frame. Typical installations are shown in **FIGS. 26-1, 26-2, 26-3, 27-1, 27-2 and 27-3.**

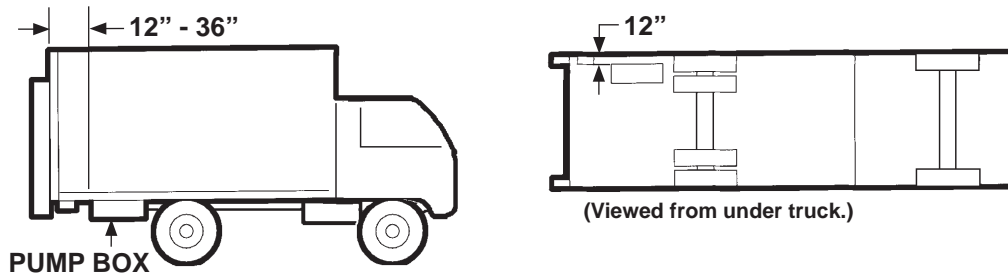

TYPICAL 3 FT. INSTALLATION  
FIG. 26-1

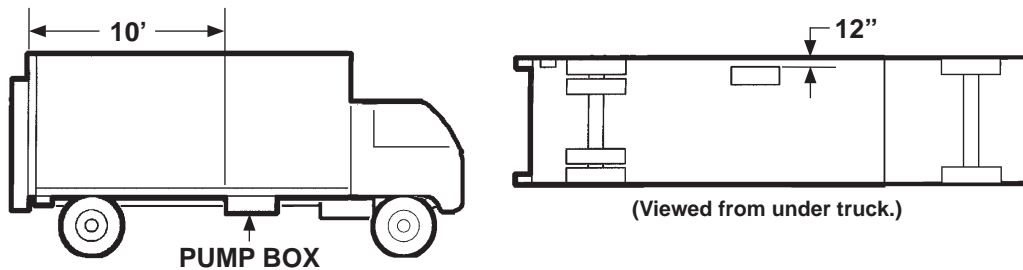

TYPICAL 10 FT. INSTALLATION  
FIG. 26-2

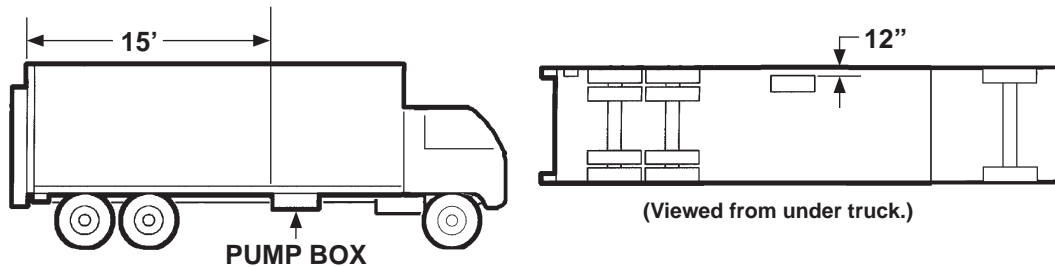

TYPICAL 15 FT. INSTALLATION  
FIG. 26-3



# STEP 6 - POSITION PUMP BOX FRAME - Continued

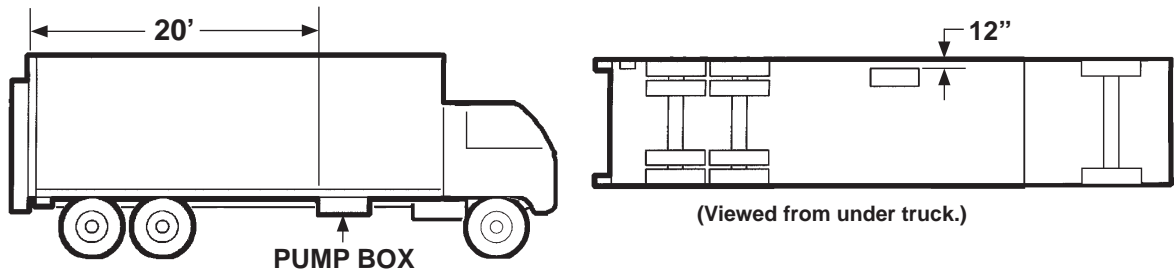

TYPICAL 20 FT. INSTALLATION  
FIG. 27-1

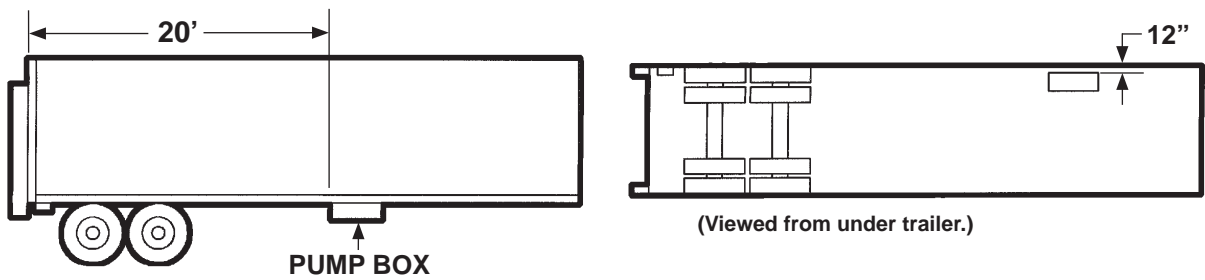

TYPICAL 20 FT. INSTALLATION  
FIG. 27-2

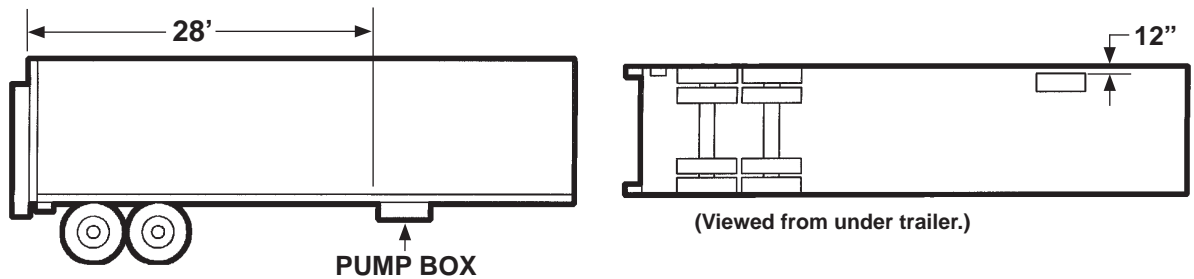

TYPICAL 28 FT. INSTALLATION  
FIG. 27-3

## STEP 7 - ATTACH PUMP & BATTERY BOX FRAME TO VEHICLE

1. Use floor jack or equivalent lifting device to place pump and battery box frame in position on vehicle body cross members as shown in **FIG. 28-1**.

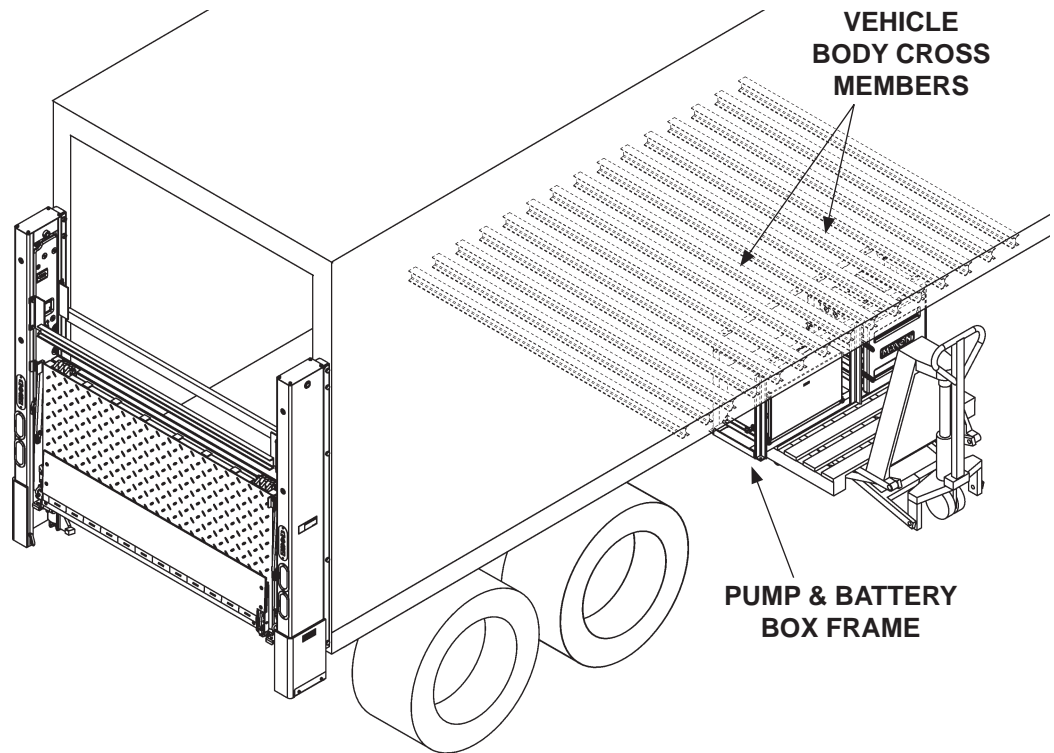

TRAILER WITH PUMP & BATTERY BOX FRAME  
FIG. 28-1

# STEP 7 - ATTACH PUMP & BATTERY BOX FRAME TO VEHICLE - Continued

2. Select holes on top of battery box frame to align mounting brackets flush to cross members. Refer to **FIGS. 29-1A & 29-1B** for trailers and **FIG. 29-2** for trucks. Bolt mounting brackets to battery box frame as shown in **FIG. 29-1C**. Torque each bolt and lock nut to **85-128 lb-ft**.

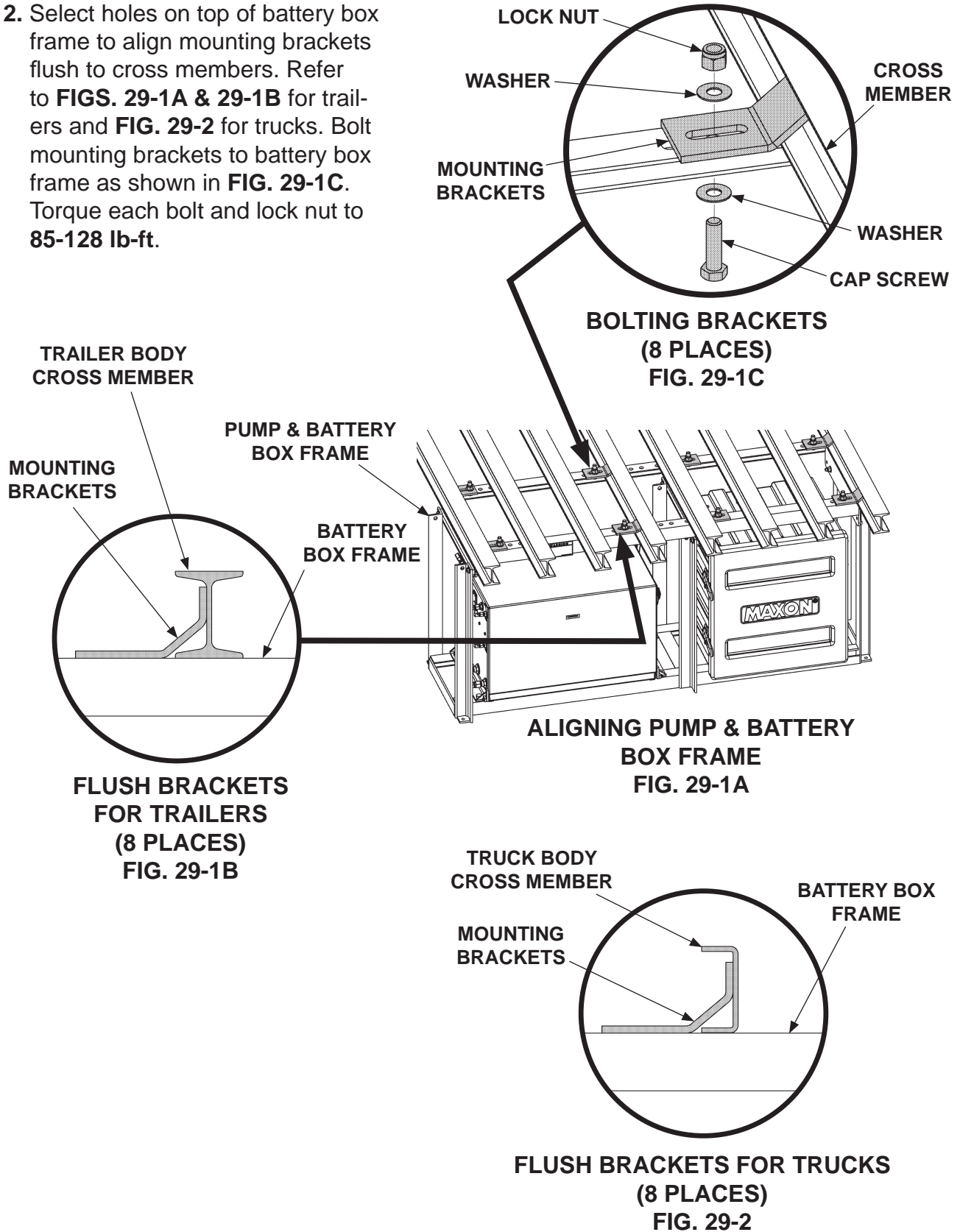

11921 Slauson Ave. Santa Fe Springs, CA. 90670 (800) 227-4116 FAX (888) 771-7713

**MAXON**

# STEP 7 - ATTACH PUMP & BATTERY BOX FRAME TO VEHICLE - Continued

**NOTE:** If welding mounting brackets to cross members, skip instruction 3.

- Using mounting brackets as a template mark and drill holes through cross members (**FIG. 30-1**). Bolt mounting brackets to cross members as shown in **FIGS. 30-2A** and **30-2B**. Torque bolts and lock nuts to **85-128 lb-ft.**

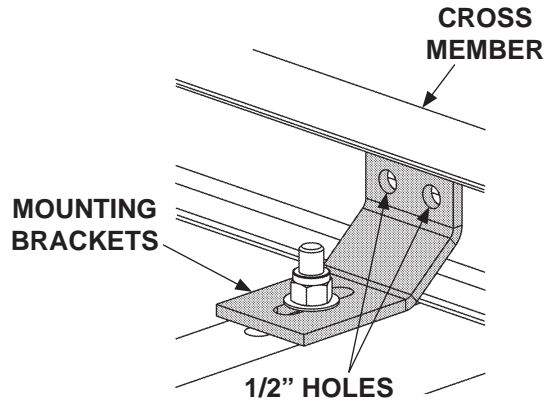

**MARK AND DRILL  
FIG. 30-1**

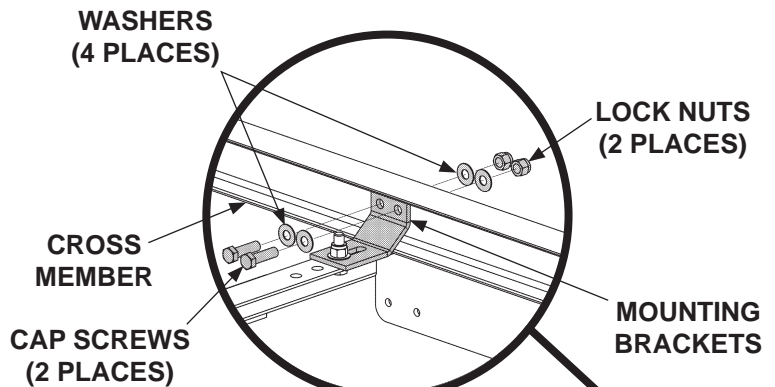

**BOLTING BRACKETS  
(8 PLACES)  
FIG. 30-2B**

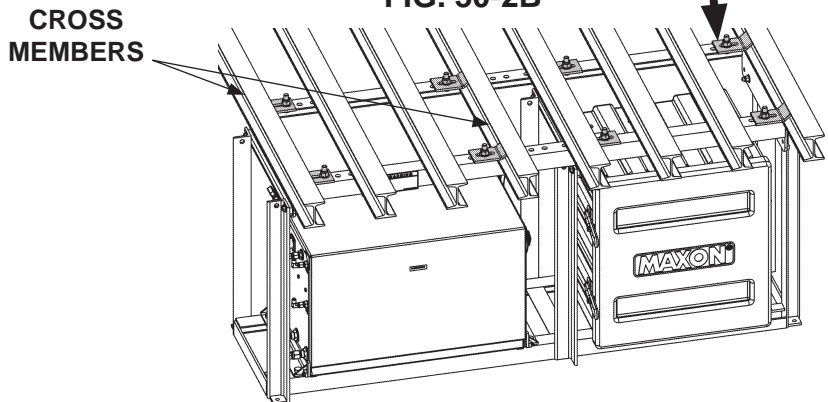

**BOLTING PUMP & BATTERY  
BOX FRAME  
FIG. 30-2A**

# STEP 7 - ATTACH PUMP & BATTERY BOX FRAME TO VEHICLE - Continued

## ⚠ WARNING

Recommended practices for welding on steel parts are contained in the current AWS (American Welding Society) D1.1 Structural Welding Code - Steel. Damage to Liftgate and/or vehicle, and personal injury can result from welds that are done incorrectly.

## CAUTION

To prevent pump box components from being damaged by electric current from welding, connect welder grounding cable to the part being welded.

## CAUTION

Cover pump box and optional battery box with flame-resistant covering before welding pump box frame to vehicle.

4. Weld each bracket to cross members as shown in **FIGS. 31-1A and 31-1B**. Weld top of bracket if accessible.

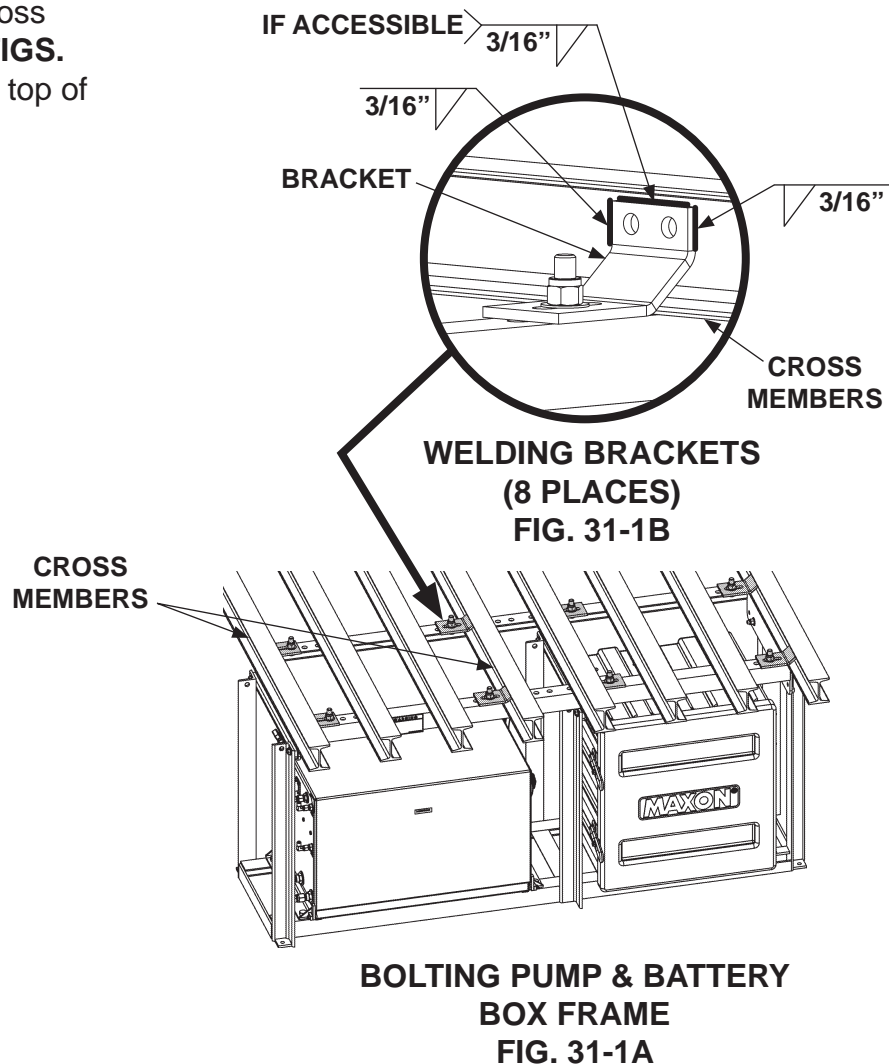

## STEP 7 - ATTACH PUMP & BATTERY BOX FRAME TO VEHICLE - Continued

### ⚠ WARNING

Explosive hydrogen gas from charging batteries can accumulate in battery box if not vented from the box. To prevent hydrogen gas from accumulating, ensure the 3 ventilation holes in battery box are not plugged or covered.

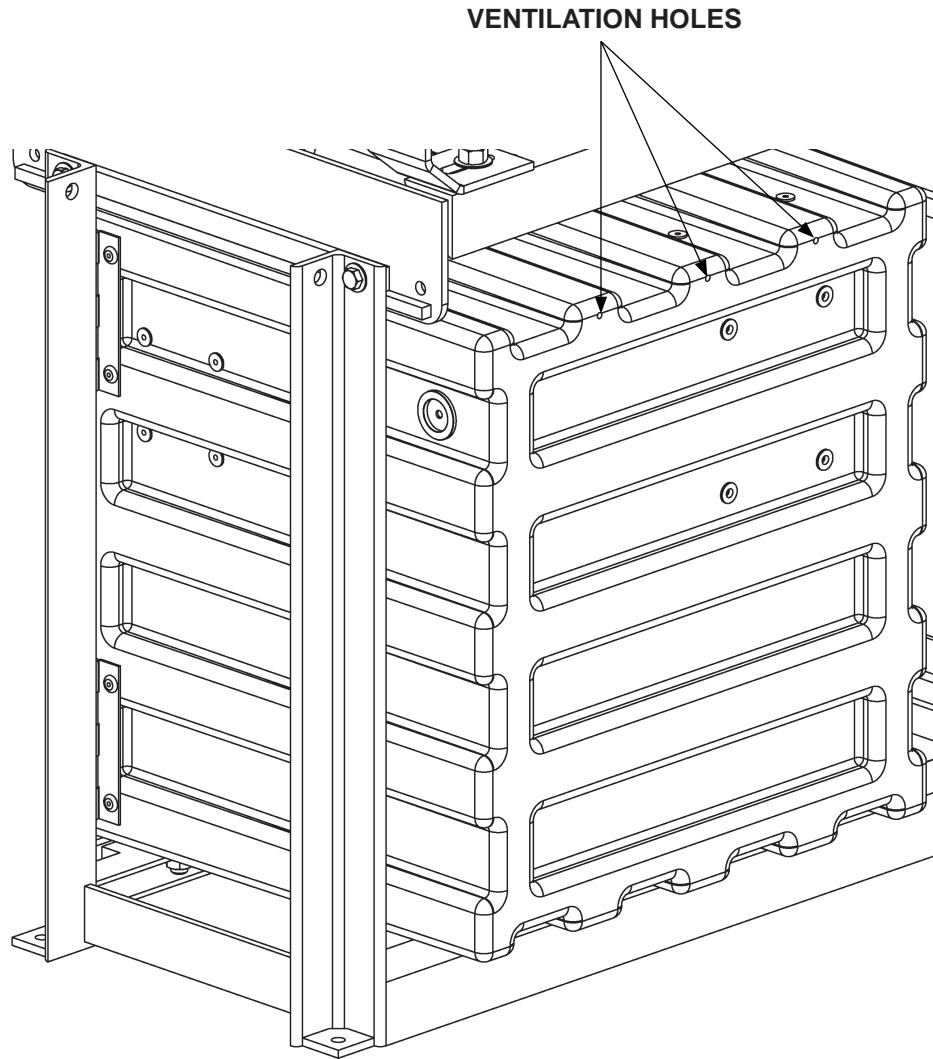

**BATTERY BOX ASSEMBLY  
(REAR VIEW SHOWN)  
FIG. 32-1**

## STEP 8 - RUN HYDRAULIC LINES & ELECTRIC CABLES

### CAUTION

Always route hydraulic hoses and electrical wiring clear of moving parts, brake lines, sharp edges and exhaust systems. Avoid making sharp bends in hoses and wiring. Make sure that bends in the electrical wiring are 1" or more away from electrical connector. Attach securely. If drilling is necessary, first check behind the drilling surface so you do not damage any fuel lines, vent lines, brake lines or wires.

**NOTE:** The hydraulic cylinders in the Liftgate are filled with hydraulic fluid and bled at the factory. To keep air out of the hydraulic system, follow instructions carefully for installing hydraulic system components.

1. Get hydraulic hoses, hydraulic tee, channel guard (if required) and plastic ties from part box and pump box installation kit. Run hydraulic hoses from LH and RH columns to pump box. Connect hydraulic hoses as shown in **FIG. 34-1** and **TABLE 35-1**.
2. Get molded interconnecting harness and molded extension cable from pump box installation kit. Run the molded interconnecting harness and molded extension cable from LH and RH columns to pump box as shown in **FIG. 34-1**.
3. If channel guard is required, bolt up one side of the channel (**FIGS. 34-1 and 35-1**) to vehicle body. Leave bolts loose until all hydraulic hoses (**FIG. 34-1**) and wiring harness (**FIG. 34-1**) are run through channel. After hoses and wiring harness are run, bolt up second side of channel and tighten all bolts and nuts. Use plastic ties to secure runs of hydraulic hoses and wiring harness that are outside of channel guard.



# STEP 8 - RUN HYDRAULIC LINES & ELECTRIC CABLES

## - Continued

### RUN HYDRAULIC LINES

**NOTE:** See TABLE 35-1 for information on the numbered hoses in this illustration.

**CAUTION**  
Before connecting hoses, ensure face seal o-rings are in place.

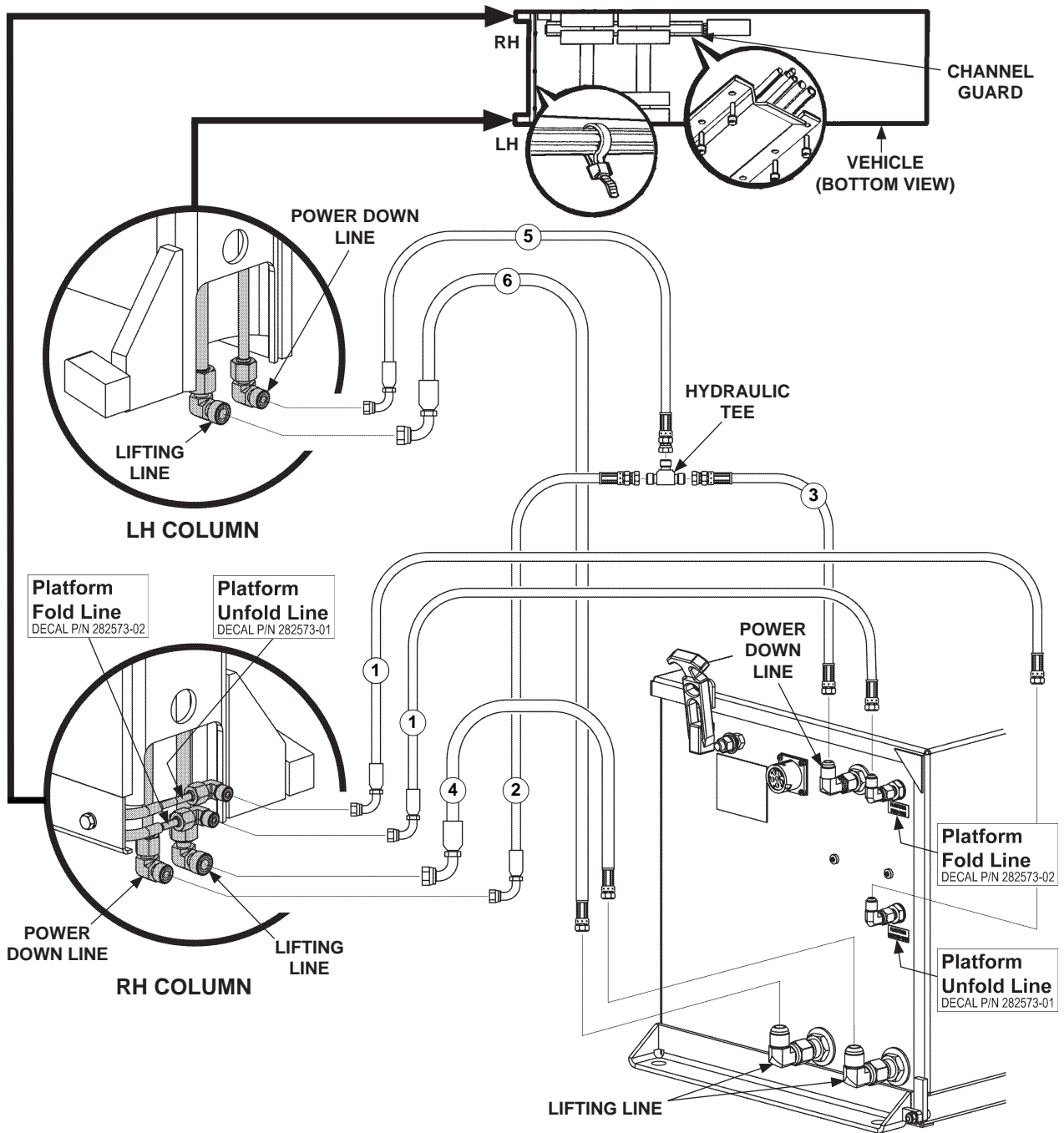

FIG. 34-1

11921 Slauson Ave. Santa Fe Springs, CA. 90670 (800) 227-4116 FAX (888) 771-7713

**MAXON**

**STEP 8 - RUN HYDRAULIC LINES & ELECTRIC CABLES**  
**- Continued**  
**RUN HYDRAULIC LINES**

| <b>PUMP BOX INSTALLATION: REQUIRED HOSES</b> |                   |                   |                   |                   |                   |
|--|-------------------|-------------------|-------------------|-------------------|-------------------|
|  | <b>3 FT.</b>      | <b>10 FT.</b>     | <b>15 FT.</b>     | <b>20 FT.</b>     | <b>28 FT.</b>     |
| <b>1</b>                                     | HP 1/4" X 56" LG  | HP 1/4" X 188" LG | HP 1/4" X 248" LG | HP 1/4" X 308" LG | HP 1/4" X 404" LG |
| <b>2</b>                                     | HP 1/4" X 24" LG  |                   |                   |                   |                   |
| <b>3</b>                                     | HP 1/4" X 34" LG  | HP 1/4" X 166" LG | HP 1/4" X 226" LG | HP 1/4" X 286" LG | HP 1/4" X 382" LG |
| <b>4</b>                                     | HP 3/8" X 64" LG  | HP 3/8" X 196" LG | HP 3/8" X 256" LG | HP 3/8" X 316" LG | HP 3/8" X 412" LG |
| <b>5</b>                                     | HP 1/4" X 100" LG |                   |                   |                   |                   |
| <b>6</b>                                     | HP 3/8" X 142" LG | HP 3/8" X 274" LG | HP 3/8" X 334" LG | HP 3/8" X 394" LG | HP 3/8" X 490" LG |

**TABLE 35-1**

**MAXON**<sup>®</sup> 11921 Slauson Ave. Santa Fe Springs, CA. 90670 (800) 227-4116 FAX (888) 771-7713

# STEP 8 - RUN HYDRAULIC LINES & ELECTRIC CABLES - Continued RUN ELECTRIC CABLES

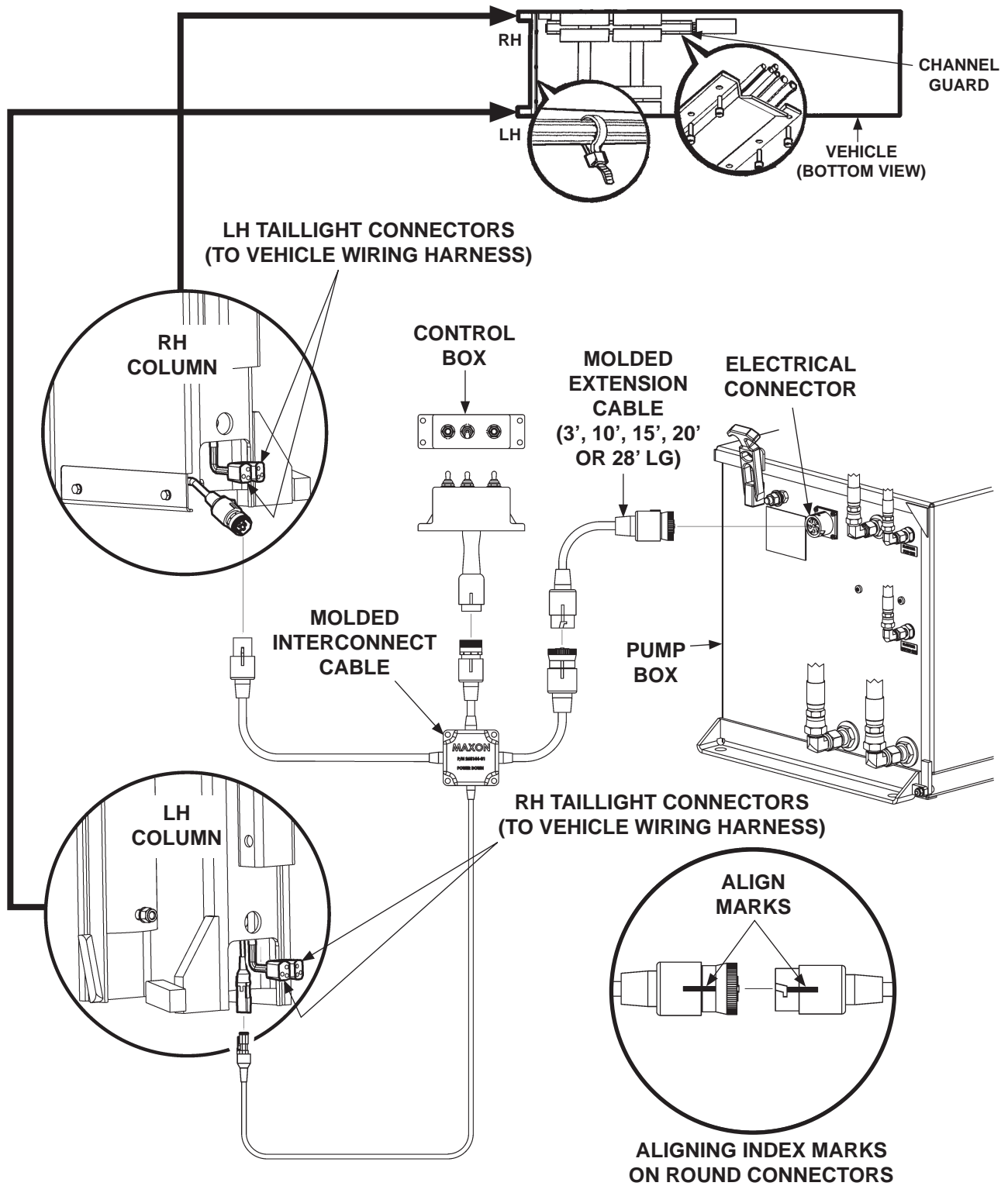

FIG. 36-1

# STEP 9 - CONNECT GROUND CABLE

## GROUNDING TO TRUCK FRAME

**NOTE:** Make sure the Liftgate power unit, all batteries on the vehicle for power unit, and taillights on Liftgate are connected correctly to a common ground.

1. Bolt ground cable to the ground stud on pump box (**FIG. 37-1A**).

**NOTE:** If there is an existing grounding point on truck frame, use it to connect ground cable and skip the step for drilling a hole.

2. Extend the ground cable to reach vehicle frame (**FIG. 37-1C**) without putting tension on cable (after connection). Connect to an existing grounding point if available.
3. If necessary, drill a 11/32" (0.343") hole in vehicle frame for bolting the ground cable terminal lug (**FIG. 37-1C**).

**NOTE:** Clean the ground cable connection point on the frame down to bare metal.

**NOTE:** MAXON recommends using dielectric grease on all electrical connections.

4. Bolt the ground cable terminal lug to vehicle frame as shown in **FIG. 37-1C**.

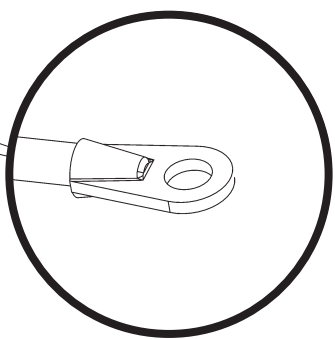
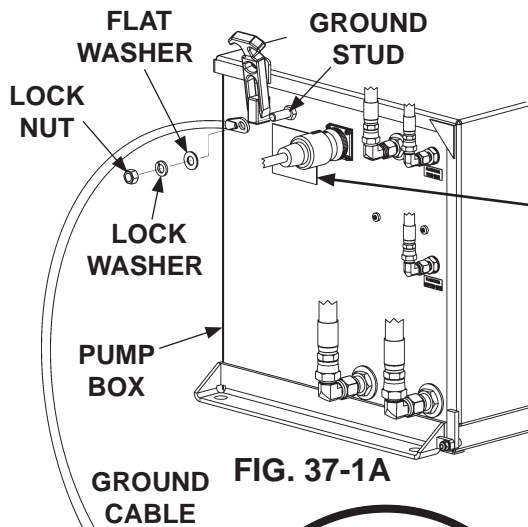

**GROUND STUD**  
 CONNECT GROUND CABLE BEFORE OPERATING LIFTGATE. SEE INSTALLATION MANUAL FOR INSTRUCTIONS.  
 P/N 765734-01

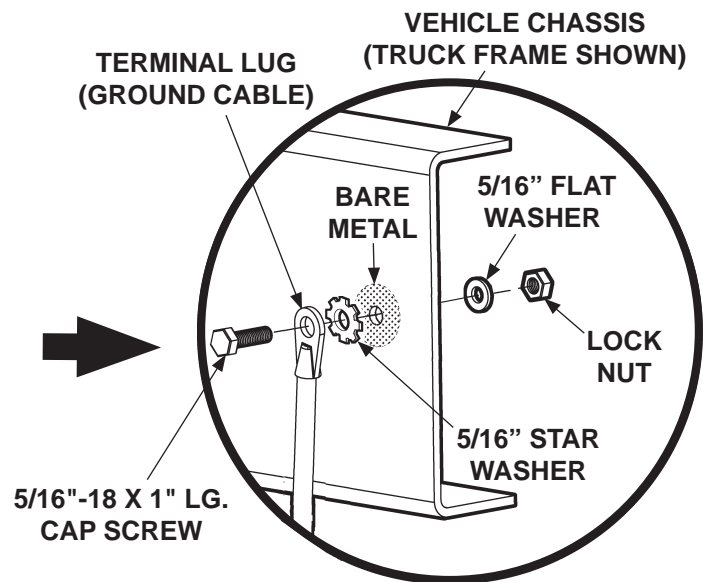

## STEP 9 - CONNECT GROUND CABLE - Continued

### GROUNDING TO BATTERY BOX (IF EQUIPPED)

**NOTE:** Make sure the Liftgate power unit, battery box and batteries, taillights on Liftgate, and vehicle charging system are connected correctly to a common ground. For trailers, if possible, use 2-pole charge line to connect charging system on tractor to the Liftgate batteries.

1. Attach ground cable to ground stud outside the pump box (**FIG. 38-1**). Tighten lock nut.

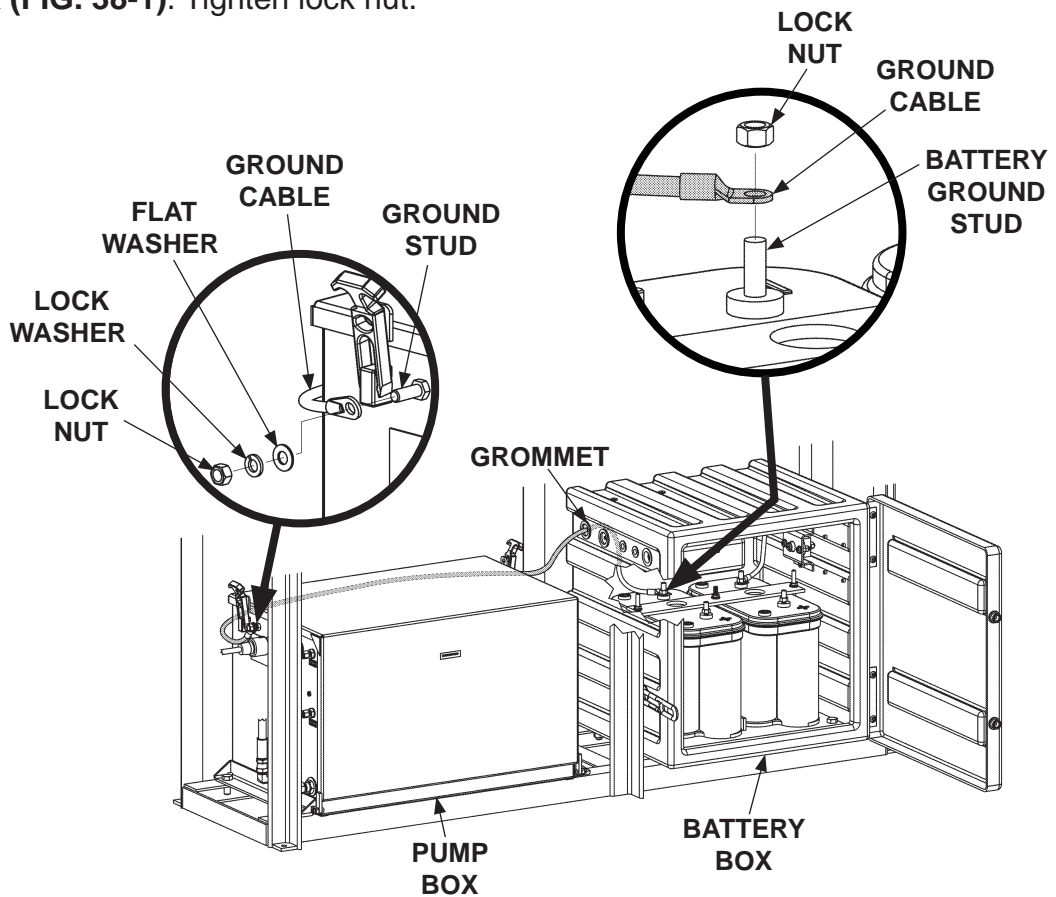

**FIG. 38-1**

2. Route ground cable behind pump box to the grommet on the side wall of battery box (**FIG. 38-1**). Then, pull ground cable through grommet to the battery ground stud (**FIG. 38-1**).

**NOTE:** Ensure battery box is connected by cable to common ground on vehicle.

3. Attach ground cable to battery ground stud (**FIG. 38-1**). Tighten lock nut.

# STEP 10 - INSTALL CONTROL BOX & BRACKET

## ⚠ WARNING

Recommended practices for welding on steel parts are contained in the current AWS (American Welding Society) D1.1 Structural Welding Code - Steel. Damage to Liftgate and/or vehicle, and personal injury can result from welds that are done incorrectly.

## CAUTION

Prevent damage to control box. Make sure installed control box does not protrude out from the side of vehicle body.

## CAUTION

To protect the original paint system, a 3" wide area of paint must be removed from all sides of the weld area before welding.

**NOTE:** If control box bracket is already installed, skip instruction 1.

1. Weld the control box bracket (parts box item) under the vehicle body on the curb-side of vehicle as shown in FIGS. 39-1A and 39-1B.

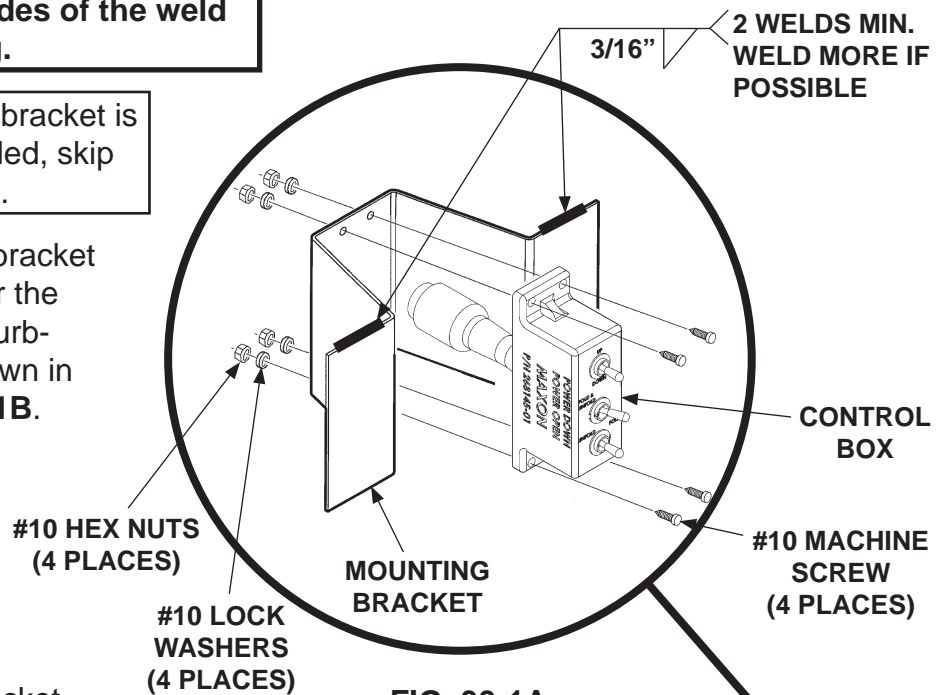

FIG. 39-1A

2. Bolt control box to bracket (FIG. 39-1A).

3. If Liftgate comes with remote hand-held control kit, install hand-held control according to **Instruction Sheet** contained in kit.

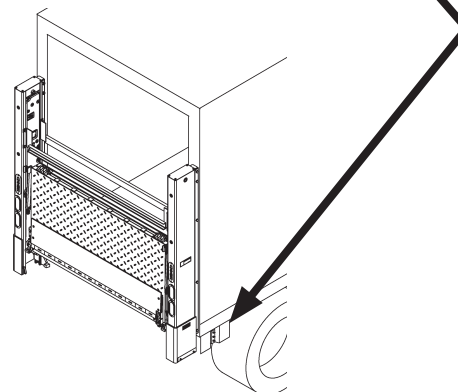

FIG. 39-1B

# STEP 11 - RUN CHARGE LINES

## ⚠ CAUTION

Never route an energized wire. Make sure battery is disconnected. Always route electrical wires clear of moving parts, brake lines, sharp edges and exhaust systems. Avoid making sharp bends in wiring. Attach securely. If drilling is necessary, first check behind the drilling surface so you do not damage any fuel lines, vent lines, brake lines or wires.

**NOTE:** Make sure cable is long enough to reach master disconnect switch on Liftgate pump box (or circuit breaker in optional battery box, if installed) without putting tension on the cable.

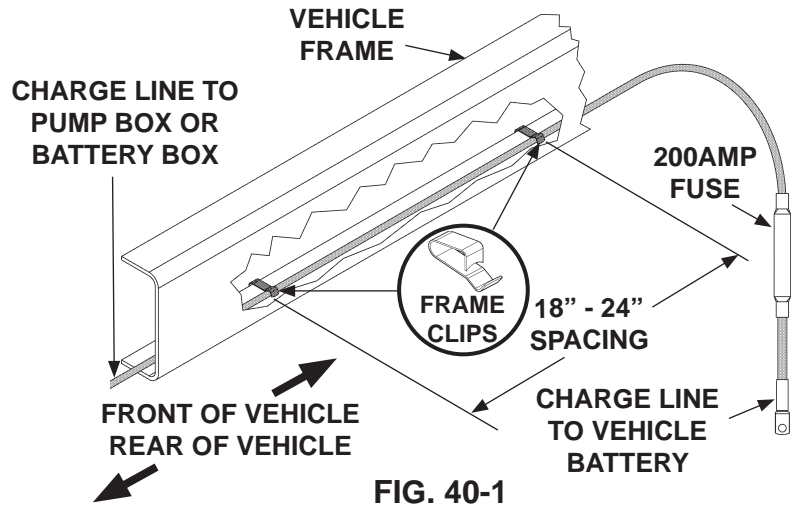

FIG. 40-1

1. Install vehicle charge line by running the line along the inside of vehicle frame (FIG. 40-1). Make sure **200 amp fuse** (FIG. 40-1) end of cable is by the battery. Run the charge line from vehicle battery to Liftgate pump box master disconnect switch (FIG. 40-2) or circuit breaker in an optional battery box (FIG. 40-3), if installed. Use frame clips (parts box item) and plastic ties (as required) from charge line kit to secure cable.

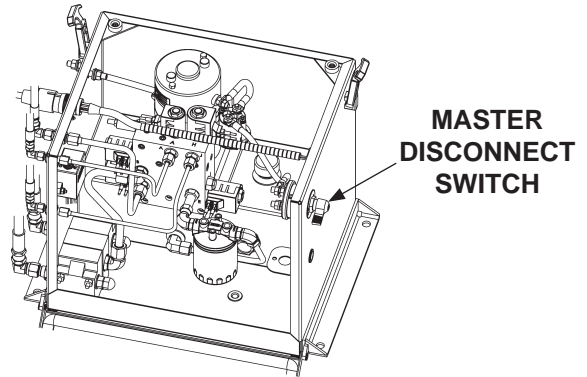

FIG. 40-2

2. If Liftgate comes with:

- Single Pole Tractor Charge Line Kit
- Single Pole Trailer Charge Line Kit
- Dual Pole Tractor Charge Line Kit
- Dual Pole Trailer Charge Line Kit

Install charge line according to **Instruction Sheet** contained in each kit.

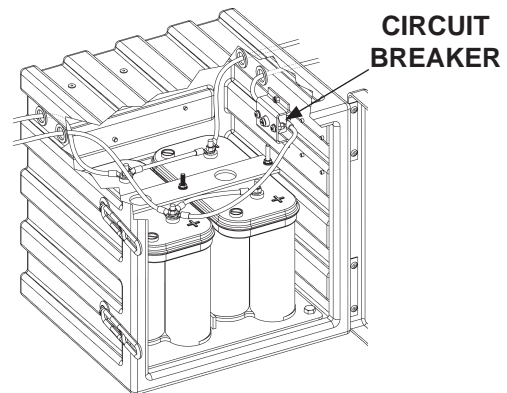

FIG. 40-3



## STEP 12 - CONNECT BATTERIES TO LIFTGATE

### **⚠ WARNING**

To prevent injury and equipment damage, make sure (-) battery cable is disconnected and master disconnect switch is in the OFF position before connecting vehicle charge lines or power cables.

**NOTE:** For recommended 6 volt and 12 volt battery connections, refer to the **RECOMMENDED LIFTGATE POWER CONFIGURATION** section in this manual.

1. Disconnect (-) battery cable (**FIG. 41-1**) from battery.

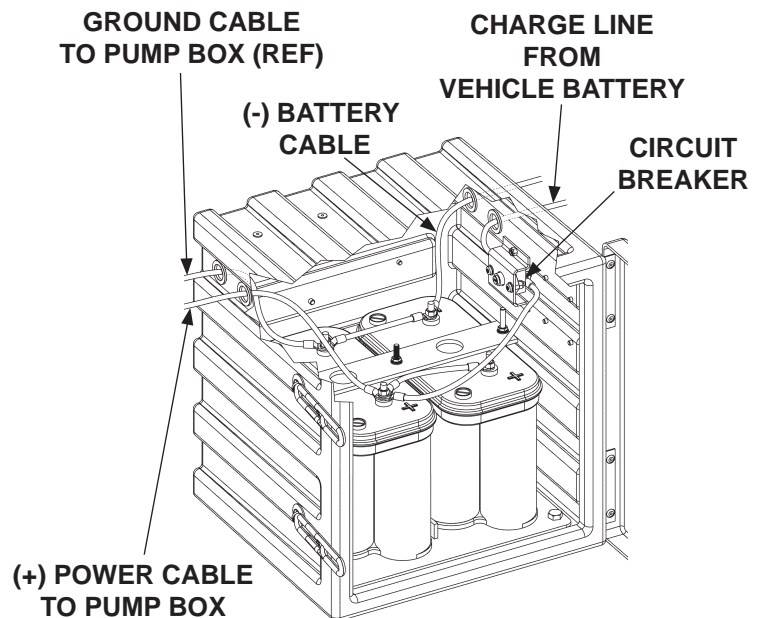

**BATTERY BOX  
FIG. 41-1**

2. Connect vehicle charge line to unconnected terminal on master disconnect switch (**FIG. 41-2**).

**NOTE:** After battery cables are connected, ensure pump box cover and battery box cover (if equipped) are closed.

3. If optional battery box (**FIG. 41-1**) is installed, connect (+) power cable from battery box to master switch in the pump box (**FIG. 41-2**). Then, connect vehicle charge line to circuit breaker in optional battery box (**FIG. 41-1**).

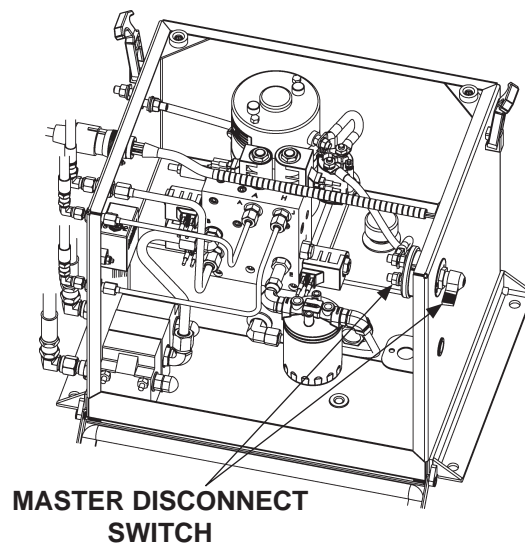

**PUMP BOX  
FIG. 41-2**

## STEP 13 - ADD HYDRAULIC FLUID TO RESERVOIR

### CAUTION

Keep dirt, water and other contaminants from entering the hydraulic system. Before opening the hydraulic fluid reservoir filler cap, drain plug and hydraulic lines, clean up contaminants that can get in the openings. Also, protect the openings from accidental contamination.

1. Open pump box cover (FIG. 42-1).

2. Remove the filler cap (FIG. 42-1).  
Add **4 quarts** (single pump) or **6 quarts** (dual pump) of **Exxon Univas HVI-13** hydraulic fluid to pump reservoir.

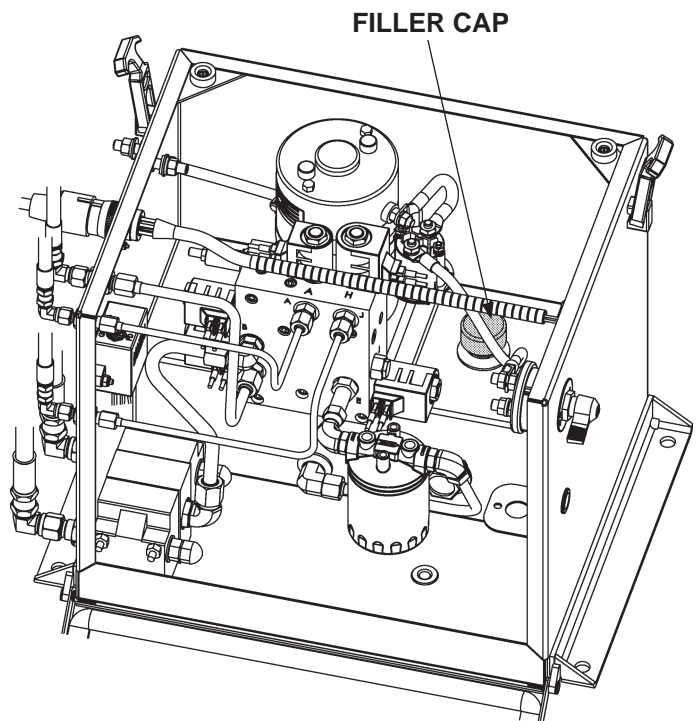

PUMP BOX SHOWN WITH SINGLE PUMP  
FIG. 42-1

3. Reinstall the filler cap (FIG. 42-1).

## STEP 14 - PRESSURIZE HYDRAULIC SYSTEM

### **⚠ WARNING**

To prevent injury and equipment damage, pressurize hydraulic system before removing lower support fixtures and operating Liftgate.

1. To pressurize lifting cylinders, set control box toggle switch to **UP** for 10-15 seconds as shown in **FIG. 43-1**.

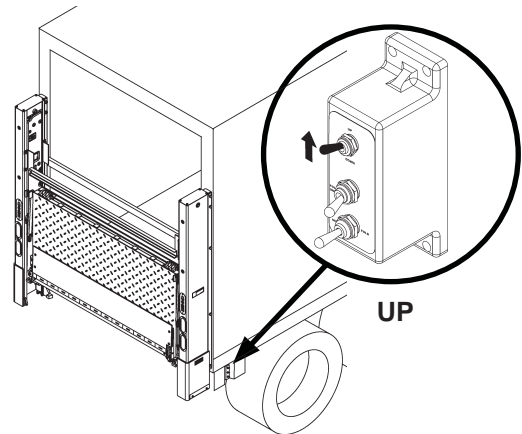

**PRESSURIZING LIFTING CYLINDERS**  
**FIG. 43-1**

2. To pressurize closing cylinder, set control box toggle switches to **FOLD** for 10-15 seconds as shown in **FIG. 43-2**.

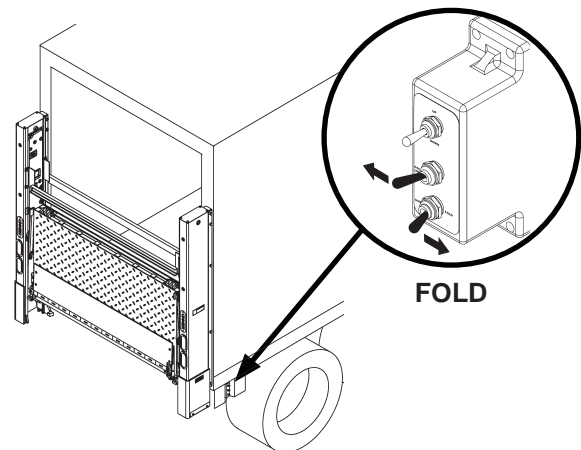

**PRESSURIZING CLOSING CYLINDER**  
**FIG. 43-2**

**NOTE:** Liftgate is shipped with **Exxon Univis HVI-13** hydraulic fluid in the hydraulic cylinders. This fluid is suitable for operation in temperature range of **-40° F to +120° F**. If necessary, a different brand or higher viscosity hydraulic fluid may be used. Refer to the **CHANGING HYDRAULIC FLUID** procedure in the **BMRA Maintenance Manual**.

## STEP 15 - OPTIMIZE HYDRAULIC FLUID LEVEL

1. Lower (**DOWN**) the platform about 6" using toggle switch settings shown in **FIG. 44-1**.

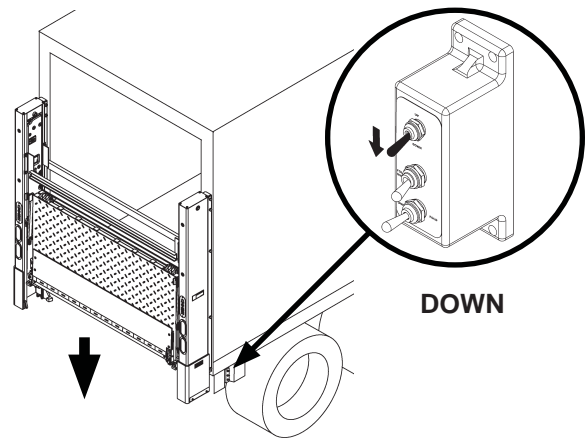

**LOWERING PLATFORM**  
**FIG. 44-1**

2. Open (**UNFOLD**) the platform by setting toggle switches as shown in **FIG. 44-2**.

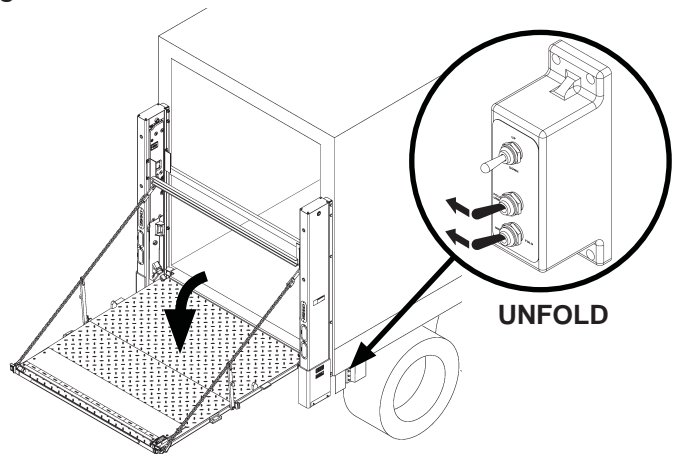

**UNFOLDING PLATFORM**  
**FIG. 44-2**

## STEP 15 - OPTIMIZE HYDRAULIC FLUID LEVEL - Continued

3. Close (**FOLD**) the platform by setting toggle switches as shown in **FIG. 45-1**. Then, open (**UNFOLD**) the platform by setting toggle switches as shown in **FIG. 45-2**.

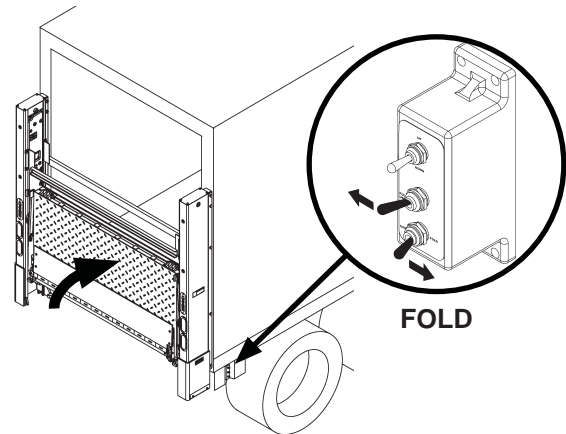

**FOLDING PLATFORM**  
**FIG. 45-1**

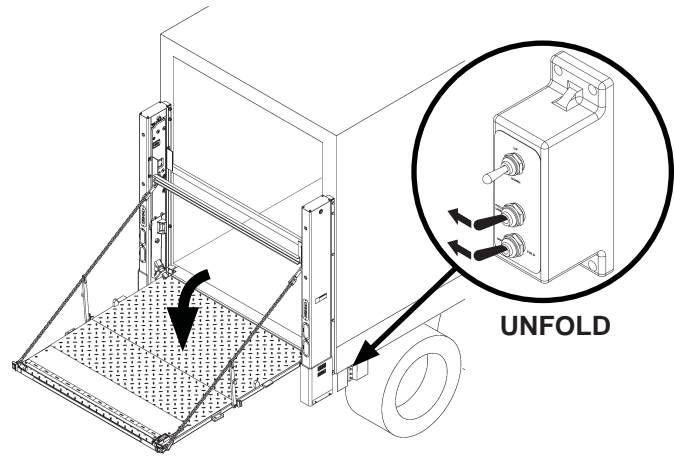

**UNFOLDING PLATFORM**  
**FIG. 45-2**

4. Lower (**DOWN**) the platform to ground level using the toggle switch settings shown in **FIG. 45-3**.

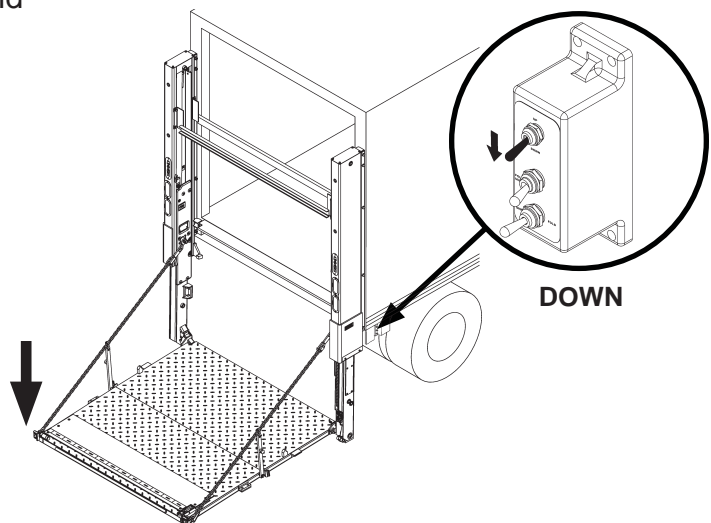

**LOWERING PLATFORM**  
**FIG. 45-3**

## STEP 15 - OPTIMIZE HYDRAULIC FLUID LEVEL - Continued

5. Raise (**UP**) the platform to bed height using toggle switch setting shown in **FIG. 46-1**.

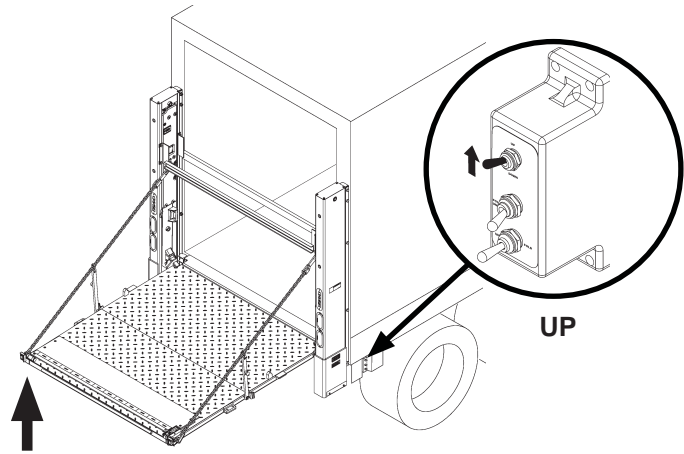

**RAISING PLATFORM**  
**FIG. 46-1**

6. Close (**FOLD**) the platform to stowed position by setting toggle switches as shown in **FIG. 46-2**.

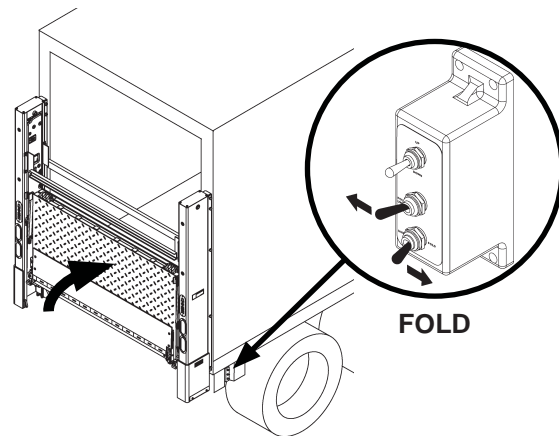

**FOLDING PLATFORM**  
**FIG. 46-2**

**NOTE:** Information for checking hydraulic fluid level is also shown on a decal inside the pump box cover.

7. Check if hydraulic fluid level is at the middle of sight glass (**FIG. 46-3**). If necessary, remove filler cap (**FIG. 46-3**) and add hydraulic fluid until level rises to middle of sight glass (**FIG. 46-3**). Then, reinstall filler cap (**FIG. 46-3**).

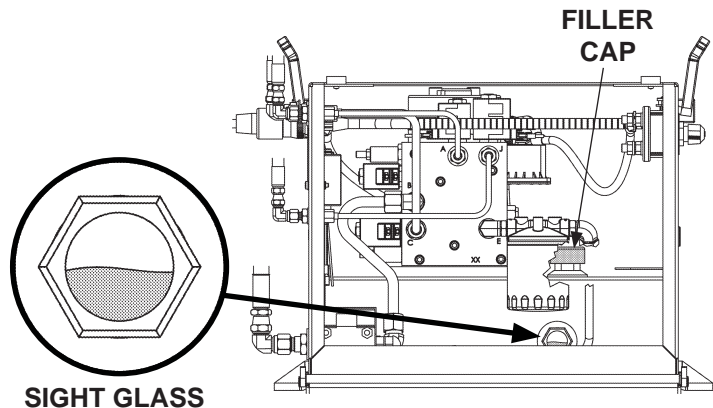

**CHECKING HYDRAULIC FLUID LEVEL**  
**FIG. 46-3**

## STEP 16 - FINISH WELDING LIFTGATE TO VEHICLE

### ⚠ WARNING

Recommended practices for welding on steel parts are contained in the current AWS (American Welding Society) D1.1 Structural Welding Code - Steel. Damage to Liftgate and/or vehicle, and personal injury can result from welds that are done incorrectly.

**NOTE:** Refer to **INSTALLED LIFTGATE** in the **VEHICLE REQUIREMENTS** section of this manual.

**NOTE:** There are 2 methods of welding the Liftgate to vehicle body: 1.) Weld mounting brackets (if equipped) to body or 2.) weld columns directly to body.

**NOTE:** If the Liftgate was used as a fixture to position the column mounting brackets and those brackets are mild steel, the Liftgate must be removed to paint the brackets. Remove the Liftgate only after the brackets are welded to vehicle.

### CAUTION

Some mild steel Liftgate mounting channels and extension plates are coated with a protective film and shipped unpainted. The film, if not removed for painting, can cause paint to separate from surface. Use hot soapy water and rinse water to remove the protective film before painting.

**NOTE:** To remove protective film from unpainted mounting channels and extension plate, use hot soapy water and rinse water.

1. Disconnect power from pump by removing nut from negative (-) battery terminal and disconnect negative (-) battery cable (FIG. 47-1). Reinstall nut on negative (-) battery terminal.

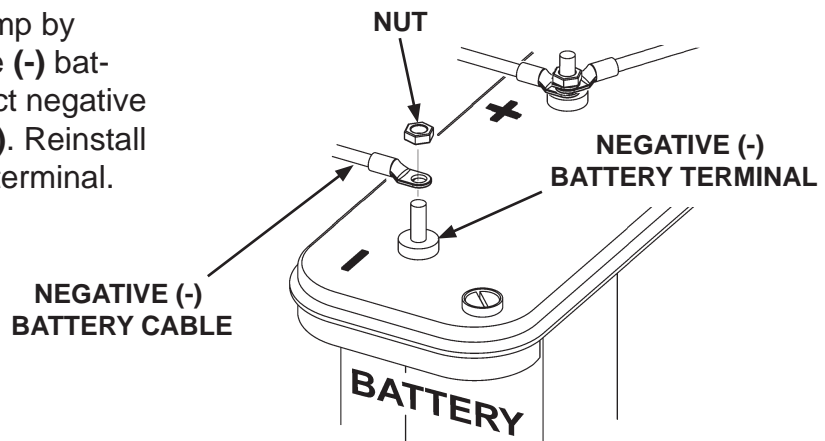

DISCONNECTING POWER  
FIG. 47-1



## STEP 16 - FINISH WELDING LIFTGATE TO VEHICLE - Continued

### CAUTION

To prevent damage to Liftgate, connect welder ground to vehicle body.

### ⚠ WARNING

Do not remove support fixtures before welding.

- Cover platform as shown in FIG. 48-1.

- Weld the Liftgate RH and LH columns or mounting brackets to vehicle body as shown in FIG. 48-1.

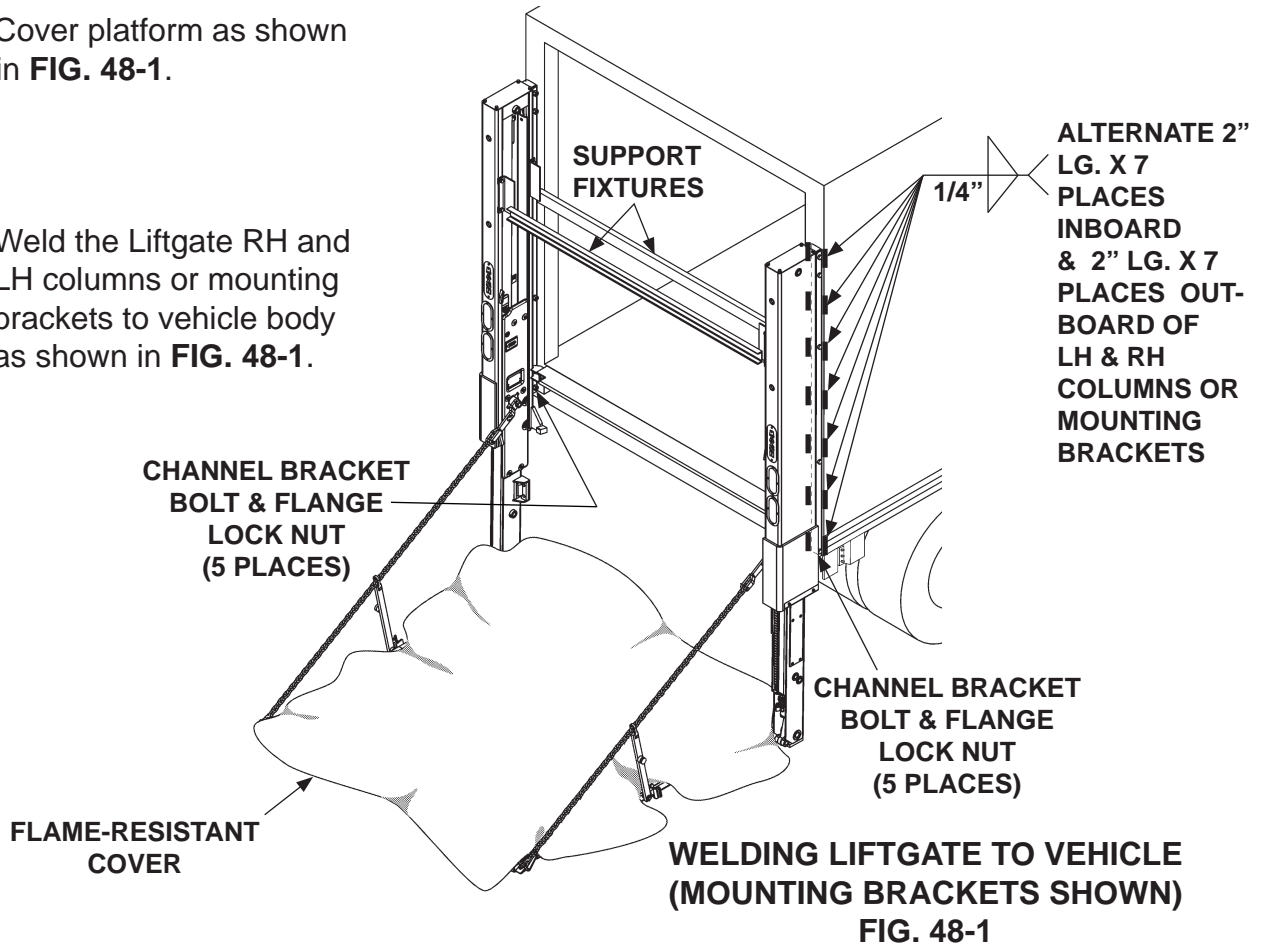

- Torque flange lock nuts and bolts to **100 lb-ft** for stainless steel brackets and **125 lb-ft** for standard steel brackets (FIG. 48-1).

# STEP 16 - FINISH WELDING LIFTGATE TO VEHICLE - Continued

## CAUTION

To prevent damage to Liftgate components, welder ground must be connected to vehicle body.

5. Make sure platform is at ground level to provide access to the extension plate.

## CAUTION

To protect the original paint system, a 3" wide area of paint must be removed from all sides of the weld area before welding.

6. Weld the top surface of extension plate (FIGS. 49-1 and 49-2) to vehicle body.

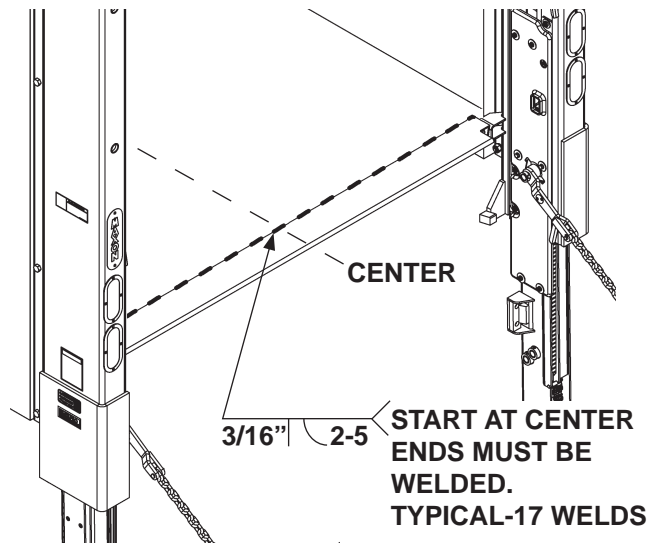

**WELDING TOP OF EXTENSION PLATE  
TO 96" WIDE VEHICLE  
FIG. 49-1**

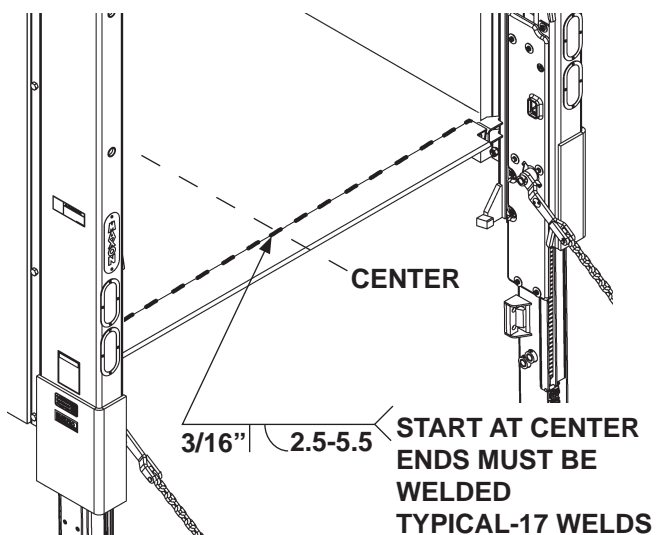

**WELDING TOP OF EXTENSION PLATE  
TO 102" WIDE VEHICLE  
FIG. 49-2**

# STEP 16 - FINISH WELDING LIFTGATE TO VEHICLE - Continued

**NOTE:** After welding top of extension plate, if you see a gap between bottom of extension plate & vehicle body sill, fill the gap. Fill the gap with A-36 general purpose steel and the same welds shown in **FIGS. 50-1 & 50-2**.

7. Weld the bottom surface of extension plate (**FIGS. 50-1 and 50-2**) to vehicle body.

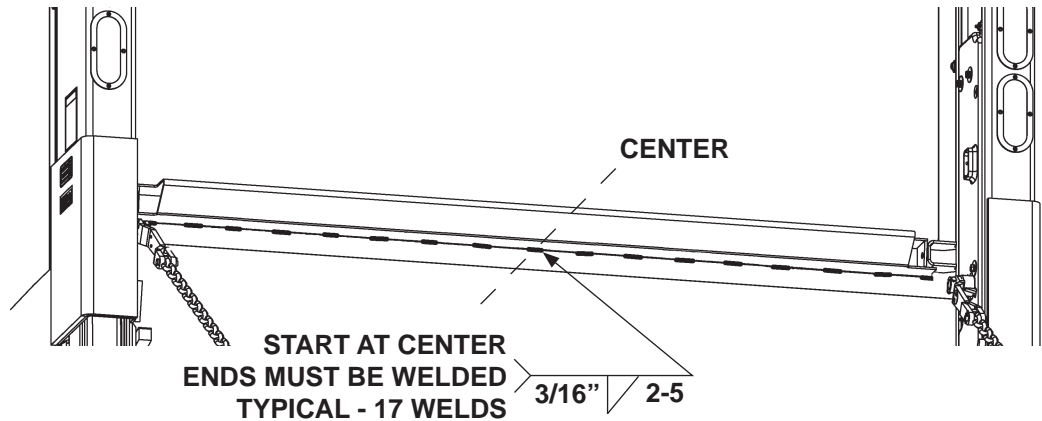

**WELDING BOTTOM OF EXTENSION PLATE  
TO 96" WIDE VEHICLE  
FIG. 50-1**

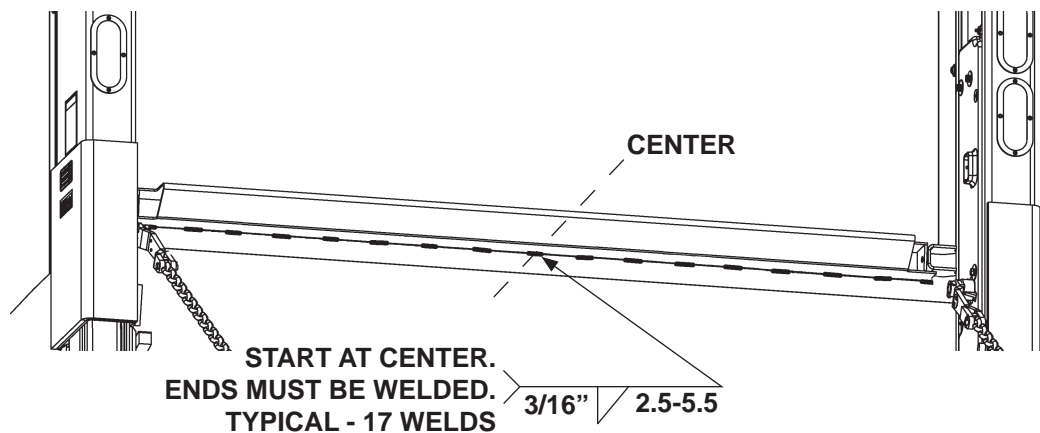

**WELDING BOTTOM OF EXTENSION PLATE  
TO 102" WIDE VEHICLE  
FIG. 50-2**

# STEP 16 - FINISH WELDING LIFTGATE TO VEHICLE - Continued

8. Reconnect negative (-) battery cable to negative (-) battery terminal (**FIG. 51-1**). Then, reinstall nut on negative (-) battery terminal (**FIG. 51-1**).

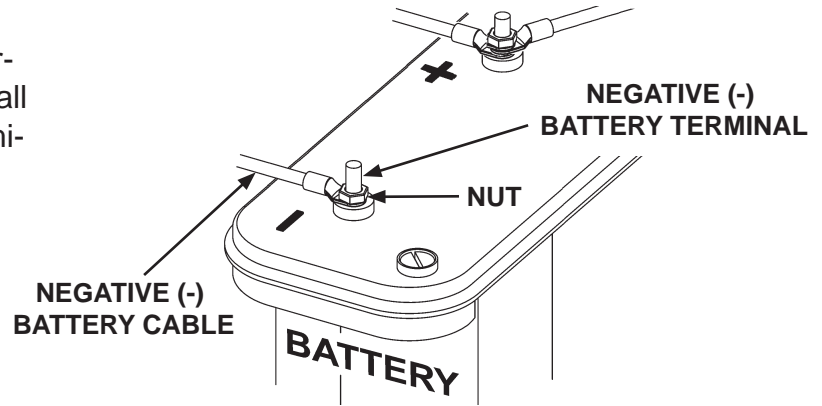

RECONNECTED BATTERY CABLES  
FIG. 51-1

# STEP 17 - PLATFORM CHAIN ADJUSTMENT

1. Lower the platform to ground level.  
Check if tip of the flipover and bottom of the runners touch the ground at the same time (**FIG. 52-1**).

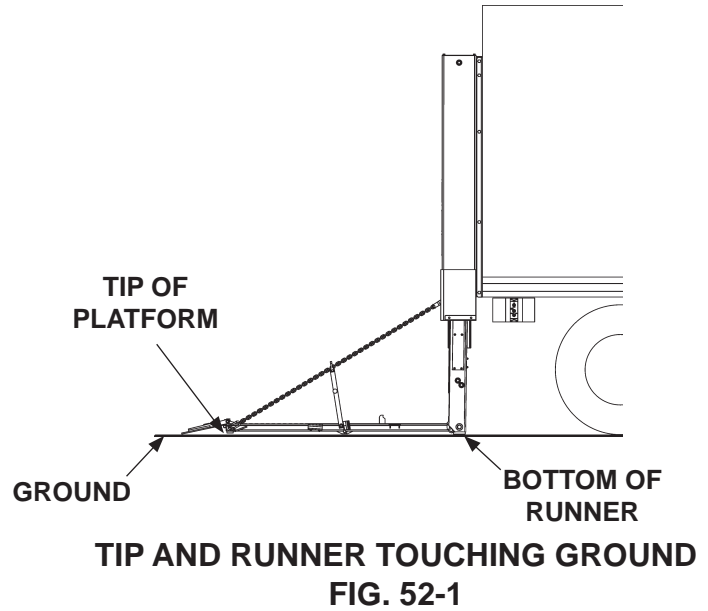

2. If the bottom of the runners are off the ground, measure the distance “H1” (**FIG. 52-2**) from the ground to the bottom of the runners.

- Adjustment is not required if distance “H1” is 1” or less.
- If distance “H1” is more than 1”, refer to the steps that follow to adjust the platform chains.

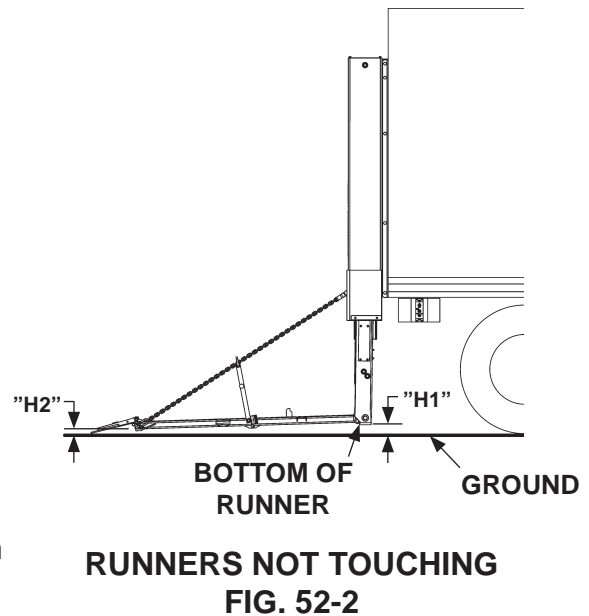

3. Refer to measured distance “H1” at the runners and **TABLE 52-1**. Note the method(s) that will be required to raise the tip of platform (or retention ramp) the expected distance.

| MEASURED “H1”<br>(AT RUNNER) | ADJUSTMENT METHODS<br>(● REQUIRED FOR EXPECTED RISE AT TIP) |   | EXPECTED RISE<br>“H2” (AT TIP) |
|------------------------------|---|---|--------------------------------|
|                              | REMOVE 1 LINK<br>OF BOTH CHAINS<br>(RAISES TIP 1-1/2”)      | REMOVE 2 LINKS<br>OF BOTH CHAINS<br>(RAISES TIP 3”) |                                |
| 1” - 2-1/4”                  | -   | -   | 0” - 1-1/4”                    |
| 2-1/2” - 3-3/4”              | ●   |   | 1-1/2” - 2-3/4”                |
| 4”                           | ●   | ●   | 3” - 4”                        |

**TABLE 52-1**

## STEP 17 - PLATFORM CHAIN ADJUSTMENT - Continued

4. Raise platform enough to remove supports. Then, lower platform to the ground (**FIG. 53-1**). Tip of flipover and runners should touch the ground at the same time as shown in **FIG. 53-1**. If necessary, repeat instructions **3 and 4** until tip of platform and runners touch ground at the same time.

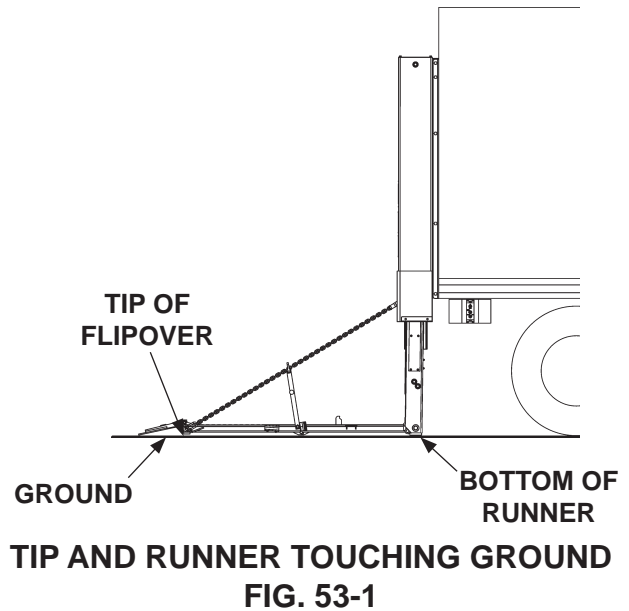

## STEP 18 - REMOVE UPPER SUPPORT FIXTURES

### ⚠ CAUTION

Upper support fixtures are heavy. To prevent injury to installer and damage to Liftgate, use forklift or hoist to hold support fixtures during removal.

1. Stow the platform as shown in **FIG. 54-1A**.
2. Position forklift or hoist to hold upper support fixtures as shown in **FIG. 54-1A**.
3. Unbolt the 2 upper support fixtures from the LH column (**FIGS. 54-1A and 54-1B**). Repeat for RH column. Remove upper support fixtures from work area.

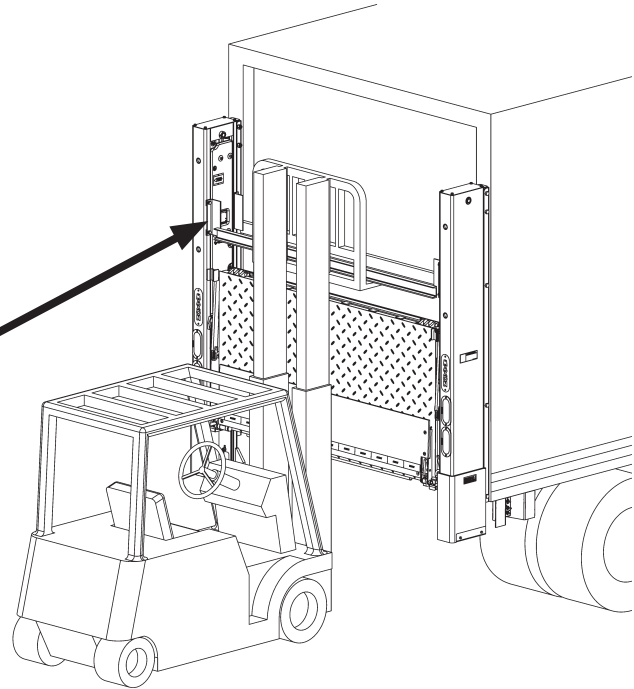

**FIG. 54-1A**

UPPER SUPPORT  
FIXTURES

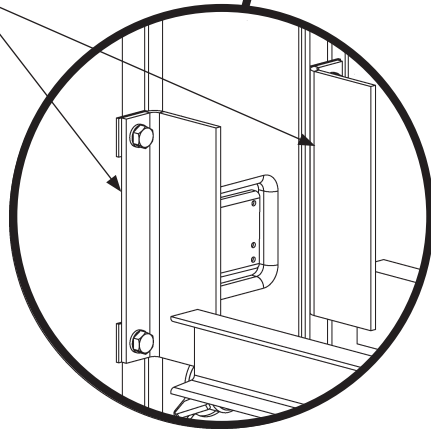

**FIG. 54-1B**



## STEP 19 - PLACE "ALIGN ARROWS" DECAL

**NOTE:** Make sure **RUNNERS** are raised all the way up (closest to top of **COLUMN**) before doing the following steps.

**NOTE:** If plastic cover is labelled with large arrow, the larger piece of arrow decal is not required.

1. Cut decal **H** (**FIG. 55-1**) on dashed lines to make 2 pieces as shown in **FIG. 55-2**. Peel backing from largest piece of decal and place it on steel runner cover, only (**FIG. 55-3**).
2. Peel backing from smallest piece of decal and place it on **COLUMN** as shown in **FIG. 55-3**.

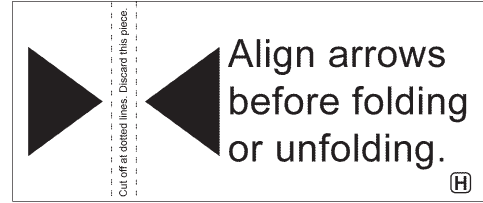

**FIG. 55-1**

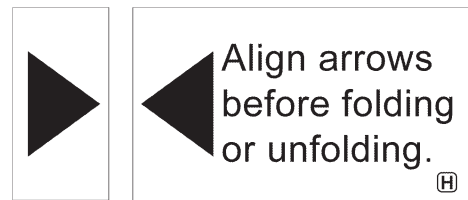

**FIG. 55-2**

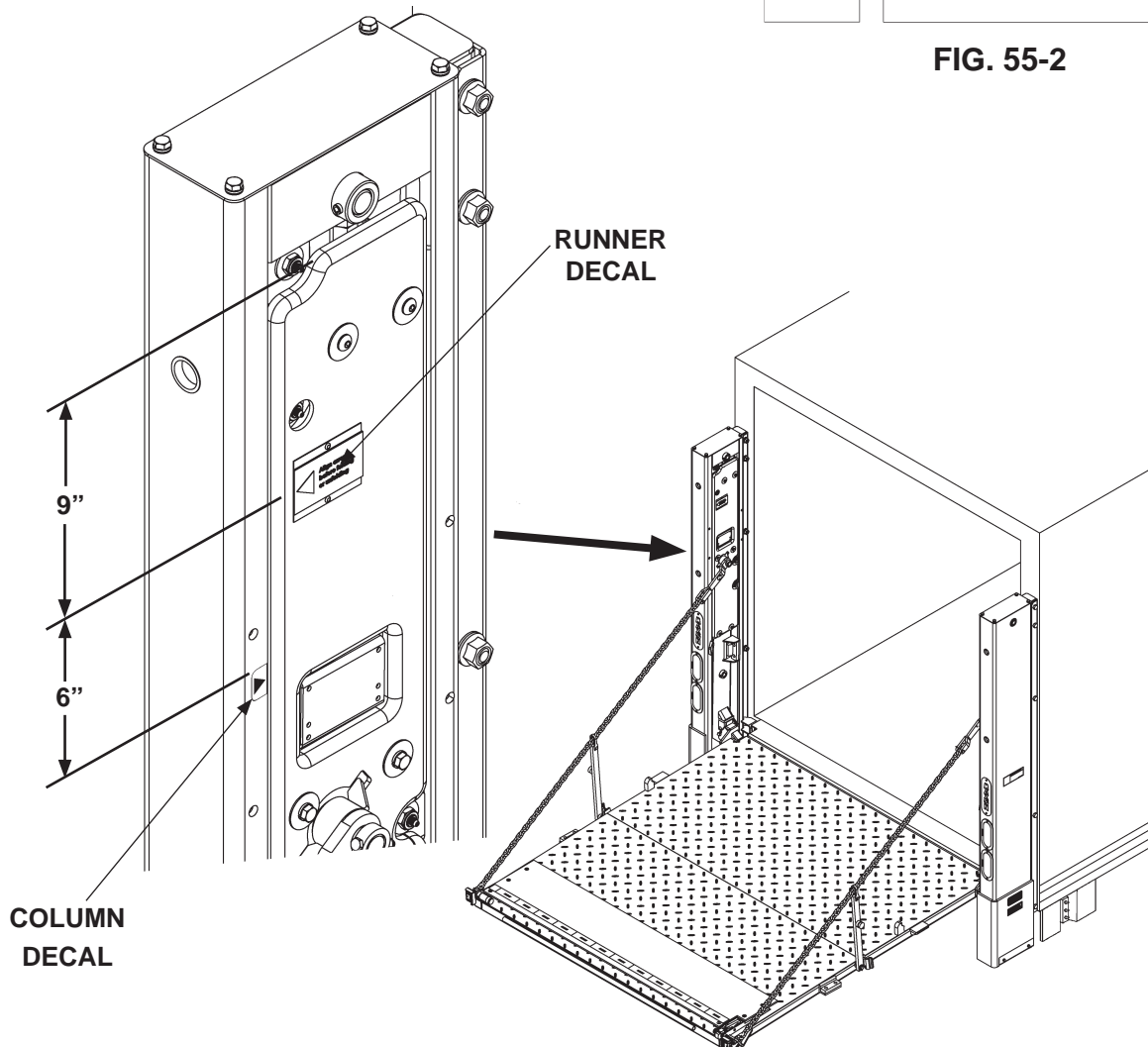

**FIG. 55-3**

## STEP 20 - ADJUST PLATFORM ASSEMBLY

1. Ensure aluminum platform is completely unfolded (**FIG. 56-1**). Use long straight edge to determine if top surface of platform is flush with top surface of flipover as shown in **FIG. 56-1**.

**NOTE:** Recommend turning bolt in 60° increments so flats of the adjuster bolt are parallel to vertical surface of side plates.

2. If flipover requires adjustment, fold platform enough to gain access to adjustment bolt on each side of platform (**FIG. 56-2**). Next, loosen locking nut for each adjuster bolt (**FIG. 56-2**). Then, alternately turn each bolt clockwise to raise tip of flipover or counter-clockwise to lower tip of flipover. Repeat 1 to check. When platform and flipover are flush, torque both locking nuts to **192 lb-ft**.

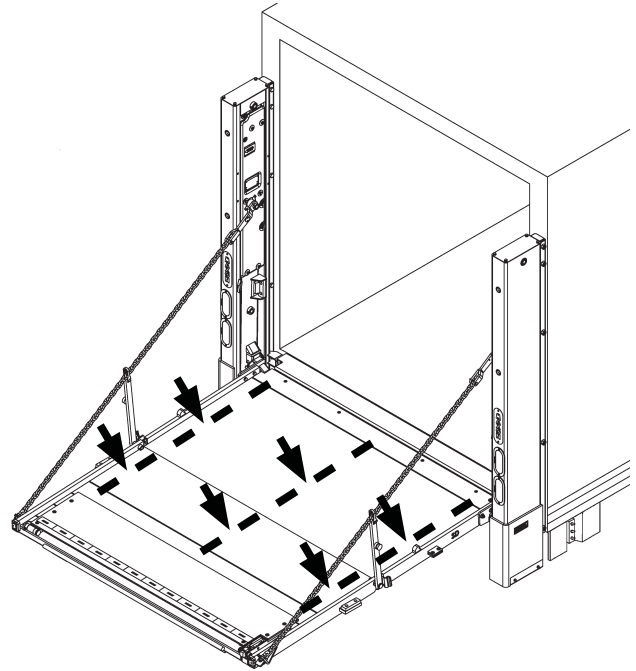

**ARROWS INDICATE WHERE TO CHECK IF PLATFORM & FLIPOVER ARE FLUSH**  
**FIG. 56-1**

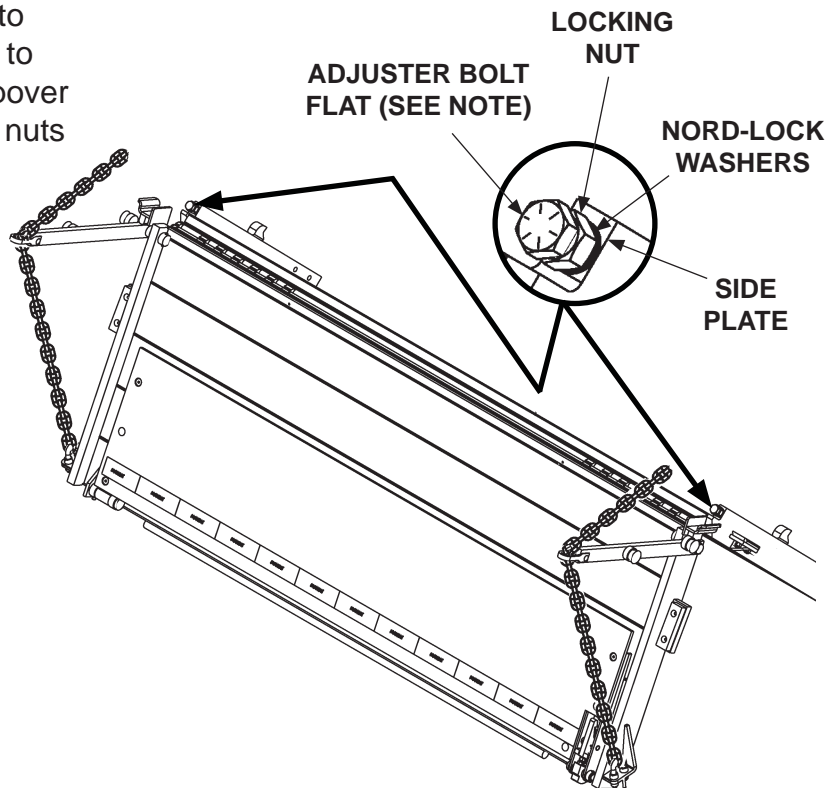

**PLATFORM ADJUSTMENT BOLT**  
**FIG. 56-2**

## STEP 21 - ACTIVATE PLATFORM LIGHTS

1. Activate the flashing platform lights by cutting the wire from the center of the link wire on both RH and LH flashing lights (**FIG. 57-1**).

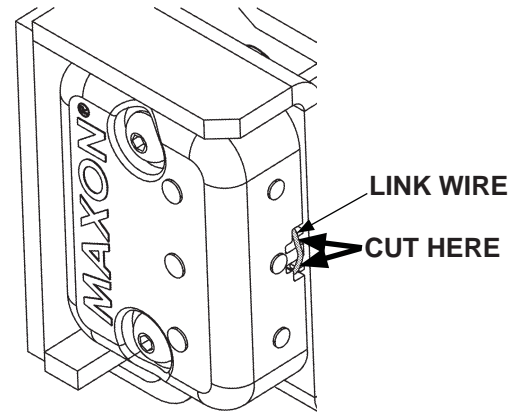

**ACTIVATING PLATFORM LIGHTS  
FIG. 57-1**

2. Fold platform. Lights should stop flashing.

# ATTACH DECALS

**NOTE:** Ensure there is no residue, dirt, or corrosion where decals are attached. If necessary, clean surface before attaching decals.



**CAUTION DECAL (2 PLACES)**  
(LABEL IS PART OF PLASTIC COVER)  
P/N 266508-01

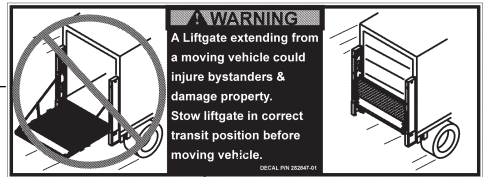

**STOW WARNING DECAL**  
P/N 282847-01

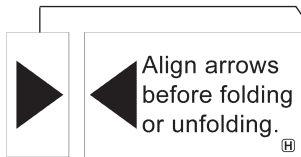

**DECAL "H"**  
(LABEL IS PART OF PLASTIC COVER)

**SERIAL PLATE**

**FAMILY OWNED DECAL**  
P/N 283445-01

**PAINT DECAL**  
P/N 267338-01

**DECAL "F"**  
(2 PLACES)

**DECAL "G"**

**DECAL "C"**

**DECAL "D"**

**DECAL "B"**

**DECAL "A"**



**FAMILY OWNED DECAL**  
(2 PLACES)  
P/N 283445-01

**DECAL "E"**

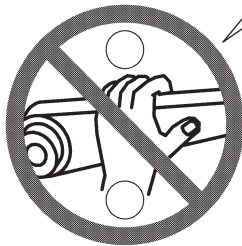

**KEEP HANDS CLEAR**  
(2 PLACES)  
P/N 260009



**PAINT DECAL**  
(2 PLACES)  
P/N 267338-01

**FIG. 58-1**

# DECALS - Continued

**SAFETY INSTRUCTIONS**

Read all decals and operation manual before operating liftgate.

1. Do not use liftgate unless you have been properly instructed and have read, and are familiar with, the operating instructions.
2. Be certain vehicle is properly and securely braked before using the liftgate.
3. Always inspect this liftgate for maintenance or damage before using it. Do not use liftgate if it shows any sign of damage or improper maintenance.
4. Do not overload
5. Make certain the area in which the platform will open and close is clear before opening or closing the platform.
6. Make certain platform area, including the area in which loads may fall from platform, is clear before and at all times during operation of liftgate.
7. This liftgate is intended for loading and unloading of cargo only. Do not use this liftgate for anything but its intended use.

**A**

**WARNING**

Read this information carefully.

- Improper operation of this Liftgate can result in serious personal injury. If you do not have a copy of the operating instructions, please obtain them from your employer, distributor, or lessor before you attempt to operate Liftgate.
- If there are signs of improper maintenance, damage to vital parts, or slippery platform surface, do not use the Liftgate until these problems have been corrected.
- If you are using a pallet jack, be sure it can be maneuvered safely.
- Do not operate a forklift on the platform.
- Do not allow any part of yours or your helper's body to be placed under, within, or around any portion of the moving Liftgate, or its mechanisms, or in a position that would trap them between the platform and the ground or truck when the Liftgate is operated.
- If a helper is riding the platform with you, make sure you are both doing so safely and that you are not in danger of coming in contact with any moving or potentially moving obstacles.
- **USE GOOD COMMON SENSE.**
- If load appears to be unsafe, do not lift or lower it.

For a free copy of other manuals that pertain to this model Liftgate, please visit our website at [www.maxonlift.com](http://www.maxonlift.com) or call Customer Service at (800) 227-4116.

**B**

**THE MAXIMUM CAPACITY OF THIS LIFT IS**

**\_\_\_\_ LB [ \_\_\_\_ KG ]**

**WHEN THE LOAD IS CENTERED ON THE LOAD CARRYING PLATFORM**

**C**

**WARNING**

**Liftgate hazards can result in crushing or falling.**

**Keep hands and feet clear of pinch points.**

**If riding liftgate, make sure load is stable and footing is solid.**

**D**

Read and understand all instructions and WARNINGS before use.

**CAUTION**

**Always stand clear of platform area.**

**E**

**CAUTION**

**Do not grease columns.**

**F**

UP ↑

DOWN ↓

**G**

**Align arrows before folding or unfolding.**

**H**

(RH PORTION OF LABEL IS PART OF PLASTIC COVER)

**DECAL SHEET  
FIG. 59-1**

| MODEL   | ORDER P/N | DECAL "C"           |
|---------|-----------|---------------------|
| BMRSD35 | 268309-01 | 3500 LBS. [1600 KG] |
| BMRSD44 | 268309-02 | 4400 LBS. [2000 KG] |
| BMRSD55 | 268309-03 | 5500 LBS. [2500 KG] |
| BMRSD66 | 268309-04 | 6600 LBS. [3000 KG] |

**DECAL SHEET PART NUMBERS  
TABLE 59-1**

**MAXON**<sup>®</sup> 11921 Slauson Ave. Santa Fe Springs, CA. 90670 (800) 227-4116 FAX (888) 771-7713

## TOUCHUP PAINTED OR GALVANIZED FINISH

### CAUTION

Damaged cylinder seals and contaminated hydraulic fluid can result from painting the polished portion of the cylinder rod. To prevent damage, protect the exposed polished portion of the cylinder rod while painting.

- If bare metal or primer is exposed on the painted portions of the Liftgate, touch up the paint. To maintain the protection provided by the original paint system, **MAXON** recommends aluminum primer touchup paint kit, **P/N 908134-01**.
- If bare metal is exposed on galvanized portions of the Liftgate, touch up the galvanized finish. To maintain the protection provided by the original galvanized finish, **MAXON** recommends cold galvanize spray, **P/N 908000-01**.

# OPTIONS

## RECOMMENDED LIFTGATE POWER CONFIGURATION

**NOTE:** Make sure the Liftgate power unit, and all batteries on the vehicle for the power unit, are connected correctly to a common chassis ground.

1. Liftgate, pump box, and battery box are typically installed on trailers as shown in **FIG. 61-1**.

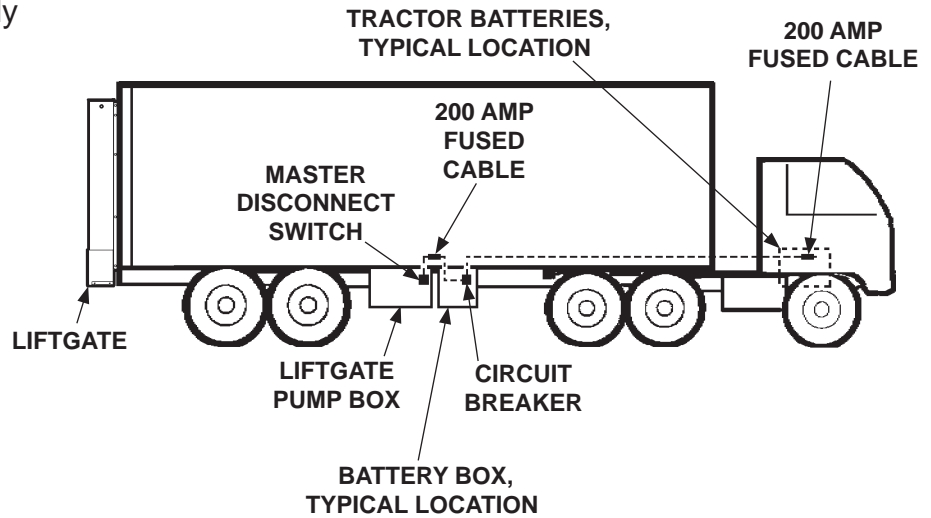

**RECOMMENDED LIFTGATE & BATTERY BOX  
INSTALLATION ON TRAILER  
FIG. 61-1**

# OPTIONS

## RECOMMENDED LIFTGATE POWER CONFIGURATION - Continued

**NOTE:** Make sure the Liftgate power unit, and all batteries on the vehicle for the power unit, are connected correctly to a common chassis ground.

2. Liftgate, pump box, and optional battery box are typically installed on trucks as shown in **FIG. 62-1** and **FIG. 62-2**. See the following page for battery and cable connections.

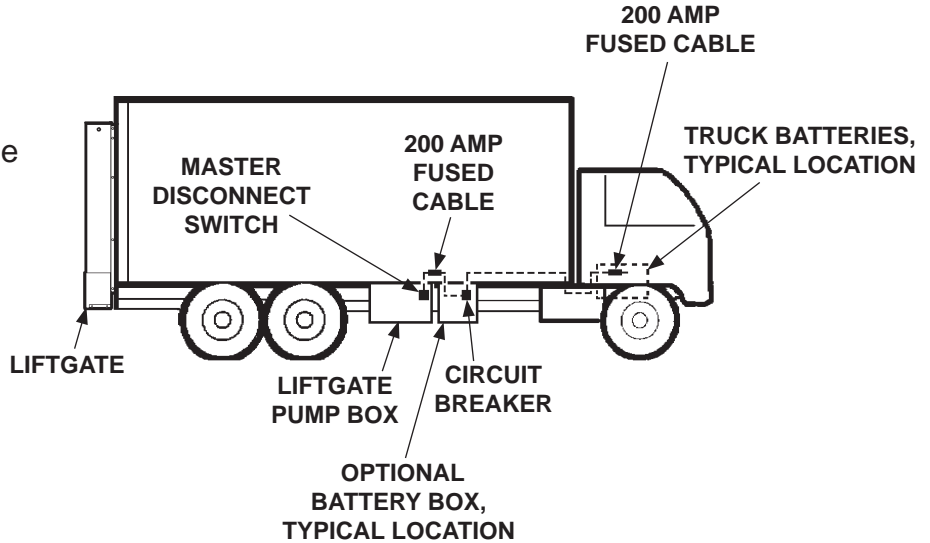

**RECOMMENDED LIFTGATE & BATTERY BOX INSTALLATION ON TRUCK**  
**FIG. 62-1**

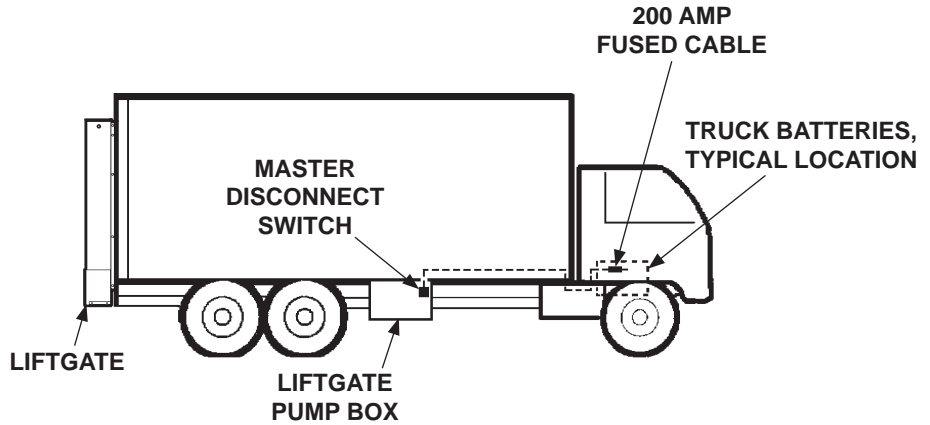

**RECOMMENDED LIFTGATE INSTALLATION ON TRUCK**  
**FIG. 62-2**

11921 Slauson Ave. Santa Fe Springs, CA. 90670 (800) 227-4116 FAX (888) 771-7713  
**MAXON**



# OPTIONS

## RECOMMENDED LIFTGATE POWER CONFIGURATION - Continued

**NOTE:** Always connect fused end of power cable to battery positive (+) terminal.

**NOTE:** MAXON recommends using dielectric grease on all electrical connections.

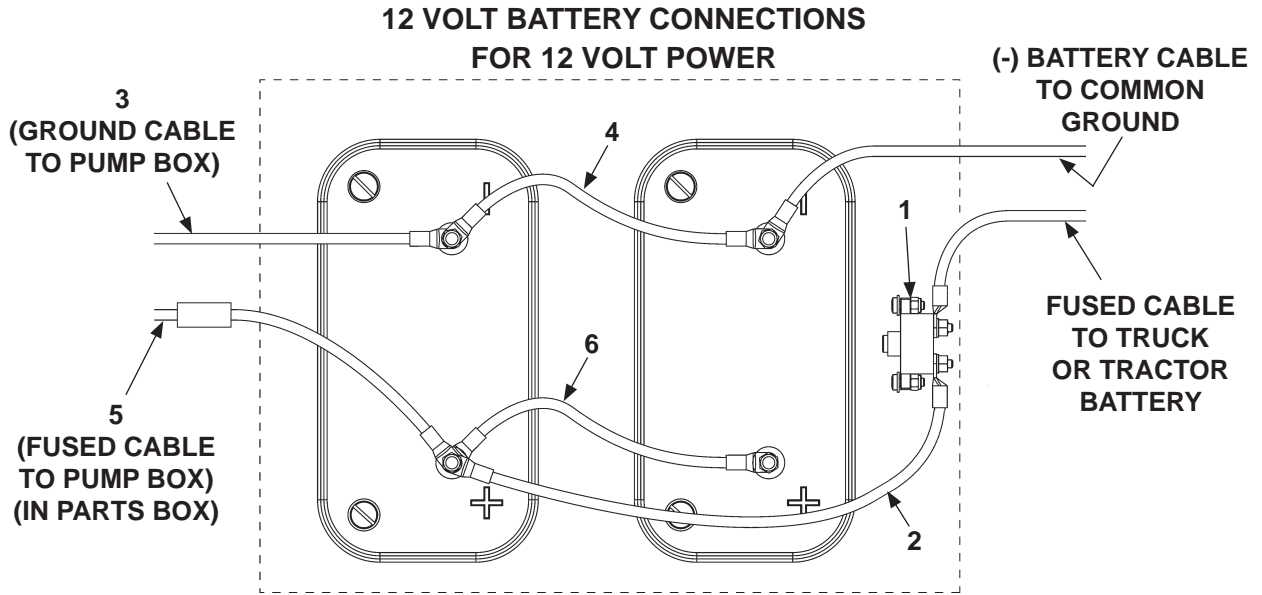

FIG. 63-1

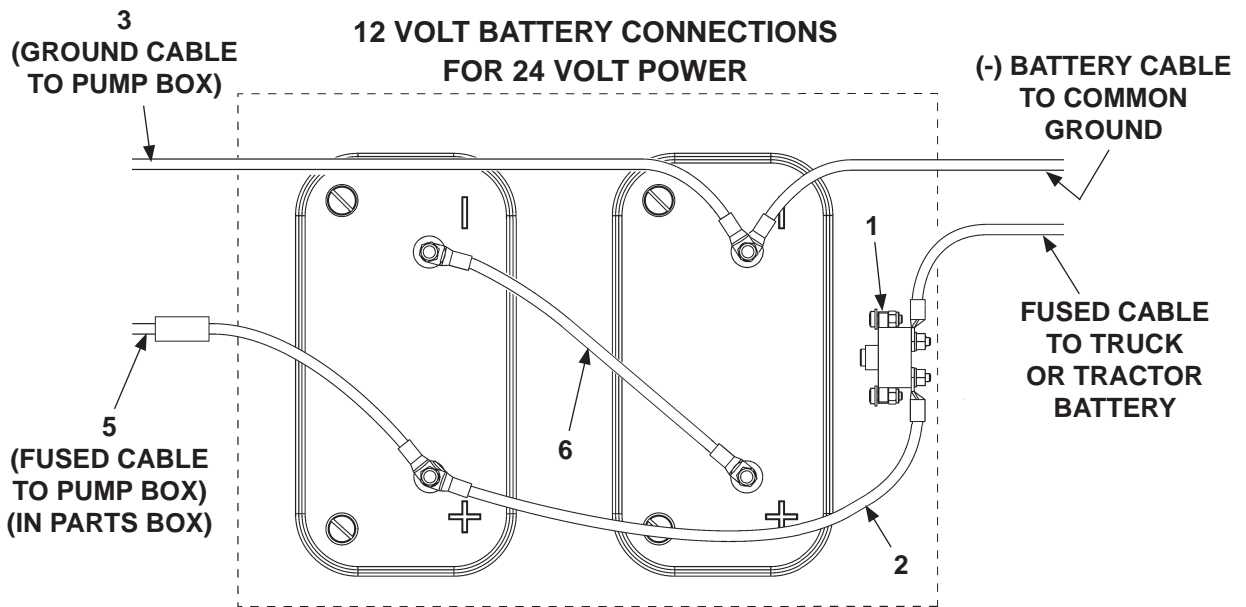

FIG. 63-2

| ITEM | QTY | PART NO.  | DESCRIPTION                            |
|------|-----|-----------|--|
| 1    | 1   | 221736    | CIRCUIT BREAKER 150 AMP                |
| 2    | 1   | 269308-18 | CABLE ASSEMBLY, 2 GA (RED),18" LG.     |
| 3    | 1   | 268226-06 | CABLE ASSEMBLY, 2 GA, 74" LG.          |
| 4    | 1   | 251871-14 | CABLE ASSEMBLY, 2 GA, 10" LG           |
| 5    | 1   | 285487-02 | CABLE ASSEMBLY, 2 GA, 200 AMP, 42" LG. |
| 6    | 1   | 269308-10 | CABLE ASSEMBLY, 2 GA (RED),10" LG.     |

**TABLE 64-1**

# HYDRAULIC SYSTEM DIAGRAMS

## PUMP & MOTOR SOLENOID OPERATION - POWER DOWN

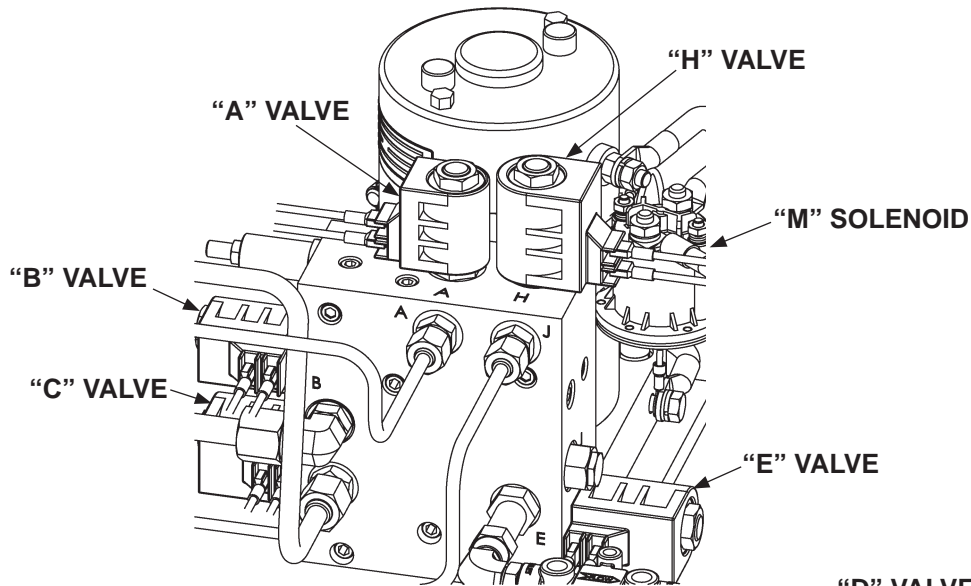

**PUMP ASSEMBLY  
FIG. 65-1**

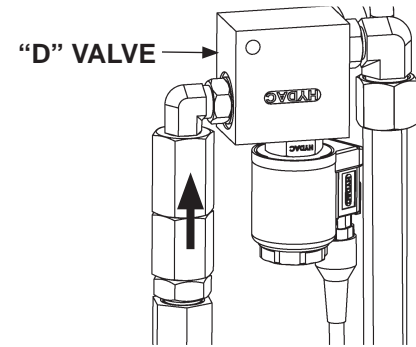

**"D" VALVES  
(TOP OF EACH COLUMN)  
FIG. 65-2**

| POWER UNIT MOTOR & SOLENOID OPERATION - POWER DOWN |      |  |       |       |           |           |           |           |           |           |
|--|------|--|-------|-------|-----------|-----------|-----------|-----------|-----------|-----------|
| LIFTGATE FUNCTION                                  | PORT | SOLENOID OPERATION (✓ MEANS ENERGIZED) |       |       |           |           |           |           |           |           |
|  |      | SWITCH                                 | RELAY | MOTOR | VALVE "A" | VALVE "B" | VALVE "C" | VALVE "D" | VALVE "E" | VALVE "H" |
| LIFT   | B    | "PD"                                   | -     | ✓     | -         | -         | -         | -         | -         | -         |
| LOWER  | C    |  | -     | ✓     | -         | ✓         | ✓         | ✓         | -         | -         |
| OPEN   | J    |  | -     | ✓     | ✓         | -         | -         | -         | ✓         | ✓         |
| CLOSE  | A    |  | -     | ✓     | -         | -         | -         | -         | ✓         | -         |

REFER TO VALVES SHOWN ON HYDRAULIC SCHEMATIC

**TABLE 65-1**

# HYDRAULIC SYSTEM DIAGRAMS

## PUMP & MOTOR SOLENOID OPERATION - GRAVITY DOWN

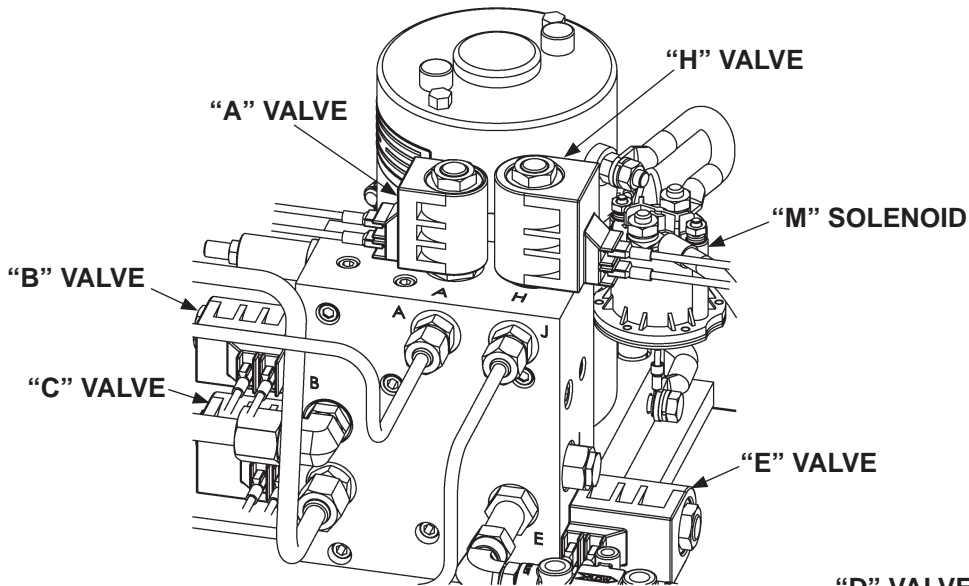

**PUMP ASSEMBLY**  
**FIG. 66-1**

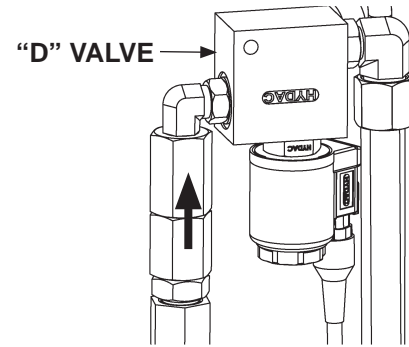

**"D" VALVES**  
**(TOP OF EACH COLUMN)**  
**FIG. 66-2**

| POWER UNIT MOTOR & SOLENOID OPERATION - GRAVITY DOWN |      |   |       |       |           |           |           |           |           |           |
|--|------|---|-------|-------|-----------|-----------|-----------|-----------|-----------|-----------|
| LIFTGATE FUNCTION                                    | PORT | SOLENOID OPERATION ( ✓ MEANS ENERGIZED) |       |       |           |           |           |           |           |           |
|  |      | SWITCH                                  | RELAY | MOTOR | VALVE "A" | VALVE "B" | VALVE "C" | VALVE "D" | VALVE "E" | VALVE "H" |
| LIFT   | B    | "GD"                                    | -     | ✓     | -         | -         | -         | -         | -         | -         |
| LOWER  | C    |   | ✓     | -     | -         | ✓         | -         | ✓         | -         | -         |
| OPEN   | J    |   | -     | ✓     | ✓         | -         | -         | -         | ✓         | ✓         |
| CLOSE  | A    |   | -     | ✓     | -         | -         | -         | -         | ✓         | -         |
| REFER TO VALVES SHOWN ON HYDRAULIC SCHEMATIC         |      |   |       |       |           |           |           |           |           |           |

**TABLE 66-1**

# HYDRAULIC SYSTEM DIAGRAMS

## SINGLE PUMP BOX HYDRAULIC SCHEMATIC

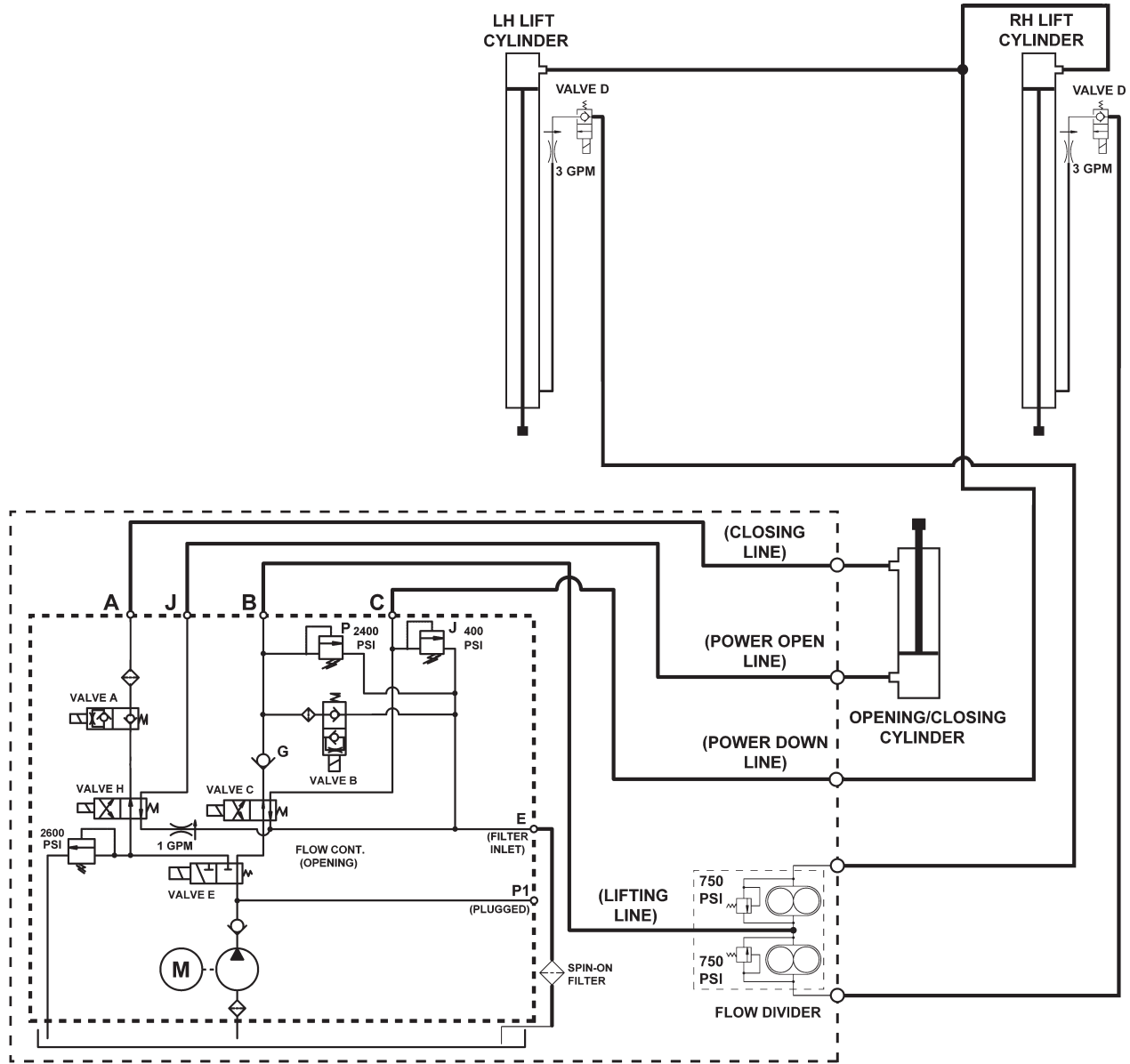

FIG. 67-1

# HYDRAULIC SYSTEM DIAGRAMS

## DUAL PUMP BOX HYDRAULIC SCHEMATIC

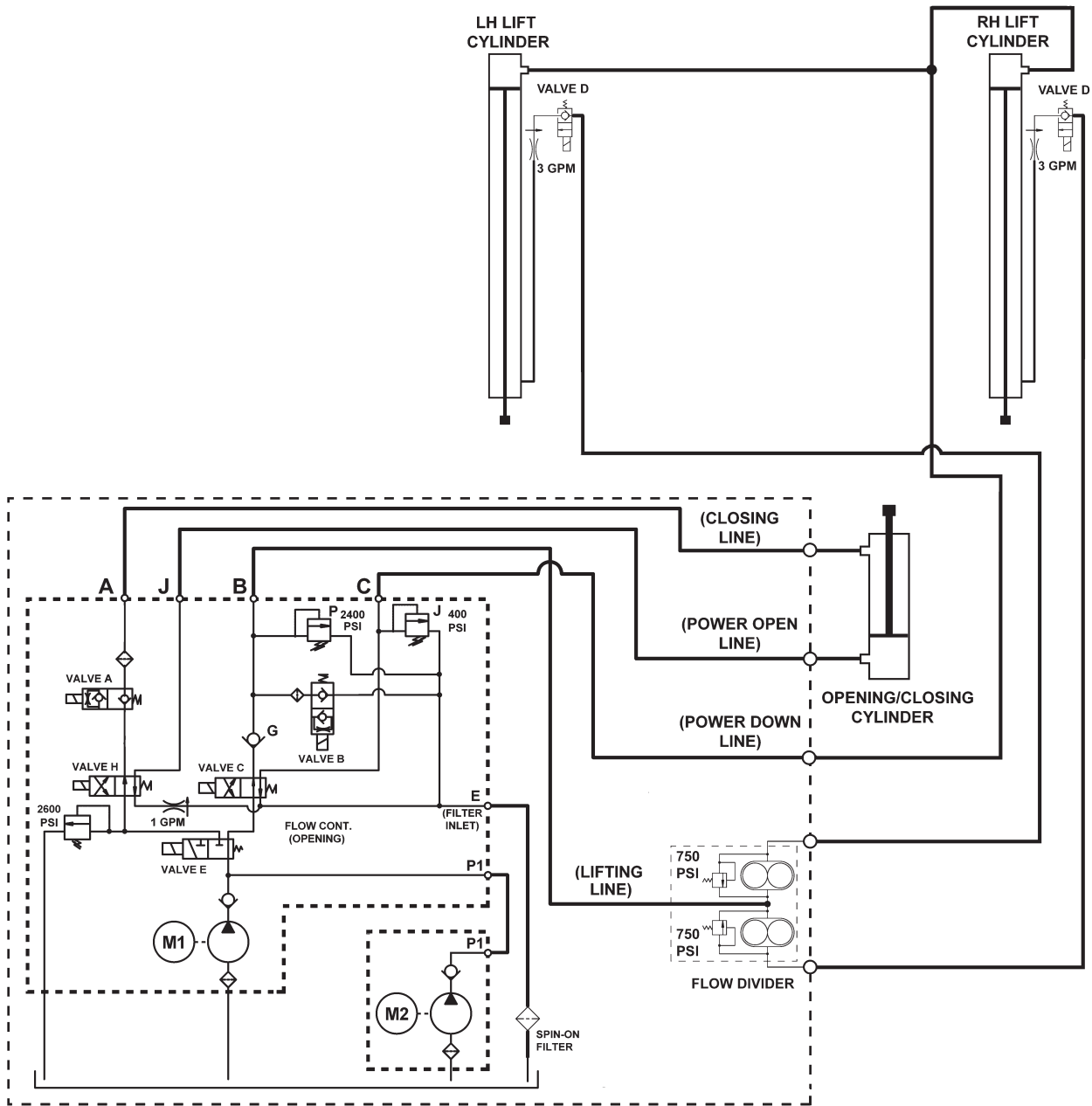

FIG. 68-1

# ELECTRICAL SYSTEM DIAGRAMS

## INTERCONNECTING ELECTRICAL SCHEMATIC

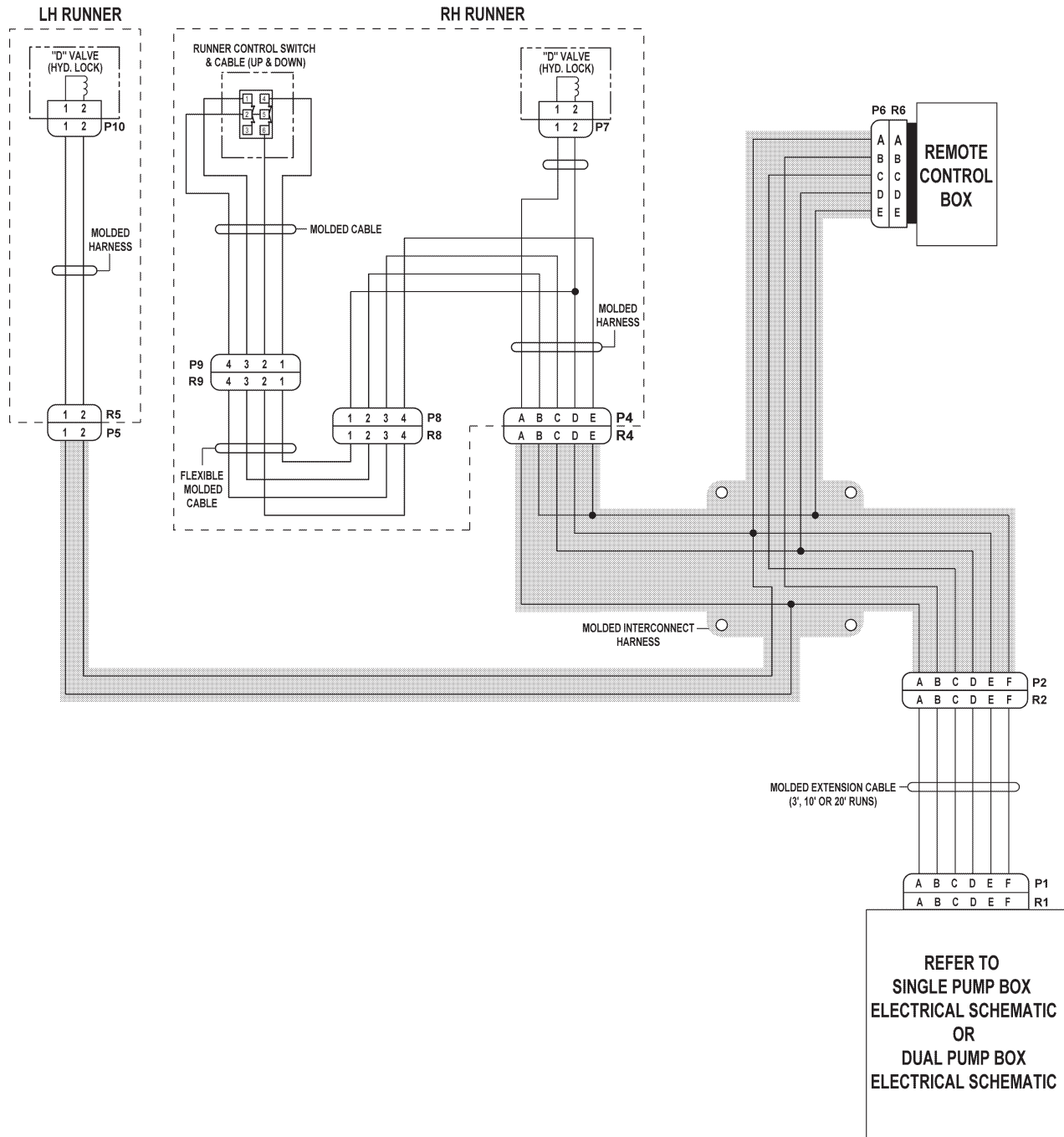

FIG. 69-1

11921 Slauson Ave. Santa Fe Springs, CA. 90670 (800) 227-4116 FAX (888) 771-7713  
**MAXON**®

# ELECTRICAL SYSTEM DIAGRAMS

## SINGLE PUMP BOX ELECTRICAL SCHEMATIC

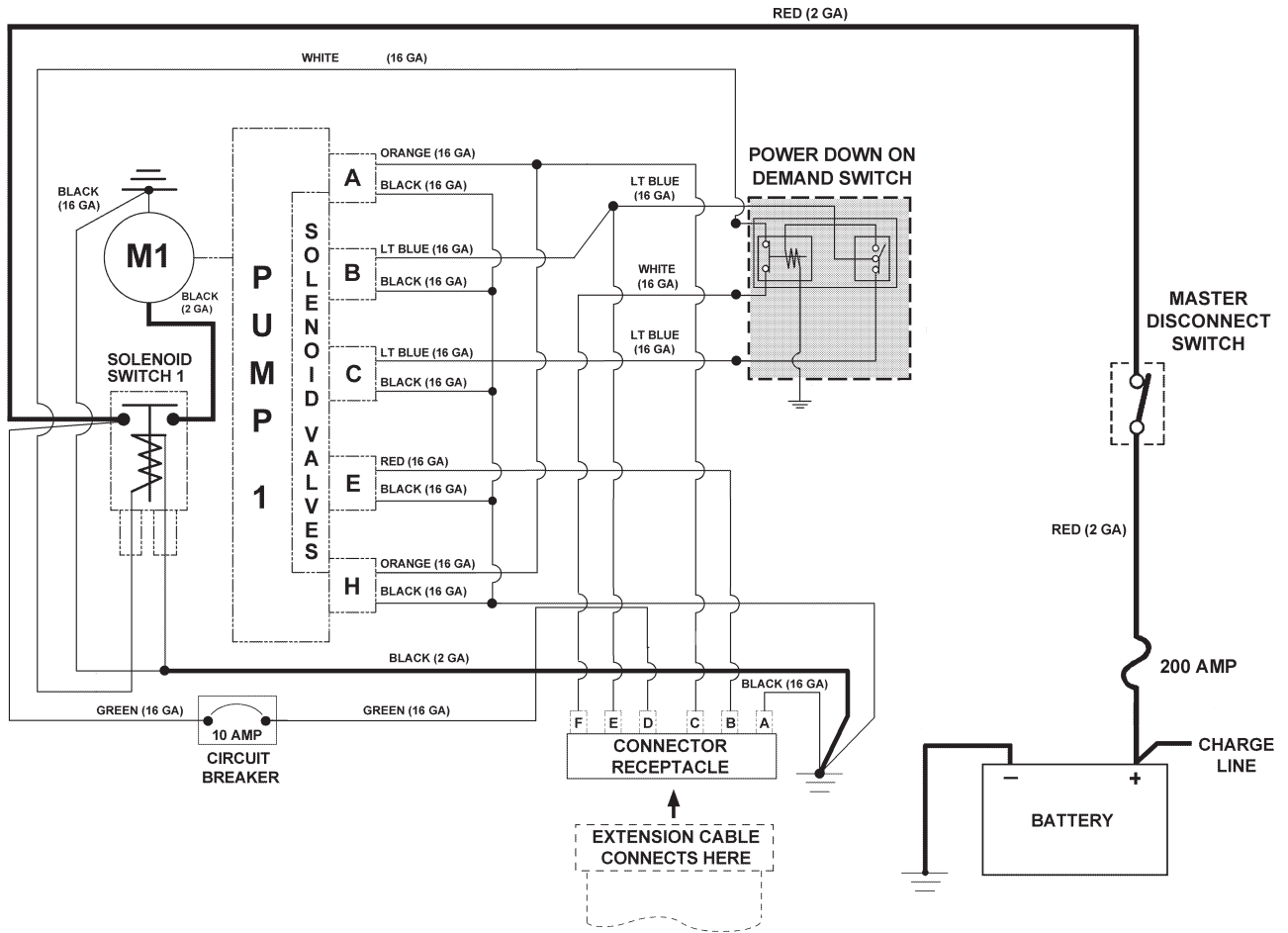

FIG. 70-1



# ELECTRICAL SYSTEM DIAGRAMS

## DUAL PUMP BOX ELECTRICAL SCHEMATIC

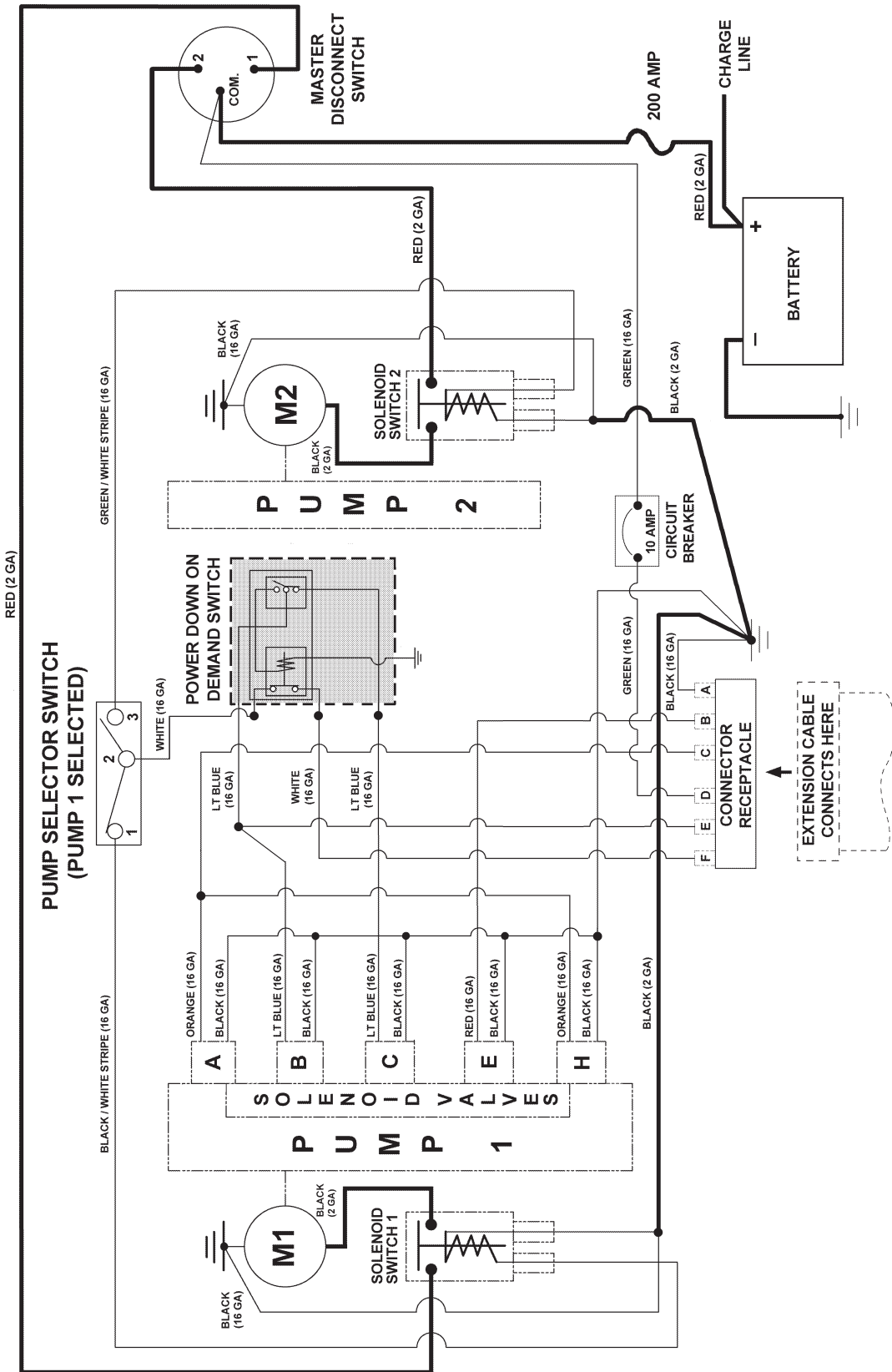

FIG. 71-1

# MAXON®

## PRE-DELIVERY INSPECTION FORM

Model: \_\_\_\_\_

Date: \_\_\_\_\_

Serial Number: \_\_\_\_\_

Technician: \_\_\_\_\_

### Pre-Installation Inspection:

- Correct model
- Correct capacity
- Correct platform size
- Correct options
- Manuals & decals

### Structural Inspection:

- Inspect alignment of final assembly
- Inspect pump box secure mounting
- Inspect all installation welds
- Check roll pins, bolts and fasteners
- Check for no twists in chain
- Check for torsion spring engagement
- Ensure platform ramp touches ground

### Hydraulic Inspection:

- Proper fluid level (See STEP 15 - OPTIMIZE HYDRAULIC FLUID LEVEL.)
- Check fittings for leaks in pump box
- Check fittings for leaks in columns

### Electrical Inspection:

- Check power/charge plug and terminal
- Check for loose wires and terminals
- Circuit breaker
- Battery hookup, 6 volt vs. 12 volt
- Check for fully charged batteries
- Inspect all solenoid connections
- Check all wiring harness connections
- Outside control box location
- Check electrical cable connections (at the bottom of the curb-side runner) tight and secure

### Operation Inspection:

**NOTE:** The following times are for 56" bed height, aluminum platform and flipover 86" W x 42" + 42" L, Exxon Univas HVI-13 oil, & temperature at 70°F. Times are for reference only and may vary for larger platforms, smaller platforms, steel platforms, or temperature changes.

- Check operation of outside control
- Check operation of runner control
- All BMRSD:** platform unfolds in 3 to 7 sec.
- All BMRSD:** platform folds in 3 to 7 sec.
- BMRSD-35 or -44 only**
- Unloaded platform lowers in **8 to 18 sec.**
- Platform loaded with 1000 lb (plus) lowers in **6 to 9 sec.**
- Unloaded platform raises in **9 to 21 sec.**
- BMRSD-55 or -66 only**
- Unloaded platform lowers in **12 to 23 sec.**
- Platform loaded with 1000 lb (plus) lowers in **11 to 14 sec.**
- Unloaded platform raises in **13 to 26 sec.**
- All BMRSD:** platform raises and lowers evenly. Maximum 1" difference from side to side.
- All BMRSD:** platform stores and locks securely behind both column wedges
- Check lift operation under load
- Decals in correct location and legible

11921 Slauson Ave. Santa Fe Springs, CA. 90670 (800) 227-4116 FAX (888) 771-7713

**MAXON®**

