

# INSTRUCTIONS, FORD F-150 & F-250 INSTALLATION KIT (C2 PICKUP LIFTGATES)

FORD F-150 & F-250 LIGHT DUTY PICKUP TRUCKS, 1997 - 2014

KIT P/N 289497-01

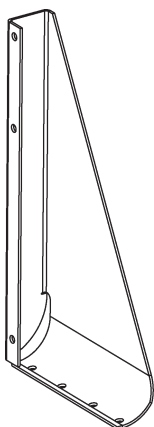

**MOUNTING BRACKET, LH**  
P/N 289640-01  
QTY. 1

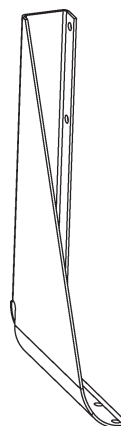

**MOUNTING BRACKET, RH**  
P/N 289640-02  
QTY. 1

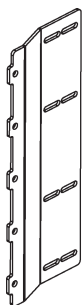

**MAIN FRAME  
MOUNTING BRACKET**  
P/N 289637-01  
QTY. 2

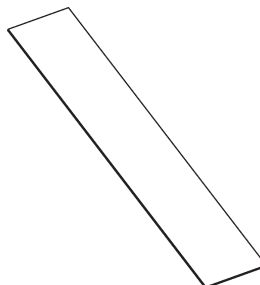

**FILLER STRIP**  
P/N 289648-01  
QTY. 3

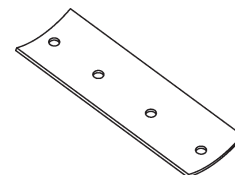

**BACKPLATE**  
P/N 289453-01  
QTY. 2

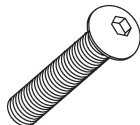
**BOLT KIT, P/N 289488-01**

**BUTTONHEAD SCREW**  
**3/8"- 16 X 1" LG.**  
**P/N 900064-05**  
**QTY. 8**



**PAN HEAD SCREW**  
**#10-24 X 3/4" LG.**  
**P/N 900753-07**  
**QTY. 8**

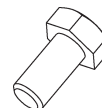

**HEX CAP SCREW**  
**3/16"-16 X 1" LG, GR5**  
**P/N 900778-02**  
**QTY. 12**



**LOCK WASHER, 3/8"**  
**P/N 902011-4**  
**QTY. 20**



**LOCK WASHER, 1/2"**  
**P/N 902011-6**  
**QTY. 6**

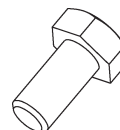

**HEX CAP SCREW**  
**1/2"- 13 X 1-1/4" LG, GR5**  
**P/N 900781-02**  
**QTY. 6**

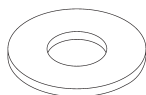

**FLAT WASHER, 3/8"**  
**P/N 902001-2**  
**QTY. 6**

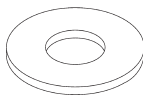

**FLAT WASHER,**  
**1-3/8" OD, 1/2"**  
**P/N 902014**  
**QTY. 4**

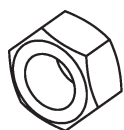

**HEX NUT, 3/8"-16**  
**P/N 903161-05**  
**QTY. 20**

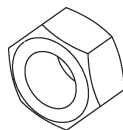

**LOCK NUT, 1/2"-13**  
**P/N 040066**  
**QTY. 4**

**NOTE:** C2 Liftgates are shipped with the following parts kits for installing the Liftgate.  
The parts are stored in the main frame housing.

### C2 LIFTGATE SMALL PARTS & MANUAL KIT P/N 289484-01

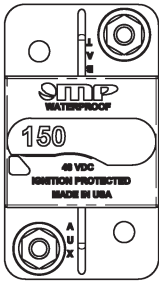

CIRCUIT BREAKER,  
150 AMP  
P/N 907207-01  
QTY. 1



LICENSE PLATE  
LIGHT  
P/N 907210-01  
QTY. 1

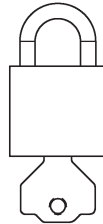

PADLOCK (2 KEYS)  
P/N 908221-01  
QTY. 1

LICENSE  
PLATE LIGHT  
INSTALLATION  
M-14-35

C2  
OPERATION  
MANUAL  
M-14-36



NYLON PLUG, 1/2"  
P/N 908081-01  
QTY. 5



LUG, 4GA  
COPPER, 3/8"  
P/N 907278-01  
QTY. 4



BUTT CONNECTOR,  
14-16 AWG  
P/N 030491  
QTY. 2



SELF-TAPPING SCREW,  
1/4"-20 X 5/8" LG.  
P/N 900705-02  
QTY. 2



PAN HEAD SCREW,  
#10-24 X 3/4" LG.  
P/N 900007-6  
QTY. 2



DROP-AWAY PIN  
P/N 289483-01  
QTY. 1



BREATHER PLUG, 3/8" NPT  
P/N 295049  
QTY. 1



GROMMET NUT, 1/4"  
P/N 901015-03  
QTY. 2



NUT, #10-24  
P/N 903163-02  
QTY. 2



LOCK NUT, 3/8"-16  
P/N 901016-4  
QTY. 1

### LOWER MOUNTING ANGLE

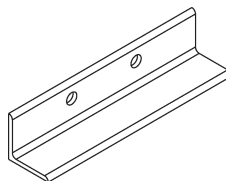

SHIPPING LEG  
P/N 289543-02  
QTY. 2

**NOTE:** Installer is responsible for ensuring vehicle meets Federal, State, and Local standards and regulations.

## BODY STRENGTH

### ⚠ WARNING

Consult vehicle body manufacturer for vehicle body strength data. Make sure the forces created by the Liftgate are within the limits prescribed by the vehicle body manufacturer.

**NOTE:** Maximum operating bed height for C2 mounted on pickup body is 42" (Unloaded). Minimum bed height is 28" (Loaded).

The C2 is a body-mounted liftgate that put forces on the side walls of truck bodies (FIG. 4-1). For correct installation, truck bodies must be strong enough to withstand the tension, compression and shear forces shown in FIG. 4-1.

X= Tension on each sidewall

Y= Compression on each sidewall

Z= Shear on each sidewall

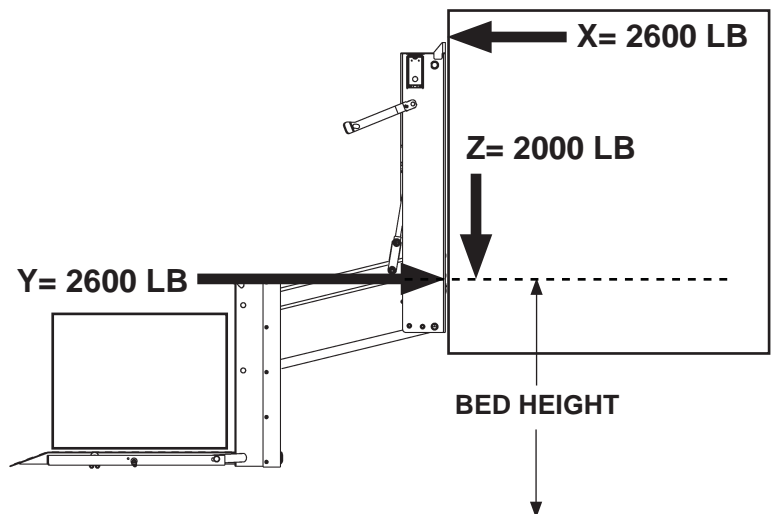

C2 LIFTGATE SHOWN ON TRUCK BODY  
FIG. 4-1

## PREPARING LIFTGATE

1. Remove mounting kits shipped with liftgate.  
Refer to **Sheets 1, 2 and 3**. Verify mounting brackets are the correct brackets for this installation.

### **! CAUTION**

Liftgate will not stand upright without the shipping angles. Before removing the angles, make sure Liftgate is supported with forklift or pallet jack. Injury & property damage could result if Liftgate falls over.

2. Support Liftgate on shipping pallet with forklift or pallet jack. Then, unbolt shipping angle from each column on the Liftgate (**FIG. 5-1**). Save shipping angles to use for lower mounting brackets.

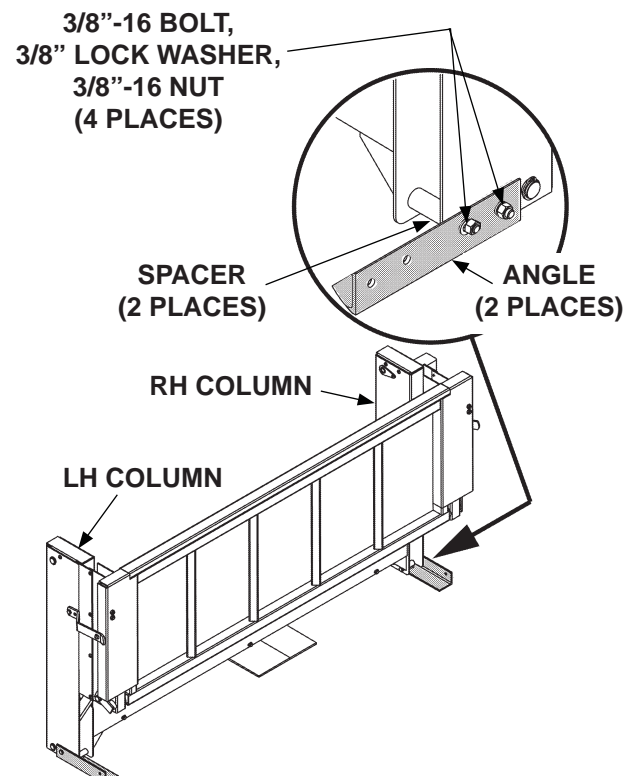

REMOVING SHIPPING ANGLES BOLTED  
TO COLUMNS OF C2 LIFTGATE  
FIG. 5-1

**BOLTING ON MAIN FRAME BRACKETS**

**NOTE:** The extra hole in the main frame mounting brackets is always below the 1/4" X 1" strip.

Bolt main frame mounting brackets (Kit items) to column flats (**FIGS. 6-1 and 6-2**).

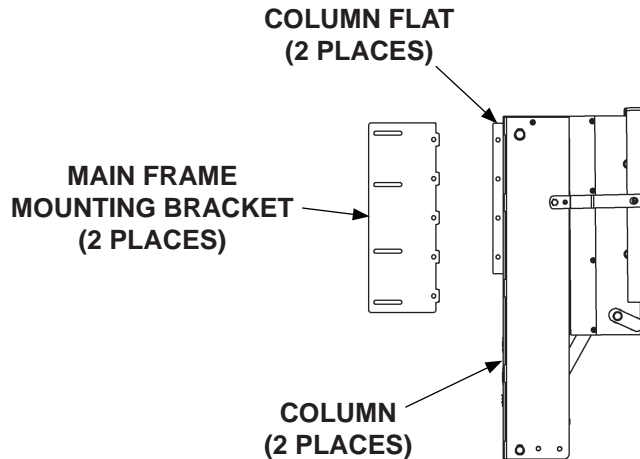

**C2 LIFTGATE SHOWN WITH BOLT-ON  
MAIN FRAME BRACKETS  
FIG. 6-1**

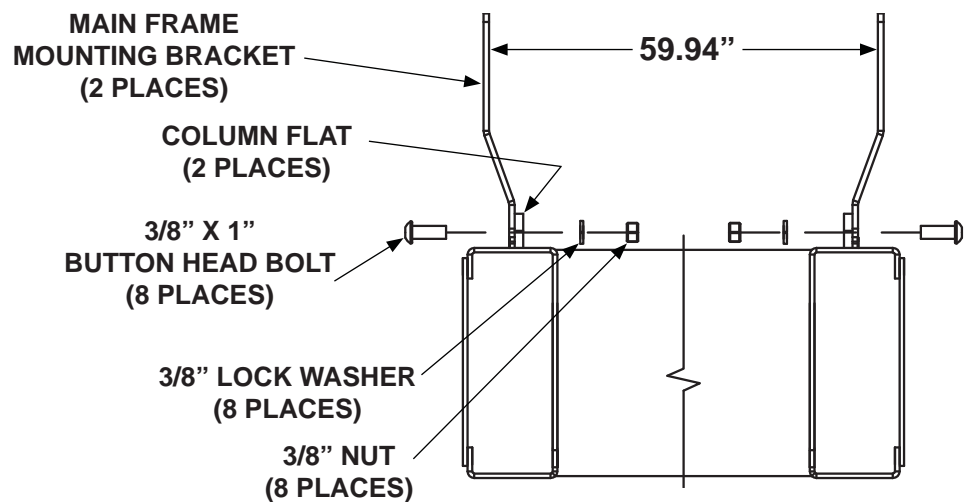

**BOLTING MAIN FRAME MOUNTING BRACKETS  
TO COLUMNS ON C2 LIFTGATE  
(TOP VIEW)  
FIG. 6-2**

## PREPARING PICKUP TRUCK

**NOTE:** If pickup is a 2004 or newer F-150, only remove tailgate and supports.

1. Unbolt the tailgate, supports, strikers and fasteners (**FIG. 7-1**).

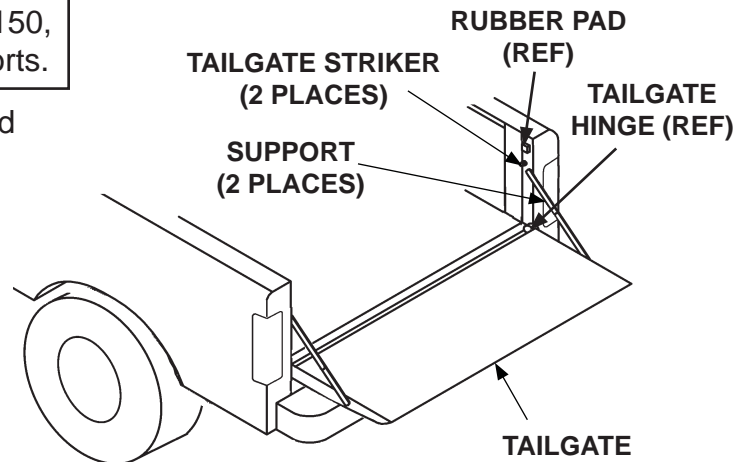

**REMOVING TAILGATE & SUPPORTS  
FIG. 7-1**

2. Support rear bumper and trailer hitch (if equipped) (**FIG. 7-2**) before unbolting bumper brackets and hitch (if equipped).

3. Remove trailer hitch (2004 or newer F-150) (**FIG. 7-2**).

**NOTE:** When liftgate is installed on the truck the tailgate, trailer hitch (if equipped), rear bumper, and bumper brackets cannot be reinstalled.

4. Unbolt and remove rear bumper and bumper brackets (**FIG. 7-2**).

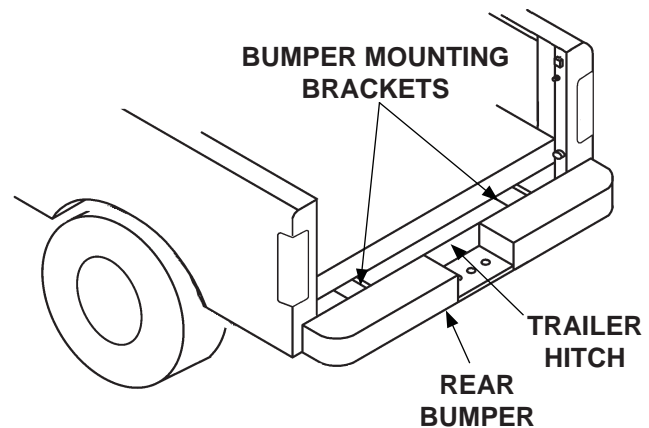

**REMOVING REAR BUMPER  
FIG. 7-2**

## CHANGING TAILLIGHT MOUNTING

**NOTE:** The following change in taillight mounting is not required for **2008 and newer F-150 pickups**. When taillight mounting is changed for **2007 and older F-150 pickups**, it must be completed before liftgate is installed so that taillight bulbs can be replaced without removing liftgate.

1. Remove 2 original taillight screws from RH taillight lens (**FIG. 8-1**). These screws are not needed after the taillight mounting is changed.
2. Drill a 9/64" hole through RH taillight lens and internal sheet metal (**FIG. 8-1**). Then, carefully drill a 3/16" hole through taillight lens to create clearance for the screw threads (**FIG. 8-1**).

**NOTE:** If liftgate is C2-15 model (1500 lb capacity), wait until liftgate is mounted on pickup bed before reinstalling taillights.

3. Apply clear automotive silicone sealant (**not supplied**) to the 3/16" hole in the taillight lens, and on the threaded portion of the self-tapping screw (**FIG. 8-1**).
4. Insert a self-tapping screw (Kit item) into 9/64" hole to secure the taillight lenses in place (**FIG 8-1**). Do not over-tighten screw.
5. Repeat steps 1 through 4 for LH taillight lens.

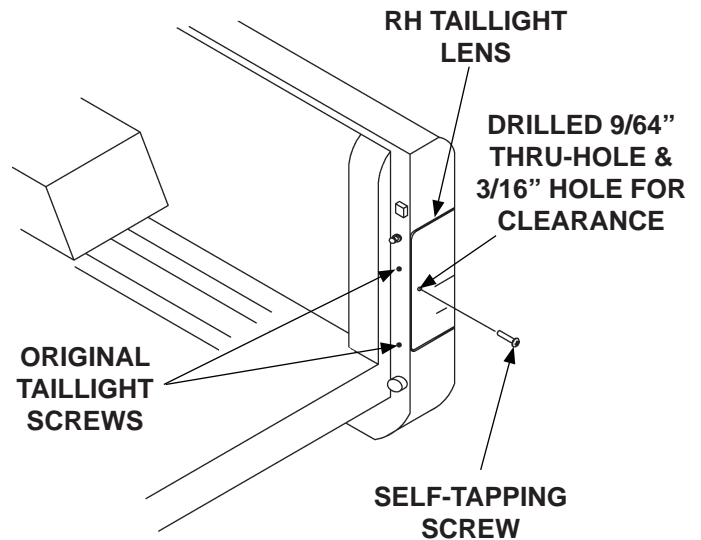

**MODIFYING TAILLIGHT MOUNTING  
FIG. 8-1**



**INSTALLING FILLER STRIP (IF NECESSARY)**

**⚠ WARNING**

Recommended practices for welding on steel parts are contained in the current AWS (American Welding Society) D1.1 Structural Welding Code - Steel. Damage to Liftgate and/or vehicle, and personal injury can result from welds that are done incorrectly.

**NOTE:** If pickup truck is equipped with after-market hitch, weld filler strip to main frame housing. It will fill gap between liftgate and pickup bed.

1. Arrange the filler strips (Kit item) end-to-end as shown in **FIG. 9-1**.

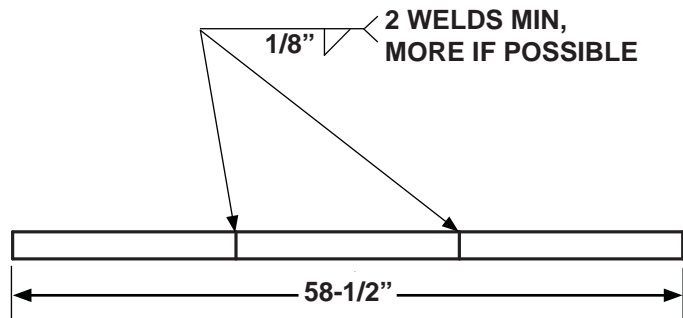

**FILLER STRIPS LAYOUT & WELDING**  
**FIG. 9-1**

**CAUTION**

To prevent damage, liftgate bat-power cables are disconnected before using electrical welder. Put welder ground lead as close as possible to part being welded. Use protective cover on liftgate and truck body to protect from welding heat and spatter.

2. Butt the ends of the 3 filler strips together to make one long strip (**FIG. 9-1**). Then, weld the 3 strips together as shown in **FIG. 9-1**.

**NOTE:** Position filler strips with the welds facing down.

3. Position and support liftgate between the corner posts of pickup bed (**FIG. 9-2**). Next, position filler strip flush with top-rear edge of main frame housing. Then, weld filler strip to main frame (**FIG. 9-2**). When the welds are cool, filler strip can be painted.

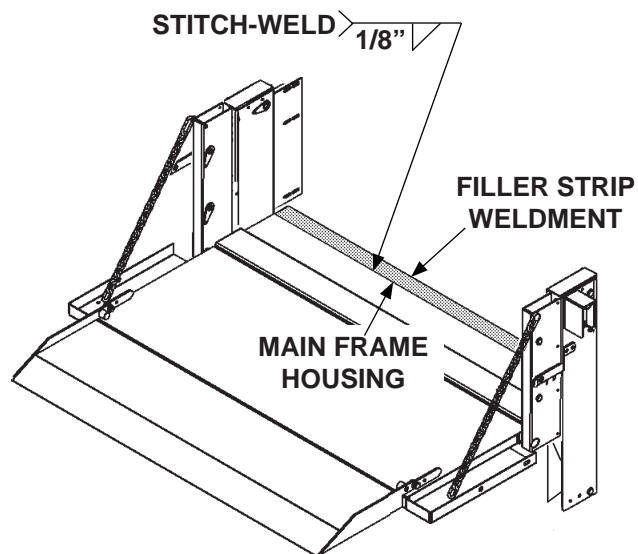

**POSITIONING & WELDING FILLER STRIP**  
**FIG. 9-2**

## INSTALLING LIFTGATE

**NOTE:** Holes for mounting brackets are marked and drilled only after liftgate is in correct position on the pickup bed.

**NOTE:** To avoid interference, install aftermarket hitch receiver before liftgate.

1. Position the LH and RH mounting brackets (Kit items) in the pickup bed just forward of corner posts (**FIG. 10-1**).
2. Position liftgate in the rear opening of the pickup bed (**FIG. 10-1**).
  - Liftgate centered on rear opening in pickup bed
  - Columns vertical
  - Spare tire access hole aligned with spare tire tube on truck
  - Top of main frame flush with floor of pickup bed

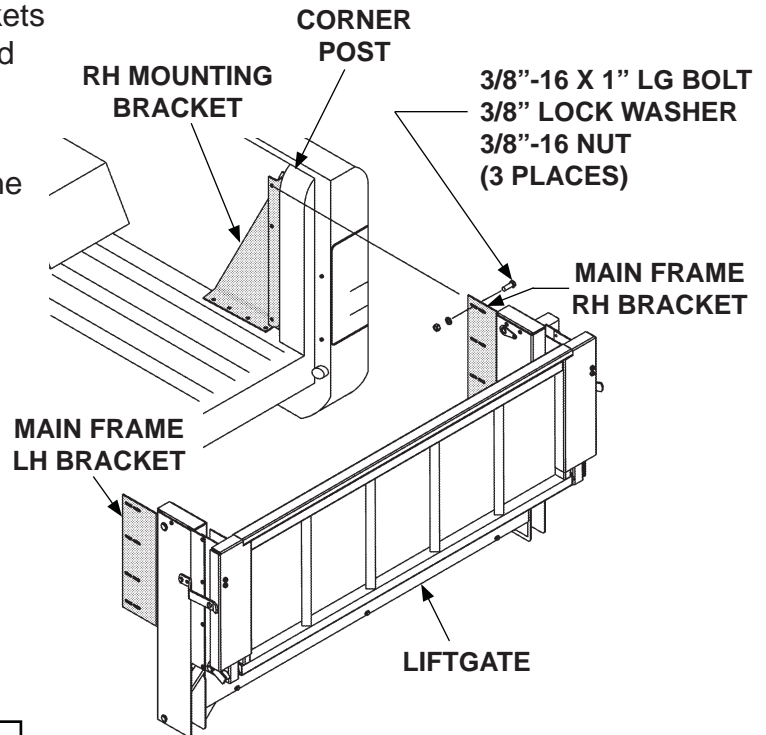

**BOLTING LIFTGATE TO RH MOUNTING BRACKET  
FIG. 10-1**

**NOTE:** Ensure nuts and lock washers are on the inboard side of the mounting brackets.

3. Bolt the main frame brackets on liftgate, to the RH mounting brackets as shown in **FIG. 10-1**. Handtighten bolts and nuts. Repeat for LH mounting bracket.
4. Allow the Liftgate to hang supported by the corner posts.

**INSTALLING LIFTGATE - Continued**

**CAUTION**

**Before drilling holes in the pickup bed, ensure there are no obstructions or items that could be damaged.**

5. Hold RH mounting bracket against corner post of the pickup bed (FIG. 11-1). Then, use 2 of the 4 bracket holes that are not obstructed, to drill 2 holes for 3/8"-16 bolts in floor of the pickup bed (FIG. 11-1). Repeat for LH mounting bracket.
6. Bolt RH mounting bracket to the floor of pickup bed as shown in FIG. 11-1. Repeat for LH mounting bracket.
7. Unlatch and unfold platform. Refer to **C2 Operation Manual** if needed. Then, adjust liftgate position so platform is level from front to back.
8. Securely tighten 3 bolts fastening RH mounting bracket to main frame bracket (FIG. 11-1). Ensure the split lock washers are not in the slotted holes on main frame bracket. Repeat for LH mounting bracket.

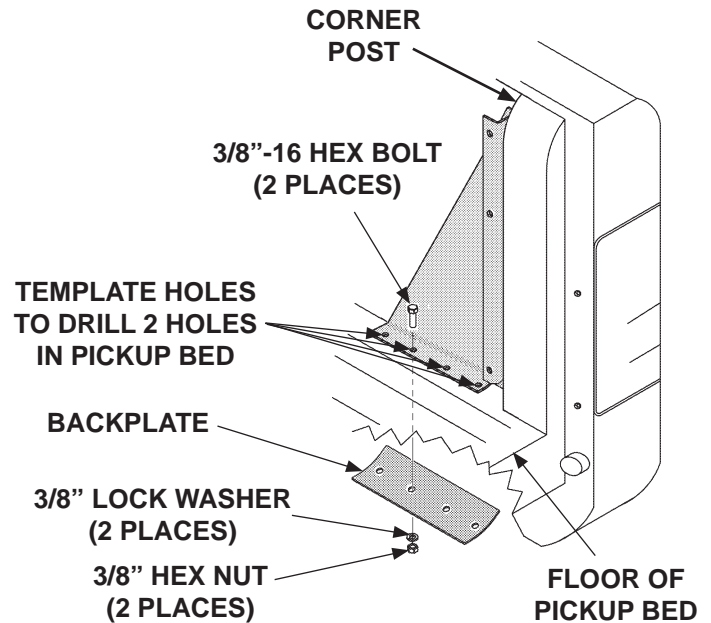

**BOLTING RH MOUNTING BRACKET TO PICKUP BED (LIFTGATE NOT SHOWN)  
FIG. 11-1**

**CAUTION**

**1500 lb capacity liftgates require additional support for the mounting brackets. Bolt bracket to pickup bed as shown in the illustration.**

9. Use upper 3/8" hole in the RH mounting plate as a template to drill hole through RH corner post of pickup bed (FIG. 11-2). Then, bolt RH mounting plate to corner post as shown in FIG. 11-2. Repeat for LH mounting plate.
10. If liftgate is C2-15 model (1500 lb capacity), go back and finish the steps for changing the mounting of taillight lenses.

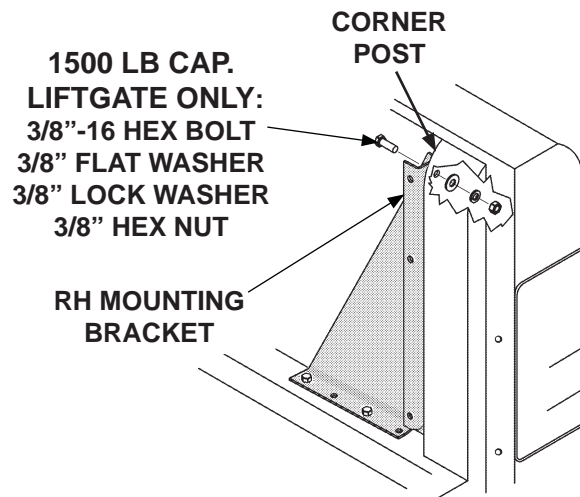

**FASTENING BRACKET TO INNER BOX (RIGHT SIDE SHOWN)  
FIG. 11-2**

**CHECKING ACCESS TO SPARE TIRE**

**CAUTION**

**Do not use a battery charger for connecting power to Liftgate power cables.**

1. Connect power from a 12 volt truck battery to the Liftgate power cables extending from the back of main frame housing.
2. Refer to operating instructions, in **C2 Operation Manual**, to unfold platform and activate the Liftgate.

**NOTE:** With the **POWER ON** and **LIFTGATE ACTIVATED** lights on, the Liftgate can be raised or lowered. If the Liftgate is not used for 90 seconds, the control will automatically deactivate.

3. Use the control switch to lower (**DN**) the platform to the ground (**FIG. 12-1**).
4. Unbolt and remove cover from main frame housing (**FIG. 12-2**).

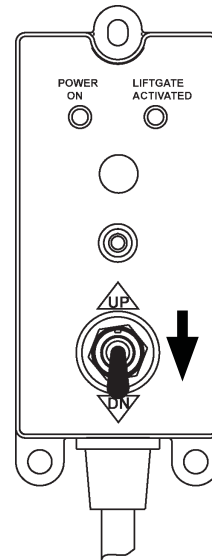

**USING CONTROL SWITCH TO LOWER LIFTGATE**  
**FIG. 12-1**

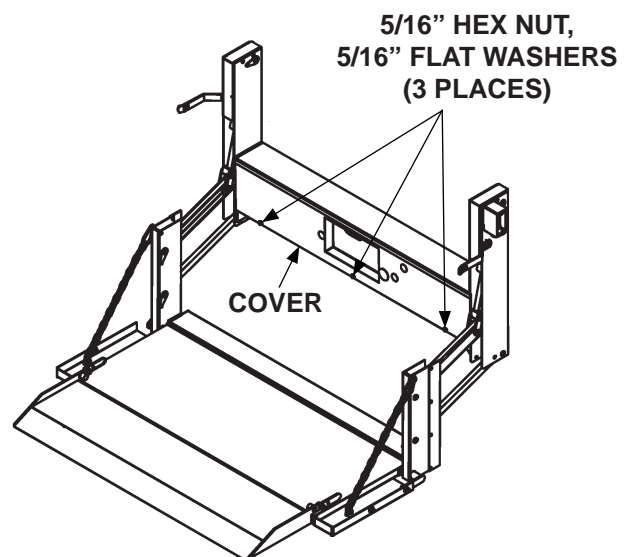

**REMOVING HOUSING COVER FROM C2 LIFTGATE**  
**FIG. 12-2**

**CHECKING ACCESS TO SPARE TIRE - Continued**

5. Remove the correct black plastic plugs from the cover and main frame (FIGS. 13-1 or 13-2).

LH COLUMN  
(DRIVER SIDE)

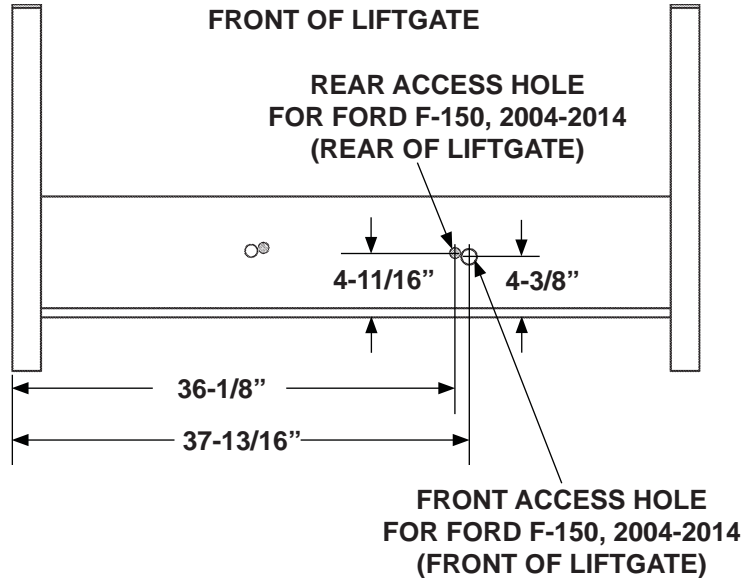

**REMOVING PLASTIC PLUGS FOR SPARE TIRE ACCESS, FORD F-150 (LIGHT DUTY), 2004-2014**  
FIG. 13-1

6. Insert the spare tire crank handle through the holes in the liftgate main frame.

LH COLUMN  
(DRIVER SIDE)

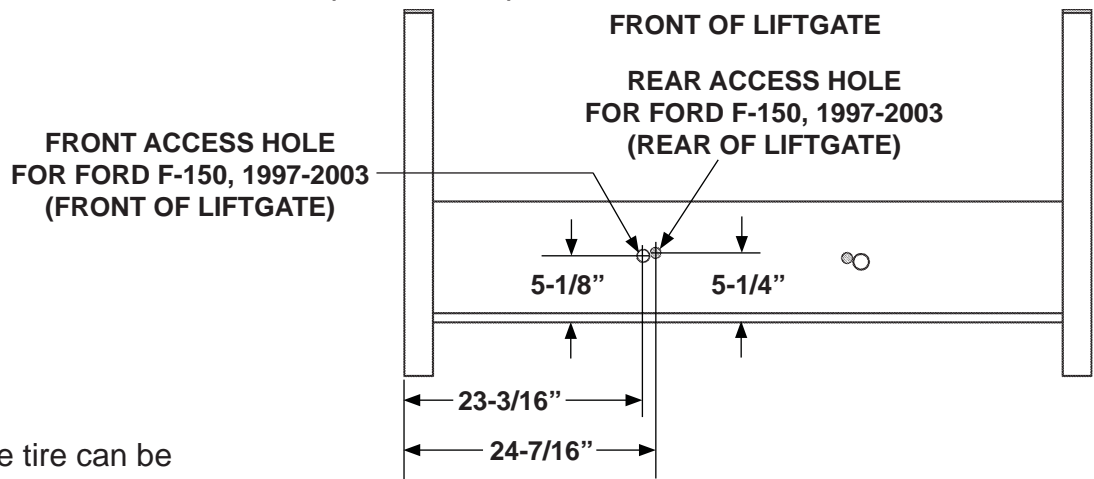

7. Ensure spare tire can be accessed using the crank handle.

**REMOVING PLASTIC PLUGS FOR SPARE TIRE ACCESS, FORD F-150 (LIGHT DUTY), 1997-2003**  
FIG. 13-2

### ROUTING POWER CABLES

1. Remove the small parts and manual kit from the housing. Refer to **Sheet 3** for contents of the kits.
2. Install circuit breaker (**FIG. 14-1**) inside the engine compartment near truck battery (+) terminal and away from moving parts. Allow enough room for power cables to be run and for easy access to circuit breaker.

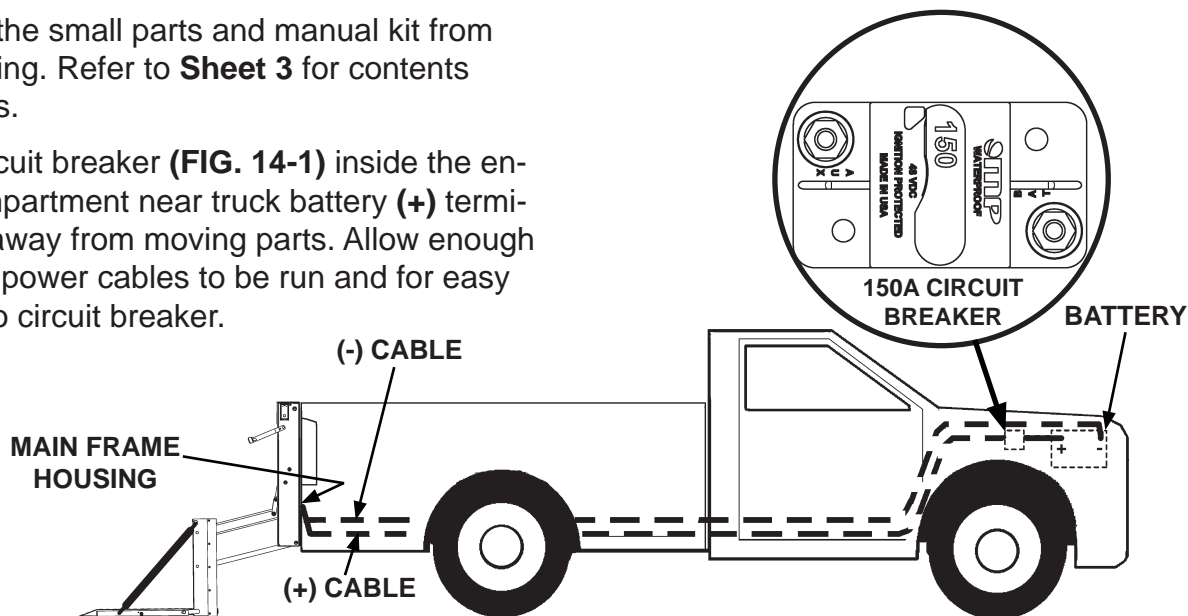

**RUNNING POWER CABLES FROM LIFTGATE TO BATTERY**  
**FIG. 14-1**

3. Pull the (+) and (-) power cables through the cord grip on back of main frame housing. Leave about 2" of slack, for power cables, inside main frame housing.
4. Route power cables along truck frame to truck battery (**FIG. 14-1**). Pull extra cable beyond the battery terminals. Then, separate positive (+) cable from negative (-) cable.
5. Cut positive (+) cable to the length required to reach the **AUX** terminal of the circuit breaker (**FIG. 14-1**), without putting strain on the connection. Install copper lug (Kit item) (**FIGS. 14-2 and 14-3**). Then, connect to **AUX** terminal on 150A circuit breaker.

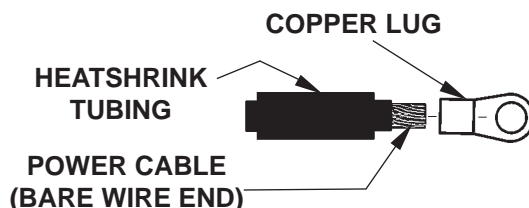

**PLACING COPPER LUG & HEATSHRINK TUBING ON POWER CABLE**  
**FIG. 14-2**

6. Cut remaining positive (+) cable long enough to reach from the circuit breaker **BAT** terminal to the positive (+) battery terminal (**FIG. 14-1**) without putting strain on the connection. Install copper lugs (Kit item) on both ends of cable (**FIGS. 14-2 and 14-3**). Then, connect cable to **BAT** terminal on 150A circuit breaker and positive (+) terminal on battery.



**TYPICAL POWER CABLE WITH COPPER LUG INSTALLED**  
**FIG. 14-3**

7. Cut negative (-) cable to length required to reach negative (-) battery terminal without putting strain on the connection. Install copper lug (Kit item) (**FIGS. 14-2 and 14-3**). Then, connect cable to negative (-) terminal on battery.

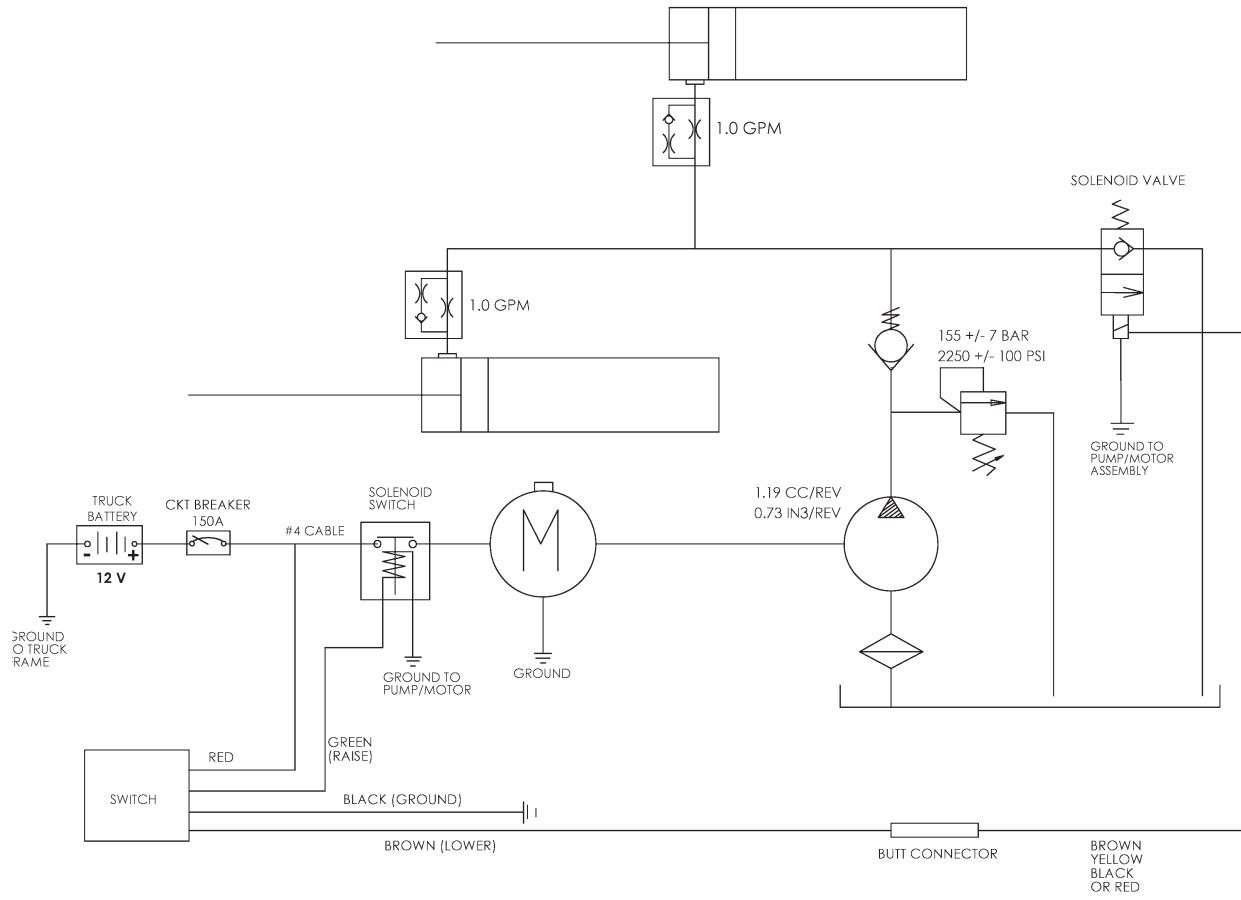

**C2 PICKUP LIFTGATE HYDRAULIC & ELECTRICAL SYSTEMS DIAGRAM**  
**FIG. 15-1**

**INSTALL LOWER MOUNTS**

**CAUTION**

Liftgate can be severely damaged by connecting electric welder to liftgate at the wrong place. To prevent damage, always connect ground lead directly to component being welded & as close as possible to weld.

**NOTE:** Lower mounts are essential for Liftgate to be installed correctly. They attach to the truck frame and support the bottom of Liftgate.

1. Unbolt bracket plates from bottom of main frame housing (**FIG. 16-1**).
2. Position 2 bolt-on mounting angles, nearest to truck frame at bottom of Liftgate main frame housing (**FIG. 16-2**). Then bolt each angle to hole allowing closest fit to truck frame.
3. Position 2 bracket plates (Kit items) on truck frame at bottom of Liftgate main frame housing (**FIG. 16-2**). Bolt to truck frame. If necessary, modify bracket plates for best fit.
4. Clamp 2 short angles (no holes) (Kit items) to bracket plates on truck frame (**FIG. 16-2**). Position the 2 angles to reach the angles bolted on bottom of main frame housing.
5. With angles, and bracket plates positioned and clamped together, tack weld the angles and plates in position (**FIG. 16-2**).
6. Unbolt tack-welded lower brackets from truck frame (**FIG. 16-2**). Then, finish weld the bracket plates and angles.
7. Bolt the finish-welded bracket plates and angles back in position on the bottom of the main frame housing and truck frame (**FIG. 16-2**).

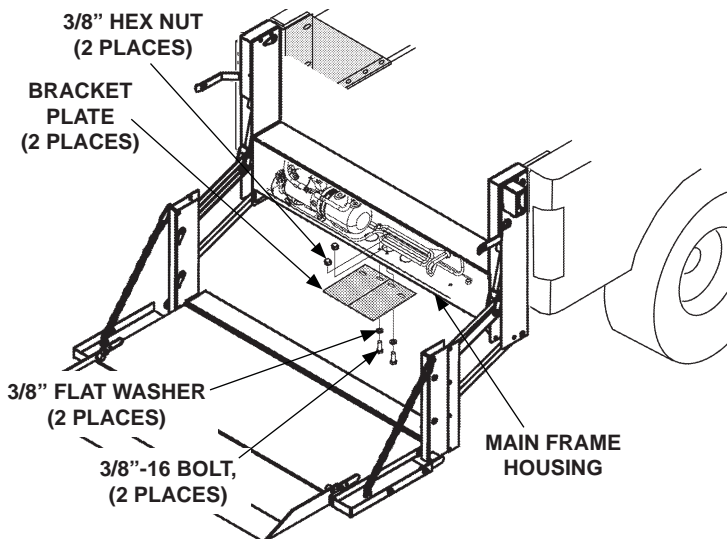

**REMOVING BRACKET PLATES FROM MAIN FRAME HOUSING (C2 SHOWN)**  
**FIG. 16-1**

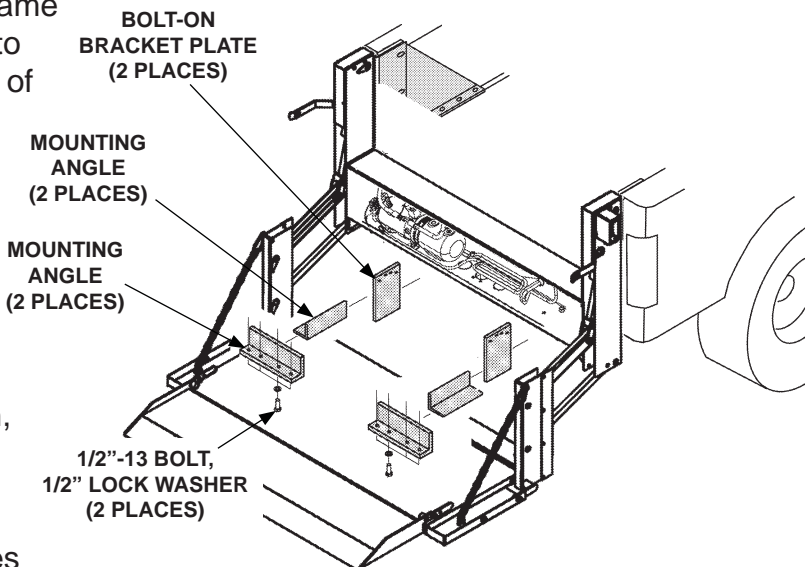

**FABRICATING LOWER BRACKETS TO SUPPORT LIFTGATE (C2 SHOWN)**  
**FIG. 16-2**



## COMPLETE LIFTGATE INSTALLATION

### CAUTION

Hydraulic system is filled at the factory with correct amount of oil. It is unnecessary to add more oil except as required for periodic maintenance of the liftgate.

1. Remove the solid plug from the pump reservoir (**FIG. 17-1**). Install breather plug (Kit item) in pump reservoir.

2. Bolt on main frame cover (**FIG. 17-2**).

3. Install the two square plastic grommet nuts (Kit item), for the license plate, into the square holes on the Liftgate main frame cover (**FIG. 17-2**).

4. Install the license plate using two 1/4"-20 self-tapping screws (Kit item) (**FIG. 17-2**).

5. Install the license plate lights into the holes provided. Refer to instruction sheet **M-14-35**. Then, connect the license plate lights to the vehicle's wiring.

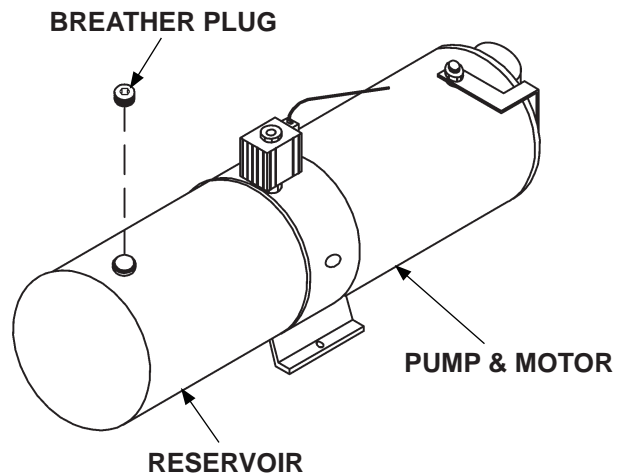

INSTALLING VENT PLUG ON  
PUMP RESERVOIR  
FIG. 17-1

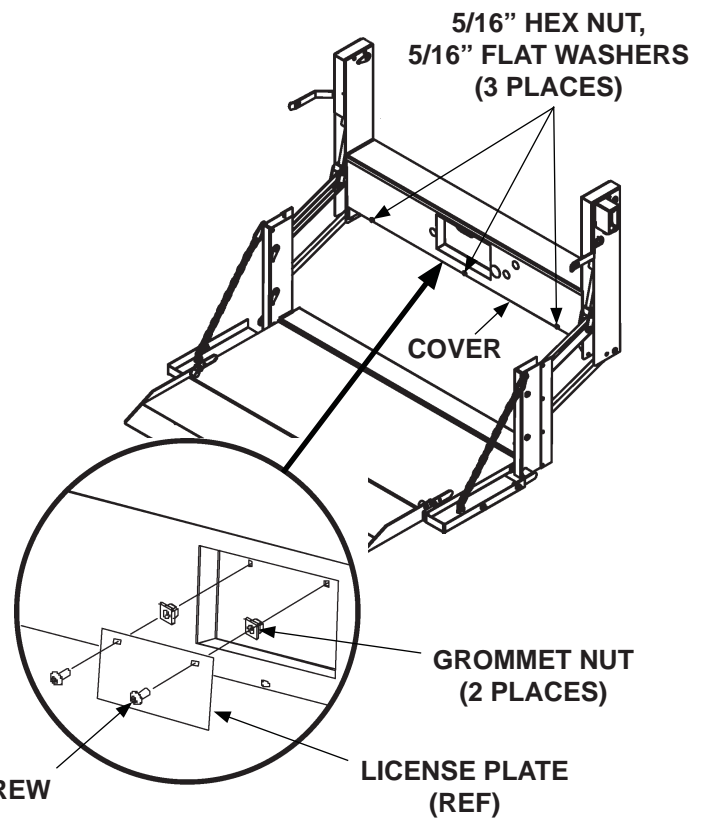

INSTALLING COVER & LICENSE PLATE  
(C2 LIFTGATE SHOWN)  
FIG. 17-2

## COMPLETE LIFTGATE INSTALLATION - Continued

6. To use the drop-away platform feature, install drop pin and 3/8"-16 lock nut (Kit items) on the bottom of RH column (FIG. 18-1). Tighten lock nut securely.

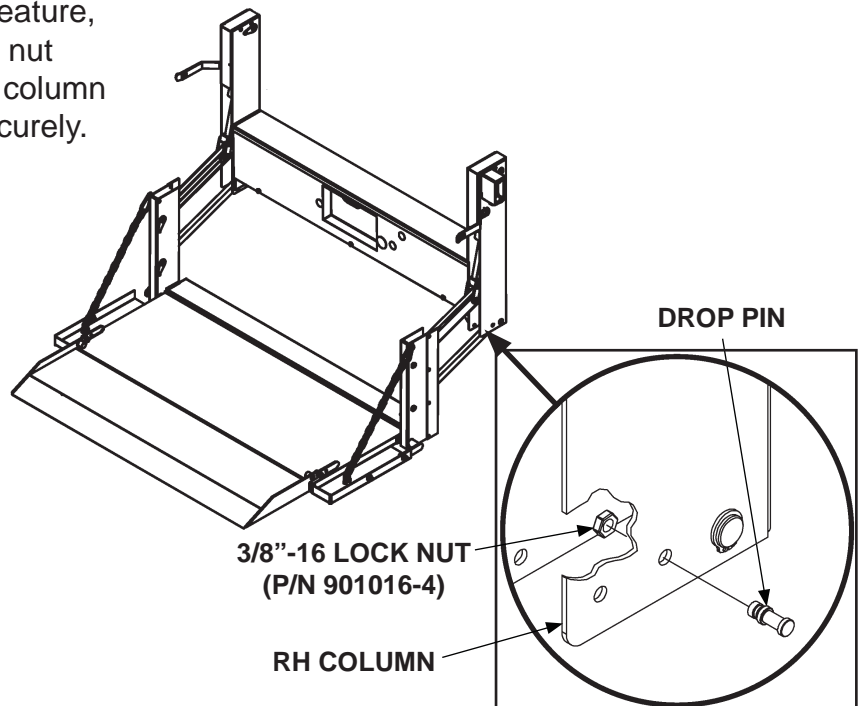

**INSTALLING DROP PIN ON  
RH COLUMN (C2 LIFTGATE SHOWN)  
FIG. 18-1**

7. Install the 3/8" round plastic plugs into the empty holes in the bottom of the columns.
8. If previously removed, reinstall spare tire.

**TEST OPERATION OF LIFTGATE**

**! WARNING**

**Keep all foreign objects out of the Liftgate mainframe and away from pinch points at all times when operating Liftgate.**

**NOTE:** The **LIFTGATE ACTIVATED** LED illuminates when Liftgate power is on. Control switch should deactivate after 90 seconds of not being used.

1. Check operation of control switch for proper operation by pressing **POWER ON** button once to activate. Next, press **POWER ON** button again to deactivate Liftgate power. Then, press the **POWER ON** button twice to reset low voltage (**FIG. 19-1**).
2. Press the **LIFTGATE ACTIVATED** switch within 1 second to activate the timer (**FIG. 19-1**).
3. Raise (**UP**) and lower (**DN**) the unloaded platform (**FIGS. 19-1** and **19-2**) on a flat surface. Check for proper operating speed and alignment with the ground.
4. Load the platform with the rated capacity and measure the time to **RAISE** the platform (**FIG. 19-1**). The platform should raise approximately 2" to 3" per second.
5. Examine the platform for any downward creep.
6. Measure the time to **LOWER** the platform still loaded (**FIG. 19-2**). The load should descend approximately 7" to 9" per second.
7. Remove the load from the platform and examine the Liftgate and vehicle for hydraulic oil leaks, loose wiring, and any other problems.
8. Reinstall the main frame housing cover. Then, close and latch platform.

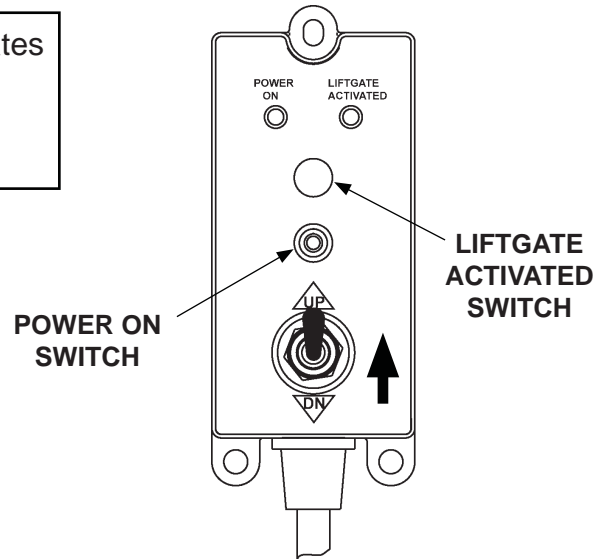

**CHECKING OPERATION OF CONTROL SWITCH AND RAISING PLATFORM**  
**FIG. 19-1**

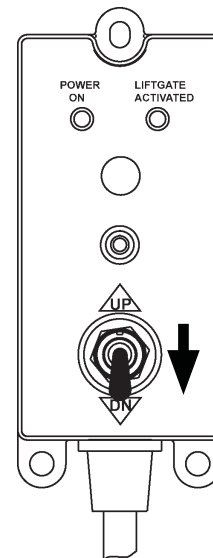

**USING CONTROL SWITCH TO LOWER PLATFORM**  
**FIG. 19-2**

**TEST OPERATION OF LIFTGATE - Continued**

9. Lock the latch on LH side or RH side through the hole in the latch pin (**FIG. 20-1**).

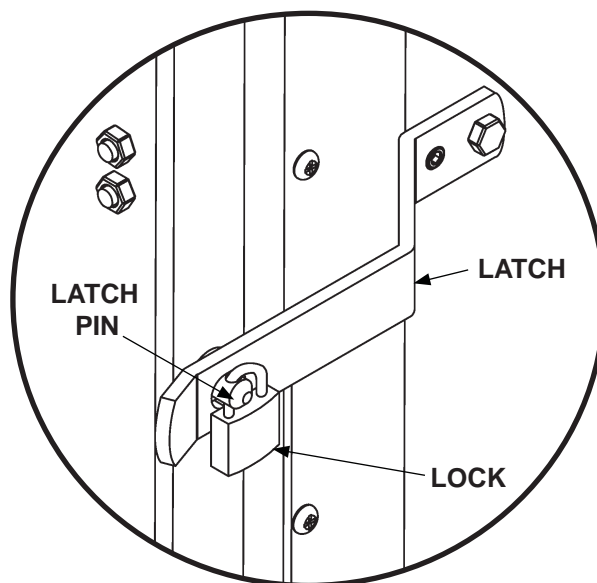

**LOCKING PLATFORM  
(C2 LIFTGATE)  
FIG. 20-1**