

M-08-04
REV. A
AUGUST 2010

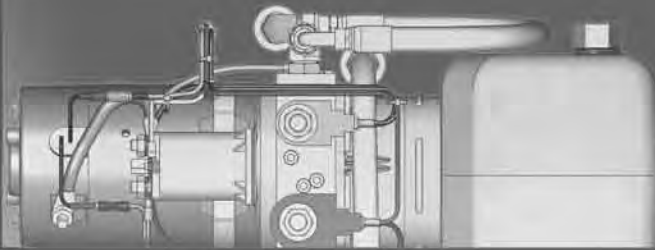

MAXON[®]
GPT

MAINTENANCE MANUAL
GPT-25, GPT-3, GPT-4 & GPT-5



MAXON[®]

LIFT CORP.

11921 Slauson Ave.
Santa Fe Springs, CA. 90670

CUSTOMER SERVICE:

TELEPHONE (562) 464-0099 TOLL FREE (800) 227-4116

FAX: (888) 771-7713

NOTE: For latest version of all Manuals (and replacements), download the Manuals from Maxon's website at www.maxonlift.com.

WARRANTY/ RMA POLICY & PROCEDURE

LIFTGATE WARRANTY

Type of Warranty: Full Parts and Labor

Term of Warranty: Standard Liftgates - 2 years from ship date or 6,000 cycles
Premium Liftgates - 2 years from ship date or 10,000 cycles

This warranty shall not apply unless the product is installed, operated and maintained in accordance with MAXON Lift's specifications as set forth in MAXON Lift's Installation, Operation and Maintenance manuals. This warranty does not cover normal wear, maintenance or adjustments, damage or malfunction caused by improper handling, installation, abuse, misuse, negligence, or carelessness of operation. In addition, this warranty does not cover equipment that has had unauthorized modifications or alterations made to the product.

MAXON agrees to replace any components which are found to be defective during the first 2 years of service, and will reimburse for labor based on MAXON's Liftgate Warranty Flat Rate Schedule. (Copy of the Flat Rate is available at www.maxonlift.com.)

All warranty repairs must be performed by an authorized MAXON warranty facility. For any repairs that may exceed \$500, including parts and labor, MAXON's Technical Service Department must be notified and an "Authorization Number" obtained.

All claims for warranty must be received within 30 Days of the repair date, and include the following information:

1. Liftgate Model Number and Serial Number
2. The End User must be referenced on the claim
3. Detailed Description of Problem
4. Corrective Action Taken, and Date of Repair
5. Parts used for Repair, Including MAXON Part Number(s)
6. MAXON R.M.A. # and/or Authorization # if applicable (see below)
7. Person contacted at MAXON if applicable
8. Claim must show detailed information i.e. Labor rate and hours of work performed

Warranty claims can also be placed online at www.maxonlift.com. Online claims will be given priority processing.

All claims for warranty will be denied if paperwork has not been received or claim submitted via Maxon website for processing by MAXON's Warranty Department within 30 days of repair date.

All components may be subject to return for inspection, prior to the claim being processed. MAXON products may not be returned without prior written approval from MAXON's Technical Service Department. Returns must be accompanied by a copy of the original invoice or reference with original invoice number and are subject to a credit deduction to cover handling charges and any necessary reconditioning costs. **Unauthorized returns will be refused and will become the responsibility of the returnee.**

Any goods being returned to MAXON Lift must be pre-approved for return, and have the R.M.A. number written on the outside of the package in plain view, and returned freight prepaid. All returns are subject to a 15% handling charge if not accompanied by a detailed packing list. Returned parts are subject to no credit and returned back to the customer. Defective parts requested for return must be returned within 30 days of the claim date for consideration to:

MAXON Lift Corp.
10321 Greenleaf Ave., Santa Fe Springs, CA 90670
Attn: RMA# _____

MAXON's warranty policy does not include the reimbursement for travel time, towing, vehicle rental, service calls, oil, batteries or loss of income due to downtime. Fabrication or use of non Maxon parts, which are available from MAXON, are also not covered.

MAXON's Flat Rate Labor Schedule takes into consideration the time required for diagnosis of a problem.

All Liftgates returned are subject to inspection and a 15% restocking fee. Any returned Liftgates or components that have been installed or not returned in new condition will be subject to an additional reworking charge, which will be based upon the labor and material cost required to return the Liftgate or component to new condition.

PURCHASE PART WARRANTY

Term of Warranty: 1 Year from Date of Purchase.

Type of Warranty: Part replacement only. MAXON will guarantee all returned genuine MAXON replacement parts upon receipt and inspection of parts and original invoice.

All warranty replacements parts will be sent out via ground freight. If a rush shipment is requested, all freight charges will be billed to the requesting party.

TABLE OF CONTENTS

| | |
|--|-----------|
| WARNINGS | 6 |
| SAFETY INSTRUCTIONS | 6 |
| LIFTGATE TERMINOLOGY | 9 |
| PERIODIC MAINTENANCE | 10 |
| PERIODIC MAINTENANCE CHECKS..... | 10 |
| PERIODIC MAINTENANCE CHECKLIST..... | 11 |
| CHECKING HYDRAULIC FLUID | 12 |
| CHANGING HYDRAULIC FLUID..... | 14 |
| REPLACING PLATFORM TORSION SPRING | 16 |
| PLATFORM ADJUSTMENT | 17 |
| PARTS BREAKDOWN | 19 |
| MAIN ASSEMBLY (ALUMINUM PLATFORM)..... | 19 |
| MAIN FRAME ASSEMBLY: GPT-25 & GPT-3..... | 20 |
| MAIN FRAME ASSEMBLY: GPT-4 & GPT-5..... | 24 |
| PLATFORM & FLIPOVER ASSEMBLY (ALUMINUM)..... | 28 |
| PLATFORM & FLIPOVER ASSEMBLY WITH CART STOPS (ALUMINUM)..... | 29 |
| PLATFORM ASSEMBLY (ALUMINUM)..... | 30 |
| FLIPOVER WITH SINGLE CART STOP (ALUMINUM) | 32 |
| FLIPOVER WITH DUAL CART STOPS (ALUMINUM)..... | 34 |
| DOCK BUMPER..... | 36 |
| PUMP ASSEMBLY | 37 |
| HYDRAULIC COMPONENTS - POWER DOWN..... | 38 |
| 12 VDC POWER UNIT | 40 |
| CONTROL SWITCH AND POWER CABLE | 43 |

| | |
|--|-----------|
| DECALS | 44 |
| SYSTEM DIAGRAMS | 47 |
| PUMP & MOTOR SOLENOID OPERATION | 47 |
| HYDRAULIC SCHEMATIC (POWER DOWN) | 48 |
| ELECTRICAL SCHEMATIC (POWER DOWN) | 49 |
| TROUBLESHOOTING | 50 |
| PLATFORM WILL NOT RAISE & MOTOR WILL NOT RUN | 50 |
| PLATFORM WILL NOT RAISE, BUT MOTOR RUNS | 51 |
| PLATFORM RAISES BUT LEAKS DOWN..... | 52 |
| PLATFORM RAISES PARTIALLY AND STOPS..... | 54 |
| LIFTGATE WILL NOT LIFT RATED CAPACITY | 55 |
| PLATFORM RAISES SLOWLY | 56 |
| PLATFORM WILL NOT LOWER, LOWERS TOO SLOWLY OR TOO QUICKLY..... | 58 |
| PLATFORM WILL NOT TILT DOWN TO THE GROUND | 60 |

Comply with the following **WARNINGS** and **SAFETY INSTRUCTIONS** while maintaining Liftgates. See Operation Manual for operating safety requirements.

⚠ WARNING

- Do not stand, or allow obstructions, under the platform when lowering the Liftgate. **Be sure your feet are clear of the Liftgate.**
- **Keep fingers, hands, arms, legs, and feet clear of moving Liftgate parts (and platform edges) when operating the Liftgate.**
- **Correctly stow platform when not in use. Extended platforms could create a hazard for people and vehicles passing by.**
- **Disconnect Liftgate power cable from battery** before repairing or servicing Liftgate.
- If it is necessary to stand on the platform while maintaining the Liftgate, keep your feet and any objects clear of the inboard edge of the platform. Your feet or objects on the platform can become trapped between the platform and the Liftgate extension plate.
- Recommended practices for welding on steel parts are contained in the current **AWS (American Welding Society) D1.1 Structural Welding Code - Steel**. Damage to Liftgate and/or vehicle, and personal injury could result from welds that are done incorrectly.
- Recommended practices for welding on aluminum parts are contained in the current **AWS (American Welding Society) D2.1 Structural Welding Code - Aluminum**. Damage to Liftgate and/or vehicle, and personal injury could result from welds that are done incorrectly.

SAFETY INSTRUCTIONS

- Read and understand the instructions in this **Maintenance Manual** before performing maintenance on the Liftgate.
- Before operating the Liftgate, read and understand the operating instructions in **Operation Manual**.
- Comply with all **WARNING** and instruction decals attached to the Liftgate.
- Keep decals clean and legible. If decals are illegible or missing, replace them. Free replacement decals are available from **Maxon Customer Service**.
- Consider the safety and location of bystanders and location of nearby objects when operating the Liftgate. Stand to one side of the platform while operating the Liftgate
- Do not allow untrained persons to operate the Liftgate.
- Wear appropriate safety equipment such as protective eyeglasses, faceshield and clothing while performing maintenance on the Liftgate and handling the battery. Debris from drilling and contact with battery acid may injure unprotected eyes and skin.
- Be careful working by an automotive type battery. Make sure the work area is well ventilated and there are no flames or sparks near the battery. Never lay objects on the battery that can short the terminals together. If battery acid gets in your eyes, immediately seek first aid. If acid gets on your skin, immediately wash it off with soap and water.

MAXON[®]

11921 Slauson Ave. Santa Fe Springs, CA. 90670 (800) 227-4116 FAX (888) 771-7713

- If an emergency situation arises (vehicle or Liftgate) while operating the Liftgate, release the control switch to stop the Liftgate.
- A correctly installed Liftgate operates smoothly and reasonably quiet. The only noticeable noise during operation comes from the power unit while the platform is raised. Listen for scraping, grating and binding noises and correct the problem before continuing to operate Liftgate.
- Use only **Maxon Authorized Parts** for replacement parts. Provide Liftgate model and serial number information with your parts order. Order replacement parts from:

MAXON LIFT CORP. Customer Service
11921 Slauson Ave., Santa Fe Springs, CA 90670

Online: www.maxonlift.com

Express Parts Ordering: Phone (800) 227-4116 ext. 4345

Email: Ask your Customer Service representative

THIS PAGE INTENTIONALLY LEFT BLANK

MAXON[®]

11921 Slauson Ave. Santa Fe Springs, CA. 90670 (800) 227-4116 FAX (888) 771-7713

LIFTGATE TERMINOLOGY

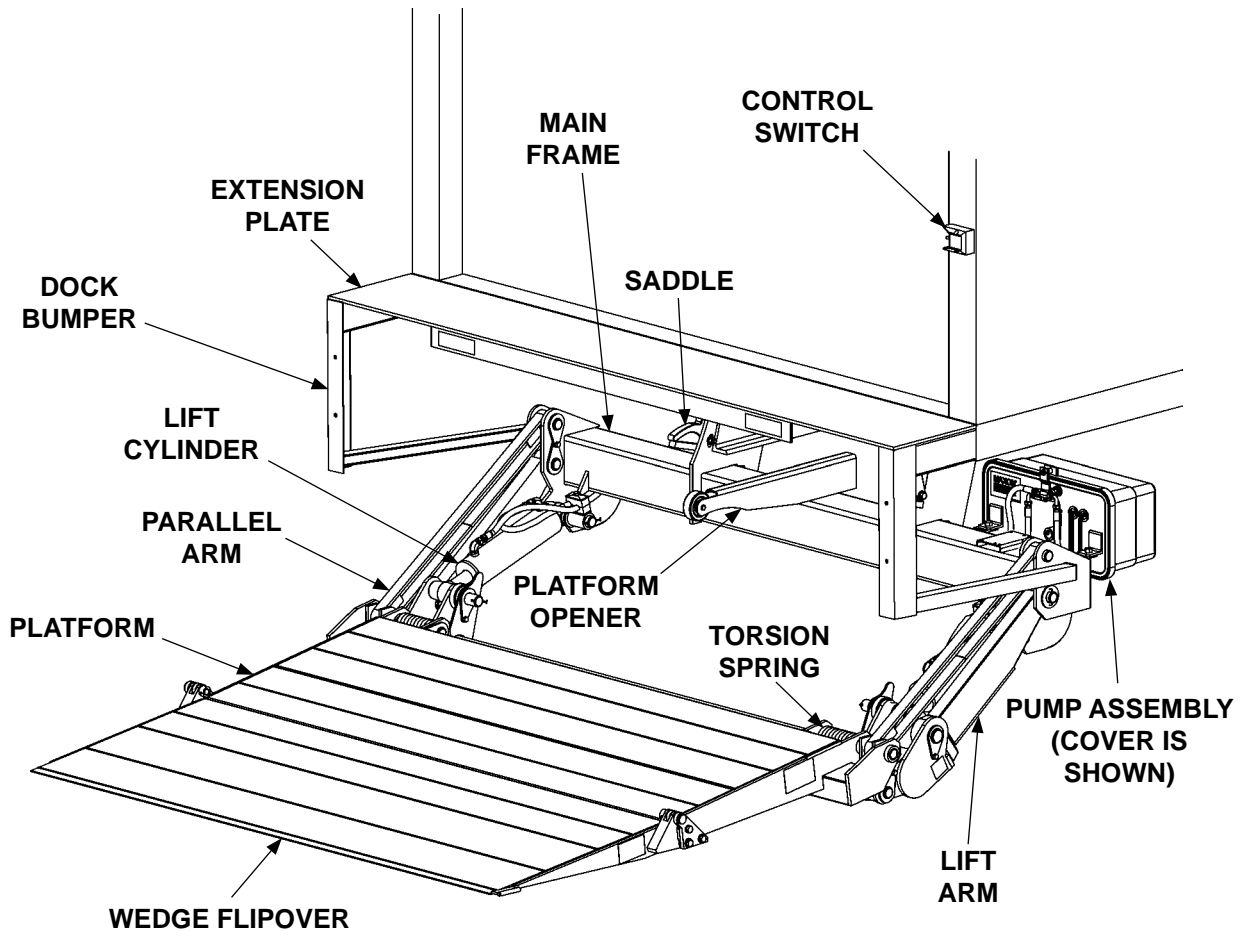

PERIODIC MAINTENANCE PERIODIC MAINTENANCE CHECKS

⚠ WARNING

Never operate the Liftgate if parts are loose or missing.

NOTE: Make sure vehicle is parked on level ground while performing the maintenance checks.

Quarterly or 1250 Cycles (whichever occurs first)

Check the hydraulic fluid level in the pump reservoir. Refer to the **CHECKING HYDRAULIC FLUID** procedure in the **PERIODIC MAINTENANCE** section.

If hydraulic fluid appears contaminated, refer to the **CHANGING HYDRAULIC FLUID** procedure in the **PERIODIC MAINTENANCE** section.

Keep track of the grade of hydraulic fluid in the pump reservoir and never mix two different grades of fluid.

Check all hoses and fittings for chafing and fluid leaks. Tighten loose fittings or replace parts as required.

Check electrical wiring for chafing and make sure wiring connections are tight and free of corrosion. Use dielectric grease to protect electrical connections.

Check that all **WARNING and instruction decals** are in place. Also, make sure decals are legible, clean and undamaged.

Check that all bolts, nuts, and roll pins are in place. Make sure roll pins protrude evenly from both sides of hinge pin collar. Replace fasteners and roll pins if necessary.

CAUTION

Damaged cylinder seals and contaminated hydraulic fluid can result from painting the polished portion of the cylinder rod. To prevent damage, protect the exposed polished portion of the cylinder rod while painting.

Check for rust and oily surfaces on Liftgate. If there is rust or oil on Liftgate, clean it off. Touch up the paint where bare metal is showing. MAXON recommends using the aluminum primer touchup paint kit, P/N 908119-01.

Semi-annually or 2500 Cycles (whichever occurs first)

Visually check the platform hinge pins for excessive wear and broken welds. See **PARTS BREAKDOWN** section for replacement parts. Also, do the **Quarterly or 1250 Cycles** maintenance checks.

MAXON[®]

11921 Slauson Ave. Santa Fe Springs, CA. 90670 (800) 227-4116 FAX (888) 771-7713

PERIODIC MAINTENANCE CHECKLIST

NOTE: Make sure vehicle is parked on level ground while performing maintenance checks.

Quarterly or 1250 Cycles (whichever occurs first)

- Check the level and condition of the hydraulic fluid.
- Visually check all hoses and fittings for chafing and fluid leaks. Tighten loose fittings or replace parts as required.
- Check electrical wiring for chafing and make sure wiring connections are tight and free of corrosion. Use dielectric grease to protect electrical connections.
- Check that all **WARNING and instruction decals** are in place. Also, make sure decals are legible, clean, and undamaged.
- Check that all bolts, nuts, and roll pins are in place. Make sure roll pins protrude evenly from both sides of hinge pin collar. Replace fasteners and roll pins if necessary.
- Check for rust and oily surfaces on Liftgate. If there is rust or oil on Liftgate or if the Liftgate is dirty, clean it off. Touch up the paint where bare metal is showing. Refer to the paint system **CAUTION** and recommended touchup kit on the preceding page.

Semi-annually or 2500 Cycles (whichever occurs first)

- Visually check the platform hinge pins for excessive wear and broken welds.
- Do the **Quarterly or 1250 Cycles Checks** on this checklist.

PERIODIC MAINTENANCE CHECKING HYDRAULIC FLUID

CAUTION

Keep dirt, water and other contaminants from entering the hydraulic system. Before opening the hydraulic fluid reservoir filler cap, drain plug and hydraulic lines, clean up contaminants that can get in the openings. Also, protect the openings from accidental contamination.

NOTE: Use correct grade of hydraulic fluid for your location.

+50 to +120 Degrees F - Grade ISO 32

Below + 70 Degrees F - Grade ISO 15 or MIL-H-5606

See TABLES 13-1 & 13-2 for recommended brands.

1. Unbolt and remove pump cover (FIG. 12-1).
2. Check the hydraulic fluid level in reservoir as follows. With Liftgate stowed, or platform at vehicle bed height, level should be as shown in FIG. 12-2.

NOTE: If the hydraulic fluid in the reservoir is contaminated, do the **CHANGING HYDRAULIC FLUID** procedure in this section.

3. If needed, add fluid to the reservoir as follows. Pull out (no threads) filler cap (FIG. 12-2). Fill the reservoir with hydraulic fluid until reservoir looks about half full (FIG. 12-2). Reinstall filler cap (FIG. 12-2).

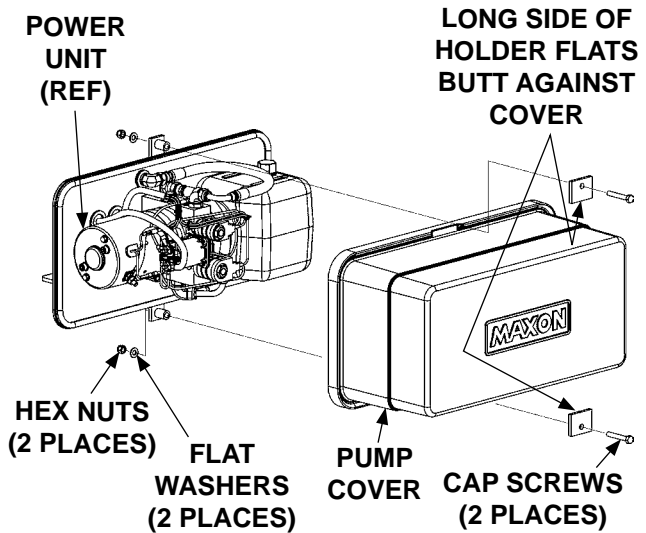

**UNBOLTING / BOLTING PUMP COVER
FIG. 12-1**

CAUTION

Pump cover must be correctly secured to prevent it from becoming a hazard. To secure pump cover, the long side of the holder flats must butt against pump cover as shown in the illustration.

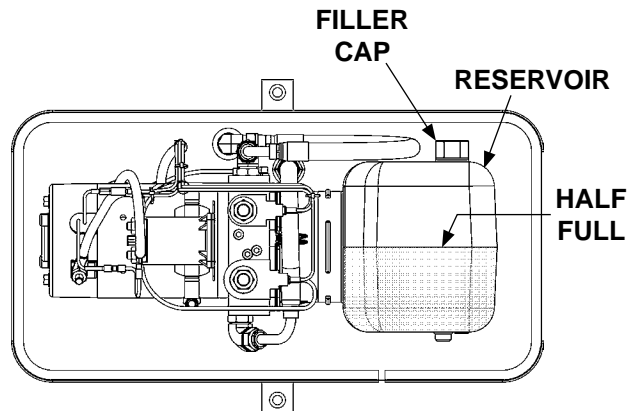

**POWER UNIT FLUID LEVEL
FIG. 12-2**

4. Bolt on the pump cover as shown in FIG. 12-1. Torque the 5/16"-18 cover bolts from 10 to 14 lbs.-ft.

| ISO 32 HYDRAULIC OIL | |
|----------------------|--------------------------------------|
| RECOMMENDED BRANDS | PART NUMBER |
| AMSOIL | AWH-05 |
| CHEVRON | HIPERSYN 32 |
| KENDALL | GOLDEN MV |
| SHELL | TELLUS S2 V32 |
| EXXON | UNIVIS N-32 |
| MOBIL | DTE-13M, DTE-24, HYDRAULIC OIL-13 |

TABLE 13-1

| ISO 15 OR MIL-H-5606 HYDRAULIC OIL | |
|------------------------------------|-------------------|
| RECOMMENDED BRANDS | PART NUMBER |
| AMSOIL | AWF-05 |
| CHEVRON | FLUID A, AW-MV-15 |
| KENDALL | GLACIAL BLU |
| SHELL | TELLUS S2 V15 |
| EXXON | UNIVIS HVI-13 |
| MOBIL | DTE-11M |
| ROSEMEAD | THS FLUID 17111 |

TABLE 13-2

PERIODIC MAINTENANCE CHANGING HYDRAULIC FLUID

CAUTION

Keep dirt, water and other contaminants from entering the hydraulic system. Before opening the hydraulic fluid reservoir filler cap, drain plug and hydraulic lines, clean up contaminants that can get in the openings. Also, protect the openings from accidental contamination.

NOTE: Use correct grade of hydraulic fluid for your location.

+50 to +120 Degrees F - Grade ISO 32

Below + 70 Degrees F - Grade ISO 15 or MIL-H-5606

See **TABLES 13-1 & 13-2** for recommended brands.

1. Unbolt and remove pump cover (FIG. 14-1). Place empty 5 gallon bucket under drain plug (FIG. 14-2).

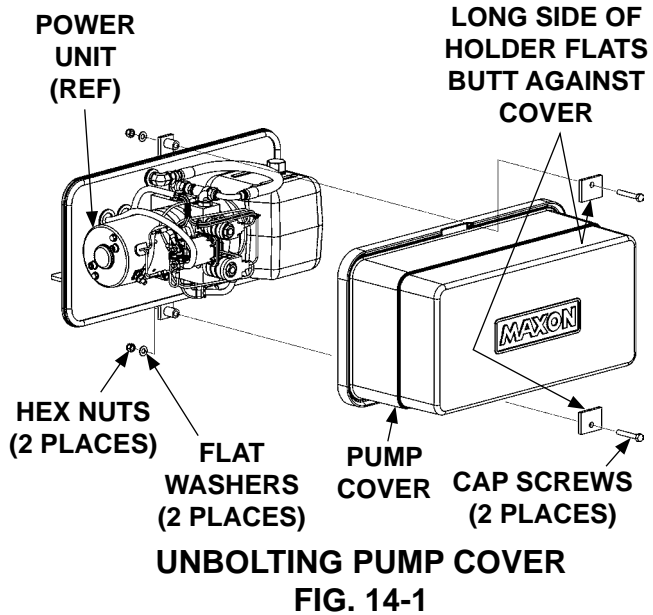

2. Open and raise platform to vehicle bed height. Pull out (no threads) drain plug (FIG. 14-2). Drain hydraulic fluid.

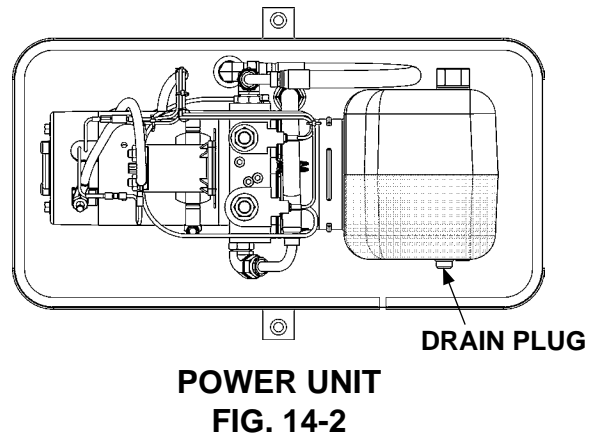

MAXON

11921 Slauson Ave. Santa Fe Springs, CA. 90670 (800) 227-4116 FAX (888) 771-7713

NOTE: MAXON recommends using dielectric grease on all electrical connections.

3. Disconnect the white wire (**FIG. 15-1**) from starter solenoid. Lower the platform while draining the remaining hydraulic fluid from system. Reinstall drain plug. Reconnect the white wire to starter solenoid.

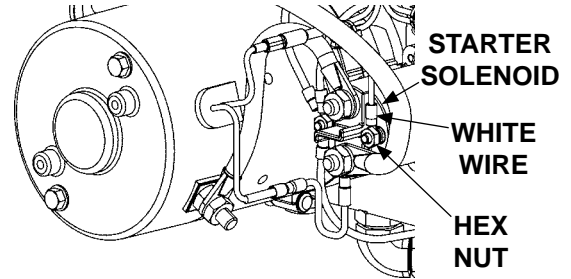

DISCONNECTING WHITE WIRE
FIG. 15-1

4. Pull out (no threads) filler cap (**FIG. 15-2**). Add 1 gallon of hydraulic fluid to reservoir. The reservoir should look about half full (**FIG. 15-2**). Reinstall filler cap (**FIG. 15-2**).

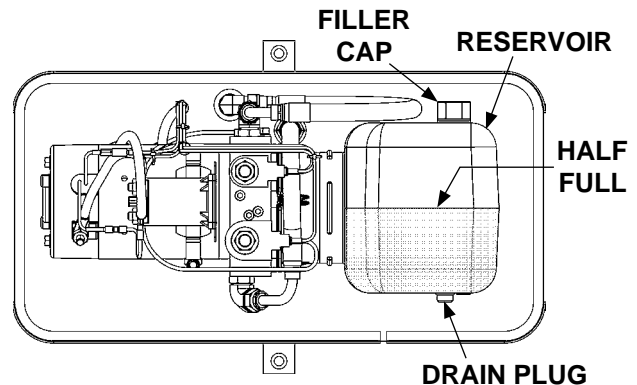

POWER UNIT
FIG. 15-2

5. Stow the Lift and do the **CHECKING HYDRAULIC FLUID** procedure in this section of the manual.

CAUTION

Pump cover must be correctly secured to prevent it from becoming a hazard. To secure pump cover, the long side of the holder flats must butt against pump cover as shown in the illustration.

6. Bolt on the pump cover as shown in **FIG. 15-3**. Torque the 5/16"-18 cover bolts from **10 to 14 lbs.-ft.**

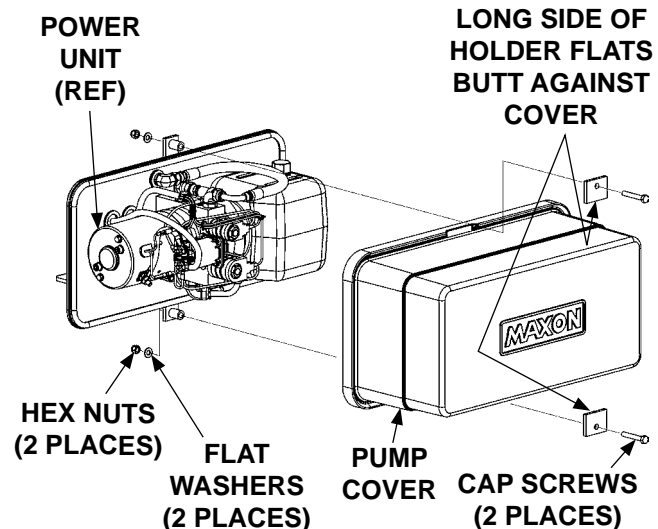

BOLTING ON PUMP COVER
FIG. 15-3

PERIODIC MAINTENANCE

REPLACING PLATFORM TORSION SPRING

NOTE: The following procedure shows how to replace torsion spring on RH side of platform. Use this procedure for replacing torsion spring on the LH side.

1. Manually fold flipover onto platform.
2. Raise platform to a convenient work height to gain access and release tension on the torsion spring.

⚠ CAUTION

To prevent injury and equipment damage, make sure there is no tension on torsion spring before removing hinge pin.

3. Unbolt hinge pin from hinge bracket (FIG. 16-1). Remove bolt and lock nut. Drive the hinge pin inboard toward the shackle with a hammer and pin punch, just enough to free the torsion spring (FIG. 16-1). Remove spring from shackle.

4. Install the torsion spring as shown in FIG. 16-2. Make sure the long leg of the spring is inserted in the bracket located on shackle (FIG. 16-2). Make sure the short end of the spring is visible and resting against the edge of the hinge bracket (FIG. 16-2).

5. Drive the hinge pin into correct position (FIG. 16-2) through the hinge bracket with a hammer and pin punch. Line up the bolt hole in the hinge pin with the hole in the hinge bracket. Bolt the hinge pin to hinge bracket with bolt and lock nut (FIG. 16-2).

6. Operate the Liftgate to make sure it operates correctly.

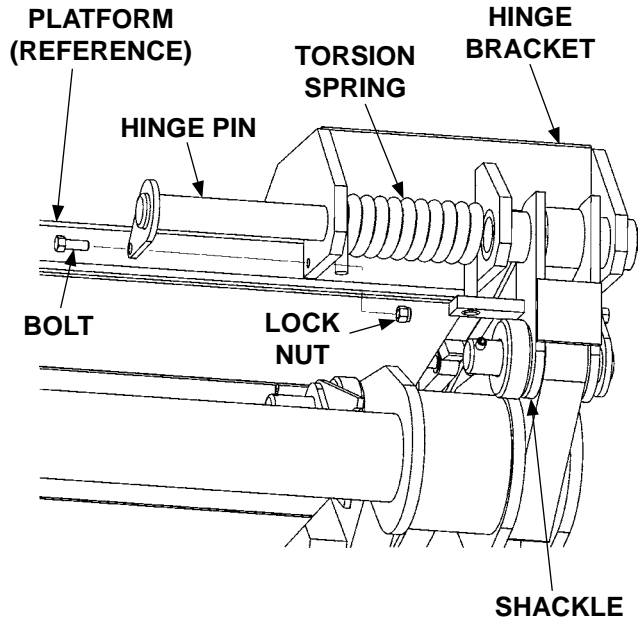

FIG. 16-1

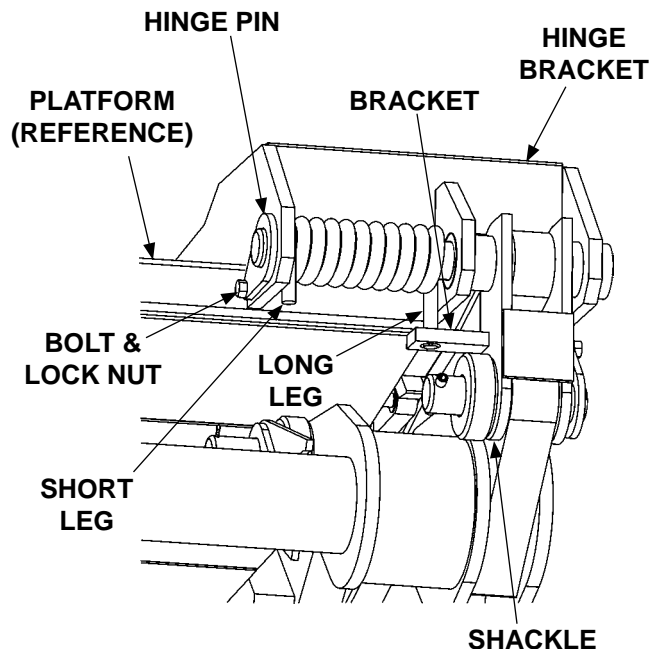
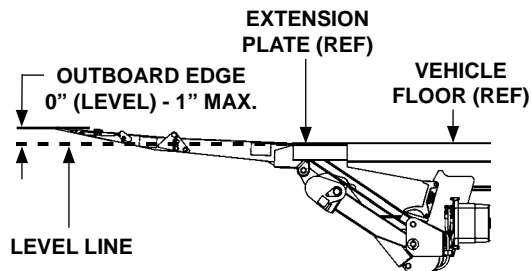

FIG. 16-2

PLATFORM ADJUSTMENT

NOTE: Before doing the following procedure, make sure vehicle is parked on level ground.

1. With the platform and flipover unfolded, raise platform to bed level (**FIG. 17-1**). Measure how much the outboard edge of platform rises above bed level (**FIG. 17-1**). The outboard edge must be level or a maximum of 1" above bed level (**FIG. 17-1**). If indication is correct, Liftgate is installed correctly and no adjustment is needed. If the outboard edge is below bed level, do instructions **2, 3, and 6**. If outboard edge is higher than 1", do instructions **4 through 6**.



PLATFORM EDGE AT OR ABOVE BED LEVEL
FIG. 17-1

2. Compare measurement "A" (**FIG. 17-2**) with the distances and shims in **TABLE 17-1**. For example: If measurement "A" (**FIG. 17-2**) is 1" below level and you want to raise outboard edge of platform 1" above level, use 1/8" shim to raise 2" (**TABLE 17-1**).

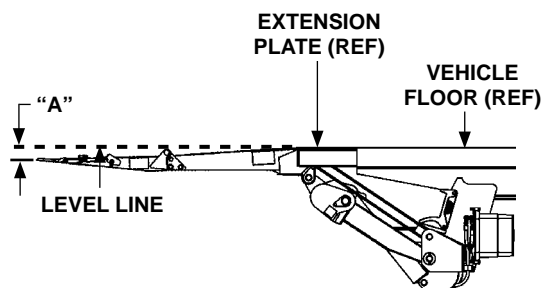

PLATFORM EDGE BELOW BED LEVEL
FIG. 17-2

| RAISE PLATFORM EDGE (OUTBOARD) THIS DISTANCE ("A") | REQUIRED SHIM THICKNESS | WELD SIZE "W" |
|--|-------------------------|---------------|
| 1" | 1/16" | 1/16" |
| 2" | 1/8" | 1/8" |
| 3" | 3/16" | 3/16" |
| 4" | 1/4" | 1/4" |

TABLE 17-1

3. Weld shims (parts bag item) on both platform stops (**FIG. 17-3**) to raise outboard edge of platform to correct position.

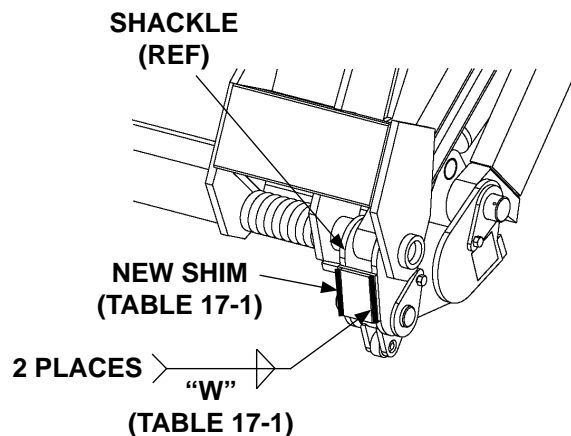

WELDING SHIMS (CURBSIDE SHOWN)
FIG. 17-3

PLATFORM ADJUSTMENT - Continued

4. Compare measurement “B” (FIG. 18-1) with the distances and grinding depths in TABLE 18-1. For example: If measurement “B” (FIG. 18-1) is 3” above bed level and you want to lower the outboard edge of platform to 1” above bed level, grind 1/8” from each platform stop (TABLE 18-1).

| LOWER PLATFORM EDGE (OUTBOARD) THIS DISTANCE (“B”) | GRIND METAL FROM PLATFORM STOP |
|--|--------------------------------|
| 1” | 1/16” |
| 2” | 1/8” |
| 3” | 3/16” |
| 4” | 1/4” |

TABLE 18-1

5. Grind metal from platform stops (FIG. 18-2) to lower outboard edge of platform to correct position.

6. Lower the platform, then raise it to bed level. The outboard edge of platform should be level or up to 1” maximum above bed level (FIG. 18-3).

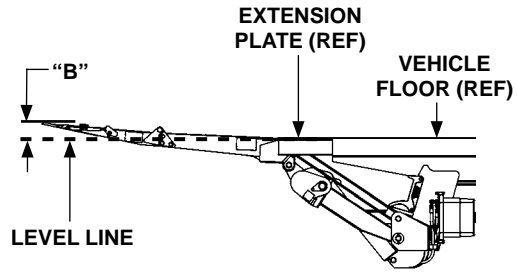

**PLATFORM EDGE ABOVE BED LEVEL
FIG. 18-1**

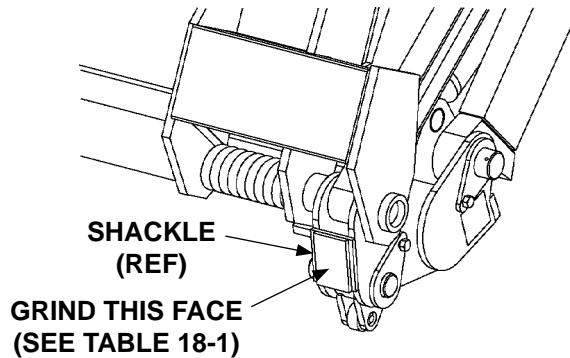

**GRINDING PLATFORM STOPS
(CURBSIDE SHOWN)
FIG. 18-2**

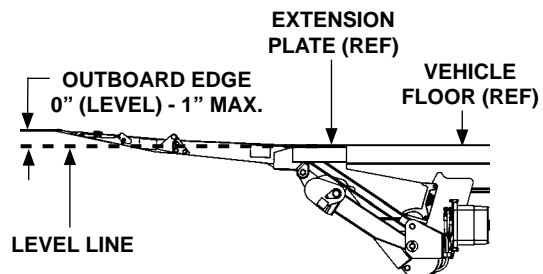

**PLATFORM EDGE ABOVE BED LEVEL
FIG. 18-3**

PARTS BREAKDOWN MAIN ASSEMBLY (ALUMINUM PLATFORM)

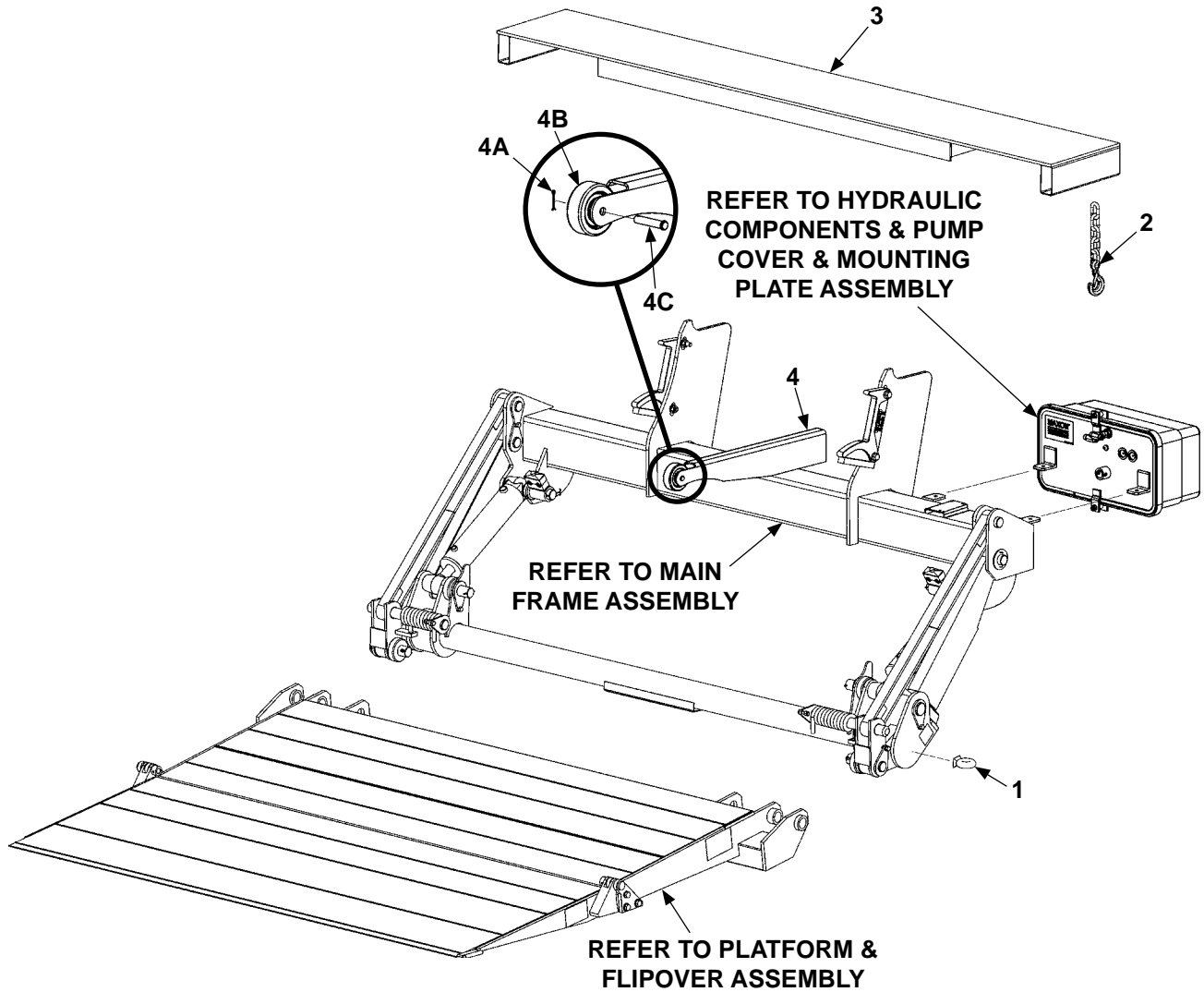

| ITEM | QTY. | PART NO. | DESCRIPTION |
|------|------|-----------|---------------------------|
| 1 | 1 | 226938 | PAD EYE, 3/4" X 1-1/2" |
| 2 | 1 | 227700 | HOOK ASSEMBLY |
| 3 | 1 | 226355 | EXTENSION PLATE |
| 4 | 1 | 265994-01 | OPENER ASSEMBLY |
| 4A | 1 | 030805 | COTTER PIN, 1/8" X 1" LG. |
| 4B | 1 | 280082-01 | ROLLER |
| 4C | 1 | 905202-03 | PIN |

MAIN FRAME ASSEMBLY: GPT-25 & GPT-3

MAXON

11921 Slauson Ave. Santa Fe Springs, CA. 90670 (800) 227-4116 FAX (888) 771-7713

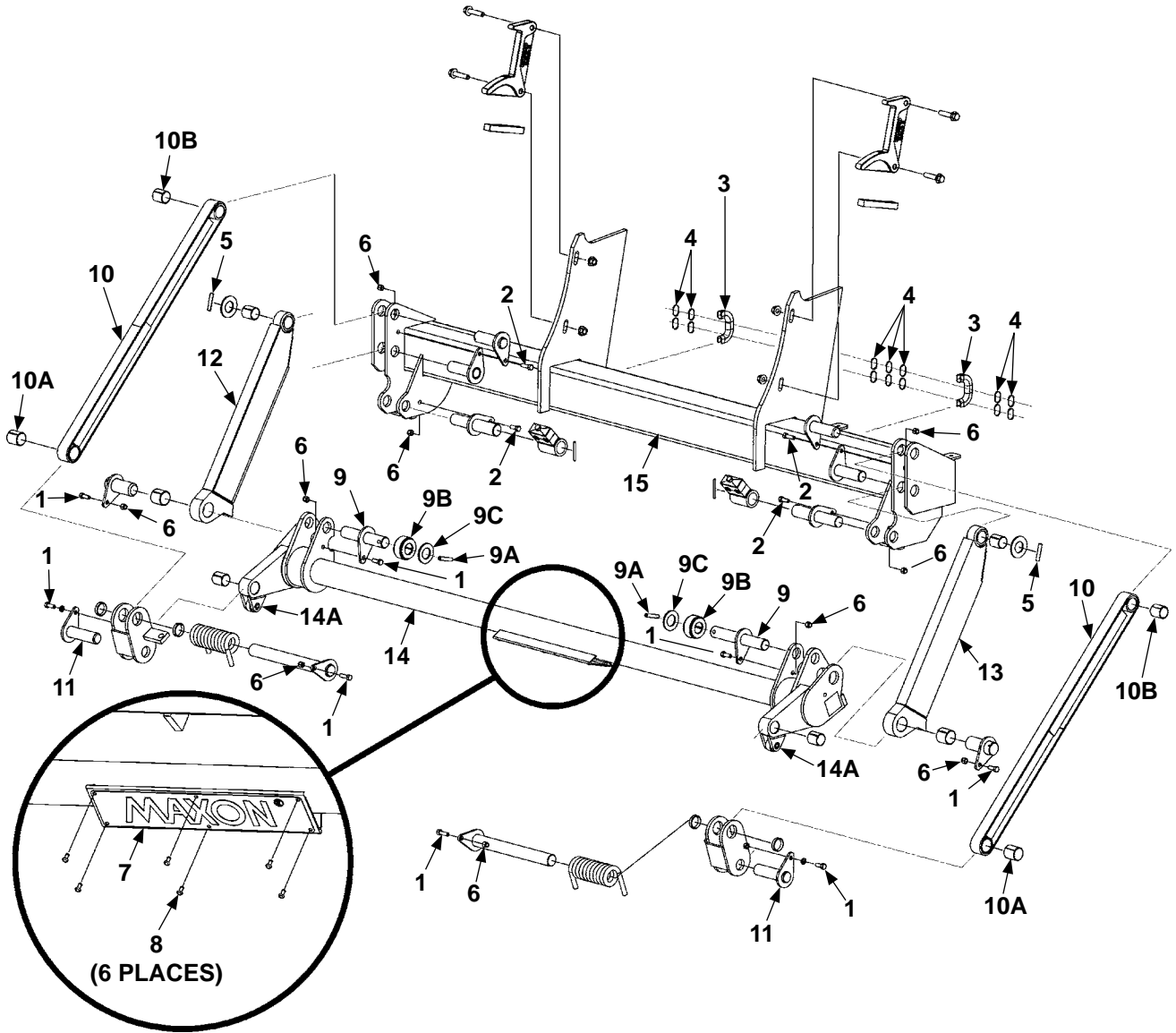

| ITEM | QTY. | PART NO. | DESCRIPTION |
|------|------|-----------|--|
| 1 | 8 | 030034 | BOLT, 3/8"-24 X 1" LG, GRADE 8 |
| 2 | 4 | 030035 | BOLT, 3/8"-24 X 1-1/4" LG, GRADE 8 |
| 3 | 2 | 040103-5 | SPLIT LOOM, 1/2" X 5" LG. |
| 4 | 14 | 205780 | PLASTIC TIE, 7" LG. |
| 5 | 2 | 221416 | ROLL PIN, 3/8" X 2" LG. |
| 6 | 10 | 226941 | LOCK NUT, 3/8"-24 |
| 7 | 1 | 050175 | MAXON PLATE, 3-1/4" X 15" LG. |
| 8 | 6 | 207644-01 | RIVET, 3/16" X .40" GRIP |
| 9 | 2 | 253085-01 | ROLLER PIN, ASSEMBLY |
| 9A | 1 | 221416 | ROLL PIN, 3/8" X 2" LG. |
| 9B | 1 | 261793-01 | ROLLER |
| 9C | 1 | 264272 | FLAT WASHER, 1-1/4" I.D. X 2-1/4" O.D. |
| 10 | 2 | 261788-01 | PARALLEL ARM |
| 10A | 2 | 905112-04 | BEARING, SELF LUBE 1-3/8" X 1-5/8" LG. |
| 10B | 2 | 905114-04 | BEARING, SELF LUBE 1-1/4" X 1-1/2" LG. |
| 11 | 2 | 282390-01 | PIN WELDMENT |
| 12 | 1 | 262322-01 | LIFT ARM WELDMENT, LH |
| 13 | 1 | 262322-02 | LIFT ARM WELDMENT, RH |
| 14 | 1 | 262396 | LIFT FRAME WELDMENT |
| 14A | 2 | 263473 | ROLLER, KNUCKLE DOWN |
| 15 | 1 | 282462-01 | MAIN FRAME |

MAIN FRAME ASSEMBLY: GPT-25 & GPT-3 - Continued

MAXON®

11921 Slauson Ave. Santa Fe Springs, CA. 90670 (800) 227-4116 FAX (888) 771-7713

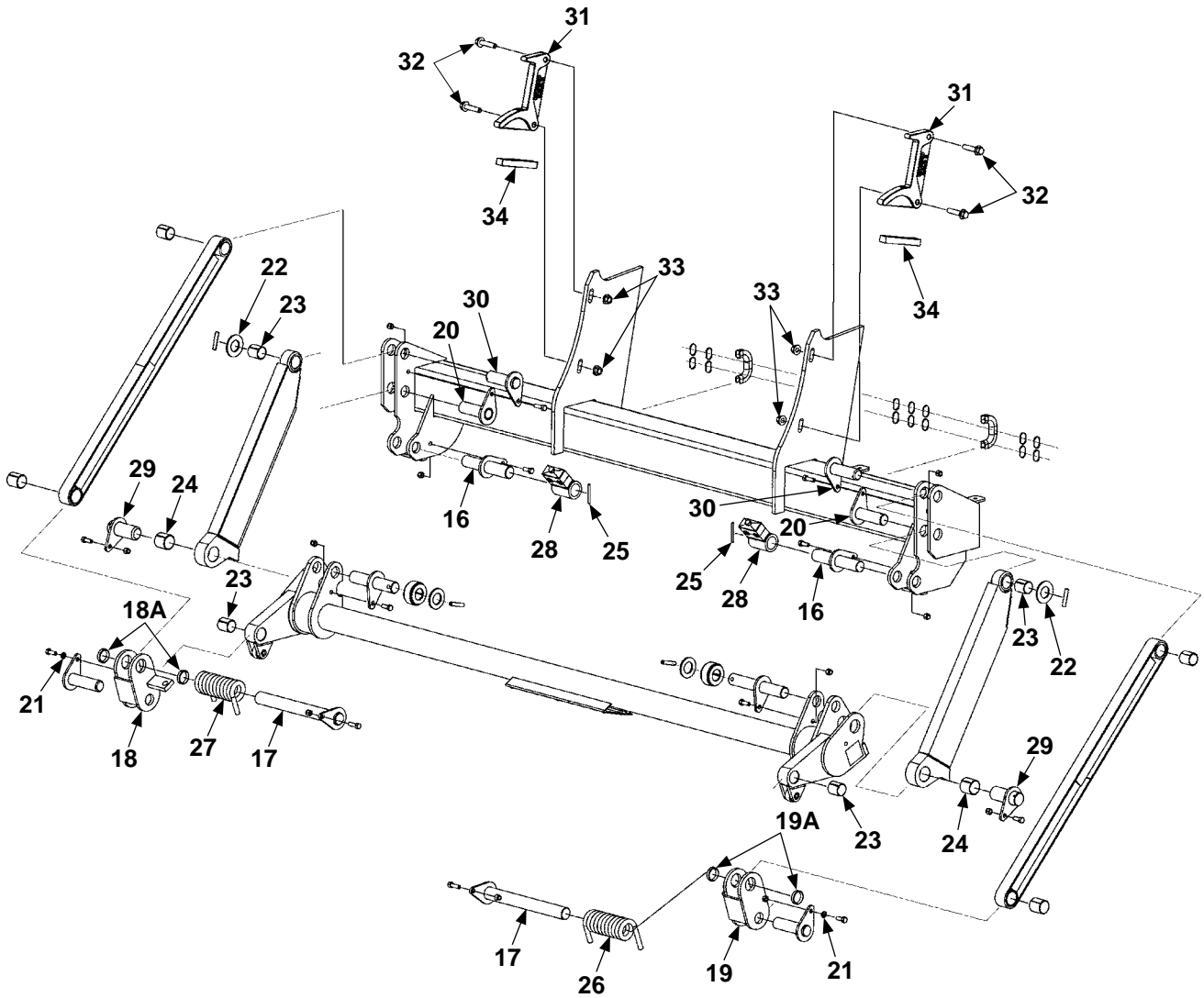

| ITEM | QTY. | PART NO. | DESCRIPTION |
|------|------|-----------|--|
| 16 | 2 | 262440 | PIN WELDMENT |
| 17 | 2 | 265807-01 | PIN WELDMENT, 1-3/8" X 13-1/8" LG. |
| 18 | 1 | 265815-01 | SHACKLE ASSEMBLY, LH |
| 18A | 2 | 905112-06 | BEARING, SELF LUBE, 1-3/8" X 3/8" LG. |
| 19 | 1 | 265815-02 | SHACKLE ASSEMBLY, RH |
| 19A | 2 | 905112-06 | BEARING, SELF LUBE, 1-3/8" X 3/8" LG. |
| 20 | 2 | 282446-01 | PIN WELDMENT |
| 21 | 2 | 902011-4 | LOCK WASHER, 3/8" |
| 22 | 2 | 902013-20 | FLAT WASHER, 1-1/4" |
| 23 | 4 | 905114-04 | BEARING, SELF LUBE 1-1/4" X 1-1/2" LG. |
| 24 | 2 | 905115-02 | BEARING, SELF LUBE 1-1/2" X 1-1/2" LG. |
| 25 | 2 | 907026 | ROLL PIN, 3/16" X 2-1/4" LG. |
| 26 | 1 | 226363-01 | TORSION SPRING, RH, 1/2" X 5-3/4" |
| 27 | 1 | 226363-02 | TORSION SPRING, LH, 1/2" X 5-3/4" |
| 28 | 2 | 262437 | BUSHING WELDMENT, HOSE CLAMP |
| 29 | 2 | 229657 | PIN WELDMENT |
| 30 | 2 | 250310 | PIN WELDMENT |
| 31 | 2 | 281539-01 | SADDLE, LOW PROFILE |
| 32 | 4 | 901024-3 | HEX BOLT, 1/2"-13 X 2-1/4" LG, GRADE 8 |
| 33 | 4 | 901023 | FLANGE LOCK NUT, 1/2"-13 |
| 34 | 2 | 090300-12 | FLAT, 3/4" X 1" X 6" LG. |

MAIN FRAME ASSEMBLY: GPT-4 & GPT-5

MAXON®

11921 Slauson Ave. Santa Fe Springs, CA. 90670 (800) 227-4116 FAX (888) 771-7713

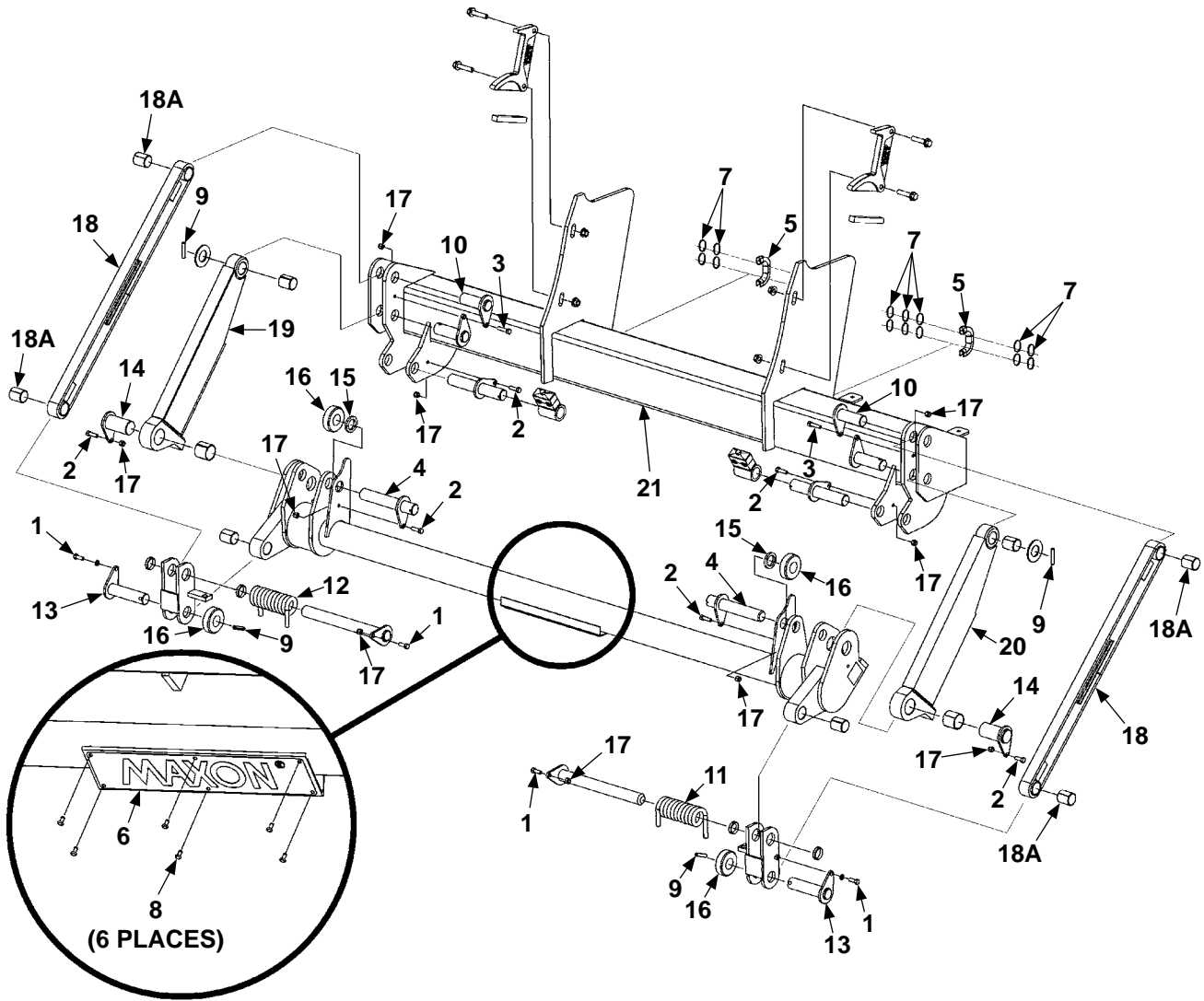

| ITEM | QTY. | PART NO. | DESCRIPTION |
|------|------|-----------|--|
| 1 | 4 | 030034 | BOLT, 3/8"-24 X 1" LG, GRADE 8 |
| 2 | 6 | 030035 | BOLT, 3/8"-24 X 1-1/4" LG, GRADE 8 |
| 3 | 2 | 030038 | BOLT, 3/8"-24 X 1-1/2" LG, GRADE 8 |
| 4 | 2 | 262435 | PIN WELDMENT |
| 5 | 2 | 040103-5 | SPLIT LOOM, 1/2 X 5" LG. |
| 6 | 1 | 050175 | MAXON PLATE, 3-1/4" X 15" LG. |
| 7 | 14 | 205780 | PLASTIC TIE, 7" LG. |
| 8 | 6 | 207644-01 | RIVET, 3/16" X .40" GRIP |
| 9 | 4 | 221416 | ROLL PIN, 3/8" X 2" LG. |
| 10 | 2 | 226358 | PIN WELDMENT |
| 11 | 1 | 226363-01 | TORSION SPRING, RH, 1/2" X 5-3/4" |
| 12 | 1 | 226363-02 | TORSION SPRING, LH, 1/2" X 5-3/4" |
| 13 | 2 | 226365 | PIN WELDMENT |
| 14 | 2 | 226368 | PIN WELDMENT |
| 15 | 2 | 226372 | ROUND TUBE X 1/4" (2" X 5/16" W) |
| 16 | 4 | 226375 | ROLLER (1" WIDE, 3-1/8" O.D.) |
| 17 | 10 | 226941 | NYLON LOCK NUT, 3/8"-24 |
| 18 | 2 | 261785-01 | PARALLEL ARM |
| 18A | 4 | 905112-07 | BEARING, SELF LUBE 1-3/8" X 1-3/4" LG. |
| 19 | 1 | 262332-01 | LIFT ARM WELDMENT, RH |
| 20 | 1 | 262332-02 | LIFT ARM WELDMENT, LH |
| 21 | 1 | 282472-01 | MAIN FRAME |

MAIN FRAME ASSEMBLY: GPT-4 & GPT-5 - Continued

MAXON[®]

11921 Slauson Ave. Santa Fe Springs, CA. 90670 (800) 227-4116 FAX (888) 771-7713

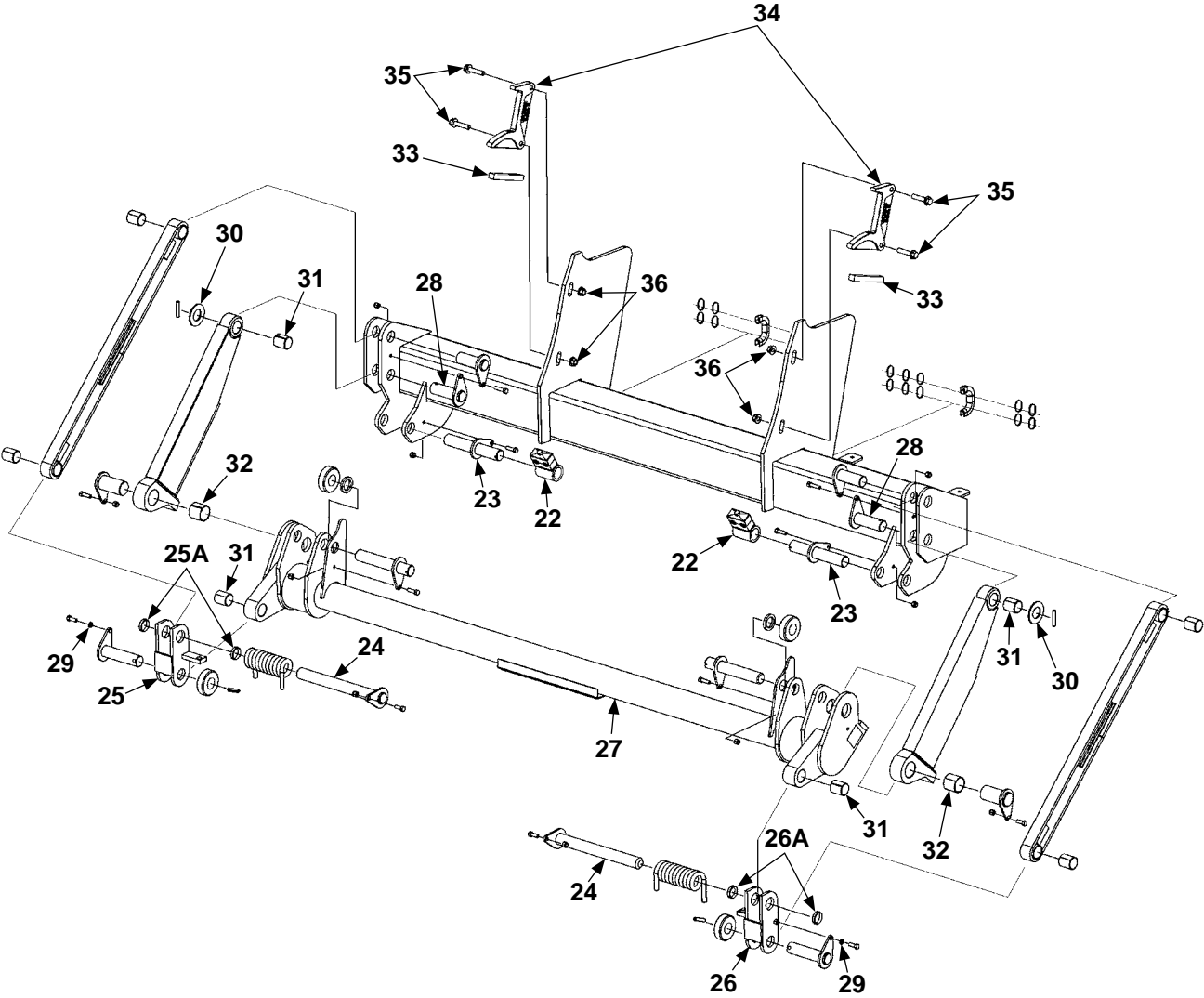

| ITEM | QTY. | PART NO. | DESCRIPTION |
|------|------|-----------|--|
| 22 | 2 | 262437 | BUSHING WELDMENT, HOSE CLAMP |
| 23 | 2 | 262462 | PIN WELDMENT |
| 24 | 2 | 265807-01 | PIN WELDMENT, 1-3/8" X 13-1/8" LG. |
| 25 | 1 | 265813-01 | SHACKLE ASSEMBLY, LH |
| 25A | 2 | 905112-06 | BEARING, SELF LUBE 1-3/8" X 3/8" LG. |
| 26 | 1 | 265813-02 | SHACKLE ASSEMBLY, RH |
| 26A | 2 | 905112-06 | BEARING, SELF LUBE 1-3/8" X 3/8" LG. |
| 27 | 1 | 262397 | LIFT FRAME WELDMENT |
| 28 | 2 | 266033-01 | PIN WELDMENT (UNDERRIDE) |
| 29 | 2 | 902011-4 | LOCK WASHER, 3/8" |
| 30 | 2 | 902013-21 | FLAT WASHER, 1-3/8" |
| 31 | 4 | 905112-07 | BEARING, SELF LUBE 1-3/8" X 1-3/4" LG. |
| 32 | 2 | 905113-03 | BEARING, SELF LUBE 1-3/4" X 1-3/4" LG. |
| 33 | 2 | 090300-12 | FLAT, 3/4" X 1" X 6" LG. |
| 34 | 2 | 281539-01 | SADDLE, LOW PROFILE |
| 35 | 4 | 901024-3 | HEX BOLT, 1/2"-13 X 2-1/4" LG, GRADE 8 |
| 36 | 4 | 901023 | FLANGE LOCK NUT, 1/2"-13 |

PLATFORM & FLIPOVER ASSEMBLY (ALUMINUM)

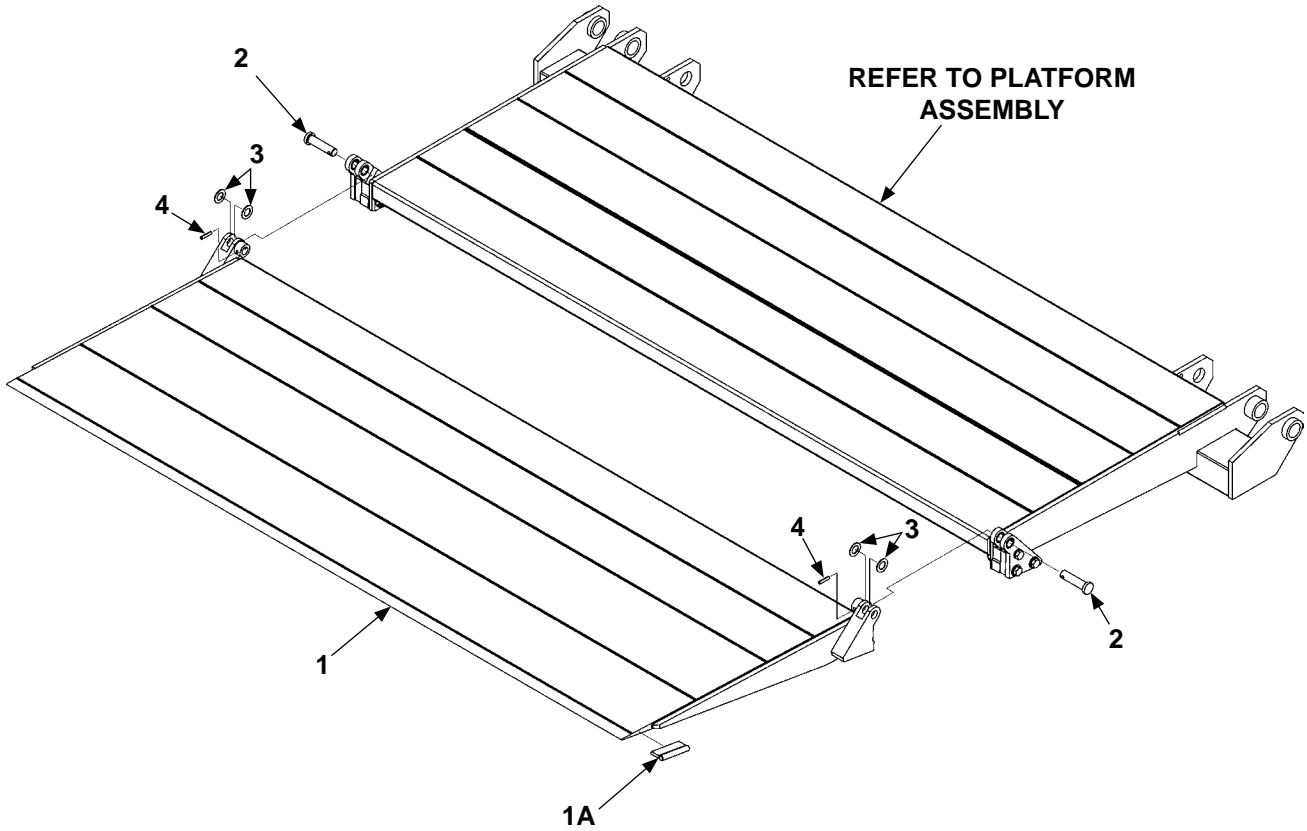

| ITEM | QTY. | PART NO. | DESCRIPTION |
|------|------|-----------|---|
| 1 | 1 | 281512-01 | FLIPOVER WELDMENT, 30" |
| 1A | 1 | 265819-01 | HANDLE WELDMENT |
| 2 | 2 | 263602 | HINGE PIN WELDMENT |
| 3 | 4 | 902020-1 | FLAT WASHER, NYLON, 3/4" I.D., 1-5/16" O.D. |
| 4 | 2 | 905033-2 | ROLL PIN, 1/4" X 1-1/4" LG. |

MAXON®

11921 Slauson Ave. Santa Fe Springs, CA. 90670 (800) 227-4116 FAX (888) 771-7713

PLATFORM & FLIPOVER ASSEMBLY WITH CART STOPS (ALUMINUM)

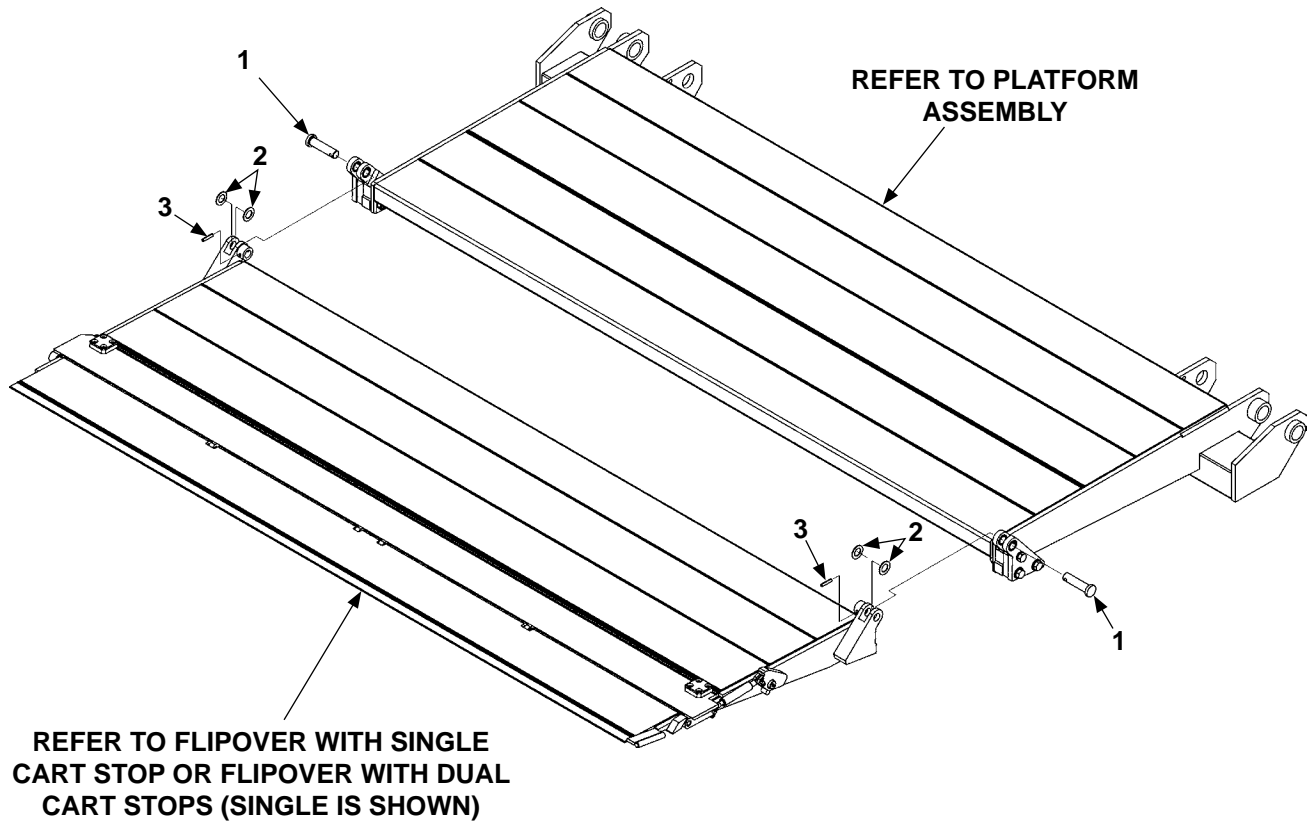

| ITEM | QTY. | PART NO. | DESCRIPTION |
|------|------|----------|---|
| 1 | 2 | 263602 | HINGE PIN WELDMENT |
| 2 | 4 | 902020-1 | FLAT WASHER, NYLON, 3/4" I.D., 1-5/16" O.D. |
| 3 | 2 | 905033-2 | ROLL PIN, 1/4" X 1-1/4" LG. |

PLATFORM ASSEMBLY (ALUMINUM)

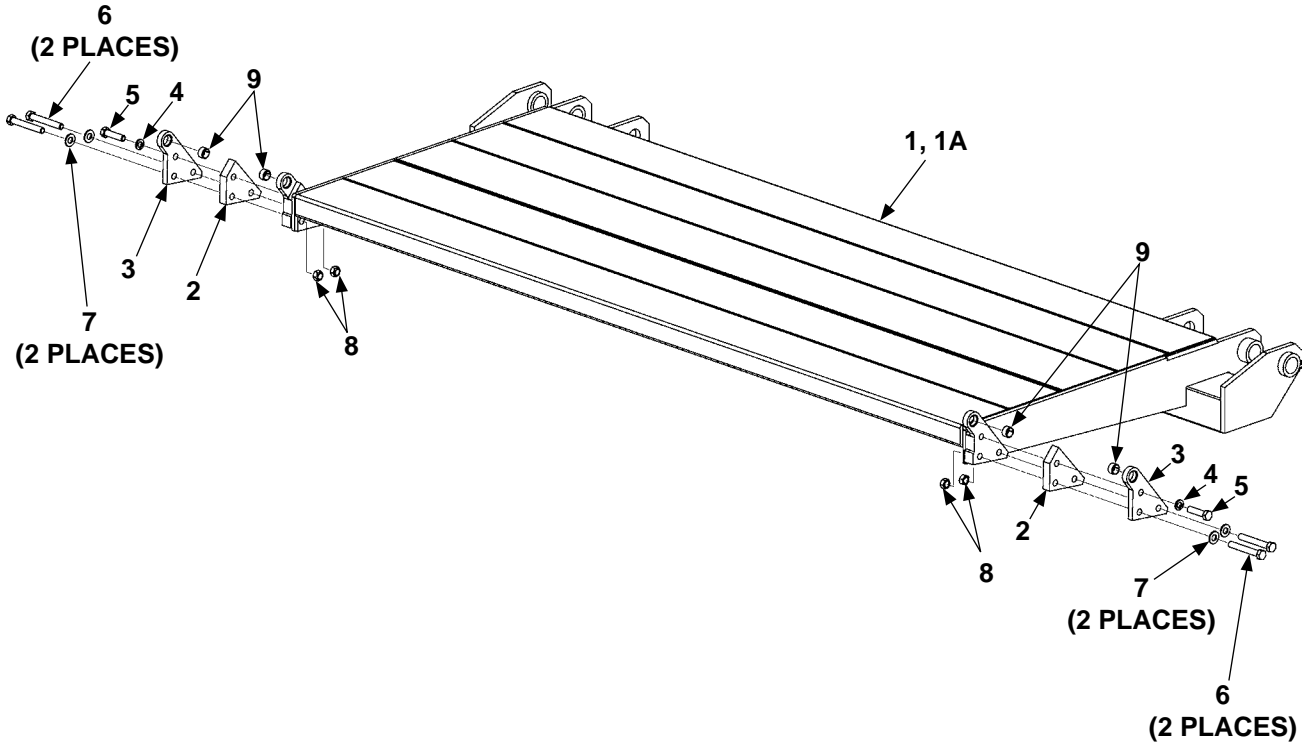

| ITEM | QTY. | PART NO. | DESCRIPTION |
|------|------|-----------|---------------------------------|
| 1 | 1 | 281510-01 | PLATFORM ASSEMBLY, 30" |
| 1A | 1 | 281508-01 | PLATFORM WELDMENT, 30" |
| 2 | 2 | 263608 | HINGE BRACKET, INSIDE |
| 3 | 2 | 263609 | HINGE BRACKET, OUTSIDE |
| 4 | 2 | 902011-6 | LOCK WASHER, 1/2" |
| 5 | 2 | 900035-5 | CAP SCREW, 1/2"-20 X 2" LG. |
| 6 | 4 | 900035-10 | CAP SCREW, 1/2"-13 X 3-1/2" LG. |
| 7 | 4 | 902013-13 | FLAT WASHER, 1/2" |
| 8 | 4 | 040066 | LOCK NUT, 1/2"-13 |
| 9 | 4 | 260917-04 | SELF LUBE BEARING, 1/2" LG. |

MAXON®

11921 Slauson Ave. Santa Fe Springs, CA. 90670 (800) 227-4116 FAX (888) 771-7713

THIS PAGE INTENTIONALLY LEFT BLANK

FLIPOVER WITH SINGLE CART STOP (ALUMINUM)

MAXON®

11921 Slauson Ave. Santa Fe Springs, CA. 90670 (800) 227-4116 FAX (888) 771-7713

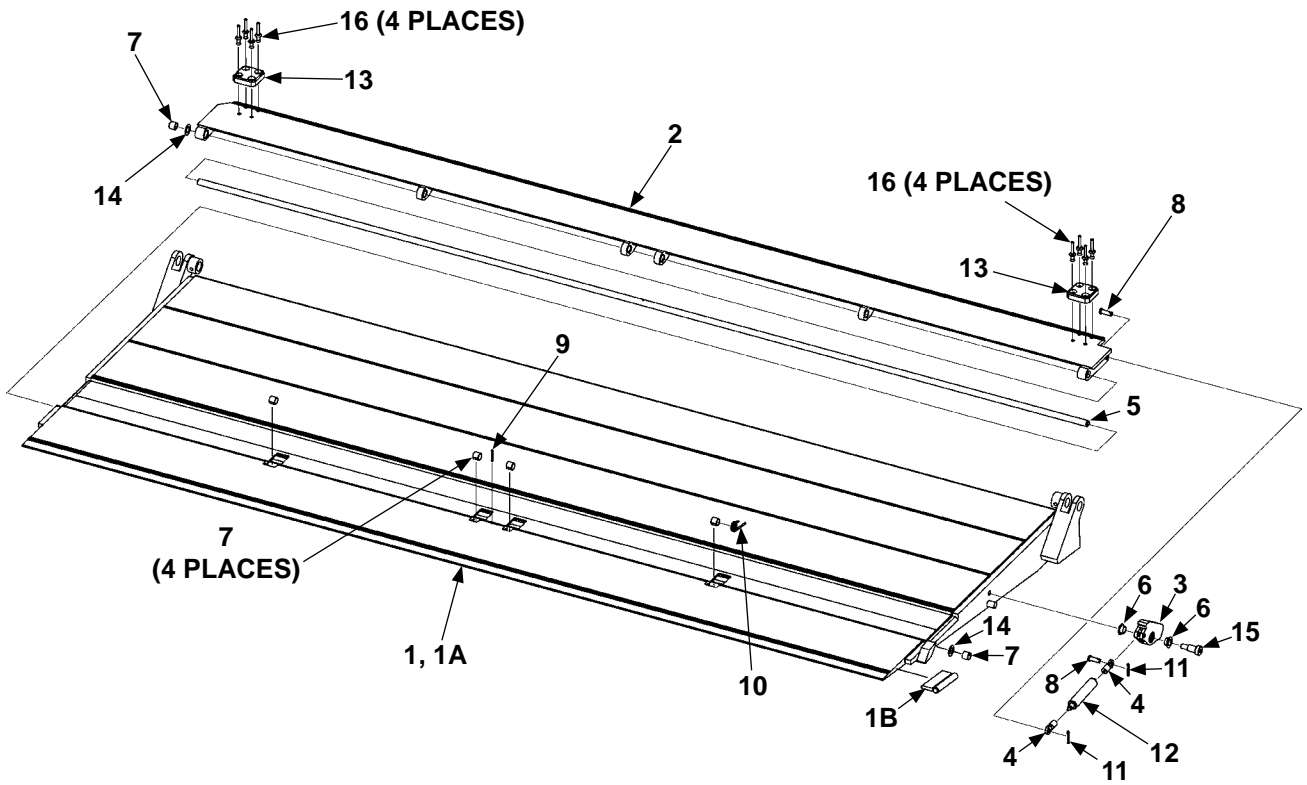

| ITEM | QTY. | PART NO. | DESCRIPTION |
|------|------|-----------|---|
| 1 | 1 | 281533-01 | FLIPOVER ASSEMBLY, SINGLE CART STOP 30" |
| 1A | 1 | 281513-01 | FLIPOVER WELDMENT, SINGLE CART STOP |
| 1B | 1 | 265819-01 | HANDLE WELDMENT |
| 2 | 1 | 262508-02 | SINGLE CART STOP RAMP WELDMENT |
| 3 | 1 | 262481-02 | OPENING AND CLOSING ARM, RH |
| 4 | 2 | 262515 | METAL EYELET END FITING |
| 5 | 1 | 262513-01 | PIN, 80-5/8" LG. |
| 6 | 2 | 905122-02 | SELF LUBE BEARING, 1/2" X 5/16" LG. |
| 7 | 6 | 253542 | SELF LUBE BEARING, 1/2" X 1/2" LG. |
| 8 | 2 | 905135 | CLEVIS PIN, 5/16" X 7/8" LG. |
| 9 | 1 | 030406 | ROLL PIN, 1/8" X 1" LG. |
| 10 | 1 | 262536 | TORSION SPRING |
| 11 | 2 | 030805 | COTTER PIN, 1/8" X 1" LG. |
| 12 | 1 | 262514 | GAS SPRING, 90 LBS. |
| 13 | 2 | 281536-01 | STOP BLOCK |
| 14 | 2 | 902022 | WASHER, 1/2" |
| 15 | 1 | 900047 | SHOULDER SCREW, 1/2" X 3/4" LG. |
| 16 | 8 | 903705-02 | RIVET, BLIND, 1/4" X 5/8" LG. |

FLIPOVER WITH DUAL CART STOPS (ALUMINUM)

MAXON[®]

11921 Slauson Ave. Santa Fe Springs, CA. 90670 (800) 227-4116 FAX (888) 771-7713

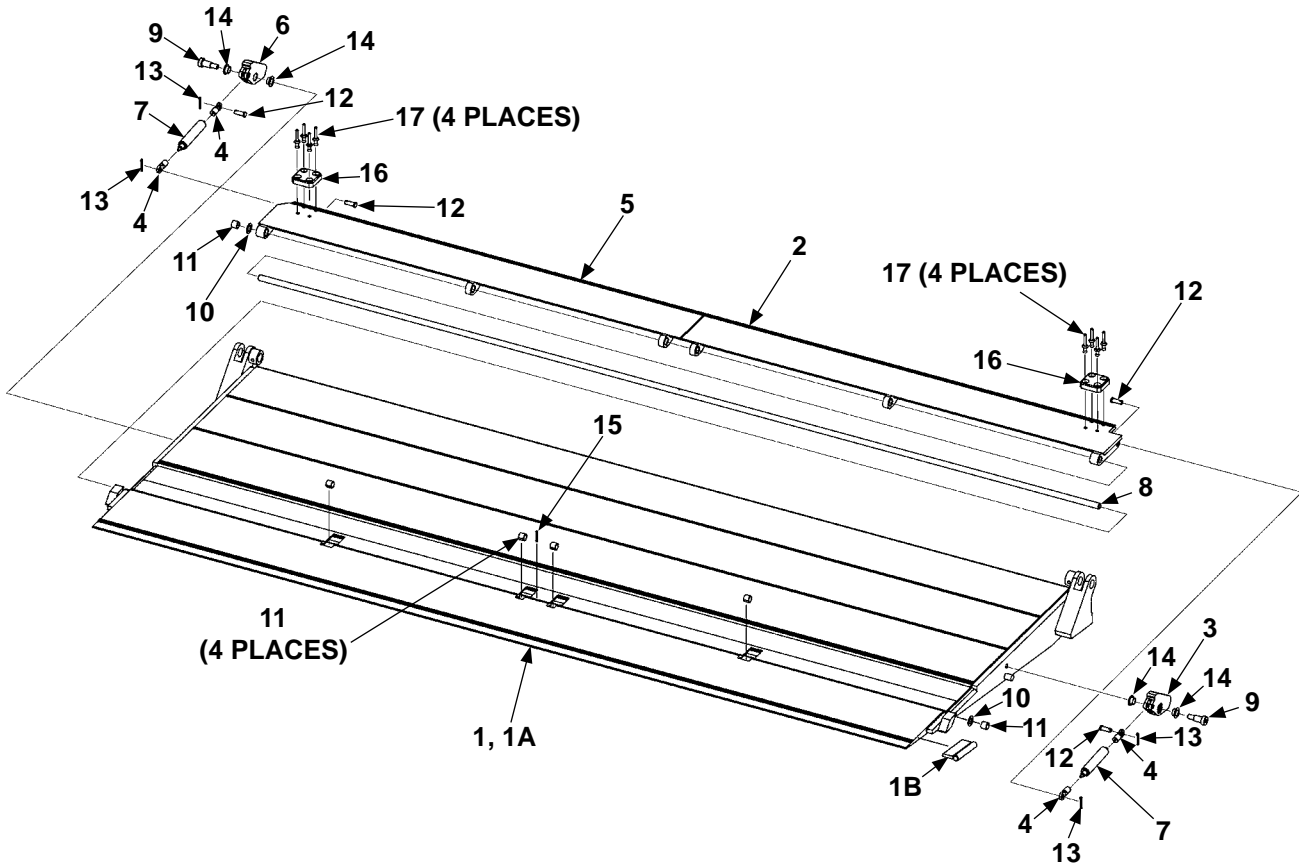

| ITEM | QTY. | PART NO. | DESCRIPTION |
|------|------|-----------|---------------------------------------|
| 1 | 1 | 281532-01 | FLIPOVER ASSEMBLY, DUAL CART STOP 30" |
| 1A | 1 | 281513-02 | FLIPOVER WELDMENT, DUAL CART STOP |
| 1B | 1 | 265819-01 | HANDLE WELDMENT |
| 2 | 1 | 262509-06 | DUAL CART STOP RAMP WELDMENT, RH |
| 3 | 1 | 262481-02 | OPENING AND CLOSING ARM, RH |
| 4 | 4 | 262515 | METAL EYELET END FITING |
| 5 | 1 | 262509-05 | DUAL CART STOP RAMP WELDMENT, LH |
| 6 | 1 | 262481-01 | OPENING AND CLOSING ARM, LH |
| 7 | 2 | 262514 | GAS SPRING, 90 LBS. |
| 8 | 1 | 262513-01 | PIN, 80-5/8" LG. |
| 9 | 2 | 900047 | SHOULDER SCREW, 1/2" X 3/4" LG. |
| 10 | 2 | 902022 | WASHER, 1/2" |
| 11 | 6 | 253542 | SELF LUBE BEARING, 1/2" X 1/2" LG. |
| 12 | 4 | 905135 | CLEVIS PIN, 5/16" X 7/8" LG. |
| 13 | 4 | 030805 | COTTER PIN, 1/8" X 1" LG. |
| 14 | 4 | 905122-02 | SELF LUBE BEARING, 1/2" X 5/16" LG. |
| 15 | 1 | 030406 | ROLL PIN, 1/8" X 1" LG. |
| 16 | 2 | 281536-01 | STOP BLOCK |
| 17 | 8 | 903705-02 | RIVET, BLIND, 1/4" X 5/8" LG. |

DOCK BUMPER

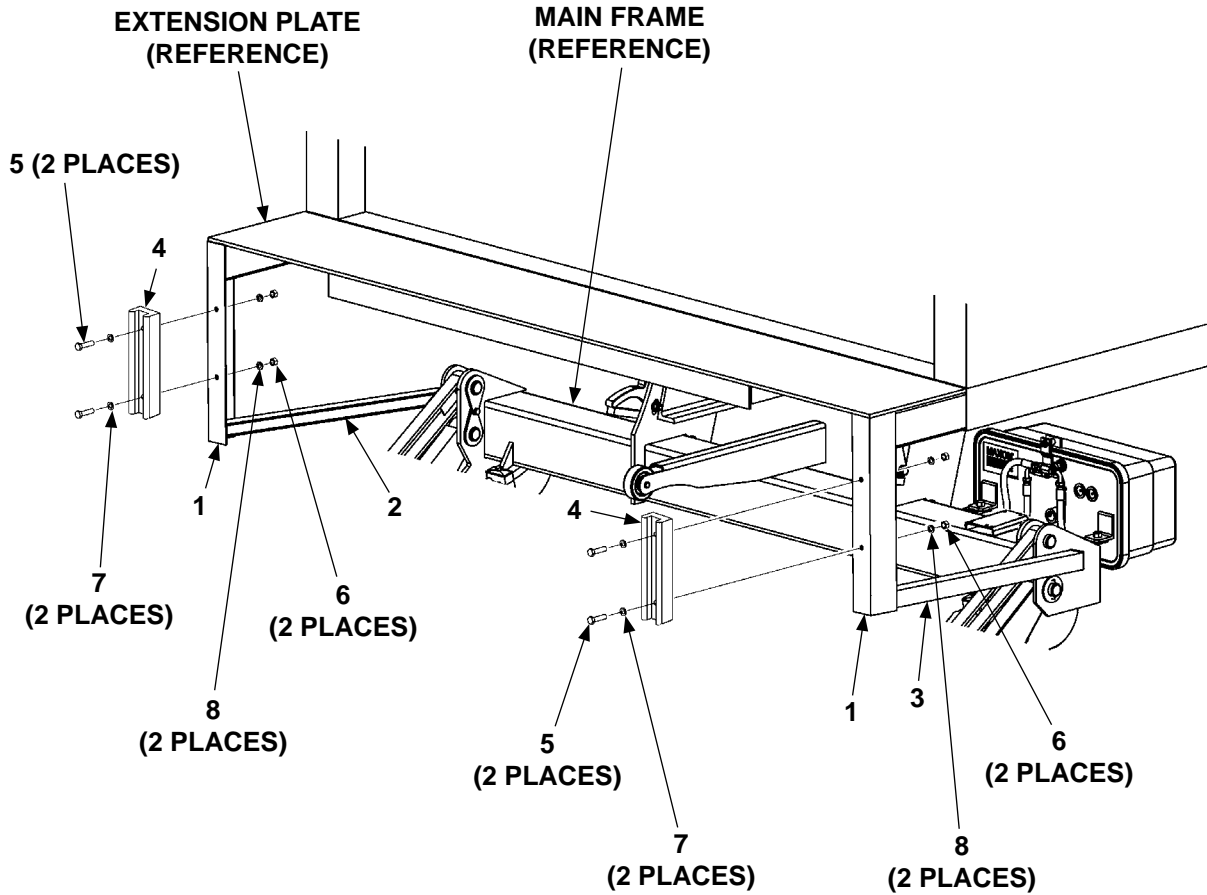

| ITEM | QTY. | PART NO. | DESCRIPTION |
|------|------|-----------|--------------------------------|
| 1 | 2 | 226856 | DOCK BUMPER ANGLE, 23-1/2" LG. |
| 2 | 1 | 266019-01 | BRACE ANGLE, LH |
| 3 | 1 | 266019-02 | BRACE ANGLE, RH |
| 4 | 2 | 222988 | BUMPER |
| 5 | 4 | 900033-5 | CAP SCREW, 1/2"-20 X 2" LG. |
| 6 | 4 | 901011-10 | NUT, 1/2"-20 |
| 7 | 4 | 902000-14 | FLAT WASHER, 1/2" |
| 8 | 4 | 902011-6 | LOCK WASHER, 1/2" |

MAXON[®]

11921 Slauson Ave. Santa Fe Springs, CA. 90670 (800) 227-4116 FAX (888) 771-7713

PUMP ASSEMBLY

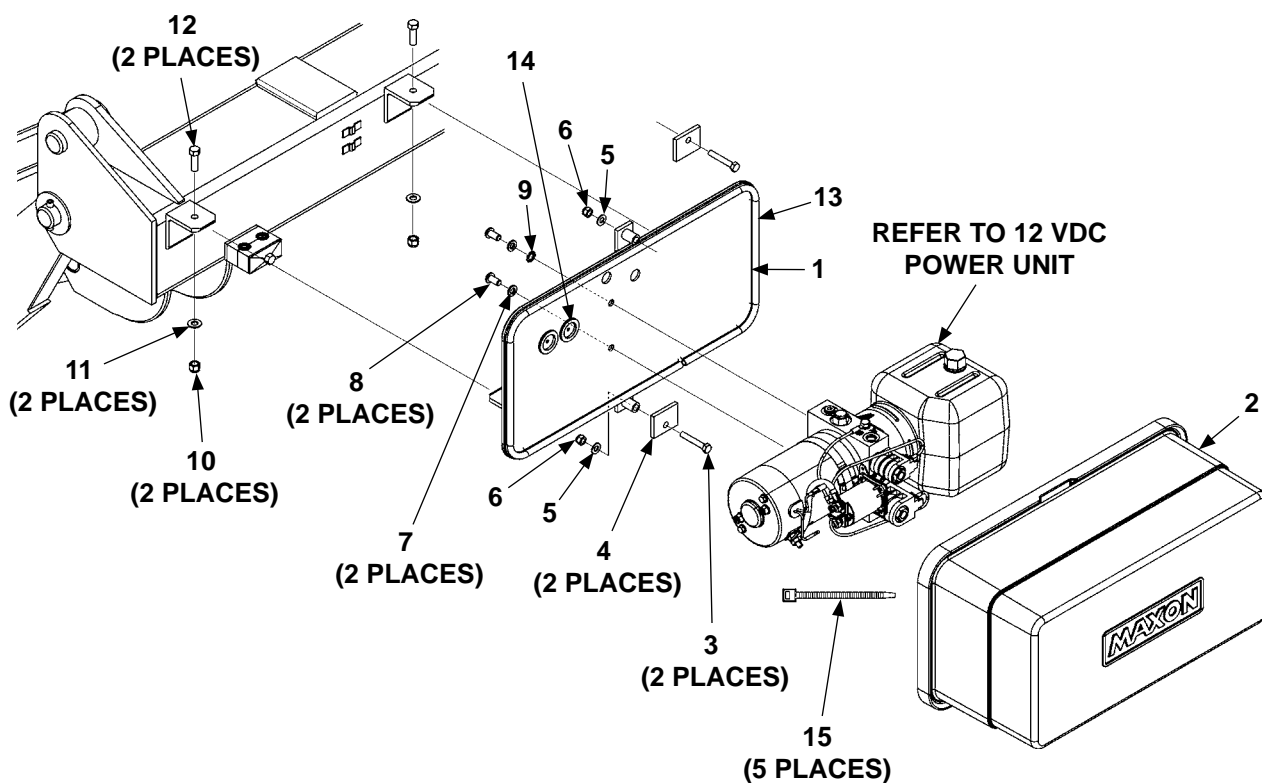

| ITEM | QTY. | PART NO. | DESCRIPTION |
|------|------|-----------|---|
| REF | 1 | 267990-01 | PUMP ASSY, HEAVY DUTY, POWER DOWN |
| 1 | 1 | 267992-01 | PLATE, PUMP MOUNT |
| 2 | 1 | 281038-02 | PUMP COVER |
| 3 | 2 | 900009-8 | CAP SCREW, 5/16"-18 X 2" LG, GRADE 8 |
| 4 | 2 | 281062-02 | FLAT, HOLDER |
| 5 | 2 | 901001 | NYLON LOCK NUT, 5/16"-18 |
| 6 | 2 | 902013-10 | FLAT WASHER, 5/16" |
| 7 | 2 | 902011-4 | LOCK WASHER, 3/8" |
| 8 | 2 | 900064-03 | BUTTON SCREW, 3/8"-16 X 3/4" LG. |
| 9 | 4 | 903400-02 | EXTERNAL TOOTH WASHER, 3/8" |
| 10 | 2 | 901002 | NYLON LOCK NUT, 3/8"-16 |
| 11 | 2 | 902001-2 | FLAT WASHER, 3/8" |
| 12 | 2 | 900014-5 | HEX CAP SCREW, 3/8"-16 X 1-1/4" LG, GRADE 8 |
| 13 | 1 | 093203-10 | NEOPRENE SEAL, 60" LG. |
| 14 | 2 | 266428-01 | GROMMET, 1" O.D. X 3/16" I.D. |
| 15 | 5 | 208153 | PLASTIC TIE, 4" LG. (CONTROL CABLE & PUMP WIRING) |

HYDRAULIC COMPONENTS - POWER DOWN

CAUTION

If the Liftgate is equipped with a bumper (ICC-type), replacement hydraulic hoses must be routed with sufficient clearance from the bumper. The clearance prevents the hoses from rubbing or getting caught on the bumper.

NOTE: Replacement face seal fittings come with required O-rings.

NOTE: Hoses routed to each cylinder are secured with a spacer & ties. RH cylinder is shown below.

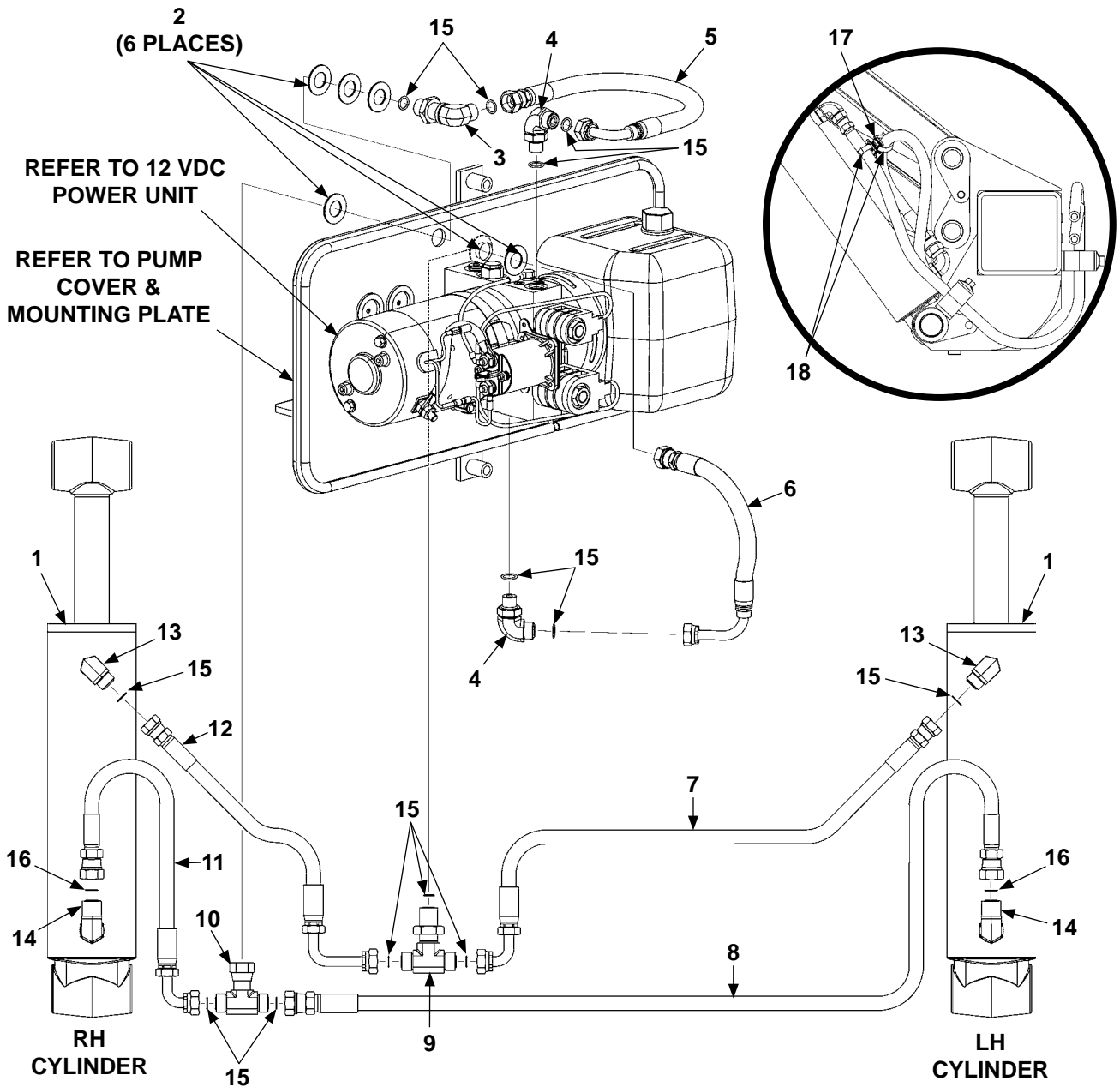

MAXON[®]
 11921 Slauson Ave. Santa Fe Springs, CA. 90670 (800) 227-4116 FAX (888) 771-7713

| ITEM | QTY. | PART NO. | DESCRIPTION |
|------|------|-----------|---|
| 1 | 2 | 266037-01 | CYLINDER, 2-3/4" DIA. x 10" STROKE (GPT-25 & GPT-3) |
| | | 266038-01 | CYLINDER, 3" DIA. x 10" STROKE (GPT-4) |
| | | 266039-01 | CYLINDER, 3-1/2" DIA. x 10" STROKE (GPT-5) |
| 2 | 6 | 902028-12 | FLAT WASHER, 1-1/4" O.D. X 3/4" I.D. |
| 3 | 1 | 905162 | ELBOW, BULKHEAD UNION, SAE #6, FACE SEAL O-RING |
| 4 | 2 | 906707-01 | ELBOW, SAE #6, FACE SEAL O-RING, M-M |
| 5 | 1 | 268023-01 | HOSE ASSY, 3/8" HP, SAE #6, 16" LG. |
| 6 | 1 | 267988-01 | HOSE ASSY, 3/8" HP, SAE #6, 11" LG. |
| 7 | 1 | 267987-01 | HOSE ASSY, 3/8" HP, SAE #6, 100" LG. |
| 8 | 1 | 267986-01 | HOSE ASSY, 3/8" HP, SAE #6-#8, 110" LG. |
| 9 | 1 | 906810-01 | BRANCH TEE, BULKHEAD, SAE #6, FACE SEAL O-RING |
| 10 | 1 | 906802-01 | BRANCH TEE, SWIVEL NUT, SAE #6, FACE SEAL O-RING |
| 11 | 1 | 267994-01 | HOSE ASSY, 3/8" HP, SAE #6-#8, 43" LG. |
| 12 | 1 | 267995-01 | HOSE ASSY, 3/8" HP, SAE #6, 34" LG. |
| 13 | 2 | 906707-01 | ELBOW, SAE #6, FACE SEAL O-RING, M-M |
| 14 | 2 | 906704-01 | ELBOW, SAE #8, FACE SEAL O-RING, M-M |
| 15 | 13 | 906712-02 | O-RING #6 (3/8" FACE SEAL TUBE-END) |
| 16 | 2 | 906712-03 | O-RING #8 (1/2" FACE SEAL TUBE-END) |
| 17 | 2 | 906545-01 | DUAL SWIVEL SPACER (HYDRAULIC HOSES) |
| 18 | 4 | 905322-01 | PLASTIC TIE, 8" |

12 VDC POWER UNIT

CAUTION

Do not over-tighten the terminal nuts on starter solenoid. For the load terminals, torque nuts to 40 lbs.-in. max. Torque the nuts on #10-32 control terminals 15-20 lbs.-in.

CAUTION

To prevent damage when installing 2-way valves, torque valve cartridge nut to 30 lbs.-in. max.

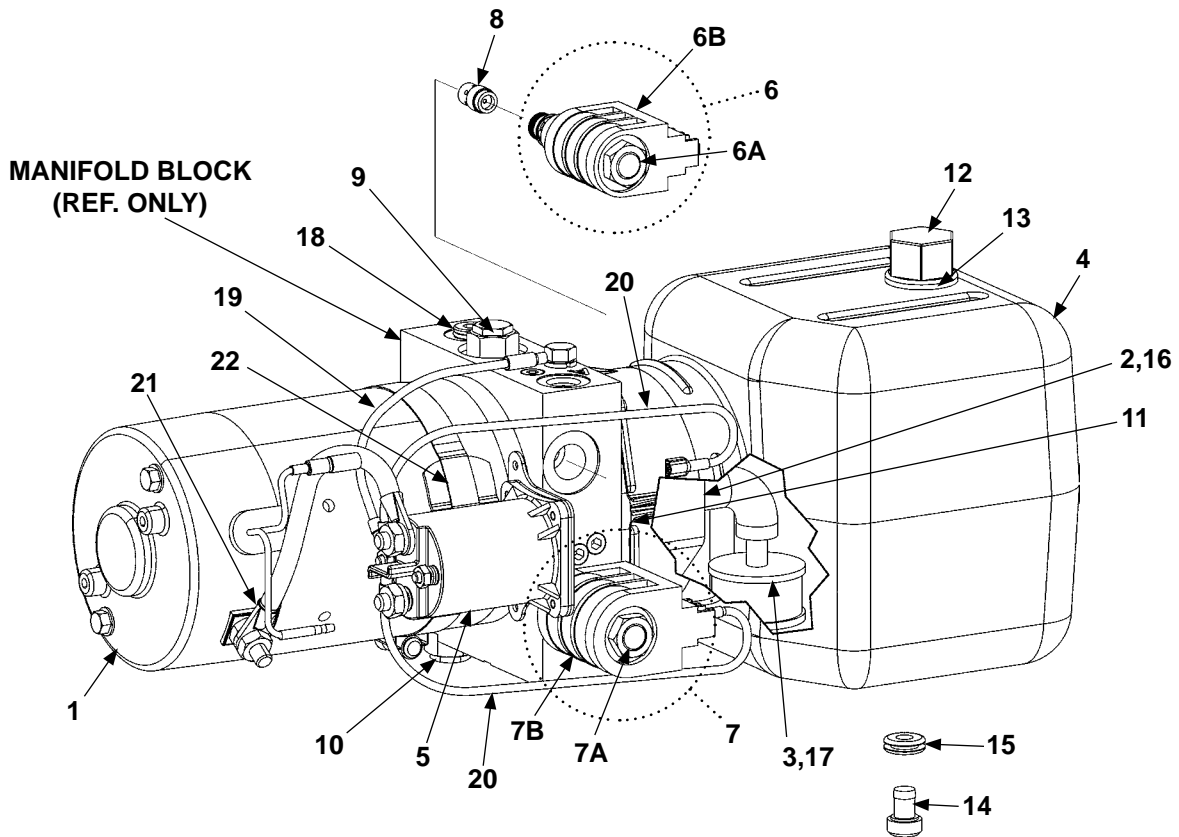

MAXON[®]

11921 Slauson Ave. Santa Fe Springs, CA. 90670 (800) 227-4116 FAX (888) 771-7713

| ITEM | QTY. | PART NO. | DESCRIPTION |
|------|------|-----------|--|
| REF | 1 | 267991-01 | 12 VDC POWER UNIT |
| 1 | 1 | 268011-01 | MOTOR, 12 VDC, HEAVY DUTY |
| 2 | 1 | 268021-01 | PUMP ASSEMBLY |
| 3 | 1 | 268013-01 | FILTER, PUMP INLET |
| 4 | 1 | 268020-01 | RESERVOIR, SQUARE CUT, 1 GALLON |
| 5 | 1 | 268030-01 | SWITCH, SOLENOID (12 VDC) |
| 6 | 1 | 290043 | VALVE ASSEMBLY, 2-WAY (2-POLE) |
| 6A | 1 | 290044 | VALVE CARTRIDGE (2-WAY VALVE) |
| 6B | 1 | 290045 | COIL, DOUBLE SPADE (2-WAY VALVE) |
| 7 | 1 | 290046 | VALVE ASSEMBLY, 4-WAY (2-POLE) |
| 7A | 1 | 290047 | VALVE CARTRIDGE (4-WAY VALVE) |
| 7B | 1 | 290048 | COIL, DOUBLE SPADE (4-WAY VALVE) |
| 8 | 1 | 268017-01 | FLOW CONTROL VALVE, 4 GPM |
| 9 | 1 | 906738-02 | RELIEF VALVE, ADJUSTABLE, 3200 PSI |
| 10 | 1 | 268174-01 | RELIEF VALVE, ADJUSTABLE, 1100 PSI |
| 11 | 1 | 290061 | SEAL, SQUARE CUT (FOR RESERVOIR) |
| 12 | 1 | 280806-01 | FILLER, BREATHER CAP |
| 13 | 1 | 908016-01 | GROMMET (FILLER CAP) |
| 14 | 1 | 908017-01 | PLUG, DRAIN PORT |
| 15 | 1 | 908018-01 | RUBBER GROMMET, 5/16" I.D. (DRAIN PLUG) |
| 16 | 1 | 260261 | OIL SEAL, PUMP |
| 17 | 1 | 290020 | O-RING (NOT SHOWN) |
| 18 | 1 | 261067 | PLUG, O-RING, SAE #6 |
| 19 | 1 | 268027-01 | WIRE ASSY, 18 GA (#10 RING & 5/16" RING TERMINALS) |
| 20 | 2 | 268016-01 | WIRE ASSY (#10 RING & QUICK DISCONN. TERMINALS) |
| 21 | 1 | 280404 | CABLE ASSEMBLY |
| 22 | 1 | 268019-01 | CLAMP, STARTER SOLENOID |

MAXON[®]

11921 Slauson Ave. Santa Fe Springs, CA. 90670 (800) 227-4116 FAX (888) 771-7713

THIS PAGE INTENTIONALLY LEFT BLANK

CONTROL SWITCH AND POWER CABLE

NOTE: Use switch to raise and lower Liftgate to make sure switch operates as shown on the decal.

NOTE: MAXON recommends using dielectric grease on all electrical connections.

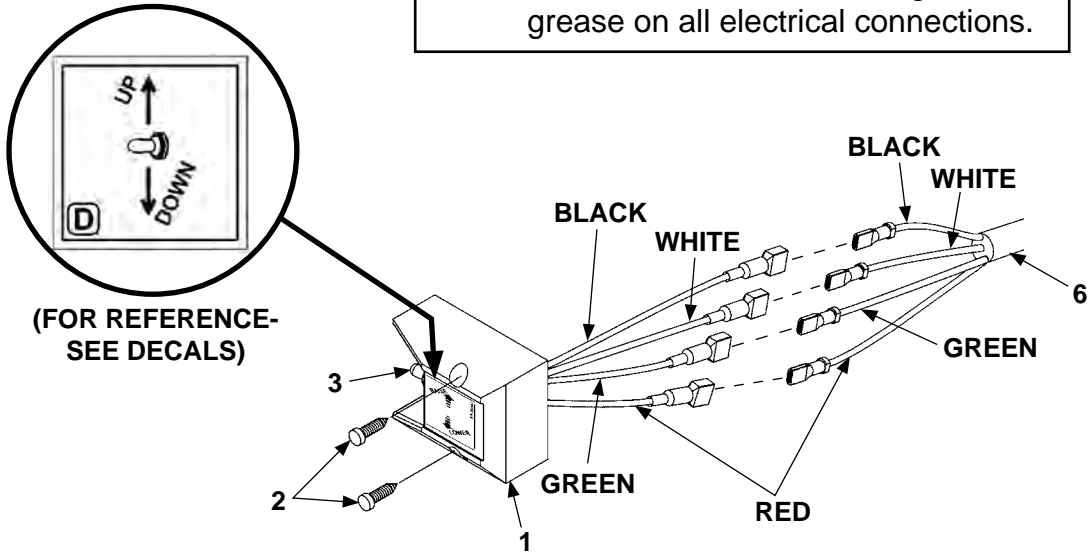

FIG. 43-1

| ITEM | QTY. | PART NO. | DESCRIPTION |
|------|------|-----------|--|
| 1 | 1 | 264951-04 | MOLD SWITCH ASSEMBLY |
| 2 | 2 | 900057-5 | SCREW, SELF-TAPPING #10-24 X 1" LG. |
| 3 | 1 | 905206 | SWITCH BOOT SEAL |
| 4 | 1 | 264422 | CABLE ASSEMBLY, 175 AMPS, 38' LG. |
| 5 | 1 | 264687 | KIT, MEGAFUSE (175 AMP FUSE & HEATSHRINK TUBING) |
| 6 | 1 | 268170-01 | CABLE ASSEMBLY |

TABLE 43-1

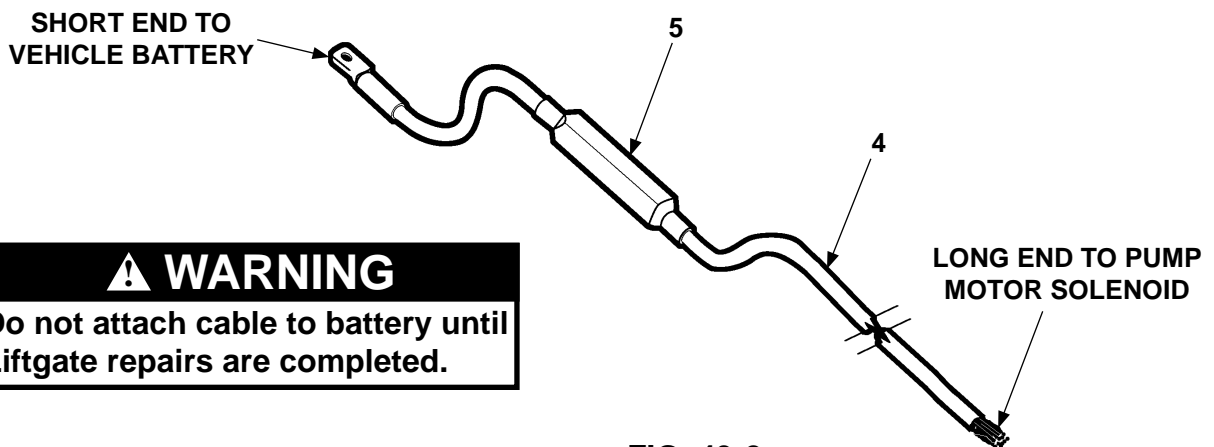

FIG. 43-2

⚠ WARNING
Do not attach cable to battery until Liftgate repairs are completed.

DECALS



DECAL "H" (2 PLACES)
 P/N 268308-01



PAINT DECAL
 P/N 267338-01

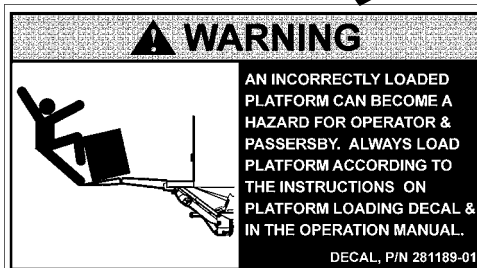

PLATFORM WARNING DECAL
 (2 PLACES)
 P/N 281189-01

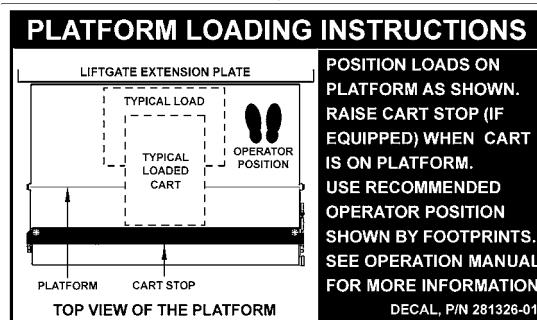

PLATFORM LOADING DECAL
 (2 PLACES)
 P/N 281326-01

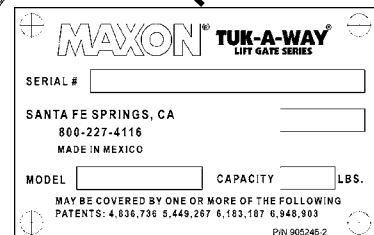

SERIAL PLATE
 (REF)

FIG. 44-1

SAFETY INSTRUCTIONS

Read all decals and operation manual before operating liftgate.

1. Do not use liftgate unless you have been properly instructed and have read, and are familiar with, the operating instructions.
2. Be certain vehicle is properly and securely braked before using the liftgate.
3. Always inspect this liftgate for maintenance or damage before using it. Do not use liftgate if it shows any sign of damage or improper maintenance.
4. Do not overload
5. Make certain the area in which the platform will open and close is clear before opening or closing the platform.
6. Make certain platform area, including the area in which loads may fall from platform, is clear before and at all times during operation of liftgate.
7. This liftgate is intended for loading and unloading of cargo only. Do not use this liftgate for anything but its intended use.

(A)

WARNING

Liftgate hazards can result in crushing or falling. Keep hands and feet clear of pinch points. If riding liftgate, make sure load is stable and footing is solid.



Read and understand all instructions and WARNINGS before use.

(G)

WARNING

Read this information carefully.

- Improper operation of this Liftgate can result in serious personal injury. If you do not have a copy of the operating instructions, please obtain them from your employer, distributor, or lessor before you attempt to operate Liftgate.
- If there are signs of improper maintenance, damage to vital parts, or slippery platform surface, do not use the Liftgate until these problems have been corrected.
- If you are using a pallet jack, be sure it can be maneuvered safely.
- Do not operate a forklift on the platform.
- Do not allow any part of yours or your helper's body to be placed under, within, or around any portion of the moving Liftgate, or its mechanisms, or in a position that would trap them between the platform and the ground or truck when the Liftgate is operated.
- If a helper is riding the platform with you, make sure you are both doing so safely and that you are not in danger of coming in contact with any moving or potentially moving obstacles.
- **USE GOOD COMMON SENSE.**
- If load appears to be unsafe, do not lift or lower it.

For a free copy of other manuals that pertain to this model Liftgate, please visit our website at www.maxonlift.com or call Customer Service at (800) 227-4116.

(I)

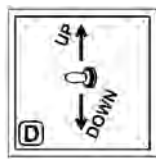

OPERATING INSTRUCTIONS

GPT Series Liftgates

1. Unhook safety chain. (See CAUTION decal.)
2. Push control switch. (Must touch the ground)
3. Unfold platform.
4. Unfold flipover.
5. Use switch to raise or lower.
6. To tuck liftgate away, reverse steps 1, 2, 3, & 4.

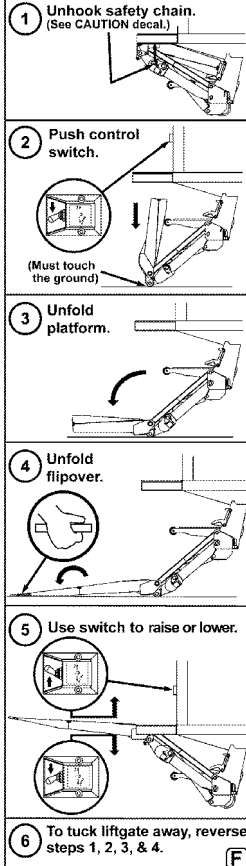

(F)

CAUTION

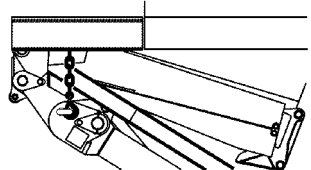

Avoid possible injury & damage. Make certain chain is hooked to pad eye when platform is stowed.

(C)

CAUTION

Always stand clear of platform area.

(E)

THE MAXIMUM CAPACITY OF THIS LIFT IS

POUNDS

WHEN THE LOAD IS CENTERED ON THE LOAD CARRYING PLATFORM

(B)

(See TABLE 45-1)

DECAL SHEET
FIG. 45-1

| MODEL | DECAL SHEET P/N | DECAL "B" |
|--------|-----------------|-------------|
| GPT-25 | 268308-01 | 2500 POUNDS |
| GPT-3 | 268308-02 | 3000 POUNDS |
| GPT-4 | 268308-03 | 4000 POUNDS |
| GPT-5 | 268308-04 | 5000 POUNDS |

DECAL SHEET
TABLE 45-1

MAXON®

11921 Slauson Ave. Santa Fe Springs, CA. 90670 (800) 227-4116 FAX (888) 771-7713

THIS PAGE INTENTIONALLY LEFT BLANK

SYSTEM DIAGRAMS

PUMP & MOTOR SOLENOID OPERATION

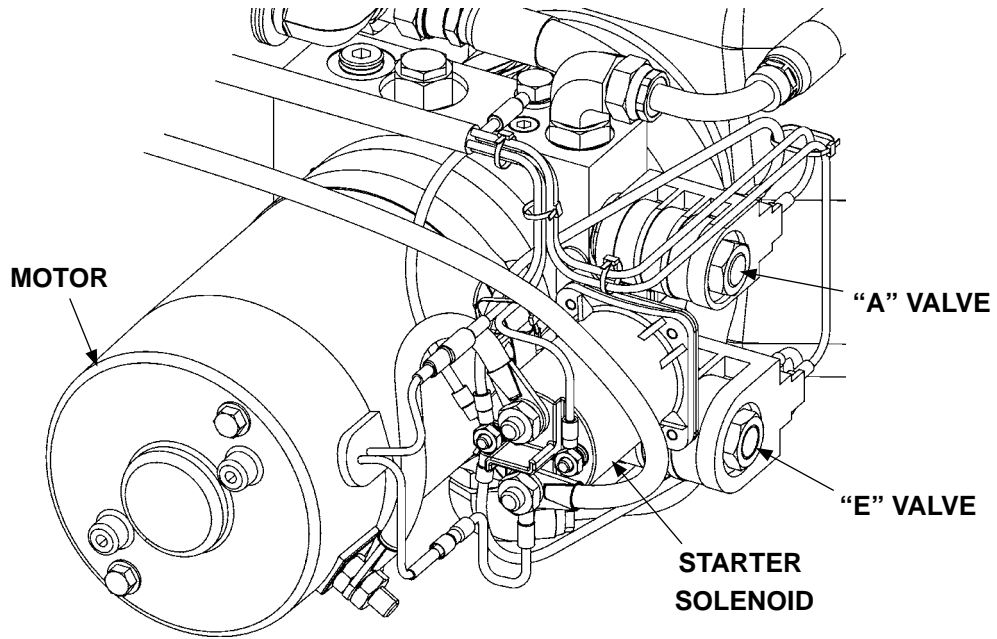

POWER UNIT
FIG. 47-1

| POWER UNIT MOTOR & SOLENOID OPERATION | | | | |
|---|------|---|--------------|--------------|
| LIFTGATE FUNCTION | PORT | SOLENOID OPERATION (✓ MEANS ENERGIZED) | | |
| | | MOTOR | VALVE "A" | VALVE "E" |
| RAISE | A | ✓ | - | ✓ |
| LOWER | B | ✓ | ✓ | - |
| REFER TO VALVES SHOWN ON HYDRAULIC SCHEMATIC | | | | |

TABLE 47-1

SYSTEM DIAGRAMS - Continued

HYDRAULIC SCHEMATIC (POWER DOWN)

MAXON[®]

11921 Slauson Ave. Santa Fe Springs, CA. 90670 (800) 227-4116 FAX (888) 771-7713

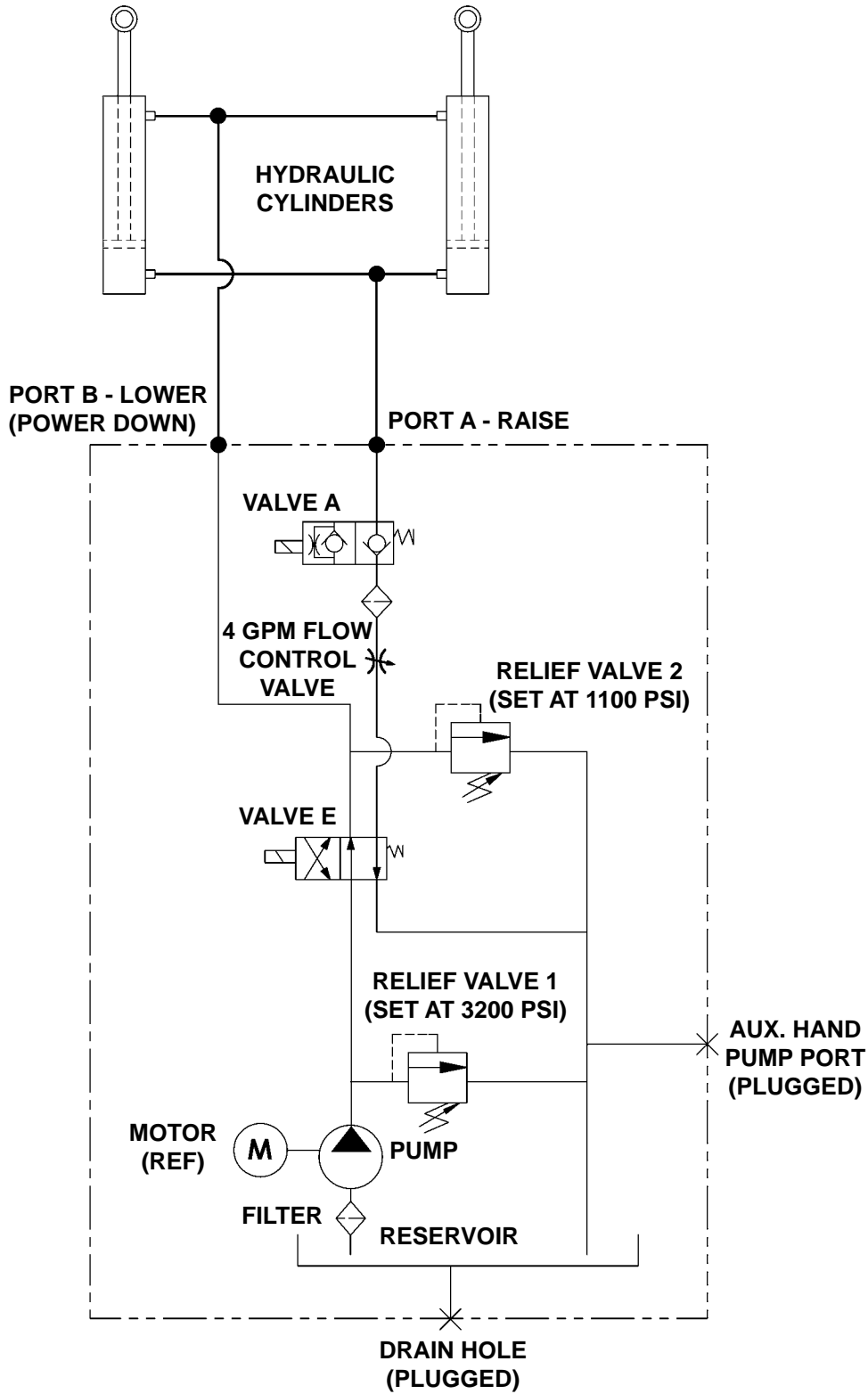

FIG. 48-1

ELECTRICAL SCHEMATIC (POWER DOWN)

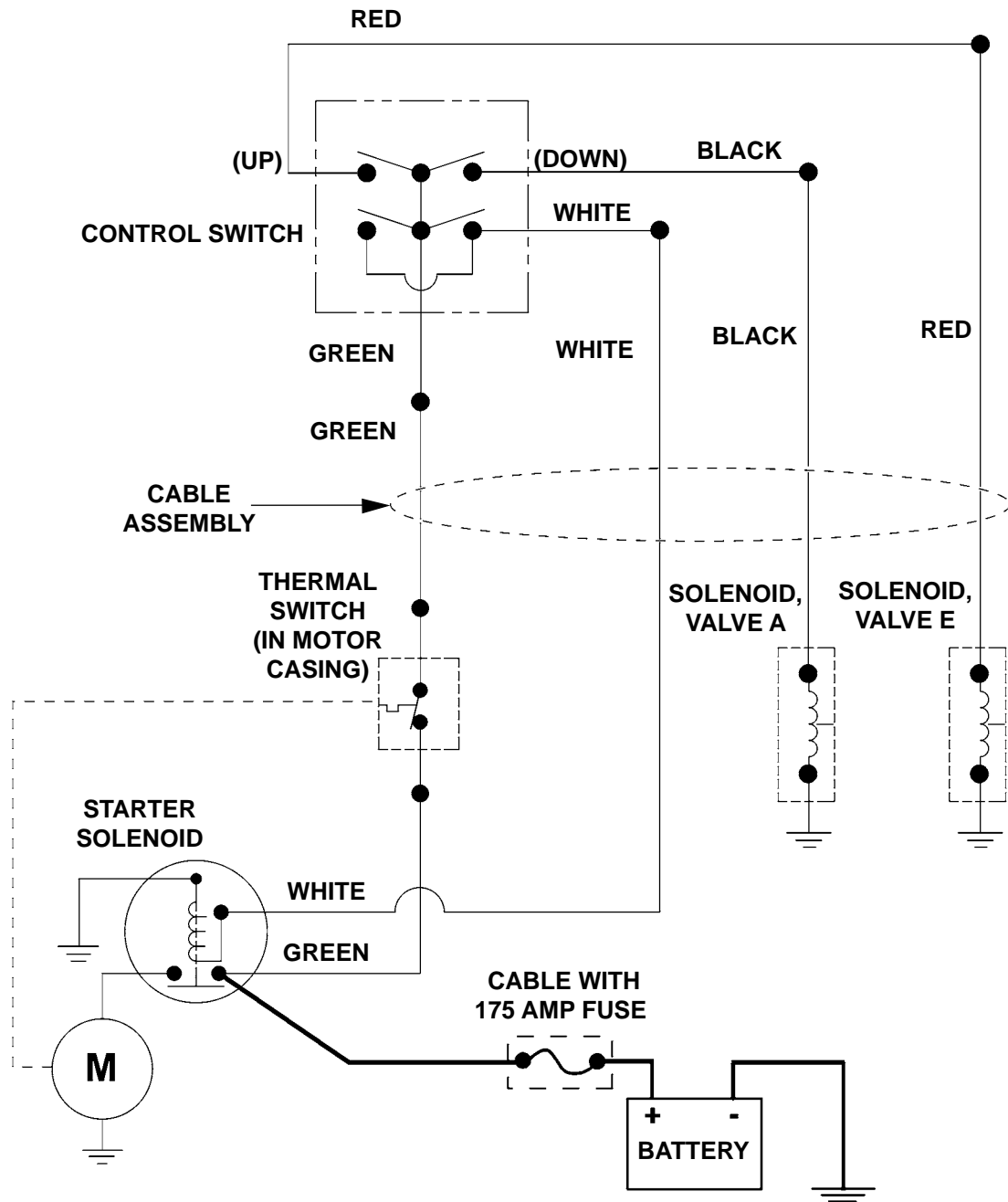

FIG. 49-1

TROUBLESHOOTING

PLATFORM WILL NOT RAISE & MOTOR WILL NOT RUN

1. Connect voltmeter between motor solenoid terminal “B” and ground wires connection on pump (FIG. 50-1). Verify that full battery voltage is at “B”. Recharge the battery if voltmeter indicates less than 12.6 volts dc.
2. Touch a jumper wire to terminals “B” & “D” (FIG. 50-1). If motor runs, check control switch, the switch connections, and white wire. Check and correct wiring connections or replace the control switch.
3. Touch heavy jumper cables to terminals “A” & “B” (FIG. 50-1).
 - a. If motor runs, replace the motor solenoid.
 - b. If motor does not run, repair or replace the pump motor.

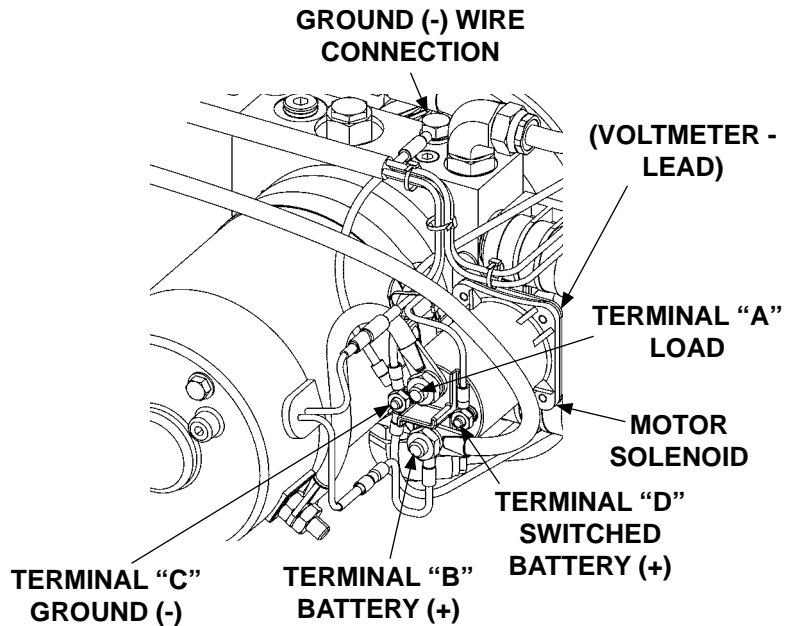

FIG. 50-1

PLATFORM WILL NOT RAISE, BUT MOTOR RUNS

1. Do the **CHECKING HYDRAULIC FLUID** procedure in this manual. If necessary, add hydraulic fluid.
2. Check for structural damage and replace worn parts.

CAUTION

Keep dirt, water and other contaminants from entering the hydraulic system. Before opening the hydraulic fluid reservoir filler cap, drain plug and hydraulic lines, clean up contaminants that can get in the openings. Also, protect the openings from accidental contamination during maintenance.

NOTE: In most cases, you can avoid having to manually bleed hydraulic system by correctly positioning Liftgate platform before disconnecting any lifting cylinder high pressure hydraulic lines.

3. Check pump oil filter in the reservoir (**FIG. 51-1**). Clean or replace filter, if necessary.

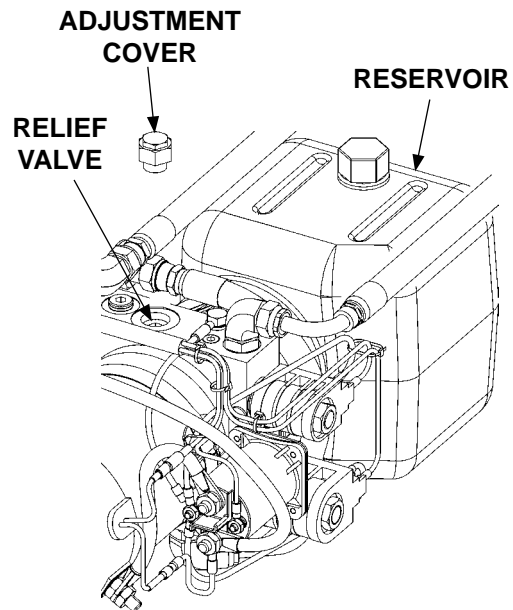

4. Check for dirty raising relief valve (**FIG. 51-1**). Clean or replace relief valve if necessary.

**CHECKING THE RAISING
RELIEF VALVE
FIG. 51-1**

PLATFORM RAISES BUT LEAKS DOWN

1. Check if the "A" (lowering) solenoid valve is constantly energized. Connect voltmeter negative (-) lead to ground (-) wires connection on pump and positive (+) lead to (+) terminal on the "A" (lowering) solenoid valve (**FIG. 52-1**). If voltmeter reads battery voltage, check for faulty wiring or toggle switch.

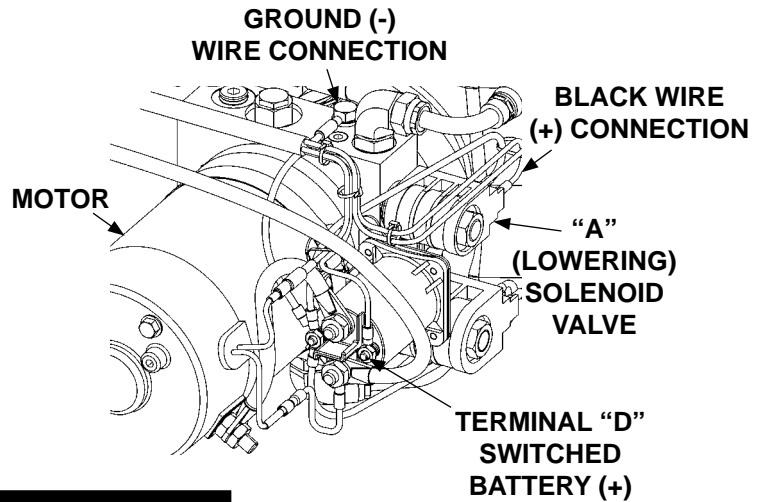

FIG. 52-1

CAUTION

Keep dirt, water and other contaminants from entering the hydraulic system. Before opening the hydraulic fluid reservoir filler cap, drain plug and hydraulic lines, clean up contaminants that can get in the openings. Also, protect the openings from accidental contamination during maintenance.

NOTE: In most cases, you can avoid having to manually bleed hydraulic system by correctly positioning Liftgate platform before disconnecting any lifting cylinder high pressure hydraulic lines.

2. Make sure platform is on the ground. Remove lowering solenoid valve (**FIG. 52-2**). Push on the plunger in the valve by inserting small screwdriver in the open end (**FIG. 52-3**). If the plunger does not move with a smooth, spring-loaded action (approximately 1/8"), replace the valve cartridge. Reinstall lowering solenoid valve. Torque valve cartridge to 30 lbs.-ft. and hex nut to 30 lbs.-in.

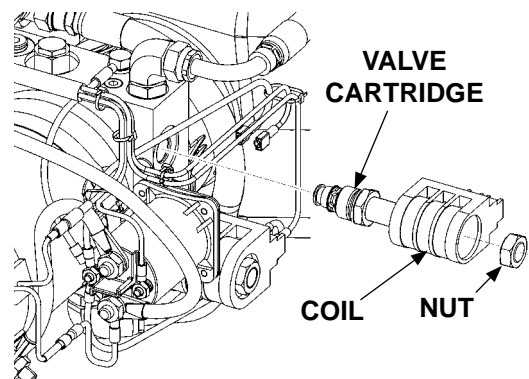

REMOVING SOLENOID VALVE
FIG. 52-2

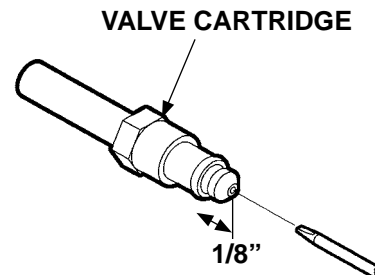

CHECKING SOLENOID VALVE
FIG. 52-3

3. Check the hydraulic cylinder. With the platform at vehicle floor level, remove the hydraulic line from the **LOWER** port on the cylinder (**FIG. 53-1**). Hold the control switch in the **UP** position for two seconds while you watch for hydraulic fluid at the **LOWER** port. A few drops of hydraulic fluid escaping the port is normal. However, if fluid streams out, piston seals are worn. Replace seals.

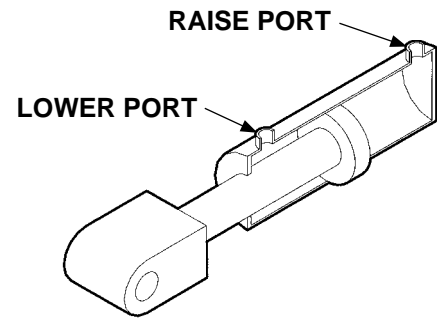

FIG. 53-1

PLATFORM RAISES PARTIALLY AND STOPS

1. Lower the opened platform to the ground. Do the **CHECKING HYDRAULIC FLUID** procedure in this manual. If necessary, add hydraulic fluid.
2. Use voltmeter to verify the battery voltage is 12.6 volts or more under load from pump motor.
3. Check for structural damage and poor lubrication. Replace worn parts.

CAUTION

Keep dirt, water and other contaminants from entering the hydraulic system. Before opening the hydraulic fluid reservoir filler cap, drain plug and hydraulic lines, clean up contaminants that can get in the openings. Also, protect the openings from accidental contamination during maintenance.

NOTE: In most cases, you can avoid having to manually bleed hydraulic system by correctly positioning Liftgate platform before disconnecting any lifting cylinder high pressure hydraulic lines.

4. Check for dirty raising relief valve (**FIG. 54-1**). Clean or replace relief valve, if necessary.
5. Check the hydraulic cylinder. With the platform at vehicle floor level, remove the hydraulic line from the **LOWER** port on the cylinder (**FIG. 54-2**). Hold the control switch in the **UP** position for two seconds while you watch for hydraulic fluid at the **LOWER** port. A few drops of hydraulic fluid escaping the port is normal. However, if fluid streams out, piston seals are worn. Replace seals.
6. Check pump oil filter in the reservoir (**FIG. 54-1**). Clean or replace filter, if necessary.

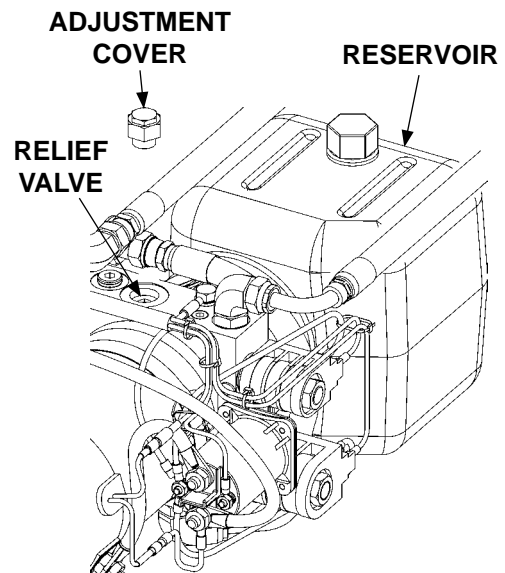

FIG. 54-1

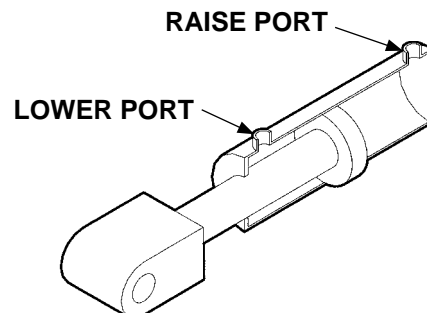

FIG. 54-2

LIFTGATE WILL NOT LIFT RATED CAPACITY

1. Use voltmeter to verify the battery voltage is 12.6 volts or more under load from pump motor.
2. Check for structural damage or lack of lubrication. Replace worn parts.

CAUTION

Keep dirt, water and other contaminants from entering the hydraulic system. Before opening the hydraulic fluid reservoir filler cap, drain plug and hydraulic lines, clean up contaminants that can get in the openings. Also, protect the openings from accidental contamination during maintenance.

NOTE: In most cases, you can avoid having to manually bleed hydraulic system by correctly positioning Liftgate platform before disconnecting any lifting cylinder high pressure hydraulic lines.

3. Check the 3200 PSI relief valve as follows. With platform on the ground, remove plug from hand pump port (**FIG. 55-1**). Install 0-4000 PSI pressure gauge in the hand pump port (**FIG. 55-1**). Remove cover for access to relief valve. Hold the control switch in the **UP** position. Adjust the relief valve until the gauge reads 3200 PSI (**FIG. 55-1**). Remove gauge and reinstall plug in the port. Then, reinstall relief valve cover.
4. Check if pump relief valve is dirty. Clean or replace relief valve, if necessary.
5. Check the hydraulic cylinder. With the platform at vehicle floor level, remove the hydraulic line from the **LOWER** port on the cylinder (**FIG. 55-2**). Hold the control switch in the **UP** position for two seconds while you watch for hydraulic fluid at the **LOWER** port. A few drops of hydraulic fluid escaping the port is normal. However, if fluid streams out, piston seals are worn. Replace seals.
6. If pump cannot produce 3200 PSI or lift the load capacity with a minimum of 12.6 volts available, the pump is worn and needs to be replaced.

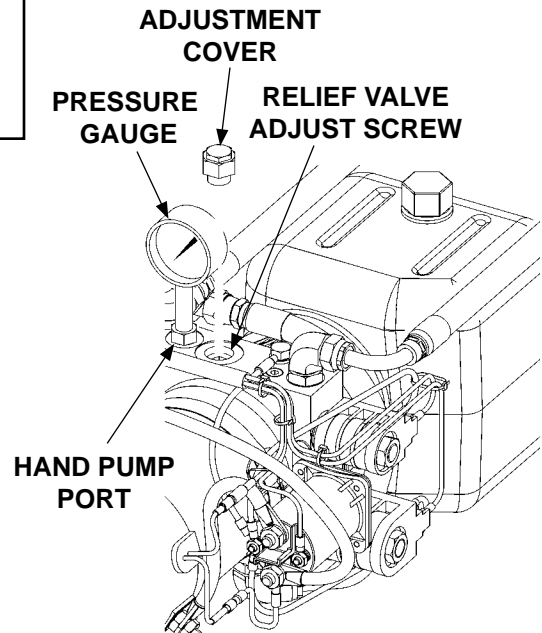

FIG. 55-1

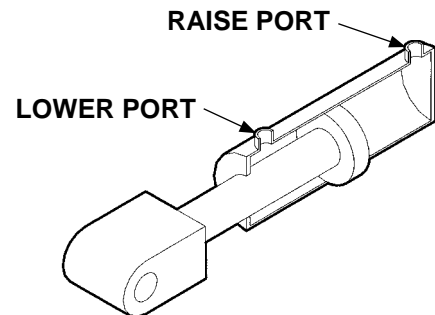

FIG. 55-2

PLATFORM RAISES SLOWLY

1. Connect voltmeter between motor solenoid terminal "B" and ground (-) wires connection on pump (FIG. 56-1). Verify that full battery voltage is at "B". Recharge the battery if voltmeter indicates less than 12.6 volts dc.

CAUTION

Keep dirt, water and other contaminants from entering the hydraulic system. Before opening the hydraulic fluid reservoir filler cap, drain plug and hydraulic lines, clean up contaminants that can get in the openings. Also, protect the openings from accidental contamination during maintenance.

NOTE: In most cases, you can avoid having to manually bleed hydraulic system by correctly positioning Liftgate platform before disconnecting any lifting cylinder high pressure hydraulic lines.

2. Check the hydraulic cylinder. With the platform at vehicle floor level, remove the hydraulic line from the **LOWER** port on the cylinder (FIG. 56-2). Hold the control switch in the **UP** position for two seconds while you watch for hydraulic fluid at the **LOWER** port. A few drops of hydraulic fluid escaping the port is normal. However, if fluid streams out, piston seals are worn. Replace seals.

CAUTION

To prevent damage to flow control valve, do not disassemble the valve.

3. Check the flow control valve as follows. Remove lowering solenoid valve and flow control valve (FIG. 56-3). Ensure the flow control valve operates with a smooth spring-loaded action. Check for debris inside the valve. Clean or replace the flow control valve, if necessary. Reinstall flow control valve (if good) or a replacement. Then, reinstall the lowering solenoid valve. **Reinstall lowering solenoid valve. Torque valve cartridge to 30 lbs.-ft. and hex nut to 30 lbs.-in.**

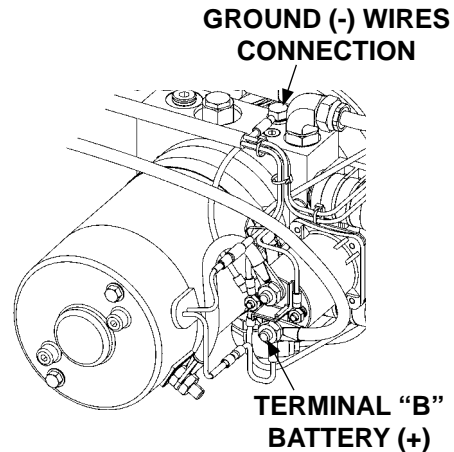

FIG. 56-1

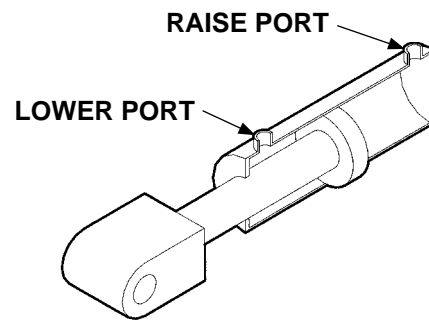

FIG. 56-2

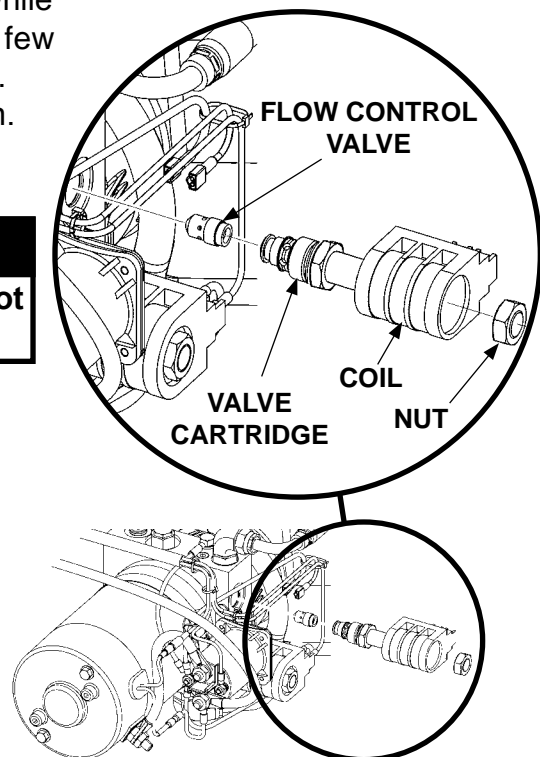

FIG. 56-3

4. Verify the pump motor is grounded to vehicle frame.
5. Check for leaking hoses and fittings. Tighten or replace as required.
6. Check for structural damage and poor lubrication. Replace worn parts.
7. Check pump oil filter in the reservoir **(FIG. 57-1)**. Clean or replace filter, if necessary.

8. Check the 3200 PSI relief valve as follows. With platform on the ground, remove plug from hand pump port **(FIG. 57-1)**. Install 0-4000 PSI pressure gauge in the hand pump port **(FIG. 57-1)**. Remove cover for access to relief valve. Hold the control switch in the **UP** position. Adjust the relief valve until the gauge reads 3200 PSI **(FIG. 57-1)**. Remove gauge and reinstall plug in the port. Then, reinstall relief valve cover.

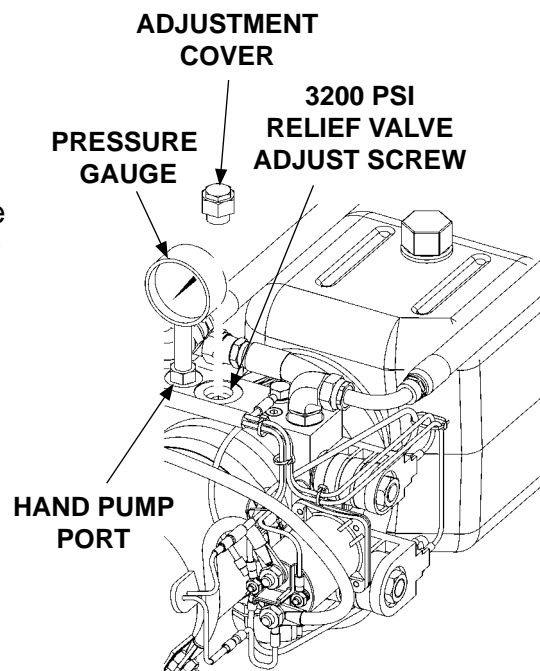

FIG. 57-1

PLATFORM WILL NOT LOWER, LOWERS TOO SLOWLY OR TOO QUICKLY

1. Connect voltmeter (+) lead to motor solenoid terminal “B” and the (-) lead to the ground wires connection on pump (**FIG. 58-1**). Verify that full battery voltage is at “B”. Recharge the battery if voltmeter indicates less than 12.6 volts dc.

2. Check for structural damage or poor lubrication. Replace worn parts.

3. Check if the “D” terminal and “A” (lowering) solenoid valve are getting battery voltage (**FIG. 58-1**). Connect voltmeter negative (-) lead to ground (-) wires connection on pump and positive (+) lead to the “D” terminal (**FIG. 58-1**). Hold control switch in the **DOWN** position. Then, connect voltmeter (+) lead to (+) terminal on the “A” (lowering) solenoid valve (**FIG. 58-1**). If voltmeter shows a much lower reading than +12.6 volts dc or a reading of 0 volts, check for faulty control switch and wiring, battery cable, ground wire connections in pump assembly, and pump motor.

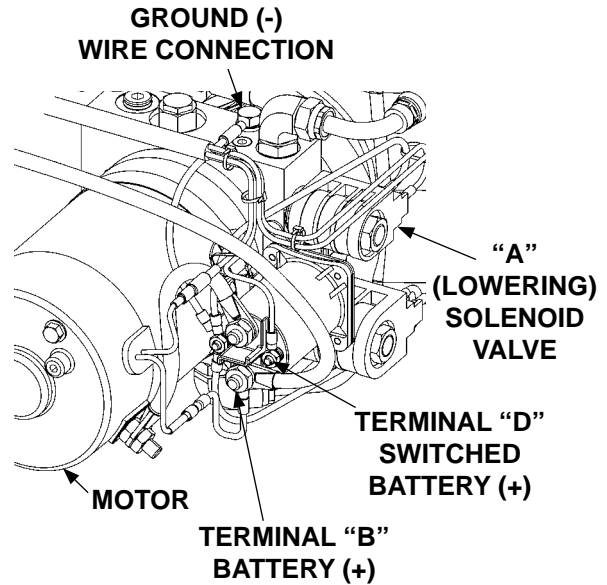

FIG. 58-1

MAXON[®]

11921 Slauson Ave. Santa Fe Springs, CA. 90670 (800) 227-4116 FAX (888) 771-7713

CAUTION

Keep dirt, water and other contaminants from entering the hydraulic system. Before opening the hydraulic fluid reservoir filler cap, drain plug and hydraulic lines, clean up contaminants that can get in the openings. Also, protect the openings from accidental contamination during maintenance.

NOTE: In most cases, you can avoid having to manually bleed hydraulic system by correctly positioning Liftgate platform before disconnecting any lifting cylinder high pressure hydraulic lines.

4. Make sure platform is on the ground. Check the flow control valve as follows. Remove lowering solenoid valve and flow control valve (**FIG. 59-1**). Ensure the flow control valve operates with a smooth spring-loaded action. Check for debris inside the valve. Clean or replace the flow control valve, if necessary. Reinstall flow control valve (if good) or a replacement.

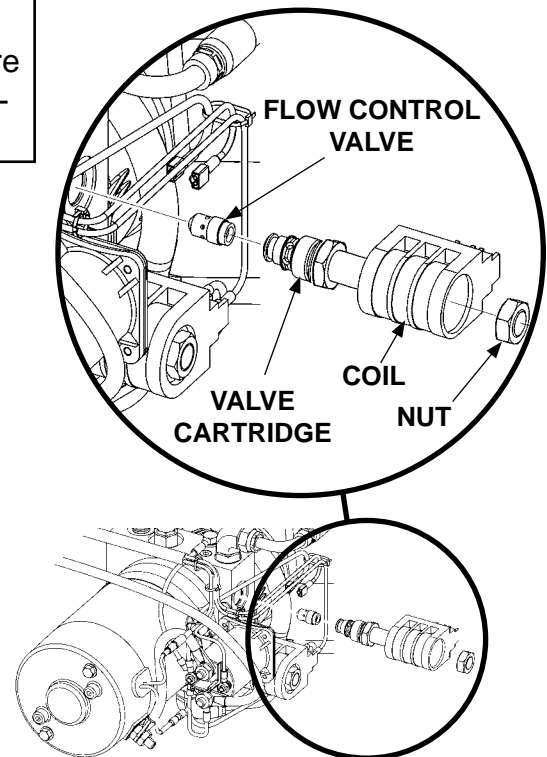
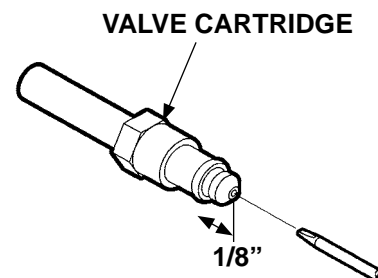

FIG. 59-1

CAUTION

To prevent damage to flow control valve, do not disassemble the valve.

5. Check the lowering solenoid valve as follows. Check if filtering screen is plugged. Clean carefully if required. Push on the plunger in the valve by inserting small screwdriver in the open end (**FIG. 59-1**). If the plunger does not move with a smooth, spring-loaded action (approximately 1/8"), replace the valve cartridge. Reinstall lowering solenoid valve (if good) or a replacement. Torque valve cartridge to 30 lbs.-ft. and hex nut to 30 lbs.-in.



CHECKING SOLENOID VALVE
FIG. 59-2

PLATFORM WILL NOT TILT DOWN TO THE GROUND

NOTE: If the Liftgate is not damaged, the 1100 psi (lowering) pressure relief valve in the pump may need to be adjusted as follows.

1. Unhook safety chain. Lower the platform until shackles touch the ground (**FIG. 60-1**).

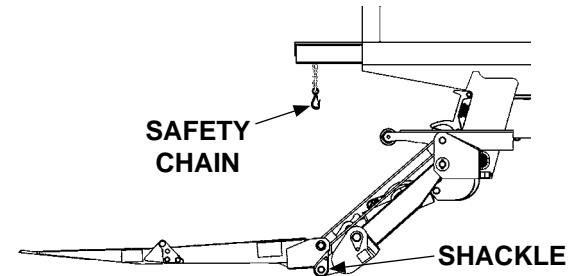

PLATFORM LOWERED WITH SHACKLES TOUCHING THE GROUND

FIG. 60-1

2. Unbolt and remove pump cover (**FIG. 60-2**).

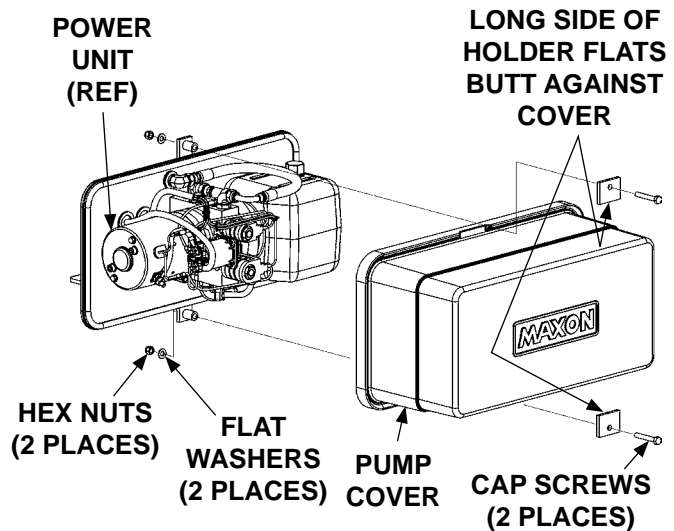

UNBOLTING PUMP COVER

FIG. 60-2

MAXON[®]

11921 Slauson Ave. Santa Fe Springs, CA. 90670 (800) 227-4116 FAX (888) 771-7713

- Adjust the 1100 PSI relief valve as follows. With platform on the ground, remove plug from hand pump port (**FIG. 61-1**). Install 3000 PSI pressure gauge in the hand pump port (**FIG. 61-1**). Remove cover for access to relief valve. Hold the control switch in the **DOWN** position. Adjust the relief valve until the gauge reads 1100 PSI (**FIG. 61-1**). Remove gauge and reinstall plug in the port. Then, reinstall relief valve cover.

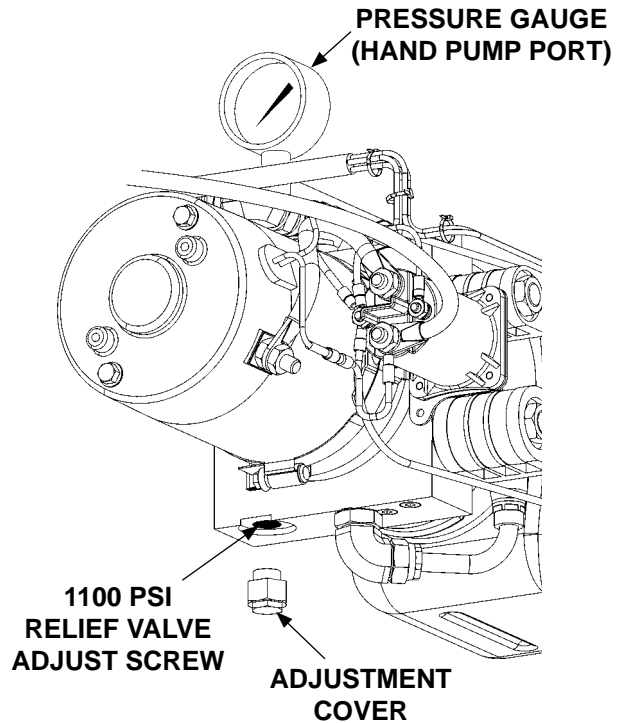

**ADJUSTING RELIEF VALVE
FIG. 61-1**

CAUTION
 Pump cover must be correctly secured to prevent it from becoming a hazard. To secure pump cover, the long side of the holder flats must butt against pump cover as shown in the illustration.

- Bolt on the pump cover as shown in **FIG. 61-2**. Torque the 5/16"-18 cover bolts from **10 to 14 lbs.-ft.**

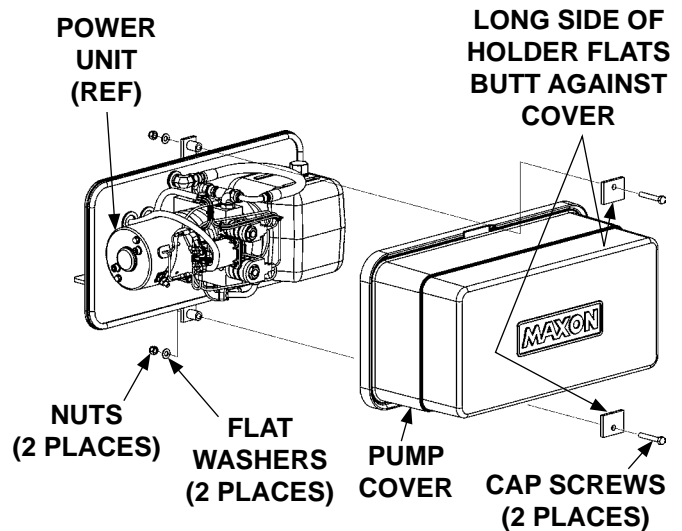

**BOLTING ON PUMP COVER
FIG. 61-2**

