

# MAXON®

M-99-49  
REV. H  
FEBRUARY 2004

## INSTALLATION **GPT** MANUAL **GPT**

- GPT-25
- GPT- 3
- GPT- 4
- GPT- 5

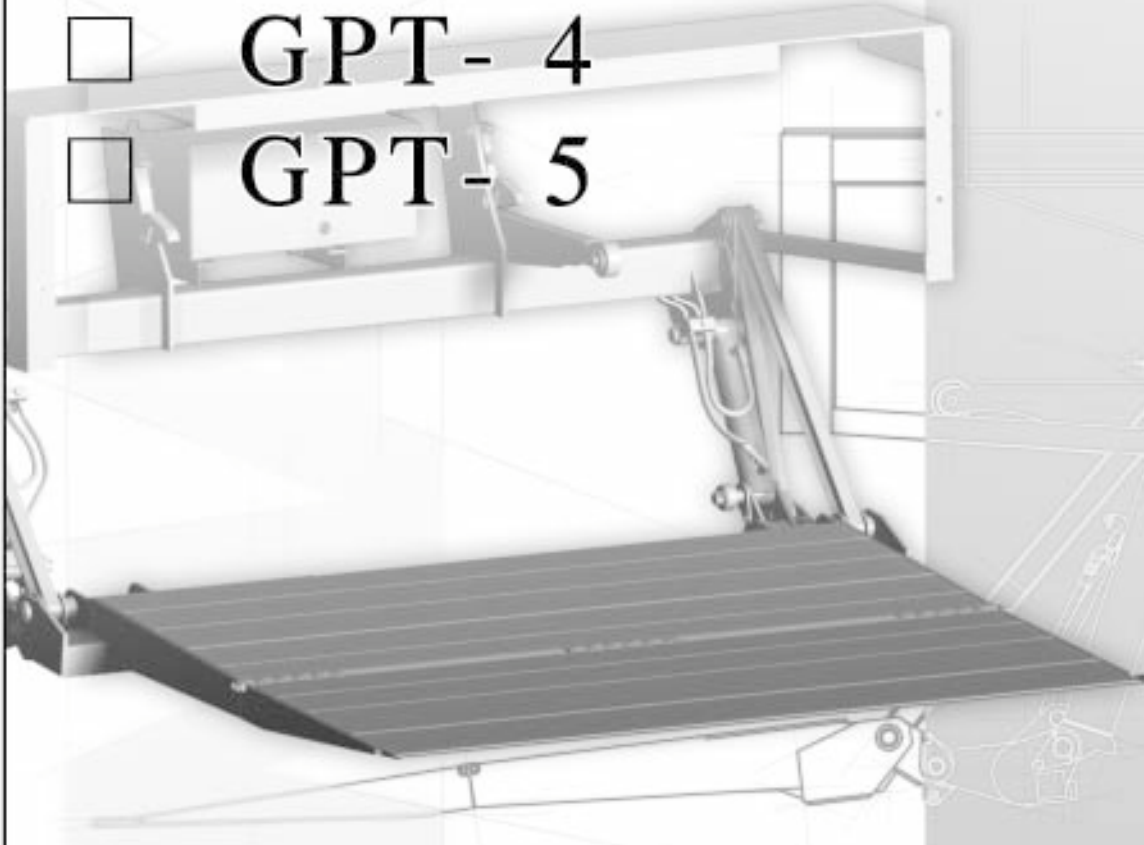

# TABLE OF CONTENTS

<b>WARNINGS</b> .....	<b>3</b>
STANDARD LIFTGATE COMPONENTS .....	4
GPT-SERIES INSTALLATION PARTS BAGS .....	5
STEP 1 - PREPARE VEHICLE .....	6
STEP 2 - WELD EXTENSION PLATE TO VEHICLE .....	8
STEP 3 - WELD LIFTGATE TO VEHICLE .....	10
STEP 4 - RUN POWER CABLE .....	14
STEP 5 - CONNECT POWER CABLE .....	15
STEP 6 - INSTALL CONTROL SWITCH .....	16
STEP 7 - CONNECT POWER CABLE TO BATTERY .....	18
STEP 8 - REMOVE LOCKING ANGLES & WELDS .....	19
STEP 9 - WELD PLATFORM OPENER TO LIFTGATE .....	20
STEP 10 - FINISH WELDING LIFTGATE TO VEHICLE .....	23
STEP 11 - INSTALL & ADJUST SADDLES .....	24
STEP 12 - CHECK HYDRAULIC FLUID .....	25
STEP 13 - WELD HOOK AND EYE TO LIFTGATE .....	26
STEP 14 - WELD DOCK BUMPERS TO LIFTGATE .....	27
STEP 15 - BOLT RUBBER BUMPERS TO LIFTGATE .....	28
STEP 16 - PLACE DECALS .....	29
STEP 17 - VEHICLE TAILLIGHT POSITIONING .....	31
<b>HYDRAULIC SYSTEM SCHEMATIC</b> .....	<b>32</b>
<b>ELECTRICAL SYSTEM SCHEMATIC</b> .....	<b>33</b>
<b>OPTIONS</b> .....	<b>34</b>
OPTIONAL LIFTGATE COMPONENTS.....	34
RECOMMENDED LIFTGATE POWER CONFIGURATION .....	35

Comply with the following **WARNINGS** while installing Liftgates. See Operation Manual M-97-16 for operating safety requirements.

## **▲ WARNING**

- Read and understand the instructions in this **Installation Manual** before installing Liftgate.
- Before operating the Liftgate, read and understand the operating instructions in **Operation Manual M-97-16**.
- Comply with all **WARNING** and instruction decals attached to the Liftgate.
- Keep decals clean and legible. If decals are defaced or missing, replace them. Free replacement decals are available from **Maxon Customer Service**.
- Consider the safety and location of bystanders and location of nearby objects when operating the Liftgate. Stand to one side of the platform while operating the Liftgate
- Do not allow untrained persons to operate the Liftgate.
- Do not stand under, or allow obstructions under the platform when lowering the Liftgate. **Be sure your feet are clear of the Liftgate.**
- **Keep fingers, hands, arms, legs, and feet clear of moving Liftgate parts (and platform edges) when operating the Liftgate.**
- **Correctly stow platform when not in use. Extended platforms could create a hazard for people and vehicles passing by.**
- **Make sure vehicle battery power is disconnected** while installing Liftgate. Connect vehicle battery power to the Liftgate only when installation is complete or as required in the installation instructions.
- Wear appropriate safety equipment such as protective eyeglasses, faceshield and clothing while performing maintenance on the Liftgate and handling the battery. Debris from drilling and contact with battery acid may injure unprotected eyes and skin.
- Be careful working by an automotive type battery. Make sure the work area is well ventilated and there are no flames or sparks near the battery. Never lay objects on the battery that can short the terminals together. If battery acid gets in your eyes, immediately seek first aid. If acid gets on your skin, immediately wash it off with soap and water.
- If an emergency situation arises (vehicle or Liftgate) while operating the Liftgate, release the control Toggle Switch and the Liftgate will stop.
- A correctly installed Liftgate operates smoothly and reasonably quiet. The only noticeable noise during operation comes from the pump unit while the platform is raised and lowered. Listen for scraping, grating and binding noises and correct the problem before continuing to operate Liftgate.
- If it is necessary to stand on the platform while operating the Liftgate, keep your feet and any objects clear of the inboard edge of the platform. Your feet or objects on the platform could be trapped between the platform and the Liftgate extension plate.
- Never perform unauthorized modifications on the Liftgate. Modifications may result in early failure of the Liftgate and may create hazards for Liftgate operators and maintainers.

# STANDARD LIFTGATE COMPONENTS

## ⚠ CAUTION

Prevent injuries and equipment damage. Before cutting the shipping straps from the Liftgate, put Liftgate on level ground that will support at least 1500 pounds. Be careful lifting and moving components (such as Extension Plate) after shipping straps are removed.

**NOTE:** Make sure you have all components and parts before you start installing Liftgate. Compare parts in the Part Box and each Kit Box with packing list enclosed in each box. If parts and components are missing or incorrect call:

**Maxon Customer Service**

Call (800) 227-4116 or

Send e-mail to [customersupport@maxonlift.com](mailto:customersupport@maxonlift.com)

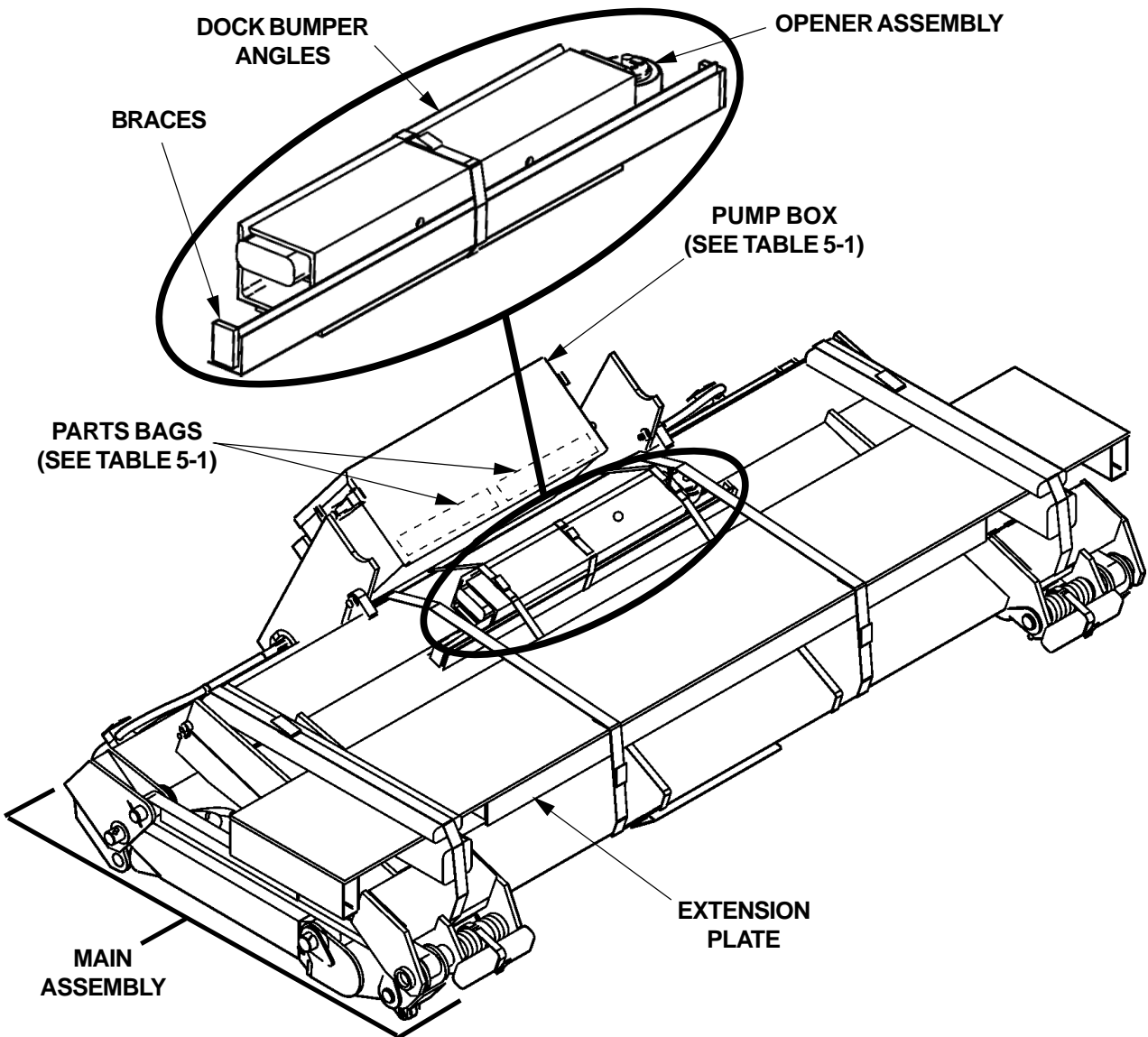

TYPICAL LIFTGATE PACKAGED FOR SHIPMENT

FIG. 4-1

## GPT-SERIES INSTALLATION PARTS BAGS

	PARTS BOX CONTENTS	QTY.	PART NUMBER
1.	FLAT, 2-1/2" X 1" X 1/8"	2	201999
2.	KIT, RUBBER DOCK BUMPER	1	203410
3.	COPPER LUG (#2 GA)	1	226778
4.	FUSED POWER CABLE, 200 AMP, 38' LG.	1	264422
5.	EYE, DROP FORGED PAD, 3/4" X 1-1/2"	1	226938
6.	HEATSHRINK TUBING, 5/8" I.D. X 1-1/2" LG.	1	253316-04
7.	HOOK ASSY	1	227700
8.	SWITCH AND CABLE ASSY	1	264346
9.	SHIM, 3-1/2" X 1-3/4" X 1/4"	2	264731
10.	SHIM, 2-1/2" X 1" X 1/16"	2	264732
11.	FLAT, 5" X 4" X 3/8"	2	229295
12.	DECAL & MANUALS KIT	1	-
	A. OPERATION MANUAL	1	M-97-16
	B. INSTALLATION MANUAL	1	M-99-49
	C. MAINTENANCE MANUAL	1	M-97-15
	D. WARRANTY CARD	1	M-78-78
	E. CUSTOMER SURVEY FORM	1	M-94-04
	F. DECALS	-	<b>REFER TO DECAL PAGES IN THIS MANUAL.</b>
13.	CLAMP, #10 RUBBER LOOM	2	801681
14.	SELF-TAPPING SCREW 10-24 X 1"	4	900057-5
15.	FRAME CLIP, 1/2" X 1-3/8"	7	050079
16.	SADDLE	2	265849-01
17.	LOCK NUT, FLANGED, 1/2"-13	4	901023
18.	HEX BOLT, FRAME, 1/2"-13, 2-1/4" LG, GRADE 8	4	901024-3

**TABLE 5-1**

# STEP 1 - PREPARE VEHICLE

**NOTE: BODY Maximum and Minimum Operating Bed Height:**  
**For GPT-25, GPT-3, GPT-4, & GPT-5 With Standard Platform -**  
 Maximum height is **55"** (Unloaded). Minimum height is **46"** (Loaded).  
 On Vehicle Bodies equipped with swing open doors, the Extension Plate and Vehicle Body must be modified to install this Liftgate.

**NOTE:** Make sure vehicle is parked on level ground while preparing Vehicle and installing Liftgate.

1. Check for correct clearances (**FIG. 6-1** and **FIG. 6-2**) on vehicle to prevent interference between vehicle and Liftgate.

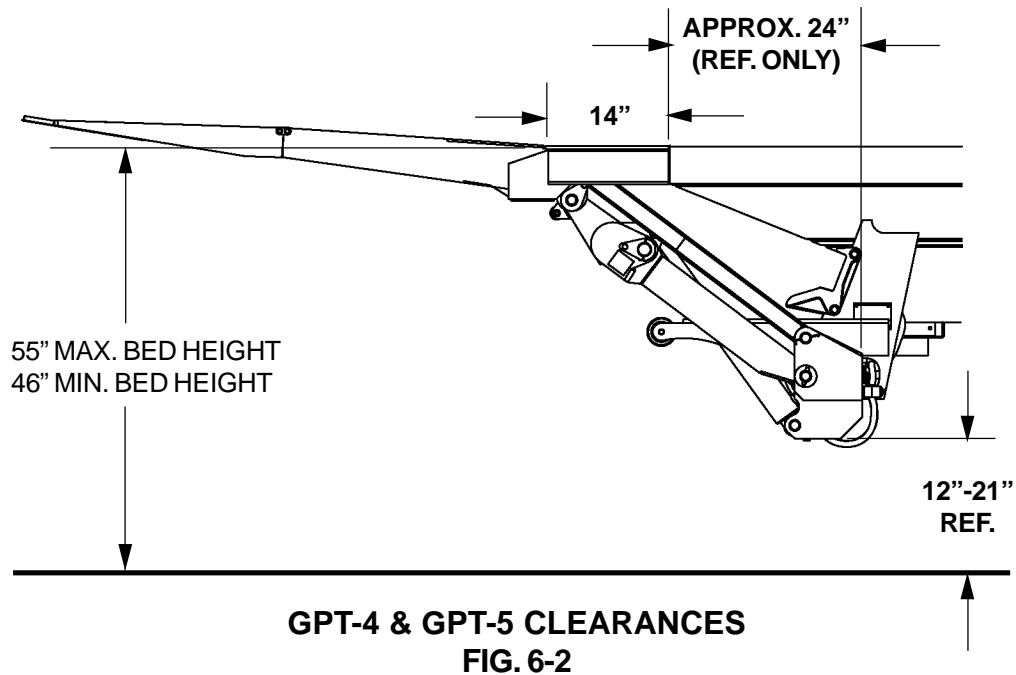
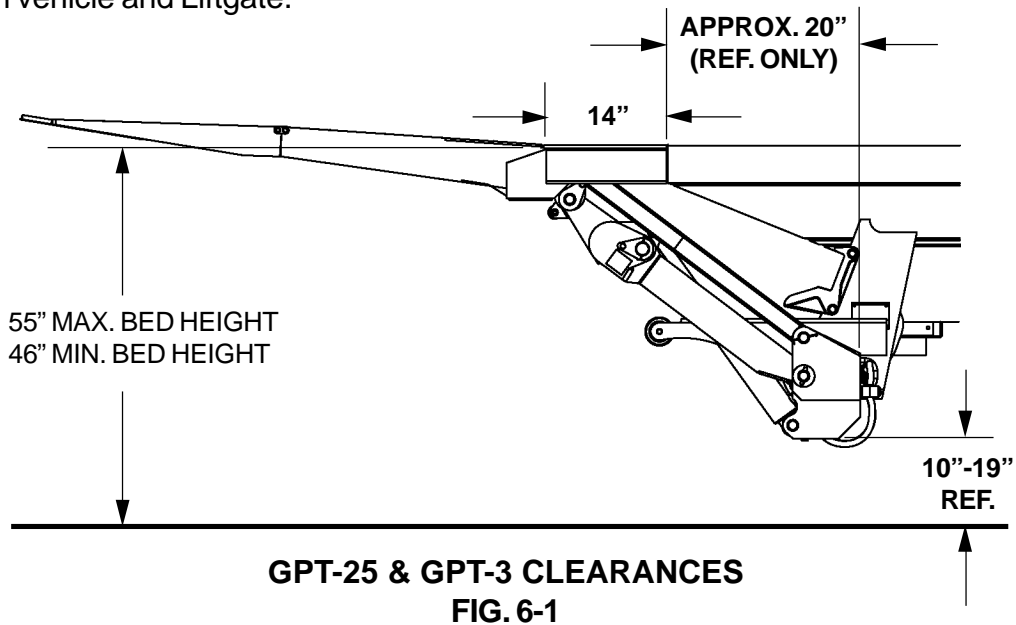

## STEP 1 PREPARE VEHICLE - Continued

### CAUTION

To prevent Aluminum Platform from being damaged, make sure Truck Frame is cut correctly as shown in the illustration below. If the Frame is cut incorrectly, Platform may hit the Truck Frame while stowing Liftgate.

**NOTE:** If installing Liftgate on a trailer, skip frame cutting instructions in Item 2.

2. Fit Liftgate to a truck body by cutting the truck frame members as shown in **FIG. 7-1**.

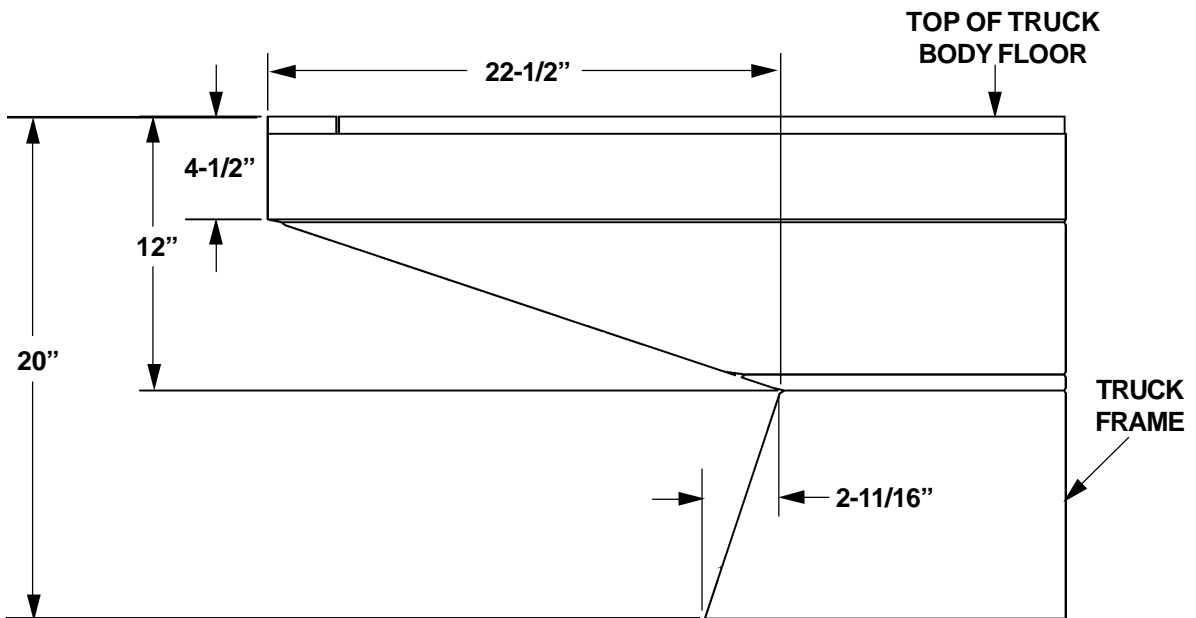

CUTS FOR GPT-25, GPT-3, GPT-4 & GPT-5  
FIG. 7-1

## STEP 2 - WELD EXTENSION PLATE TO VEHICLE

1. Center the Extension Plate on vehicle body. Before welding Extension Plate to vehicle body, make sure top surface of Extension Plate is flush with floor of vehicle body. Weld the Extension Plate to vehicle body sill as shown in **FIG. 8-1** and **FIG. 8-2**.

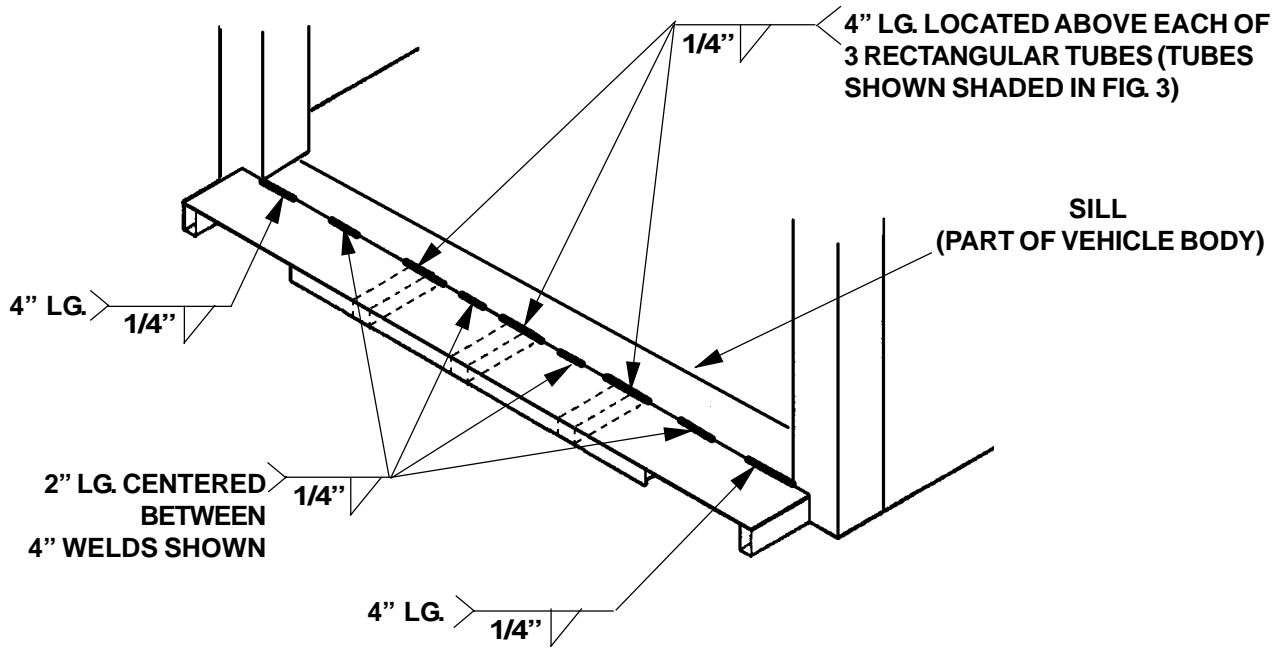

**EXTENSION PLATE WELDS - VIEWED FROM ABOVE  
FIG. 8-1**

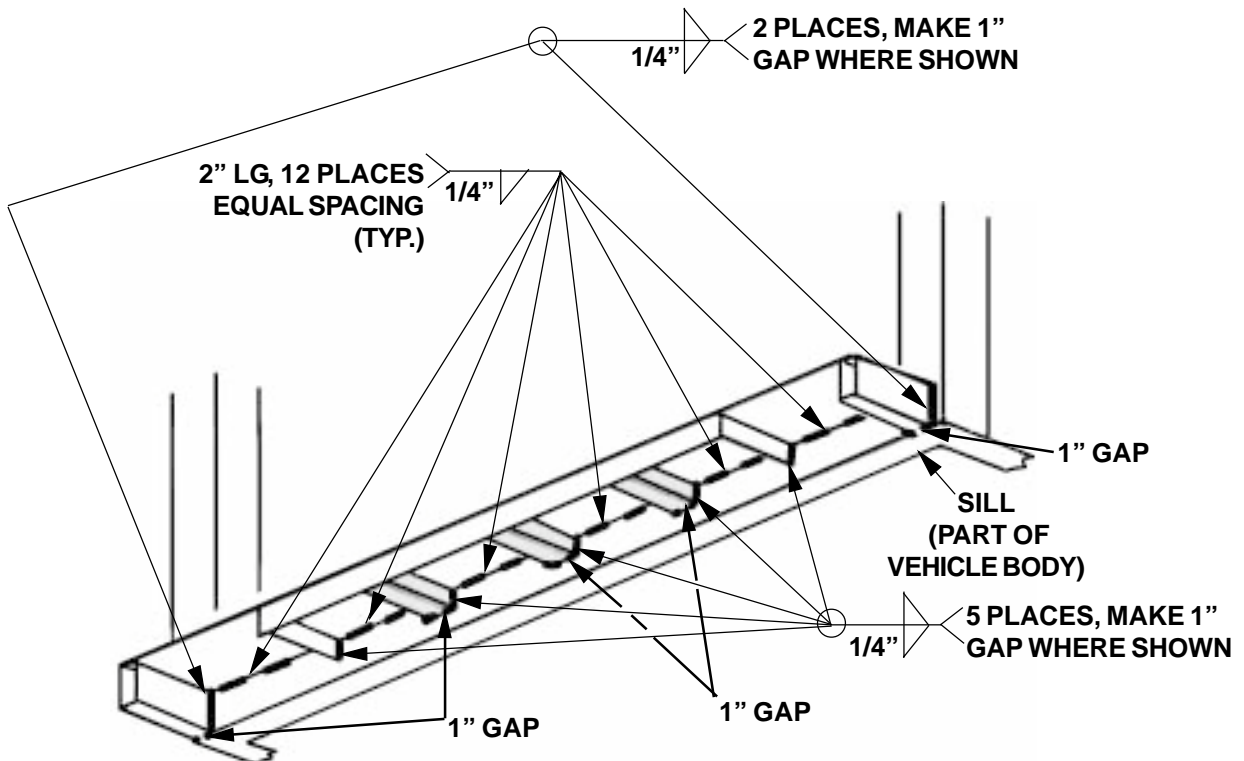

**EXTENSION PLATE WELDS - VIEWED FROM UNDERNEATH  
FIG. 8-2**



## STEP 2 - WELD EXTENSION PLATE TO VEHICLE - Continued

2. Place 2 temporary Support Straps (5" x 4" x 3/8" flats from Parts Box) on the Extension Plate as shown in **FIG. 9-1A**. Also, put 2 temporary spacers (2" x 1" x 1/8" flats from Parts Box) between Platform and Extension Plate as shown in **FIG. 9-1B**. (Spacers keep 1/8" between Platform and Extension Plate while welding liftgate to vehicle frame.) Weld the Straps and Spacers to Extension Plate (**FIG. 9-1B**).

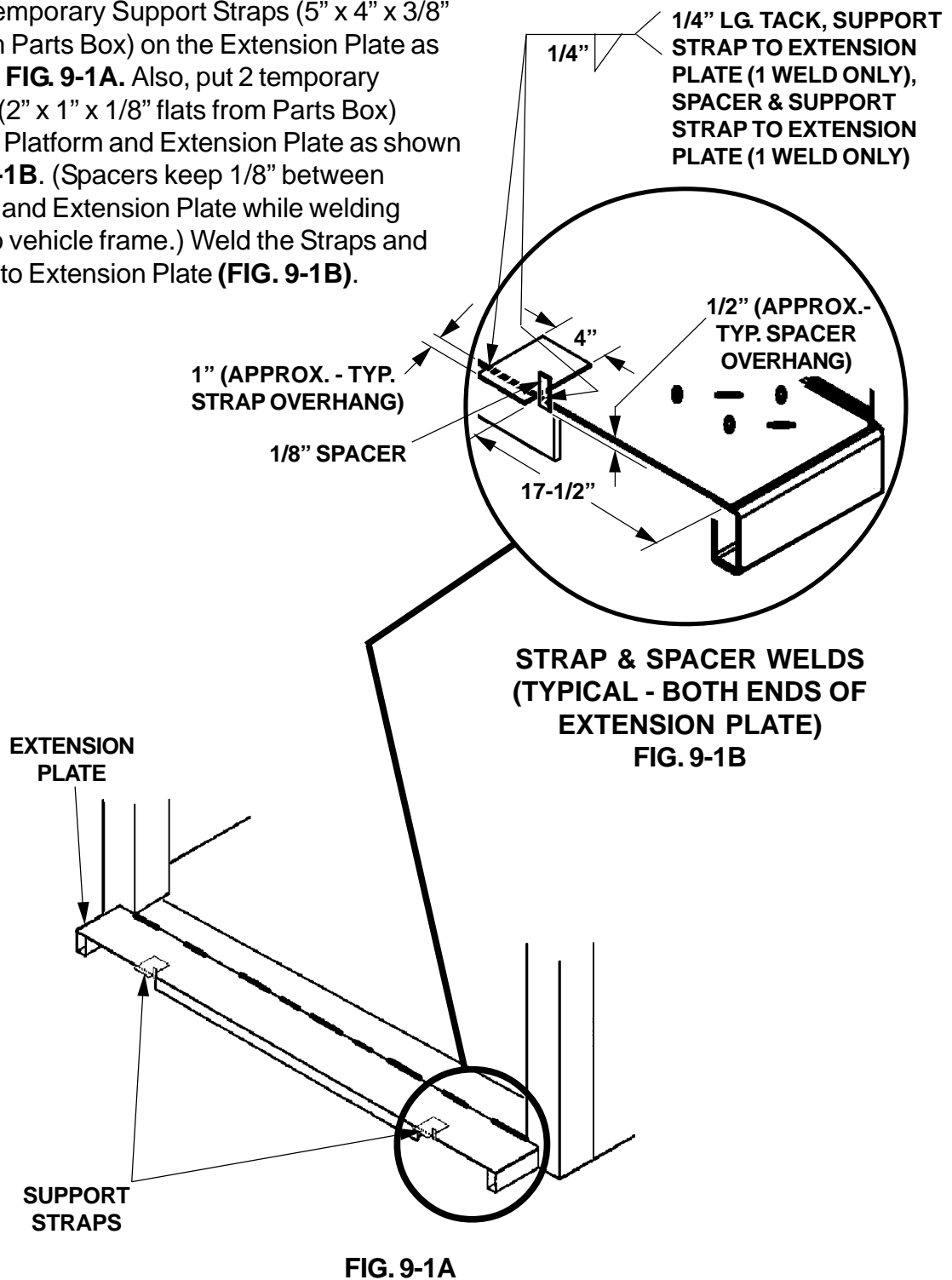

## STEP 3 - WELD LIFTGATE TO VEHICLE

1. Remove Split Looms from Mounting Plates (FIGS. 10-1A & 10-1B). (Split Looms will be reinstalled later after final welding).

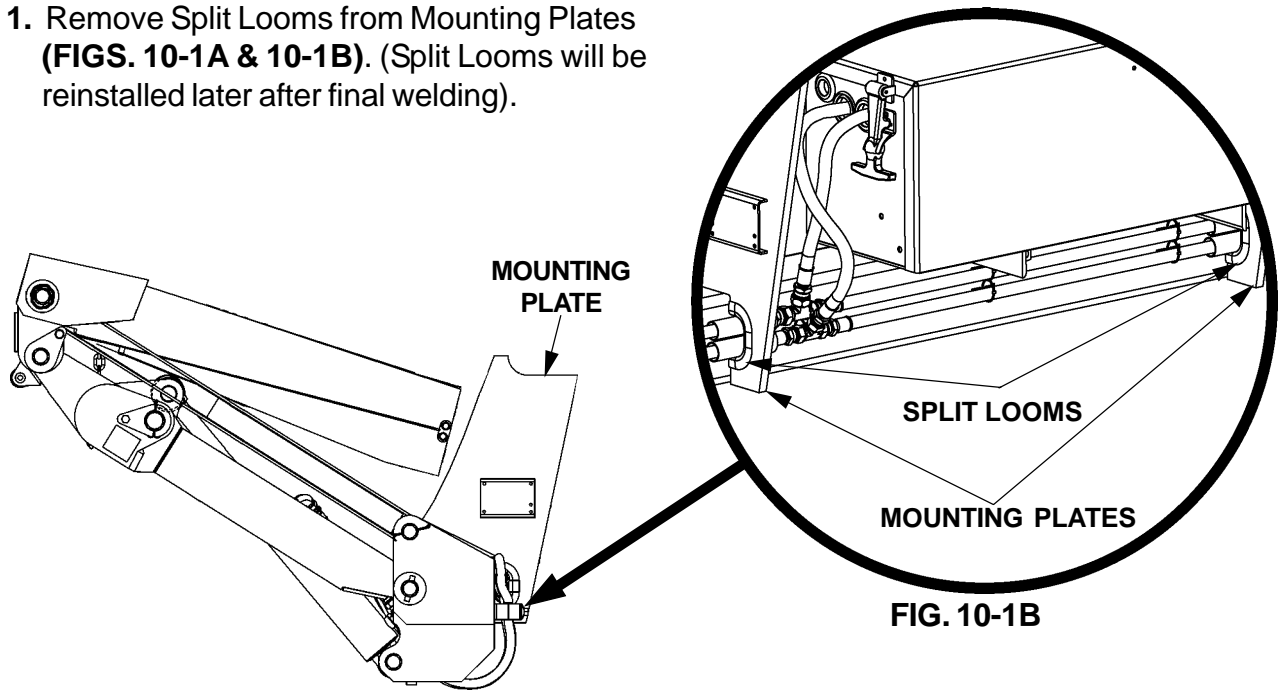

RH SIDE VIEW OF LIFTGATE  
FIG. 10-1A

2. Unfold the Platform and Flipover (FIG. 10-2).

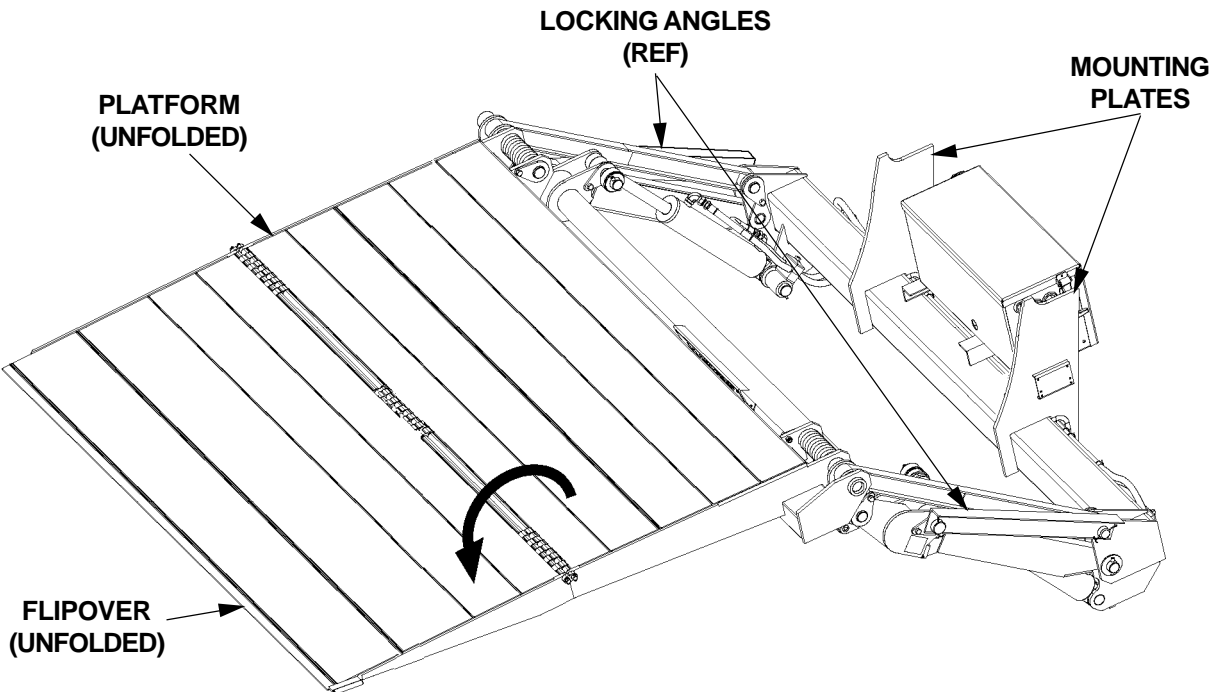

PLATFORM & FLIPOVER UNFOLDED  
FIG. 10-2

## STEP 3 - WELD LIFTGATE TO VEHICLE - Continued

### ⚠ CAUTION

To prevent damage to Aluminum Flip Over, NEVER hoist the Liftgate by the Flipover as shown in the NO illustration. Hoist the Liftgate by the Platform only as shown in the YES illustration.

3. Make sure Hoist will not be set up the incorrect way (FIG. 11-2). Place a "C"-Clamp on each side of Platform as shown in FIG. 11-1. (Clamps prevent Hoist Chain from slipping off Platform.) Place chain all around Platform (FIG. 11-1).

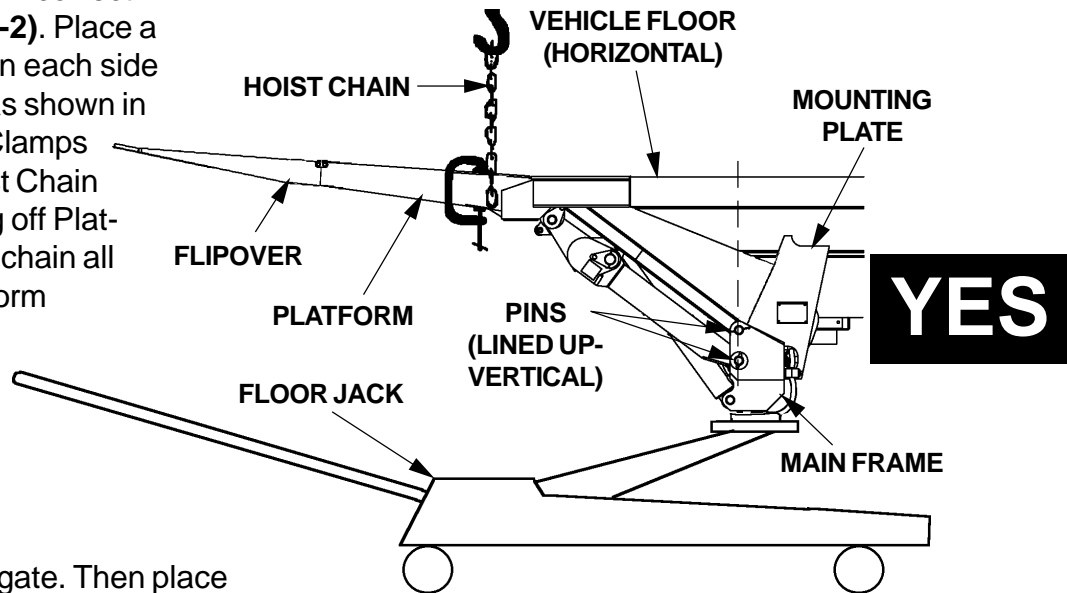

**CORRECT WAY TO HOIST LIFTGATE**  
FIG. 11-1

4. Hoist the Liftgate. Then place floor jack under Main Frame (FIG. 11-1). Jack the Liftgate in position. Make sure Vehicle Floor is horizontal and Pins are lined up (FIG. 11-1).

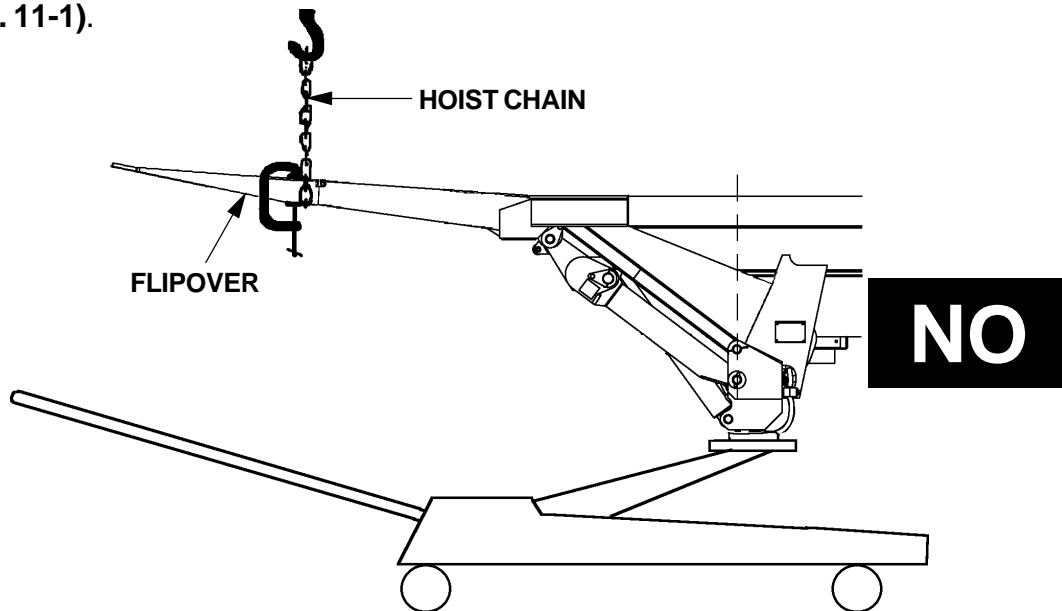

**INCORRECT WAY TO HOIST LIFTGATE**  
FIG. 11-2

## STEP 3 - WELD LIFTGATE TO VEHICLE - Continued

### ⚠ WARNING

Liftgate is shipped from factory with Mounting Plates that are only Tack Welded to Main Frame. Weld as shown in illustration before operating Liftgate.

### CAUTION

Prevent damaged hydraulic hoses. If welding next to hydraulic hoses, use a protective cover such as a welding blanket to cover the hoses.

5. Check if both Mounting Plates line up with the vehicle frame. If the Mounting Plates do not line up, remove the tack welds from one Mounting Plate (**FIG. 12-1**). Make sure Liftgate stays centered on vehicle. Reposition the Mounting Plate against vehicle frame. Tack weld as shown in **FIG. 12-1**. Repeat for second Mounting Plate (reposition and tack weld).

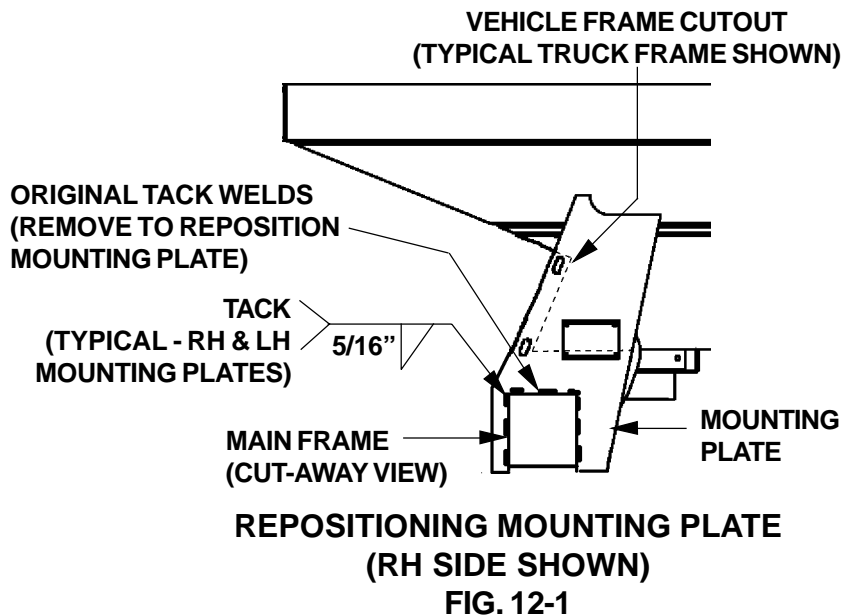

**NOTE:** Weld both Mounting Plates to vehicle frame before welding Mounting Plates to Main Frame.

6. Clamp both Mounting Plates to vehicle frame. Before welding, make sure cutout in vehicle frame does not block 2 slotted holes in Mounting Plate (**FIG. 12-2**). Weld the Mounting Plates to vehicle frame as shown in **FIG. 12-2**. Next, weld both Mounting Plates to Main Frame (**FIG. 12-2**). Remove clamps.

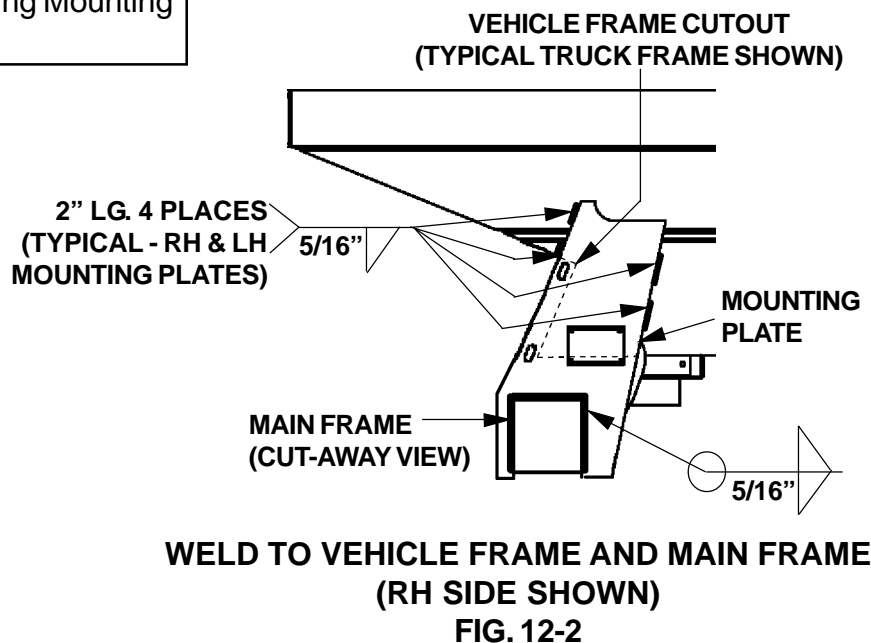

## STEP 3 - WELD LIFTGATE TO VEHICLE - Continued

- At the tip of the Flipover, measure distance Flipover is raised above bed level. Tip of Flipover should be above level line shown in **FIG. 13-1**, and up to 1" maximum (**FIG. 13-1**). If measurement is correct, Liftgate is mounted correctly. If measurement is incorrect, check the measurements used for preparing vehicle in **STEP 1**, and if needed, repeat this entire step (**STEP 3**).

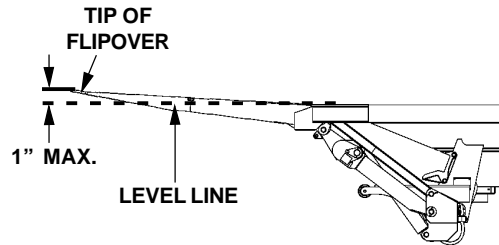

**MEASURING DISTANCE ABOVE BED  
LEVEL AT THE TIP OF FLIPOVER  
FIG. 13-1**

## STEP 4 - RUN POWER CABLE

### ⚠ CAUTION

Never route an energized wire. Make sure the vehicle battery is disconnected. Always route electrical wires clear of moving parts, brake lines, sharp edges and exhaust systems. Avoid making sharp bends in wiring. Attach securely. If drilling is necessary, first check behind the drilling surface so you do not damage any fuel lines, vent lines, brake lines or wires.

Clip Fused Power Cable to vehicle chassis, with fuse nearest the vehicle battery, as shown in FIG. 14-1. Keep enough cable near the battery to reach the positive terminal without putting tension on cable (after connection). Run bare wire end of cable to Liftgate.

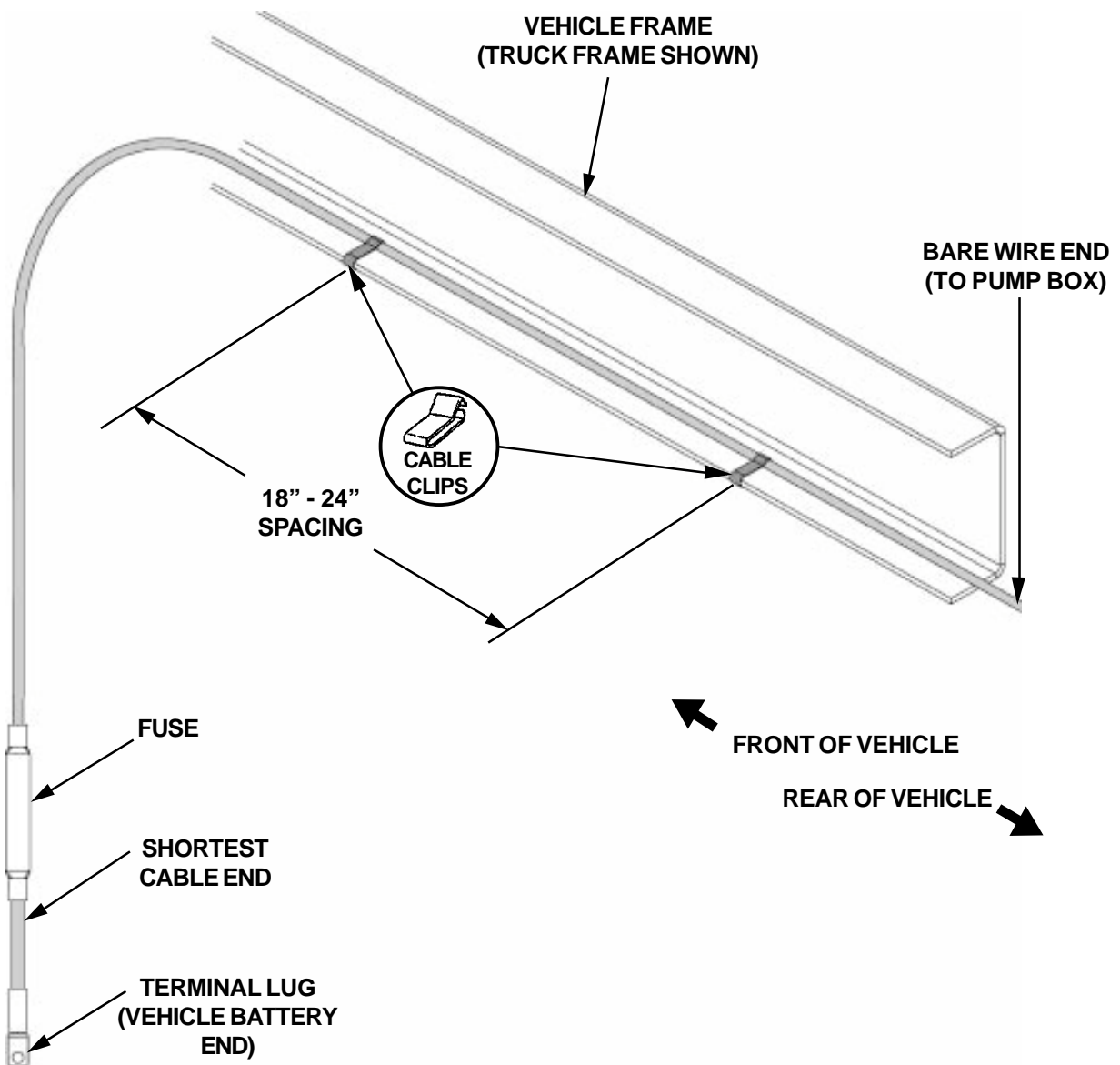
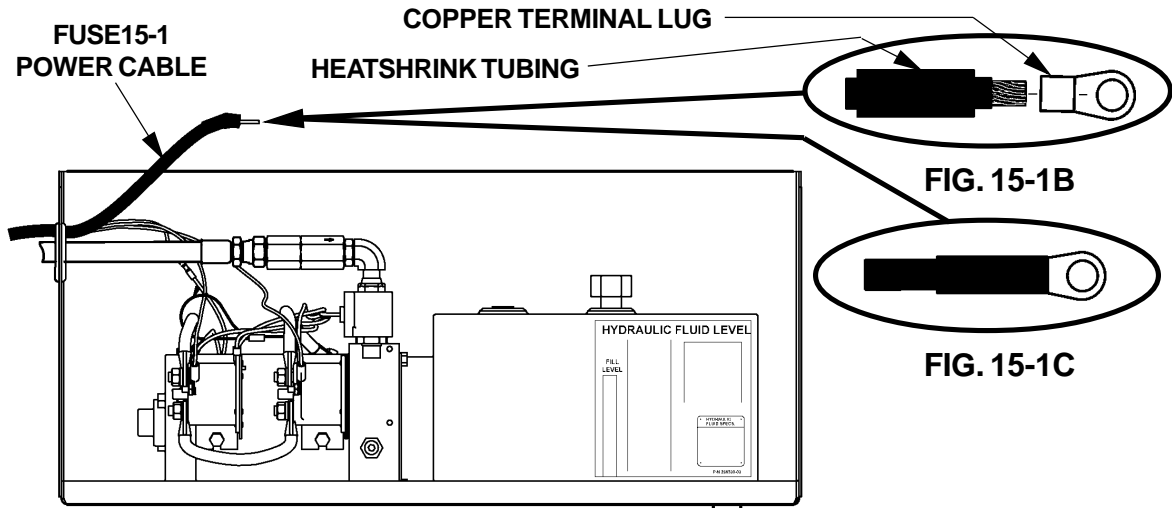

FIG. 14-1

## STEP 5 - CONNECT POWER CABLE

1. On the bare wire end of Fused Power Cable, keep enough length to attach copper terminal lug and reach Motor Solenoid without putting tension on cable (after connection) (**FIG. 15-1A**). Measure (if needed) and then cut excess cable from bare wire end of cable. Put heatshrink tubing (Parts Box) (**FIG. 15-1B**) on the end of the cable (leave room for terminal lug). Crimp copper terminal lug (from Parts Box) on the Fused Power Cable and shrink the Heatshrink Tubing (**FIG. 15-1C**).



**TYPICAL FUSED POWER CABLE ROUTING  
(POWER DOWN PUMP BOX SHOWN)  
FIG. 15-1A**

2. Remove hex nut and lock washer from battery power post on the **RAISE** Motor Solenoid. Connect the Fused Power Cable to the **RAISE** Motor Solenoid as shown in **FIG. 15-2**. Re-install and tighten lock washer and hex nut.

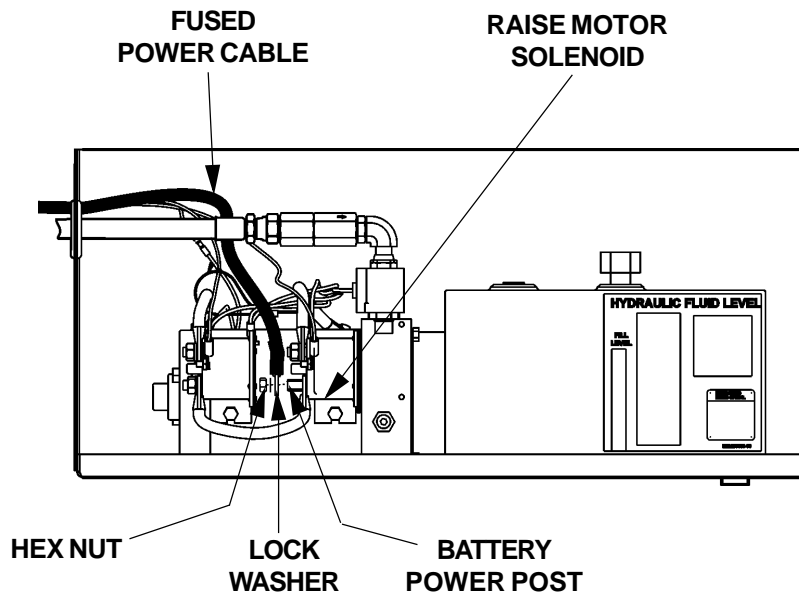

**TYPICAL FUSED POWER CABLE ELECTRICAL CONNECTION  
(POWER DOWN PUMP BOX SHOWN)  
FIG. 15-2**

## STEP 6 - INSTALL CONTROL SWITCH

1. Drill one 3/4" hole and two #21-size holes in the vertical post on curb side of vehicle body as shown in FIG. 16-1A. Use template shown in FIG. 16-1B.

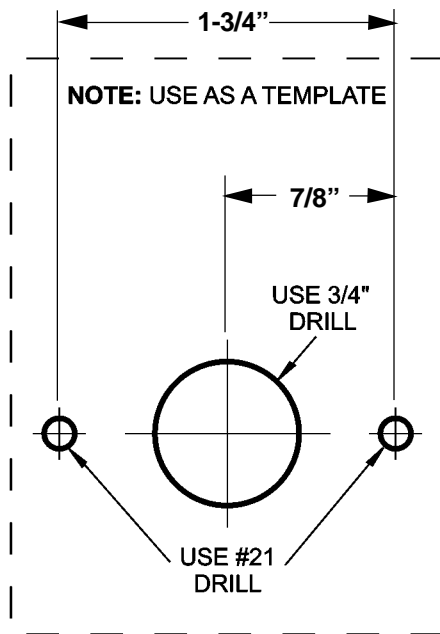

**HOLE TEMPLATE**  
**FIG. 16-1B**

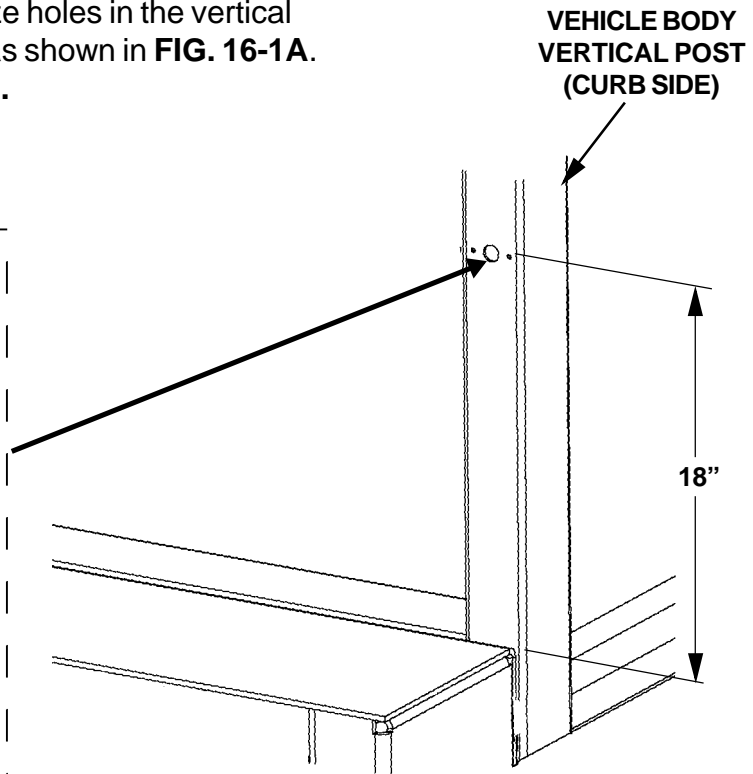
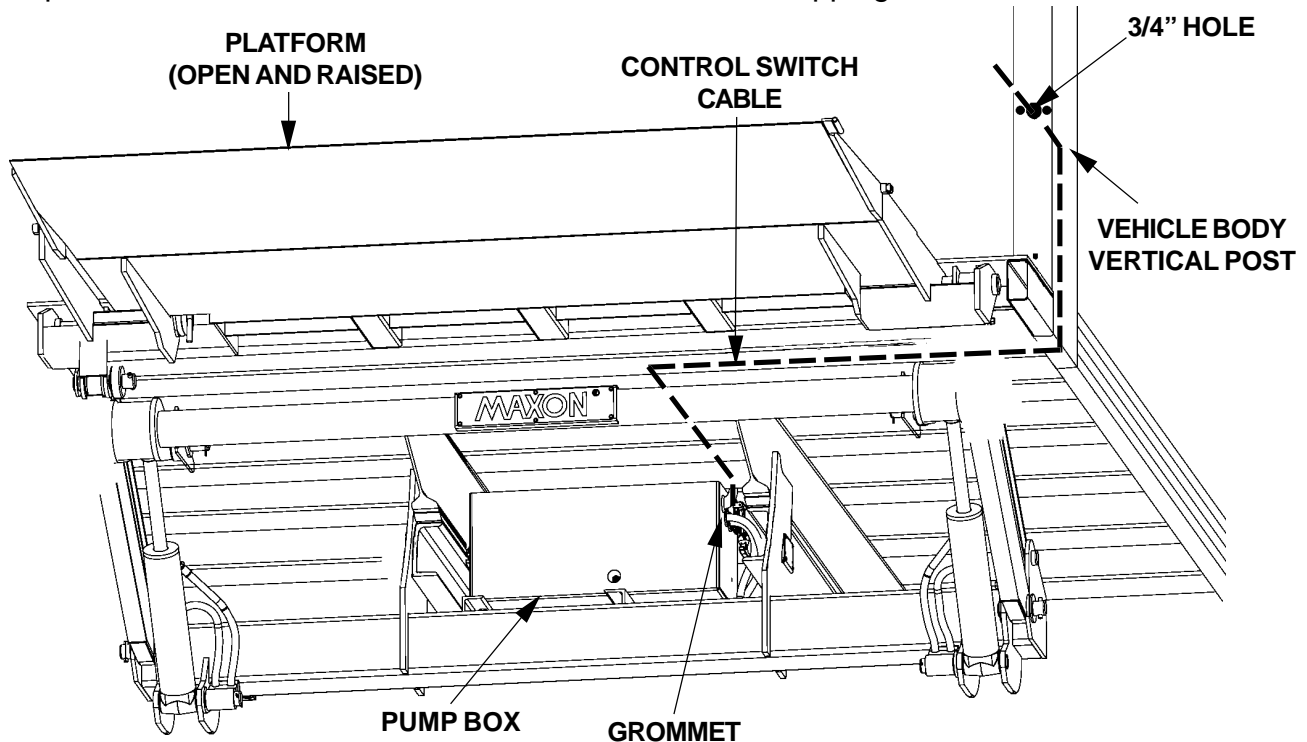

**FIG. 16-1A**



## STEP 6 - INSTALL CONTROL SWITCH - Continued

2. Get the Control Switch wiring harness in the Pump Box. Uncoil the wiring harness and run it through grommet on Pump Box Wall. Run wiring harness under Vehicle Body (see dashed line in FIG. 17-1) and up through inside of Vertical Post. Then pull Control Switch wiring harness out the 3/4" hole drilled in Vertical Post (FIG. 17-2). Use 2 loom clamps and 2 self-tapping screws (Parts Box) to secure the Control Switch wiring harness to vehicle frame. Connect the Control Switch wiring to the wiring harness as shown in (FIG. 17-2). Push extended wiring back into the 3/4" hole in the Vertical Post until Control Switch touches the post. Attach Control Switch to Vertical Post with 2 self-tapping screws.



ROUTING CONTROL SWITCH WIRING  
FIG. 17-1

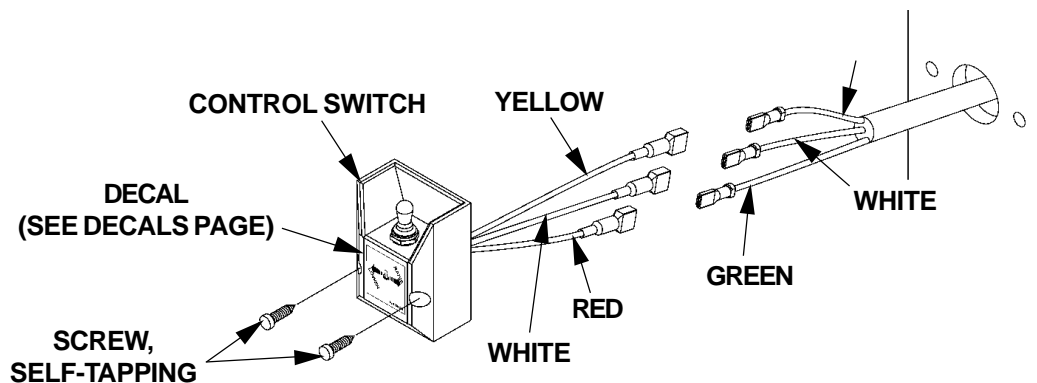

CONTROL SWITCH WIRING CONNECTIONS  
FIG. 17-2

## STEP 7 - CONNECT POWER CABLE TO BATTERY

Remove nut from positive (+) battery terminal connector. Connect Power Cable to the positive (+) battery terminal connector (**FIG. 18-1**). Re-install and tighten nut.

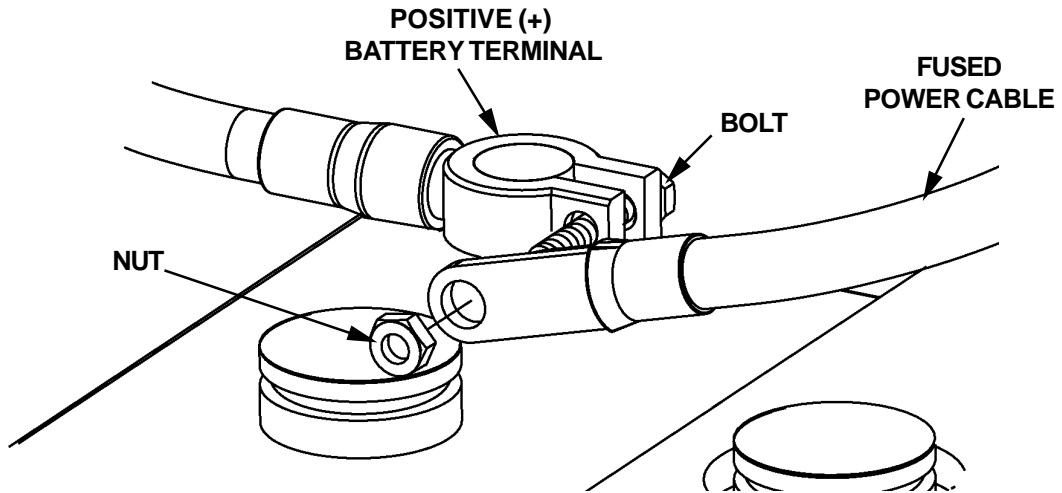

**FIG. 18-1**

## STEP 8 - REMOVE LOCKING ANGLES & WELDS

1. Push Control Switch to **RAISE** position to pressurize Hydraulic System. Listen for Hydraulic Fluid flowing through the system. Check for fluid leaks. (If there are leaks, release the Control Switch and correct the leaks before fully pressurizing system.) When the sound of flowing fluid stops, release Control Switch. Hydraulic System is ready.

**NOTE:** To operate Liftgate, Locking Angles must be removed from the Hydraulic Cylinders and welds must be removed from Lifting Arm Knuckles.

2. Remove Locking Angles from Hydraulic Cylinders (**FIG. 19-1A**).
3. With Platform open (**FIG. 19-1A**), grind off each weld as shown in **FIG. 19-1B & 19-1C**. Make sure block remains on correct side of each Knuckle Joint as shown in **FIG. 19-1D & 19-1E**.

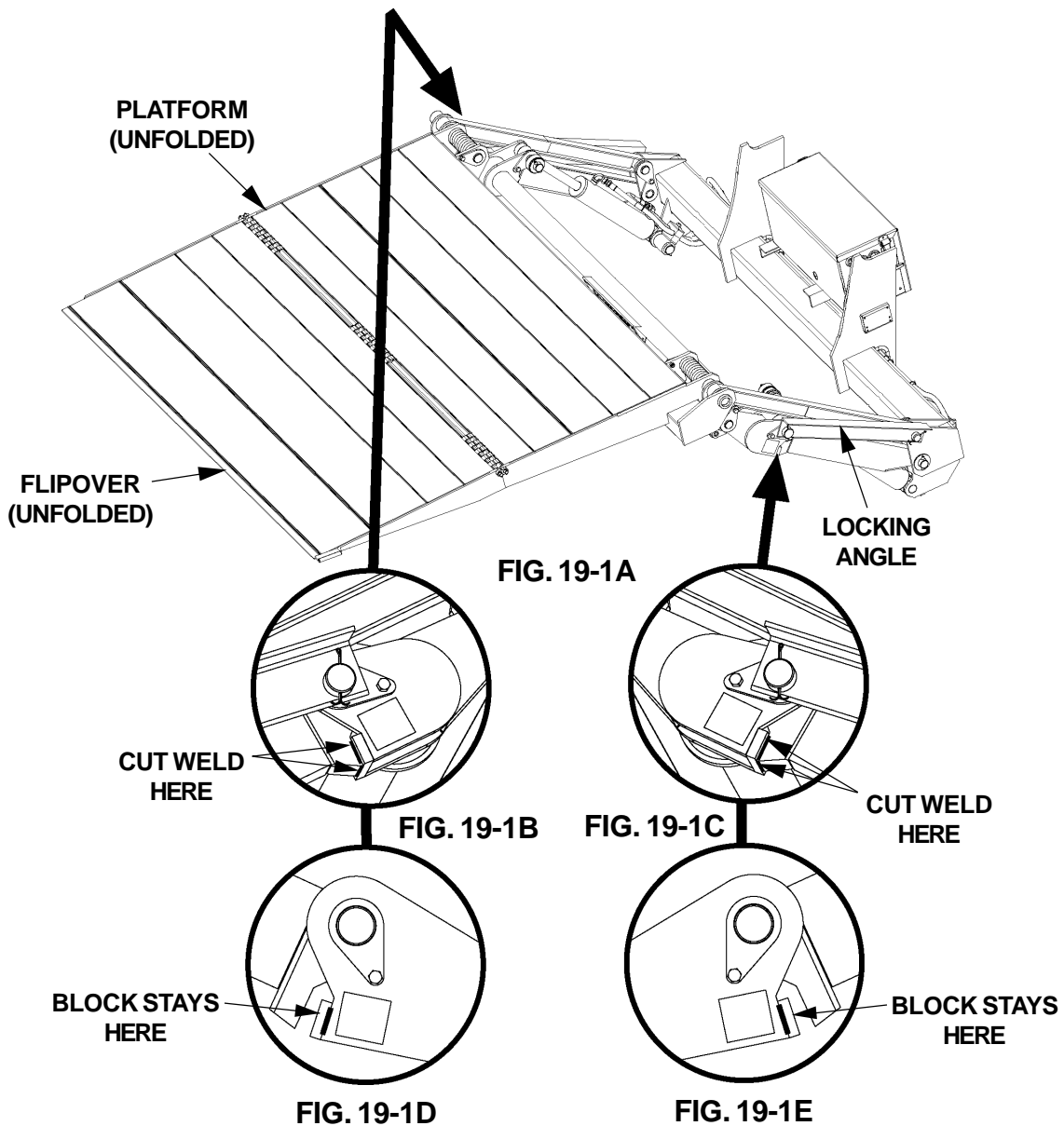

## STEP 9 - WELD PLATFORM OPENER TO LIFTGATE

1. Remove Floor Jack and Hoist supporting Liftgate (**FIG. 20-1**).

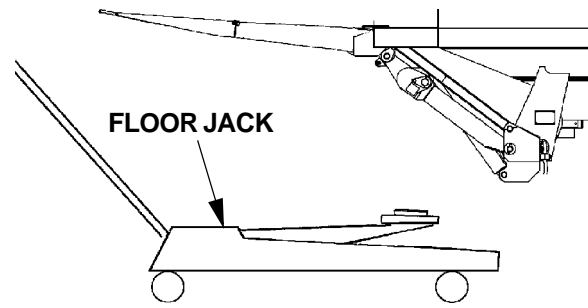

**FIG. 20-1**

2. **LOWER** the Platform to the ground. Remove both support straps and both spacers from Extension Plate (**FIG. 20-2**).

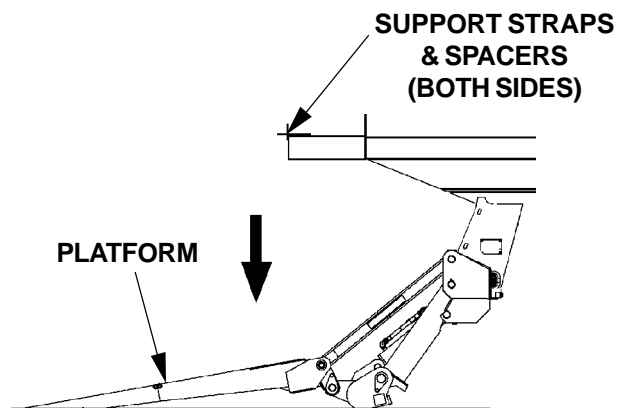

**FIG. 20-2**

3. Fold flipover (**FIG. 20-3**).

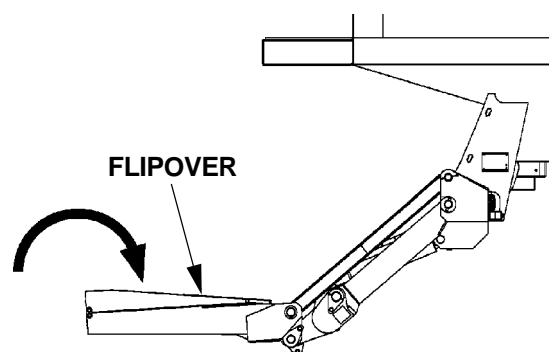

**FOLDING FLIPOVER  
FIG. 20-3**

# STEP 9 - WELD PLATFORM OPENER TO LIFTGATE - Continued

**NOTE:** Platform Opener may only be installed on Right Hand side of Main Frame (see the illustrations on this page).

4. Position the Opener on Main Frame as shown in **FIG. 21-1** and **TABLE 21-1**.

LIFTGATE	"L"
GPT-25/3	16"
GPT-4/5	13"

TABLE 21-1

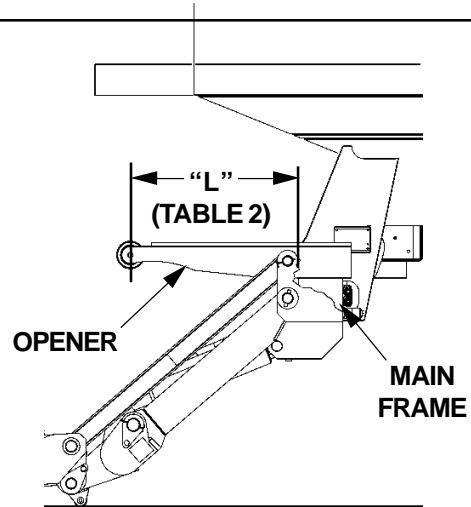

POSITIONING OPENER  
FIG. 21-1

5. Fold the Platform against Opener (**FIG. 21-2A**). Make sure Opener is entered on Protective Plate as shown in **FIG. 21-2B**. Reposition the Opener if necessary. Clamp Opener to Main Frame.

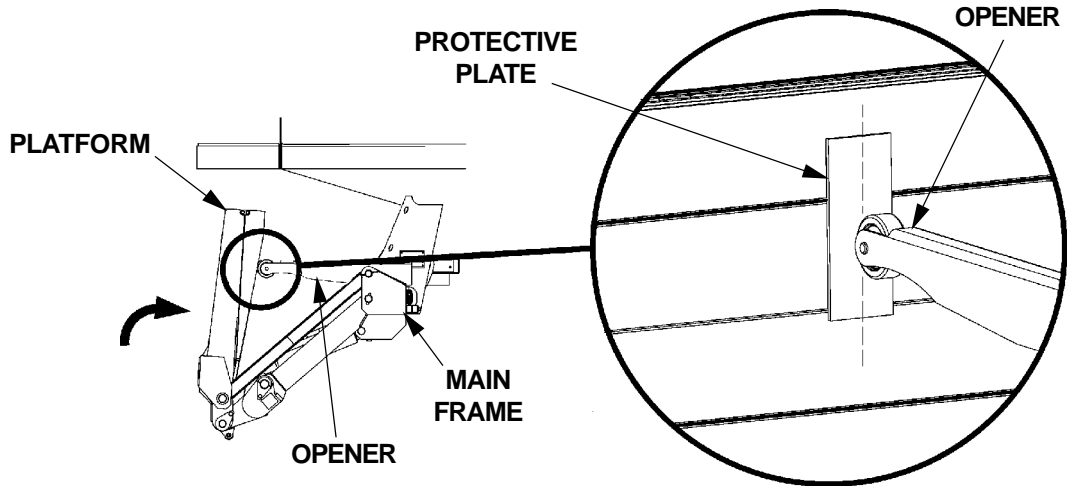

FIG. 21-2A

CENTERING OPENER ON PLATE  
FIG. 21-2B

## STEP 9 - WELD PLATFORM OPENER TO LIFTGATE - Continued

### CAUTION

If there is any interference with the Platform while stowing Liftgate, check for damage on bottom of Platform, Flip Over, and the hinge in between. A damaged Platform or Flip Over may result in personal injury and more damage to Liftgate.

6. Stow and unfold Liftgate several times to verify there is no interference. If there is no interference, weld Opener to Main Frame (FIG. 22-1).

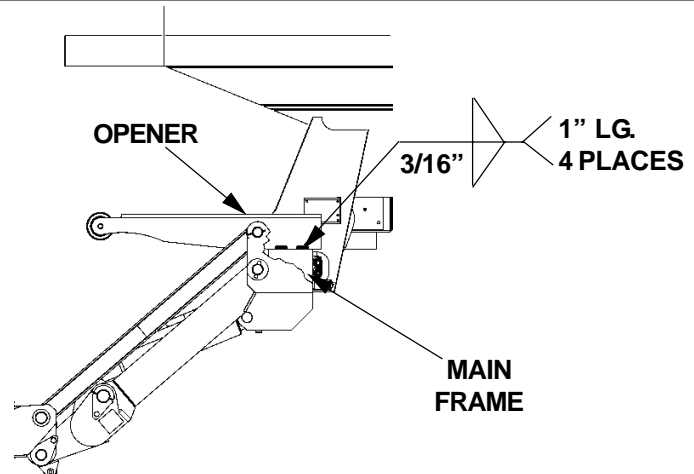

WELDING OPENER TO MAIN FRAME  
FIG. 22-1

7. If the Platform lowered with a “jerk-ing” motion, bleed air from the Hydraulic System by doing the following. Push the Control Switch to the **LOWER** position until you hear air escaping into the Hydraulic Fluid Reservoir. **RAISE** the Platform and then repeat this step until there is no air left in the system and Platform lowers smoothly.

# STEP 10 - FINISH WELDING LIFTGATE TO VEHICLE

## CAUTION

Prevent damaged hydraulic hoses. Before welding next to hydraulic hoses, protect the hoses with a heat-resistant cover such as a welding blanket.

1. Weld each of the two Mounting Plates to Vehicle Frame (FIG. 23-1A).

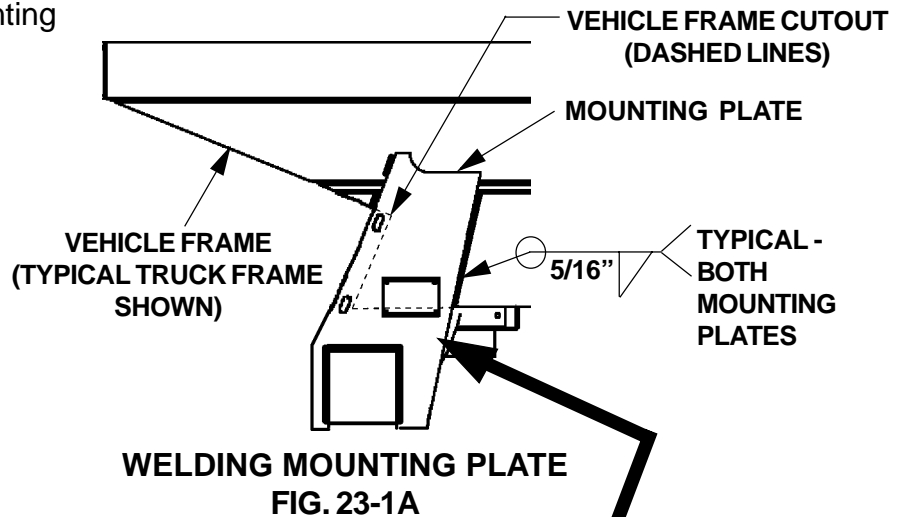

2. After welding is done and Mounting Plates are cool, remove the 4 Fiberglass Sleeves shown in FIG. 23-1B. Then reinstall the Split Looms removed in STEP 3 (FIG. 23-1B).

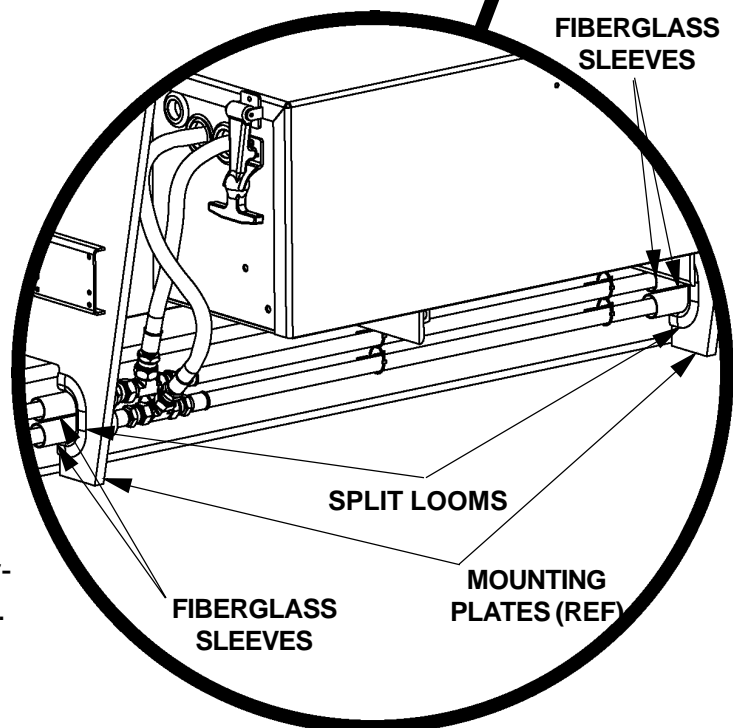

# STEP 11 - INSTALL & ADJUST SADDLES

## ! CAUTION

Make sure Mounting Plates are cooled before installing Saddles. Hot surface could result in personal injury and damaged Saddles.

1. Stow the Platform as shown in **FIG. 24-1A**. Use floor jack positioned at center of Platform (near hinge) to raise Platform 1/8" above Roller (**FIG. 24-1B**). Install Saddle, Bolts and Lock Nuts on RH side Mounting Plate (**FIG. 24-1A**). Repeat for Saddle on LH side. Butt each Saddle against Platform, and tighten lock nuts.

2. Install Saddle, Bolts and Lock Nuts on RH side Mounting Plate (**FIG. 24-1A**). Repeat for Saddle on LH side. Butt each Saddle against Platform, and tighten lock nuts.

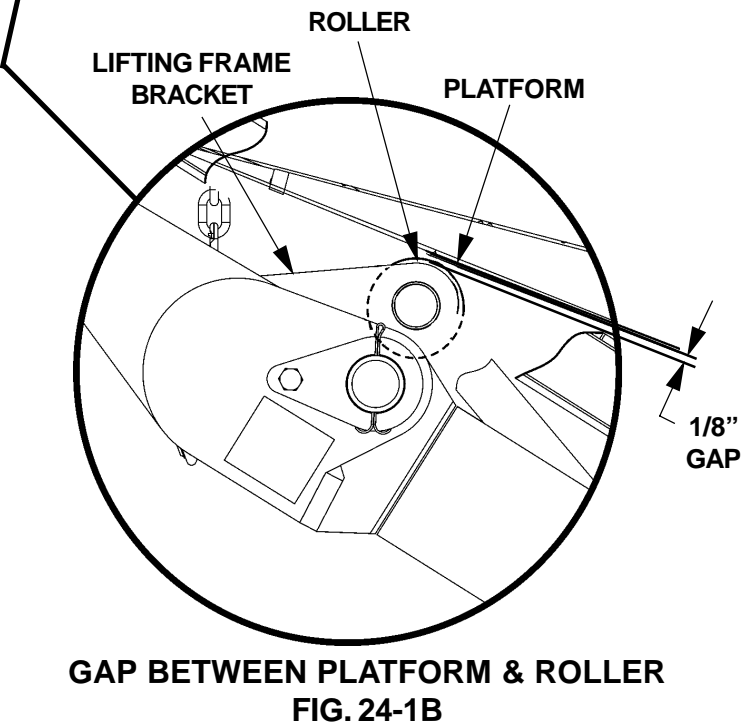
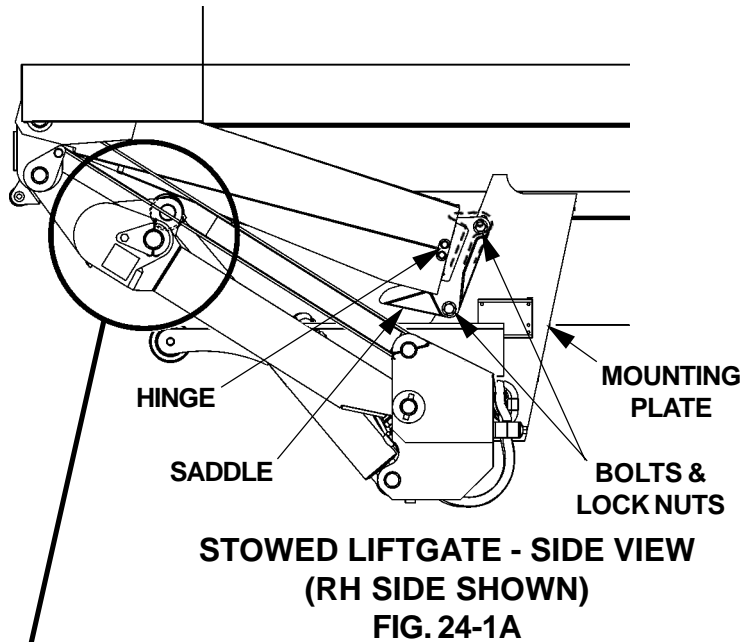



# STEP 12 - CHECK HYDRAULIC FLUID

**NOTE:** Use correct grade of hydraulic fluid for your location.

- +70 to +140 Degrees F - Grade ISO 32**
- +40 to +105 Degrees F - Grade ISO 15**
- Below + 70 Degrees F - Grade ISO 10 or MIL-H-5606**

See TABLES 25-1, 25-2, & 25-3 for recommended brands.

1. Remove the Filler Cap (FIG. 25-1).

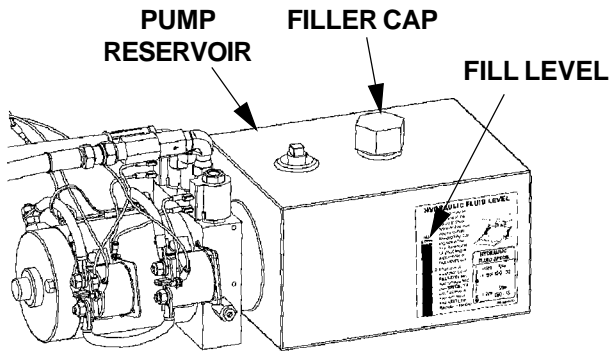

**CHECKING HYDRAULIC FLUID LEVEL**  
**FIG. 25-1**

2. Check the Hydraulic Fluid level in the Pump Reservoir (FIG. 25-1). If fluid is below **FILL LEVEL** shown on Pump Reservoir (FIG. 25-1), add fluid to the **FILL LEVEL**.

3. Reinstall the Filler Cap (FIG. 25-1).

ISO 32 HYDRAULIC OIL	
RECOMMENDED BRANDS	PART NUMBER
AMSOIL	AWH-05
CHEVRON	HIPERSYN 32
KENDALL	GOLDEN MV
SHELL	TELLUS T-32
EXXON	UNIVIS N-32
MOBIL	DTE-13M, DTE-24, HYDRAULIC OIL-13

**TABLE 25-1**

ISO 15 HYDRAULIC OIL	
RECOMMENDED BRANDS	PART NUMBER
AMSOIL	AWF-05
CHEVRON	FLUID A, AW-MV-15
KENDALL	GLACIAL BLU
SHELL	TELLUS T-15
EXXON	UNIVIS HVI-13
MOBIL	DTE-11M

**TABLE 25-2**

ISO-10 OR MIL-H-5606 HYDRAULIC FLUID	
RECOMMENDED BRANDS	PART NUMBER
AMSOIL	N/A
CHEVRON	FLUID A, FLUID G
KENDALL	GLACIAL BLU
SHELL	AEROSHELL FLUID-41
EXXON	UNIVIS HVI-13
MOBIL	AERO HFA

**TABLE 25-3**

## STEP 13 - WELD HOOK AND EYE TO LIFTGATE

1. Stow the Liftgate under hydraulic pressure (FIG. 26-1).

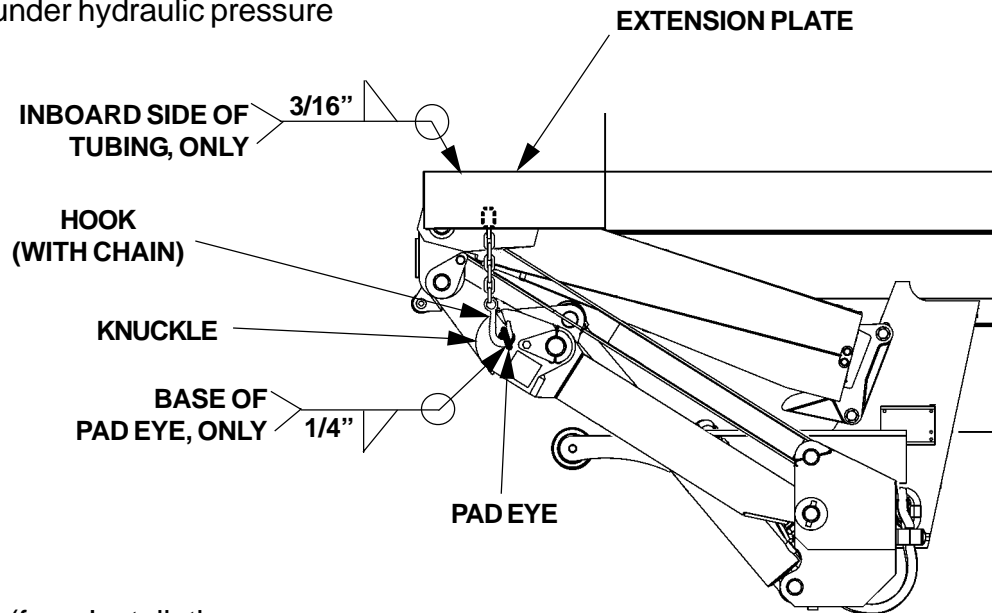

RH SIDE VIEW OF STOWED LIFTGATE  
FIG. 26-1

2. Weld the Pad Eye (from Installation Parts Bag) to Knuckle as shown in FIG. 26-1.

3. Insert the Safety Hook through the Pad Eye (FIG. 26-1). Next position the Safety Hook Chain on the Extension Plate as shown in FIG. 26-1. Leave enough slack in the Chain to hook and unhook the Pad Eye. Then weld the free end of Chain to the inboard side of the tubing on Extension Plate.

# STEP 14 - WELD DOCK BUMPERS TO LIFTGATE

1. Lower the Platform to the ground (**Operation Manual M-97-16**).
2. Clamp a Dock Bumper to Left Hand (LH) side of Extension Plate as shown in **FIG. 27-1A**. Weld the Dock Bumper to Extension plate as shown in **FIG. 27-1B**. Make sure bolt holes in the Dock Bumper are visible from the rear of the vehicle. Repeat step for Dock Bumper on Right Hand (RH) side of Extension Plate.

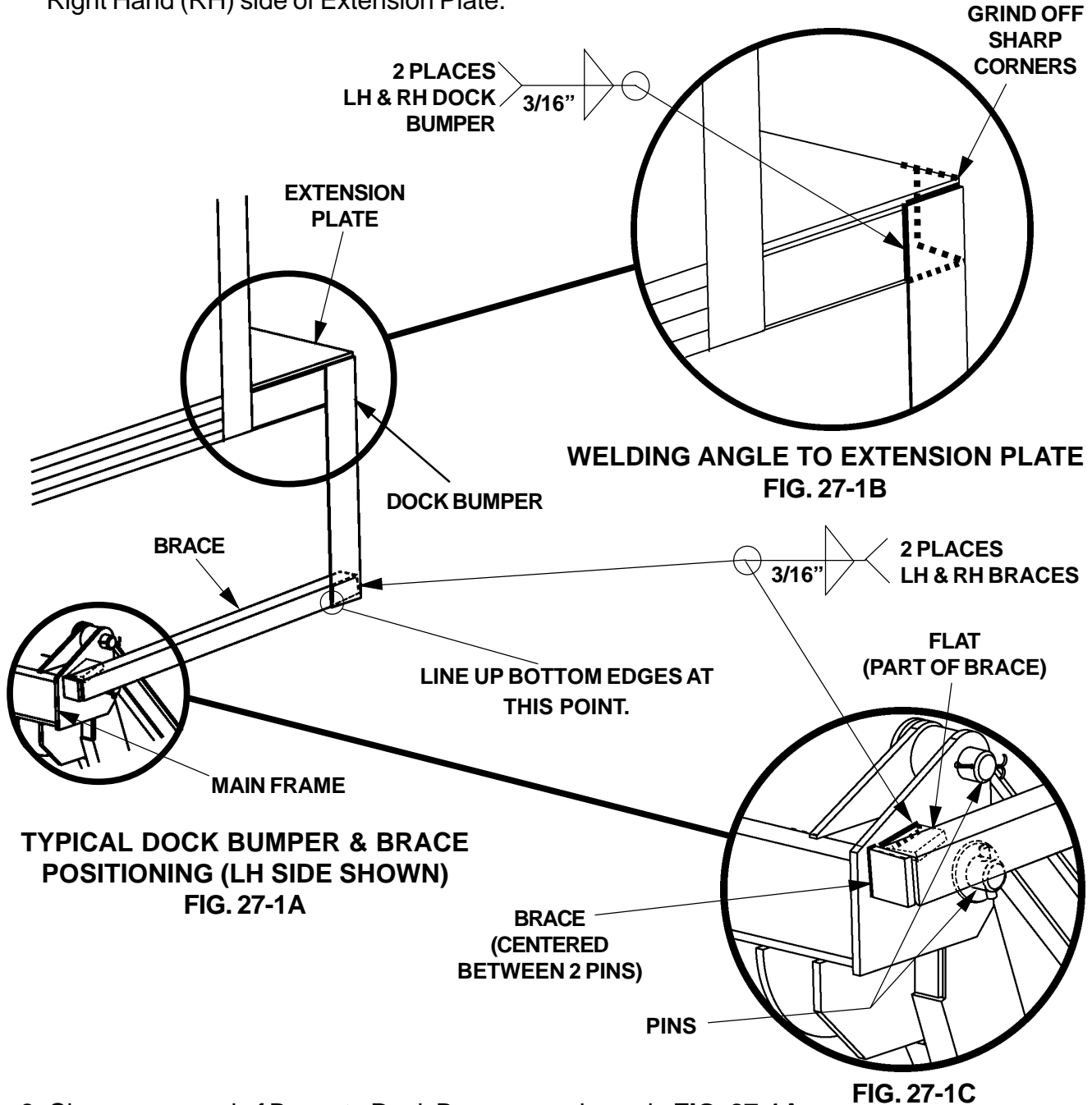

3. Clamp open end of Brace to Dock Bumper as shown in **FIG. 27-1A**. Clamp closed end of Brace to Main Frame (**FIG. 27-1A**). Weld the Brace to Dock Bumper (**FIG. 27-1A**) and Main Frame (**FIG. 27-1C**). Repeat step for Brace and Dock Bumper on RH side of Extension Plate.
4. Raise and lower Platform then stow Liftgate (**Operation Manual M-97-16**). Make sure Dock Bumper does not interfere with Liftgate.

# STEP 15 - BOLT RUBBER BUMPERS TO LIFTGATE

**NOTE:** The Rubber Dock Bumpers Kit P/N 203410 contains 2 Rubber Bumpers and 2 sets of fasteners.

Bolt a Rubber Bumper to each of the 2 Dock Bumpers (FIG. 28-1).

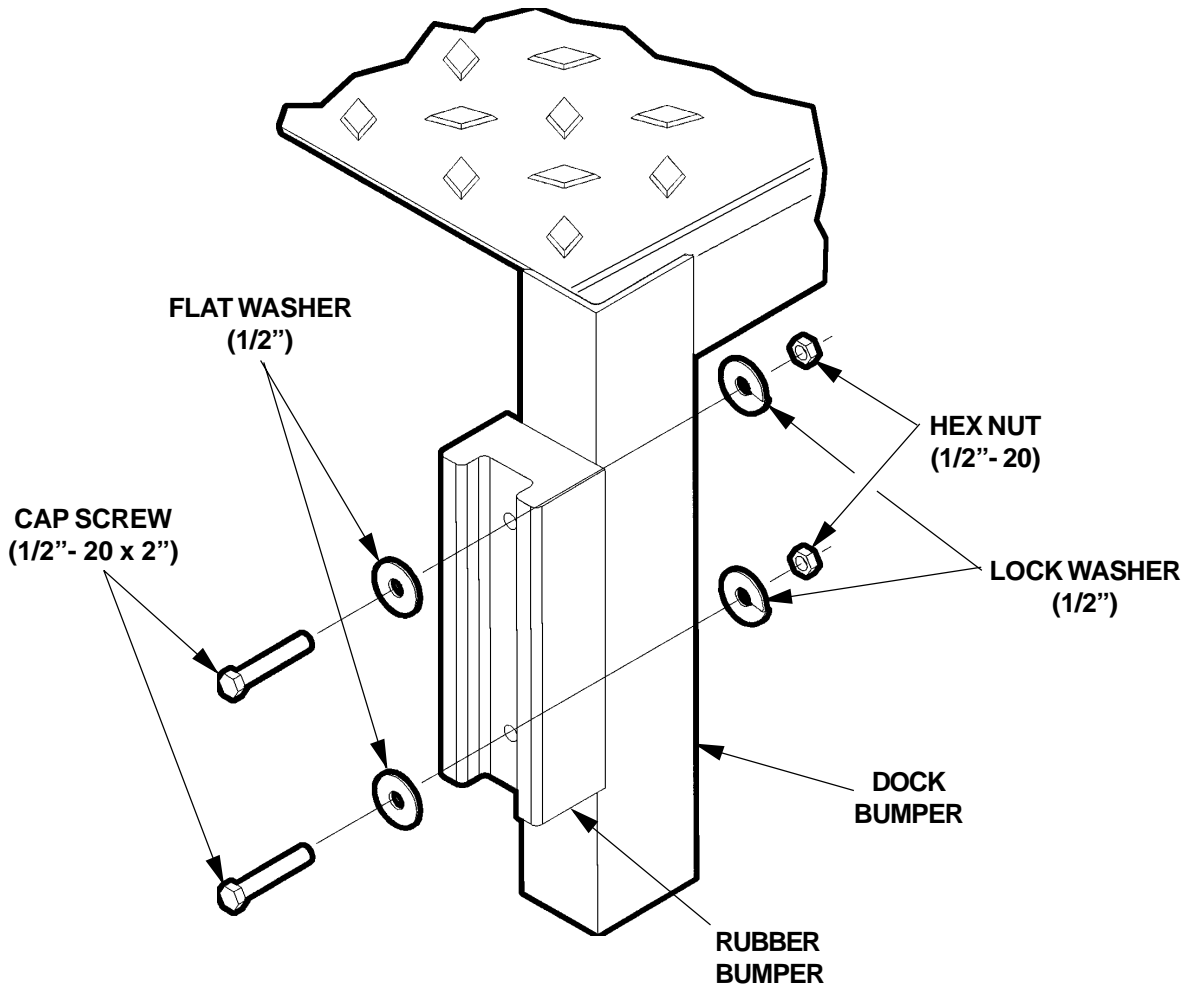

**BOLTING RUBBER BUMPER TO DOCK BUMPER  
(RIGHT HAND SIDE DOCK BUMPER SHOWN)**

**FIG. 28-1**

## STEP 16 - PLACE DECALS

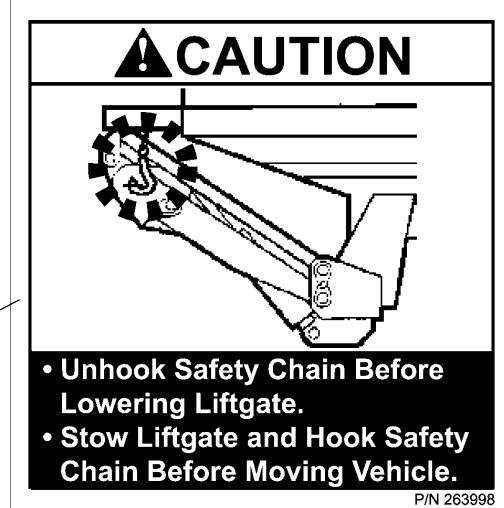
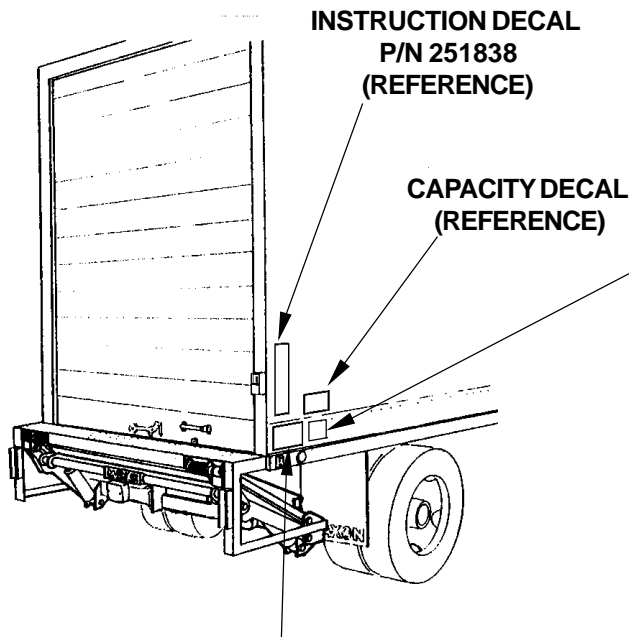

CAUTION DECAL  
P/N 263998

**⚠ WARNING**

**READ THIS INFORMATION CAREFULLY**

- Improper operation of this Lift can result in serious personal injury. Do not operate unless you have been properly instructed and have read, and are familiar with the operating instructions. If you do not have a copy of the instructions, please obtain them from your employer, distributor, or lessor, before you attempt to operate Lift.
- Be certain that the vehicle is properly and securely braked before using the Lift.
- Always inspect this Lift for maintenance or damage before using it. If there are signs of improper maintenance, damage to vital parts, or slippery Platform surface, do not use the Lift until these problems have been corrected.
- Do not overload the Lift. The load limit is based on evenly distributed cargo over the entire Platform surface. If you are using a pallet jack, be sure it can be maneuvered safely. Do not operate a forklift on the Platform or travel with the platform in an open position at any time.
- Load should be placed in a stable position close to the edge of the Platform nearest the truck. The heaviest portion of the load should never be placed beyond the center of the Platform away from the truck.
- Never allow yourself, a helper, or bystander to stand in a position where a falling load could land on either of you. Also do not allow any part of yours or your helper's body to be placed under, within, or around any portion of the moving liftgate, or it's mechanisms, or in a position that would trap them between the platform and the ground or truck when the liftgate is operated.
- If a helper is riding the Platform with you, make sure you are both doing so safely and that you are not in danger of coming in contact with any moving or potentially moving obstacles. **USE GOOD COMMON SENSE.** If load appears to be unsafe, do not lift or lower it.

For a free copy of other manuals that pertain to this model Liftgate, please visit our website at [www.maxonlift.com](http://www.maxonlift.com) or call **Customer Service at (800) 227-4116.**

MAXON LIFT CORP.PART NO. 264081

WARNING DECAL  
P/N 264081

FIG. 29-1

# STEP 16 - PLACE DECALS - Continued

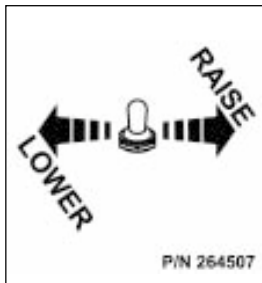

UP/DOWN DECAL  
P/N 264507

WARNING DECAL  
P/N 264081  
(REFERENCE)

CAUTION DECAL  
P/N 263998  
(REFERENCE)

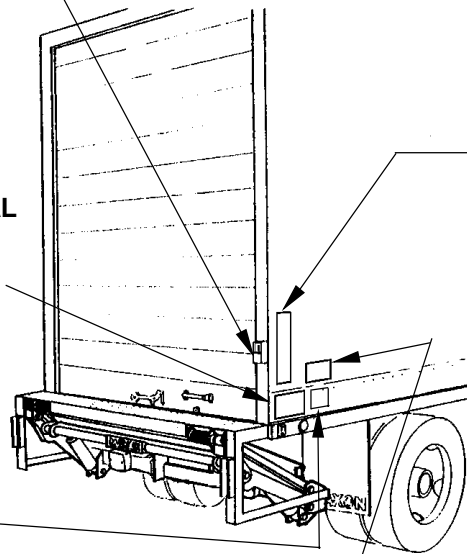

THE MAXIMUM CAPACITY  
OF THIS LIFT IS

POUNDS

WHEN THE LOAD IS  
CENTERED ON PLATFORM

CAPACITY DECAL (SEE TABLE 30-1)

CAPACITY DECALS	
CAPACITY	PART NO.
2500 LBS.	220382
3000 LBS.	220388
4000 LBS.	220389
5000 LBS.	220390

TABLE 30-1

## OPERATING INSTRUCTIONS

GPT & 80 SERIES LIFTGATES

- 1** UNHOOK SAFETY CHAIN.  
(SEE CAUTION DECAL.)
- 2** PUSH CONTROL SWITCH  
(MUST TOUCH THE GROUND)
- 3** UNFOLD PLATFORM.
- 4** UNFOLD FLIPOVER.
- 5** USE SWITCH TO RAISE / LOWER.
- 6** TO TUCK UNIT AWAY REVERSE STEPS 1, 2, 3, & 4.  
DECAL, P/N 251838

INSTRUCTION DECAL  
P/N 251838

FIG. 30-1

# STEP 17 - VEHICLE TAILLIGHT POSITIONING (IF REQUIRED)

**NOTE:** Positions are based on using taillights of 6-3/4" height by 5-3/4" width. Larger taillights may interfere with Liftgate. Taillights and attaching hardware are not provided with the Liftgate. Underride is optional equipment.

Install vehicle taillights (FIG. 31-1) as shown in FIG. 31-2 and FIG. 31-3.

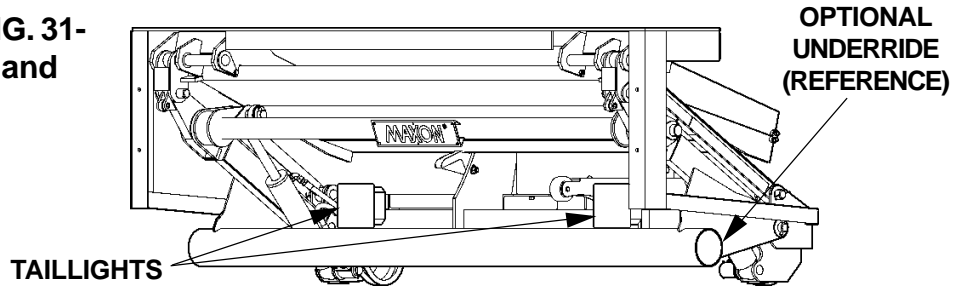

**VEHICLE TAILLIGHTS INSTALLED ON LIFTGATE  
FIG. 31-1**

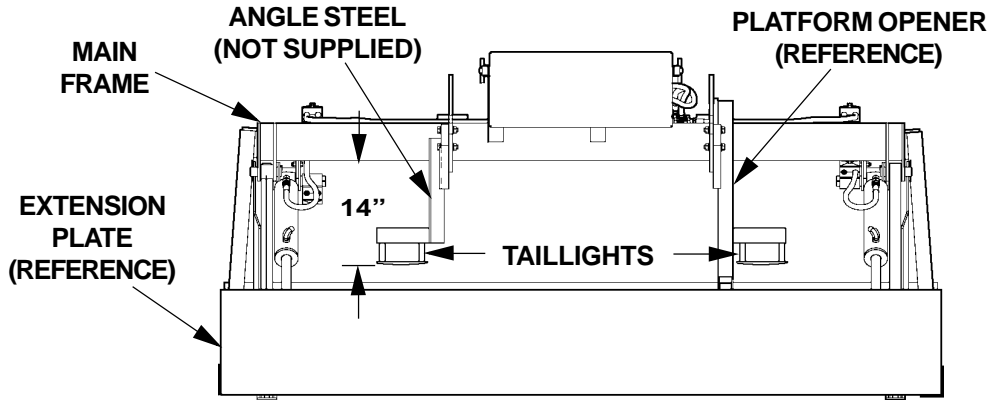

**TAILLIGHTS POSITION (TOP VIEW)  
FIG. 31-2**

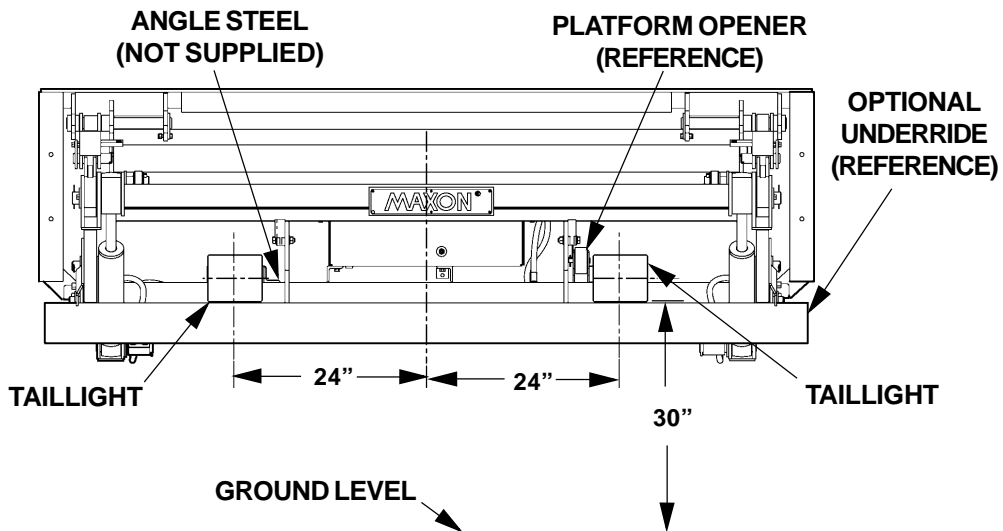

**TAILLIGHTS HORIZONTAL SPACING (FRONT VIEW)  
FIG. 31-3**

# HYDRAULIC SYSTEM SCHEMATIC

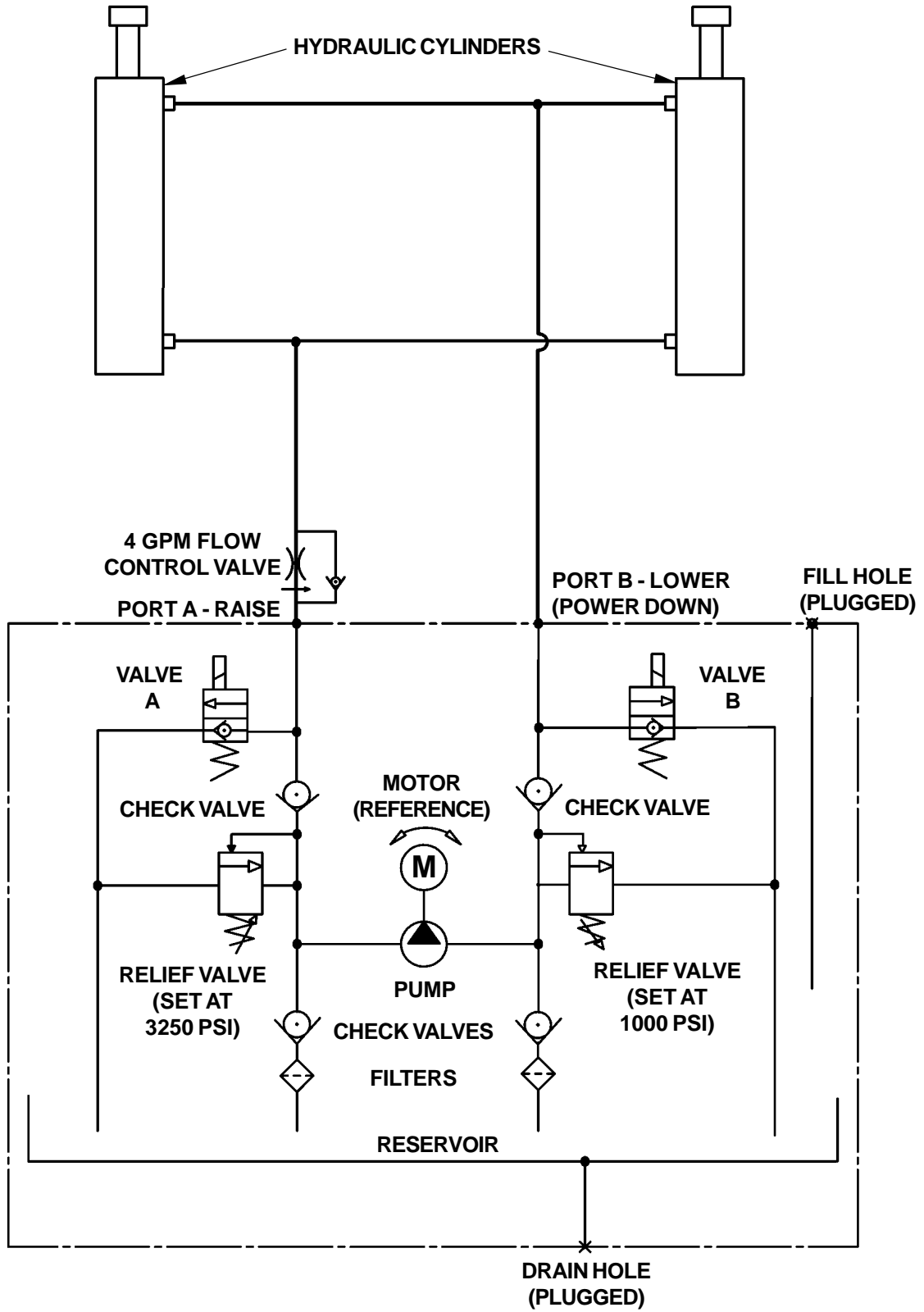

FIG. 32-1



# ELECTRICAL SYSTEM SCHEMATIC

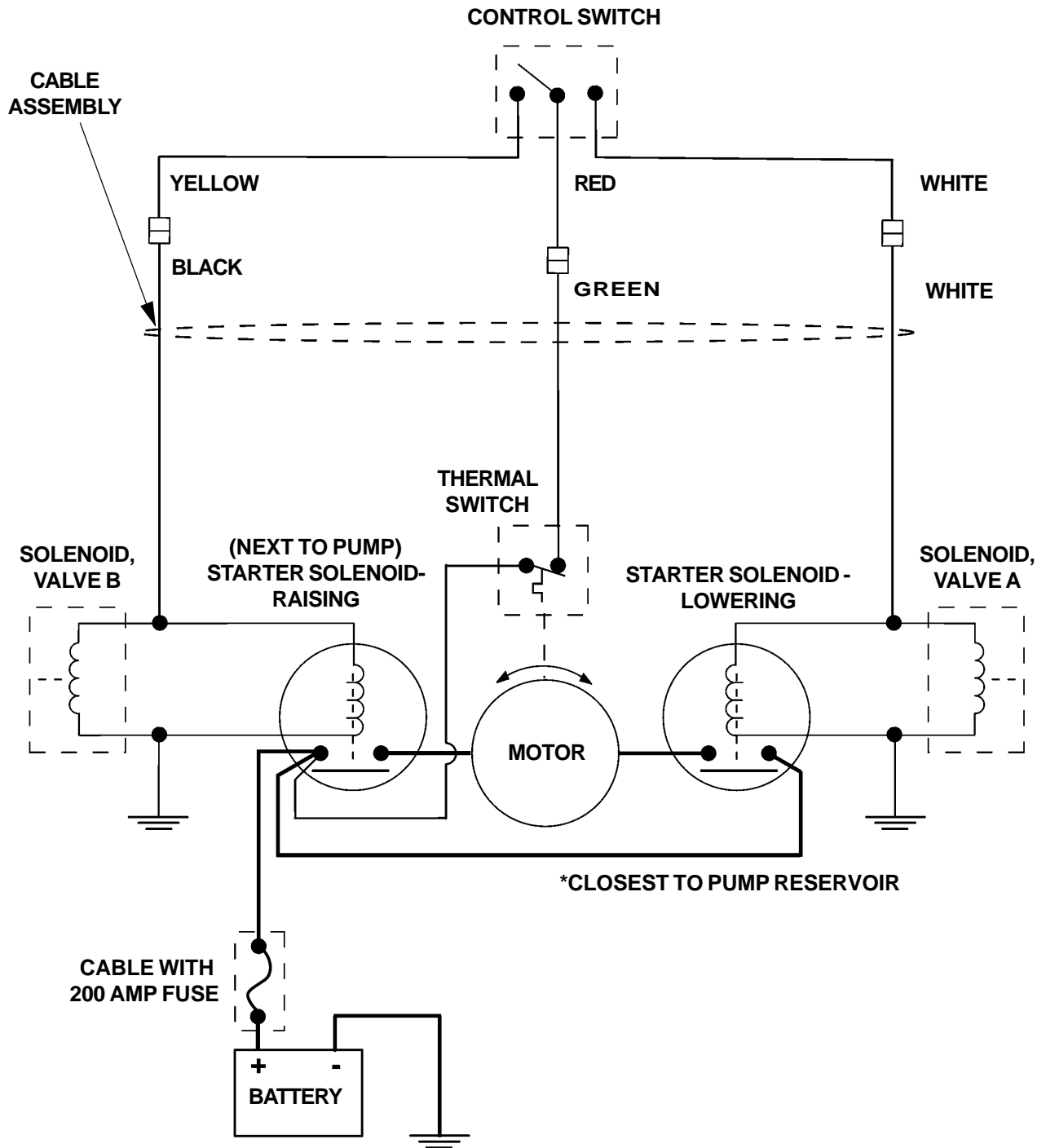

FIG. 33-1

# OPTIONS

## OPTIONAL LIFTGATE COMPONENTS

OPTIONAL COMPONENTS  (OS) - INSTRUCTIONS INCLUDED IN THIS MANUAL	MODELS	
	GPT-25 / GPT-3	GPT-4 / GPT-5
UNDER RIDE KIT*	266042-01	266043-01
LIFTGATE BUMPER KIT*	265860-01	
150 AMP CIRCUIT BREAKER (OS)	251576	
LOW VOLTAGE THERMAL SWITCH (LVTS) KIT (PWR DN)*	280575-01	
CAB CUT OFF SWITCH*	250477	
FRAMELESS TRAILER SUBFRAME MOUNTING KIT	280010	
102" WIDE TRAILER KIT	263552	
BATTERY BOX FOR TRUCK (W/O DELCO BATTERY)	251154-05	
BATTERY BOX FOR TRUCK (WITH BATTERY)	251154-01	
BATTERY BOX FOR TRUCK (W/O BATTERY)	251154-03	
TRAILER CHARGE LINE KIT (SINGLE POLE)	280275-01	
TRAILER CHARGE LINE KIT (DUAL POLE)	280275-02	
TRACTOR CHARGE LINE KIT (SINGLE POLE)	280275-03	
TRACTOR CHARGE LINE KIT (DUAL POLE)	280275-04	
TRACTOR CHARGE LINE KIT (WITH ADAPTER)	280275-05	
TRAILER CHARGE LINE KIT (SINGLE & DUAL POLE)	280275-06	
HAND HELD CONTROL (COILED CORD)*	280570-01	
STREET SIDE CONTROL KIT*	280265-02	
DUAL SWITCH CONTROL KIT*	264845	
2-STEP DOCK BUMPER KIT*	266220-01	

**TABLE 34-1**

# OPTIONS

## RECOMMENDED LIFTGATE POWER CONFIGURATION

1. Liftgate and additional Battery Box are typically installed on trailers as shown in **FIG. 35-1** and on trucks as shown in **FIG. 35-2**. See the following page for battery and cable connections.

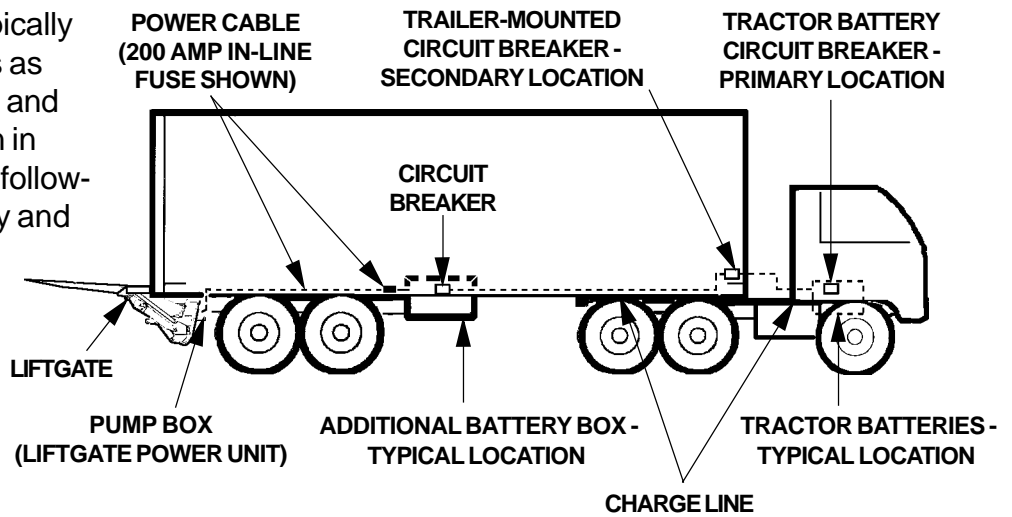

**RECOMMENDED LIFTGATE & BATTERY BOX  
INSTALLATION ON TRAILER  
FIG. 35-1**

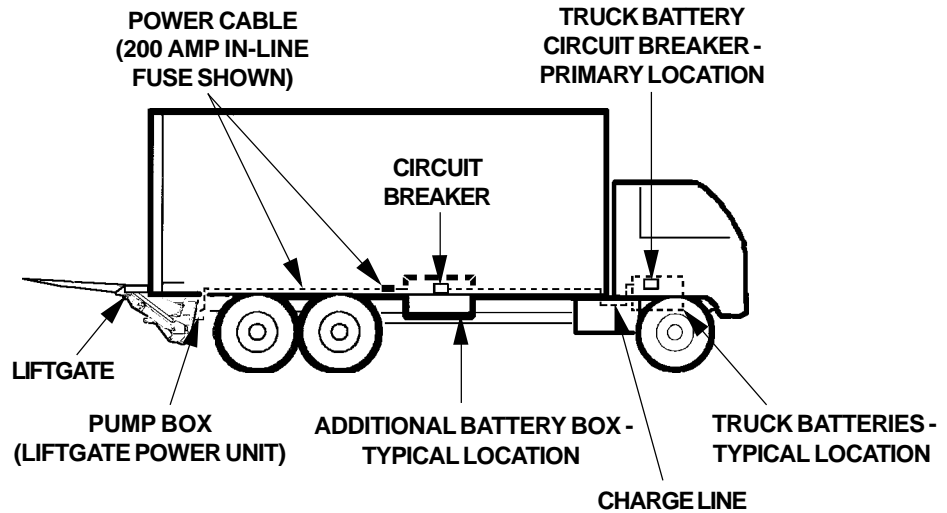

**RECOMMENDED LIFTGATE & BATTERY BOX  
INSTALLATION ON TRAILER  
FIG. 35-2**

# OPTIONS

## RECOMMENDED LIFTGATE POWER CONFIGURATION - Continued

**NOTE:** If more than 10' of cabling is required to connect Battery Box batteries to Liftgate Power Unit, and/or if cable is run through/along vehicle body crossmembers, use 200 Amp Fused Power Cable from Liftgate Parts Box. Always connect fused end of Cable to Battery.

2. Recommended Battery Box setup for 6 volt batteries is shown in FIG. 36-1.

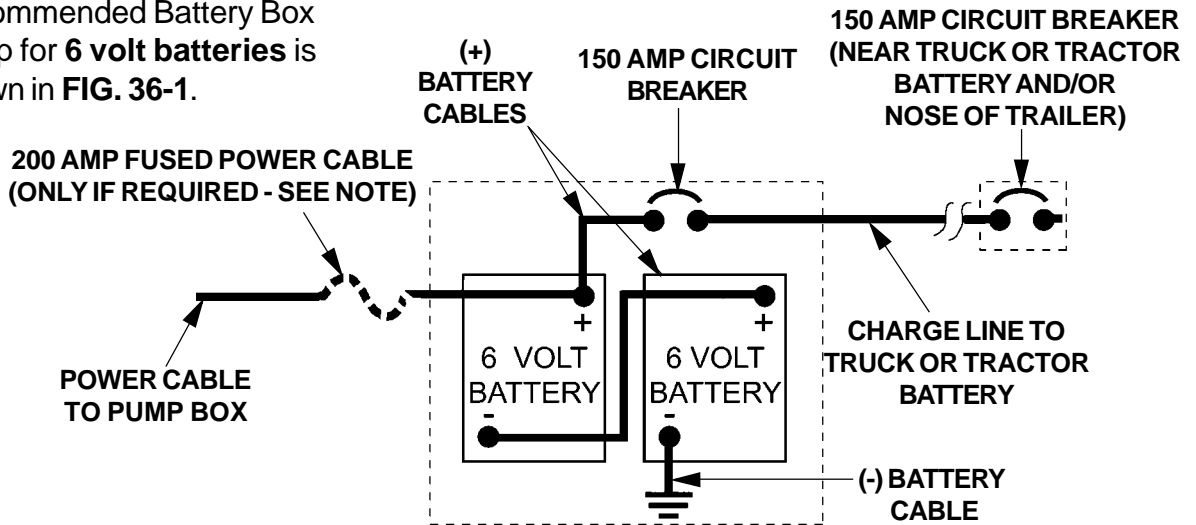

6 VOLT BATTERY CONNECTIONS  
FIG. 36-1

**NOTE:** If more than 10' of cabling is required to connect Battery Box batteries to Liftgate Power Unit, and/or if cable is run through/along vehicle body crossmembers, use 200 Amp Fused Power Cable from Liftgate Parts Box. Always connect fused end of Cable to Battery.

3. Recommended Battery Box setup for 12 volt batteries is shown in FIG. 36-2.

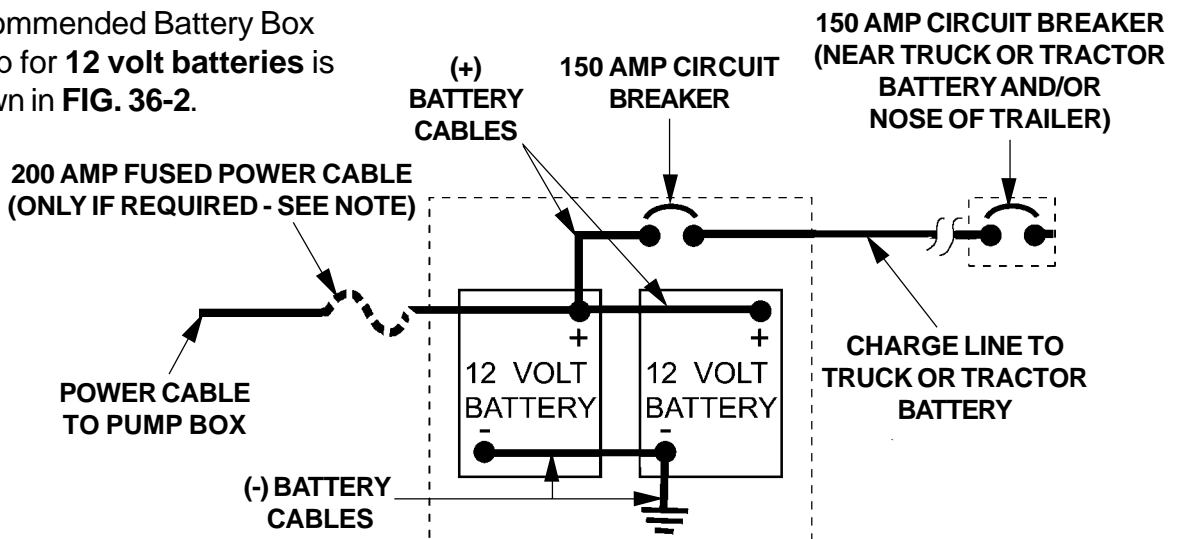

12 VOLT BATTERY CONNECTIONS  
FIG. 36-2

