

MAXON®

OPERATION MANUAL

FOR THE “AHT TAILGATE LOADER” ULTK-1500ST/AL

for Serial Number:
10473-10492

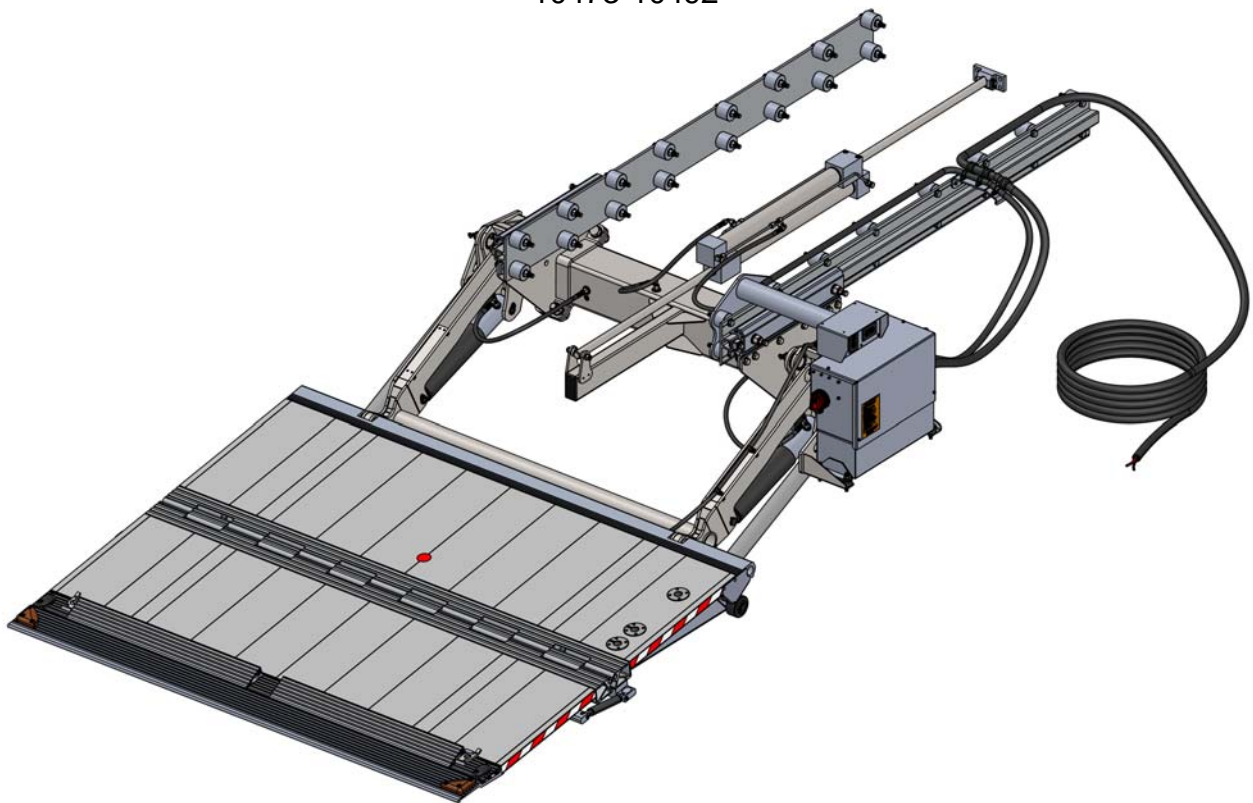

Designed for Maxon by:



Maxon Lift Corp. 11921 Slauson Ave., Santa Fe Springs, CA 90670
800.227.4116 Fax 888.771.7713, www.maxonlift.com

September 2020

HOW TO USE THE “AHT” TAILGATE LOADER

IT IS NOT PERMITTED TO USE THE “AHT” AS:

- A personal lift or elevator Only the operator is permitted to ride up and ride down with the load.
- As an extension of another body. Do not use the „AHT“ to load or unload another vehicle.
- As a car jack. It is very unsafe to lift another vehicle with the “AHT”
- As a snow plow. Heavy damage could be done to your new “AHT”

It is not permitted to overload the platform to a point where the operator does not have enough room to operate the tailgate safely.

USER QUALIFICATIONS TO OPERATE THE “AHT” TAILGATE LOADER

The driver and/or operator should be well trained and should familiar with the operating of the “AHT” before using the tailgate loader.

Carefully read the manual **before starting to operate** the “AHT” tailgate loader.

Only mature adults, age 18 and above, should operate the “AHT” tailgate loader.

The operator should never be under the influence of alcohol or drugs while operating the “AHT”.

The load **must be** stabilized on the platform to avoid damage to equipment or personnel.

The operator must never load or unload more than the maximum capacity of the “AHT” tailgate loader. **Read the data plate for actual capacity of this „AHT“.**

Always perform the daily check before using the „AHT“ tailgate loader.

WARNINGS

1. Incorrect operation of this Liftgate can result in serious personal injury. Comply with **WARNINGS** and Liftgate operating instructions in this manual. Do not allow untrained persons or children to operate the Liftgate. If you need to replace an **Operation Manual**, additional copies are available from:

MAXON Lift Corp.
11921 Slauson Ave
Santa Fe Springs, CA 90670
(800) 227-4116

NOTE: For latest version manuals (and replacements), download manuals from Maxon's website at **www.maxonlift.com**.

2. Do not exceed rated load capacity of the Liftgates, which is **2500 LB for the GPT-25 & GPTWR-25, 3000 LB for the GPT-3 & GPTWR-3, 4000 LB for the GPT-4 & GPTWR-4, & 5000 LB for the GPT-5 & GPTWR-5.**
3. Do not allow any part of your body to be placed under, within, or around any portion of the moving Liftgate or its mechanisms, or in a position that would trap them between the platform and the floor of truck body (or between platform and the ground) when Liftgate is operating.
4. Consider the safety and location of bystanders and location of nearby objects when operating the Liftgate. Stand to one side of platform while operating the Liftgate. Be certain that the area the Liftgate will move through during operation is clear of all obstacles.
5. Comply with all attached instruction decals and warning decals.
6. Keep decals clean and legible. If decals are illegible or missing, have them replaced. **Get free replacement decals from Maxon.**
7. **Never drive a forklift on the Liftgate platform.**
8. Do not move vehicle unless Liftgate is correctly stowed.
9. **Correctly stow platform when not in use. Extended platforms could create a hazard for people and vehicles passing by.**
10. A correctly installed Liftgate will operate smoothly and reasonably quiet. The only noticeable noise, during Liftgate operation, is from the power unit while the platform is raised. Listen for scraping, grating and binding noises and have the problem corrected before continuing to operate the Liftgate.
11. Above all, **USE GOOD COMMON SENSE** when operating the Liftgate.
12. Never use a cell phone while operating the Liftgate.

LIFTGATE TERMINOLOGY

The “AHT” tailgate loader has the following components:

- | | | | |
|-----|------------------|---------|------------------------|
| 1) | Cross beam | (ST) | ST... made of steel |
| 2) | Lift arm | (ST) | AL... made of aluminum |
| 3) | Platform | (AL) | |
| 4) | Sliding brackets | (ST/AL) | |
| 5) | Lift cylinders | (AL) | |
| 6) | Lever arms | (AL) | |
| 7) | Tilting brackets | (ST) | |
| 8) | Rails | (AL) | |
| 9) | Feed cylinder | (ST/AL) | |
| 10) | Hose guide | (AL) | |
| 11) | Power pack | (AL) | |
| 12) | Control box | (AL) | |

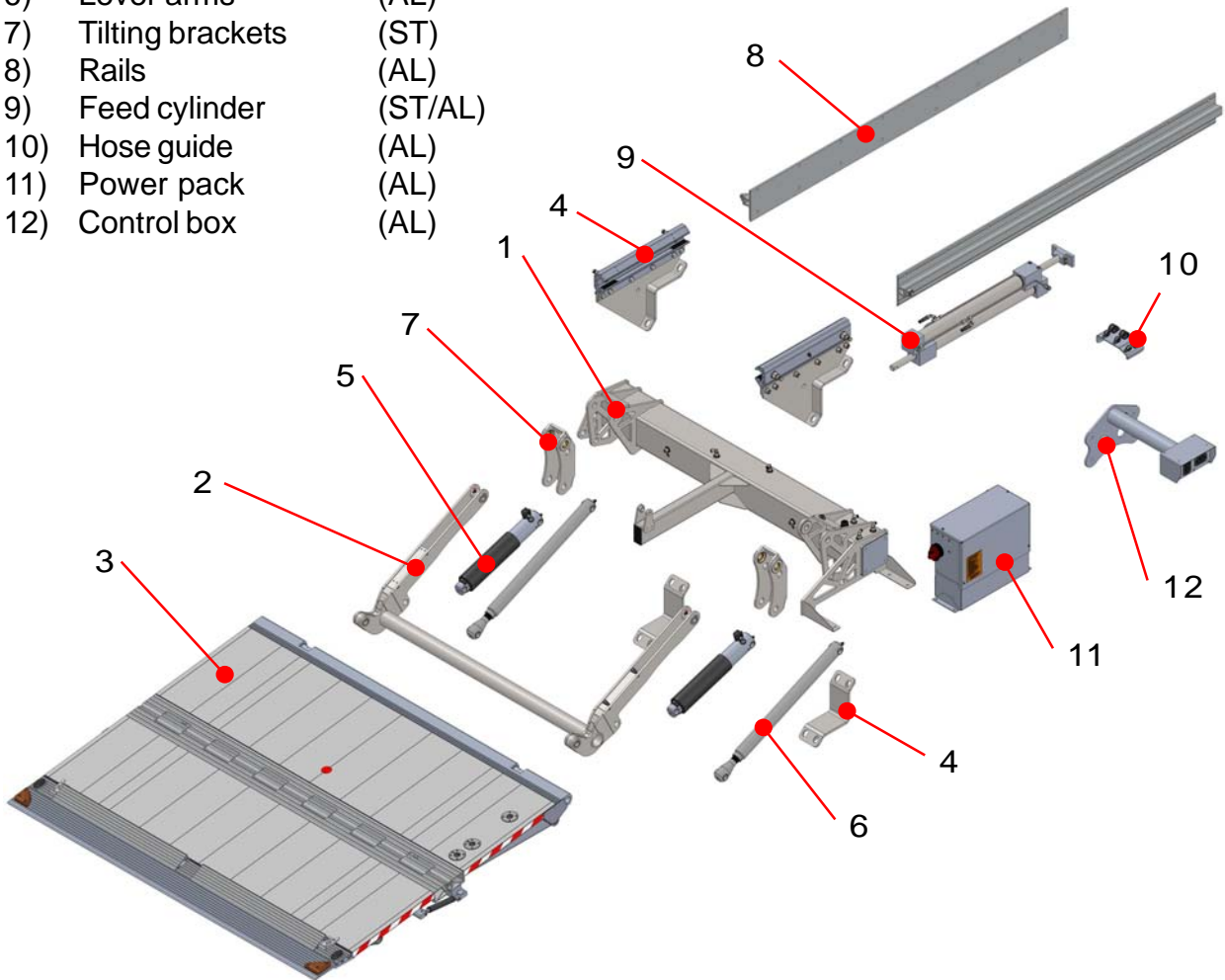

The cross beam (1) is mounted to the sliding rails (8) with the sliding brackets (4).

For lifting the load, we use two single-acting aluminum lift cylinders (5). All two cylinders have ceramic-coated, salt and chemical resistant, aluminum piston rods for ultra long life span.

Each of the two lift cylinders is equipped with a electrical hose burst valve for safety. In case of hydraulic hose failure, the platform (3) cannot fall to the ground. The failed hose can be replaced and the “AHT” can go back to work.

For extending and retracting the „AHT“ we use a double acting feed cylinder (9).

The platform tilting is manually adjustable with the lever arms (6).

If platform contacts the ground by lowering, the tilting brackets (7) tilts the platform tip to the ground.

LIFTGATE TERMINOLOGY ALUMINUM PLATFORM

The platform is made from aluminum high strength profiles and is designed to maintain the load and keep it stabilized for your safety. The platform is folded for a smaller transporting length.

Safety options available for the all-aluminum "AHT" platform:

- 1) Spring loaded roll stops
- 2) Flashing lights for safety, when the "AHT" is being operated.
- 3) Safety flags so the platform can be seen from the rear while in operation.
- 4) Safety warning strips for the edge of platform.
- 5) Three button foot control (Required in EU countries)
- 6) Bumpers
- 7) Gas pressure springs
- 8) Handle strap

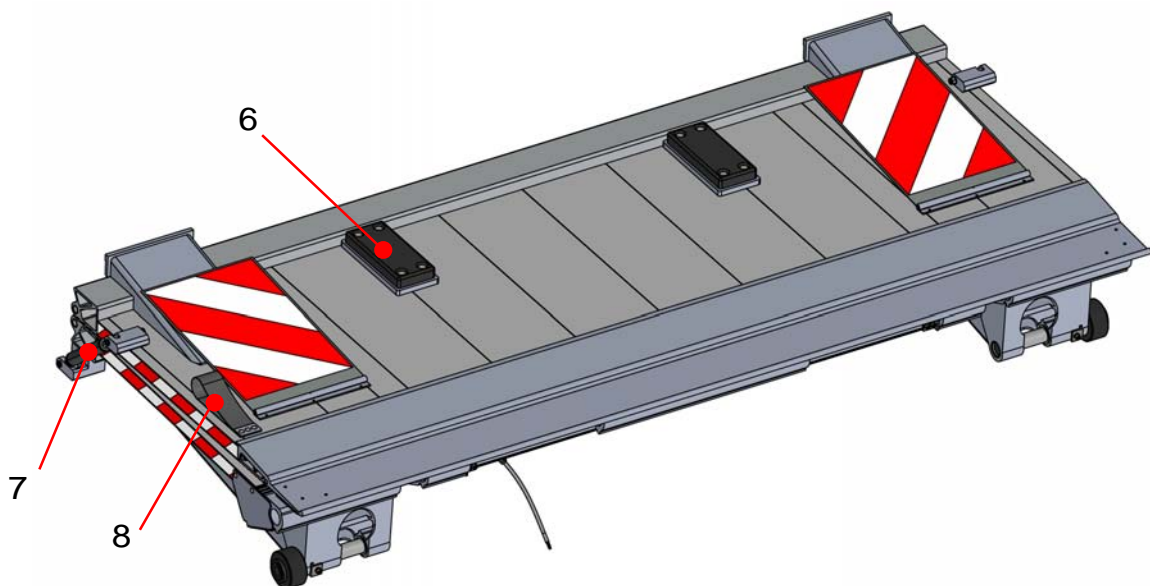
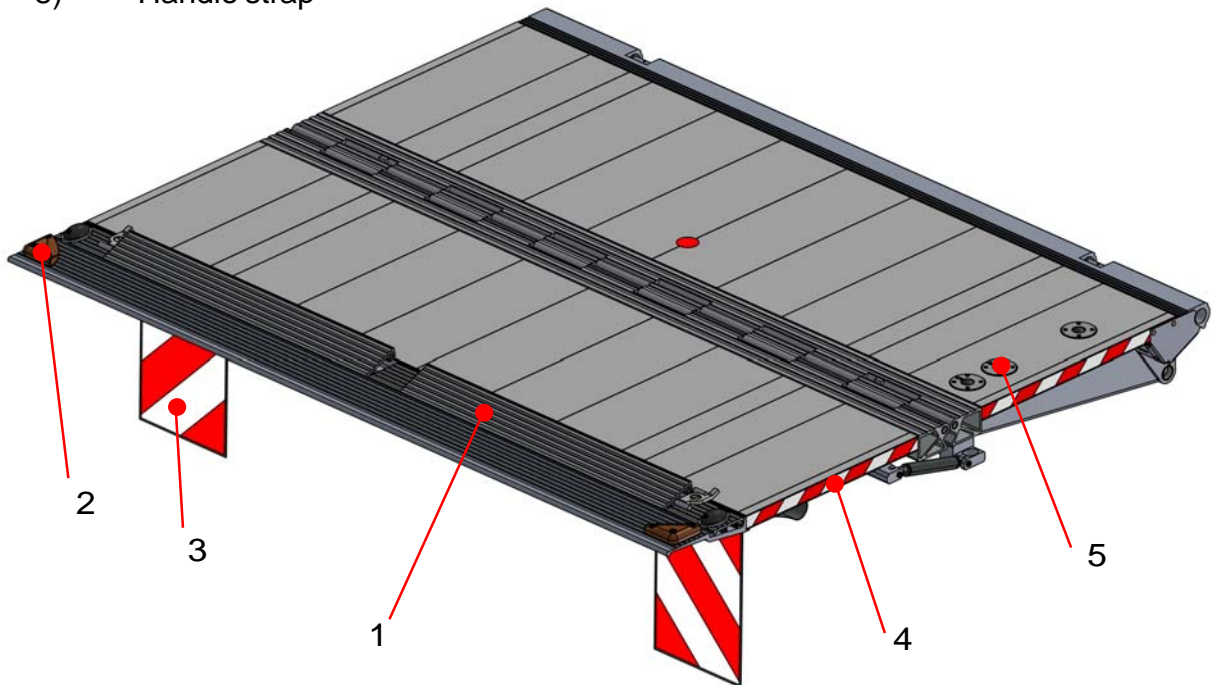

RECOMMENDED DAILY OPERATION CHECKS

NOTE: Before you check the Liftgate, park vehicle on flat ground and set the parking brake.

NOTE: If any of the following operation checks reveal a need to service or repair Liftgate, do not operate the Liftgate until a qualified mechanic services or repairs the Liftgate.

Before operating the Liftgate, the operator should do the following:

- Make sure battery is fully charged and battery terminal connections are clean and tight.
- Make sure cab cutoff switch is **ON**, if equipped.
- Visually check that pump cover is bolted on securely and undamaged. Look for hydraulic fluid leaking from the pump box.
- Visually check that control switch and guard are in place and undamaged.
- Visually check for cracks and bends on the extension plate. Also, make sure fasteners are in place and undamaged and extension plate is clean (no oil, debris, or corrosion).
- Visually check that all decals are in place (see **DECALS** page). Make sure decals are legible, clean, and undamaged.

Use the operation instructions in this manual to lower the Liftgate to the ground and open the platform and flipover.

- Check main frame, lift arms, parallel arms and platform openers for cracks and bends. Make sure rollers, on the platform openers, roll freely. Also, make sure all bolts and pins are in place and undamaged.
- Make sure main frame, lift arms, parallel arms and platform openers are clean (no oil, debris, or corrosion).
- Check the hydraulic cylinders for leaking seals and hose connections. Follow the hydraulic hoses (or return lines for gravity down Liftgates) from the cylinders to pump box. Make sure all hoses are connected at both ends and there are no cracks, chafing, and fluid leaks.

RECOMMENDED DAILY OPERATION CHECKS

- With the platform unfolded and raised to bed level, check if the outboard edge of platform is level or rises up to 1" above bed level (**YES illustration**). If the outboard edge of platform looks like the **YES illustration**, you can operate Liftgate. If the outboard edge of platform is below level line and platform looks like the **NO illustration**, do not operate the Liftgate. (See **NOTE** at beginning of the **DAILY OPERATION CHECKS**.)

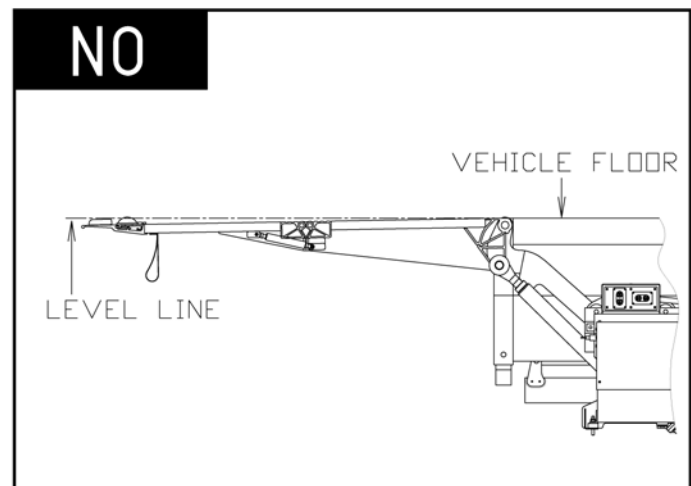
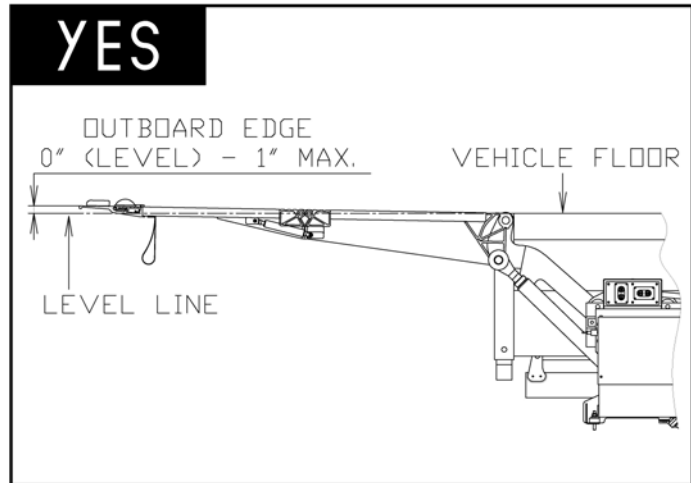

- Check the platform and flipover for cracks, holes, and bends on the load-carrying surface and side plates. Also, make sure torsion bars, coil springs, and fasteners are in place and undamaged.
- Make sure platform and flipover load-carrying surfaces are clean (no oil, debris, or corrosion).

Use the operation instructions in this manual to operate the Liftgate through one cycle without a load on the platform. Raise the platform to vehicle bed height. Next, lower the platform to ground level.

- When the Liftgate is moving, listen for unusual noises and look for a "jerking" motion or uneven movement on either side of the platform.

If service or repairs are not required (or if completed), stow the Liftgate.

OPERATING INSTRUCTIONS FOR THE "AHT" TAILGATE LOADER

The power pack is normally mounted on the curbside of the vehicle, on the cross beam. All control buttons are located on the control box. This control box is usually fix located on the curbside of the vehicle and mounted with the rail on the vehicle frame. A cab cut off switch can be placed in the cab to switch off the current to the control buttons.

CAUTION: Be sure there is enough room for the operator to safely operate the "AHT".

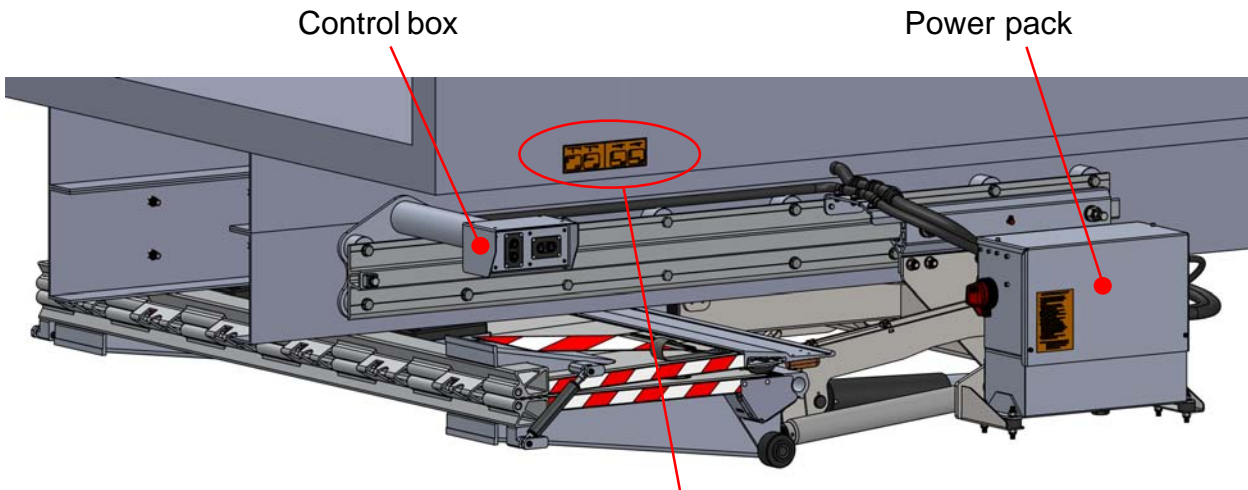

Label for operating the control buttons

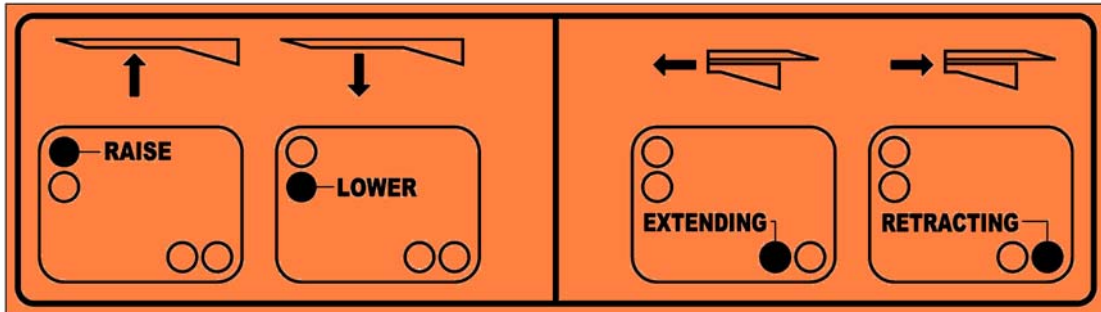

1) ENERGIZING THE „AHT“:

Turn the red switch clockwise. (If a cab cut off switch is installed, turn it also on.)

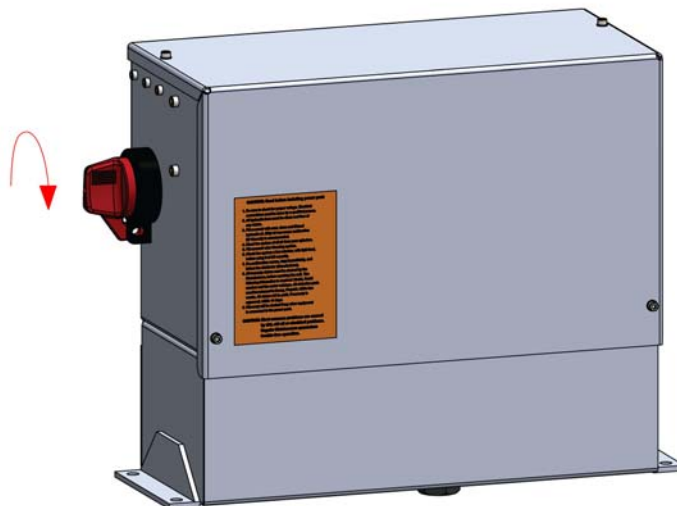

OPERATING INSTRUCTIONS FOR THE "AHT" TAILGATE LOADER

2) SLIDING THE „AHT“ TO THE OUT POSITION:

Press the **LOWER** button, momentarily, so the tailgate loader can be moved outward.

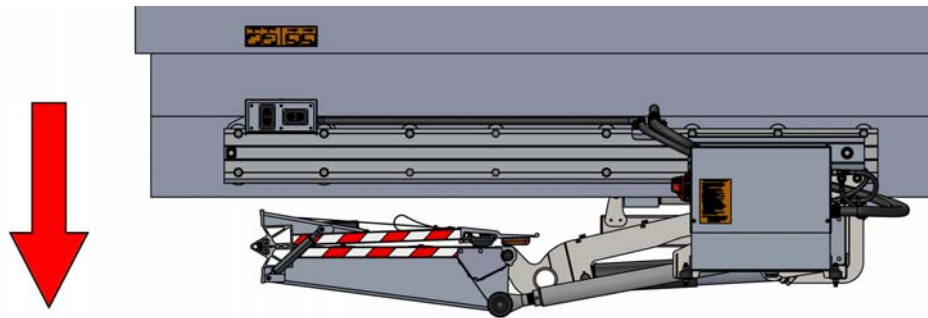

Press the **EXTENDING** button to slide the tailgate loader to the outer most position. (Against the endstop cube)

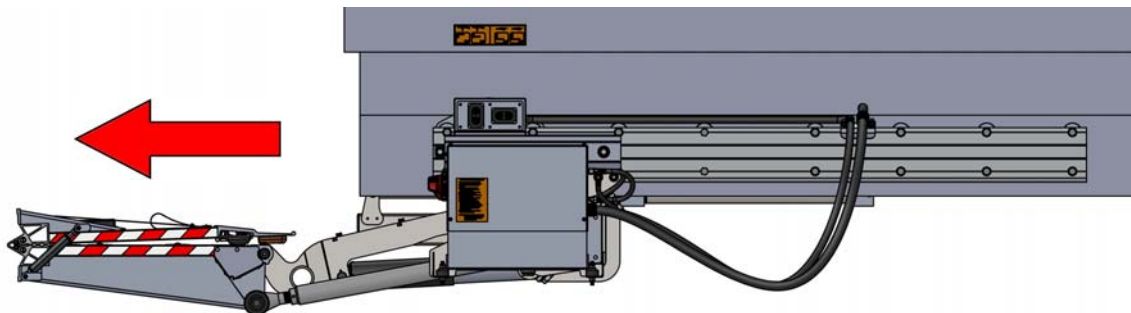

CAUTION: Always be sure the area behind the vehicle is clear and safe. Also be sure no one is standing in or near the platform working area.

OPERATING INSTRUCTIONS FOR THE “AHT” TAILGATE LOADER

3) OPENING THE FOLDED PLATFORM:

Open the folded platform **manually** and the tailgate loader is ready to work.

CAUTION: If the platform tip does not clear the vehicle frame, then it is necessary to lower the platform until the tip clears the vehicle frame. Care should be taken when opening the platform manually. The operator must stand in a good lifting position and have both hands available to open the platform. Do not drop the platform as it will eventually become damaged.

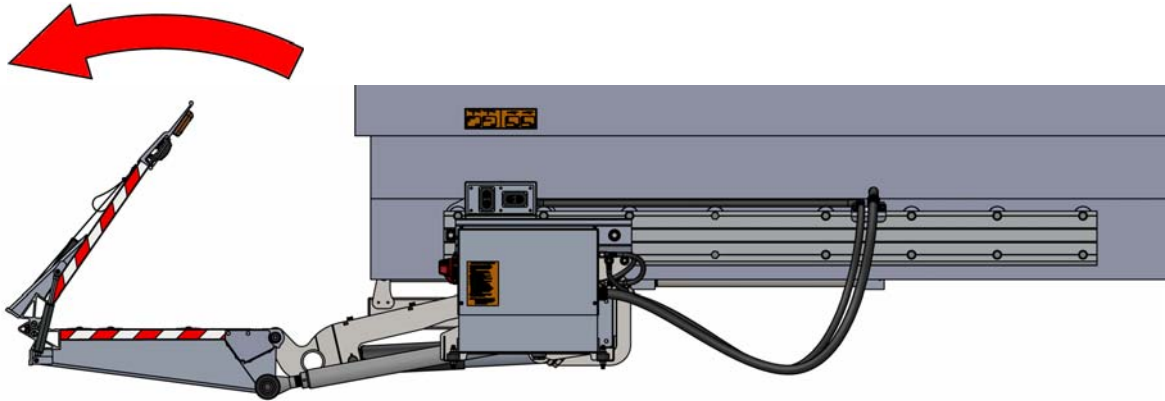

NOTE: Tip of platform should be 2° above level to compensate for the load.

The platform will maintain this level all the way up and down.

If you want to change the position of the tip, you must adjust the lever arm manually as described in installation manual.

4) LOWERING THE PLATFORM:

Press the **LOWER** button to lower the platform.

CAUTION: Always consult the data plate to be sure you are not overloading the platform. Always consider the weight of the pallet jack, pallet and the person. Load must always be centred on the platform and as close to the truck as possible.

If you want to change the lowering speed of the platform, you must readjust the flow control valve located in the power pack.

(Ask your supervisor for the correct instructions).

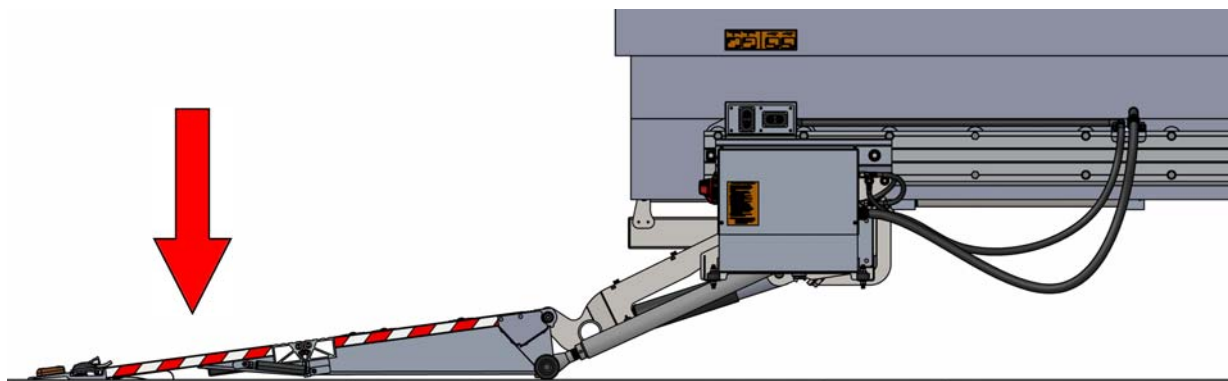

OPERATING INSTRUCTIONS FOR THE “AHT” TAILGATE LOADER

5) LIFTING THE PLATFORM:

Press the **RAISE** button to raise the platform. The platform tip will level automatically.

CAUTION: Always consult the data plate to be sure you are not overloading the platform. Always consider the weight of the pallet jack, pallet and the person. Load must always be centred on the platform and as close to the truck as possible.



DO NOT STAND ON TIP OF PLATFORM WHILE OPERATING.

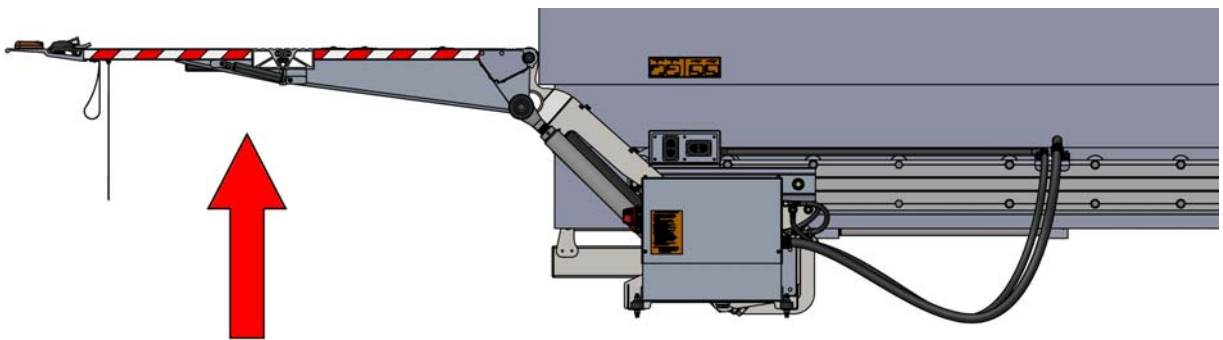

6) SLIDING THE „AHT“ TO THE TRAVELING POSITION:

Fold the platform carefully.

CAUTION: Care should be taken when closing the platform manually. The operator must stand in a good position and have both hands available to close the platform. Do not drop the platform as it will eventually become damaged.

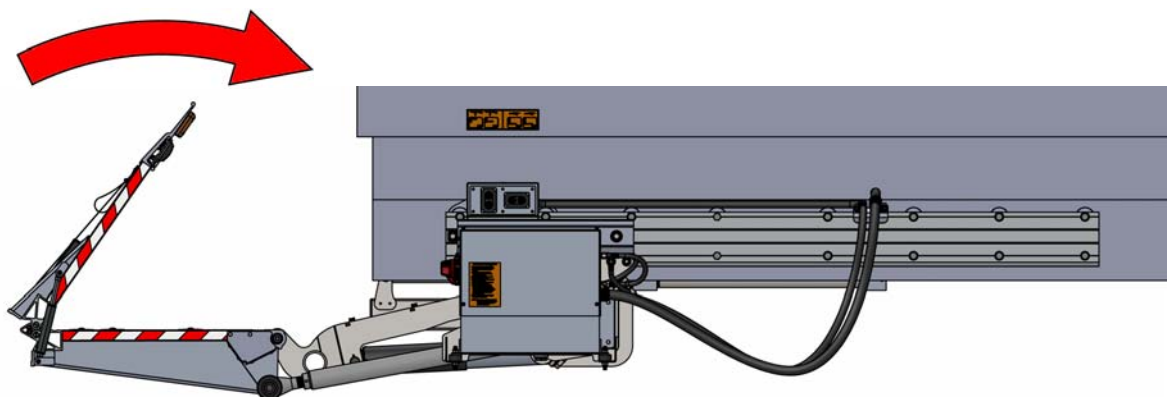

OPERATING INSTRUCTIONS FOR THE “AHT” TAILGATE LOADER

Lift the platform to the correct entry height for retracting and secure the tailgate loader.

Press the **RETRACTING** button to slide the tailgate loader to the full IN position.

CAUTION: Be careful while sliding the tailgate loader into the travel position. It must not interfere with any object and become damaged.

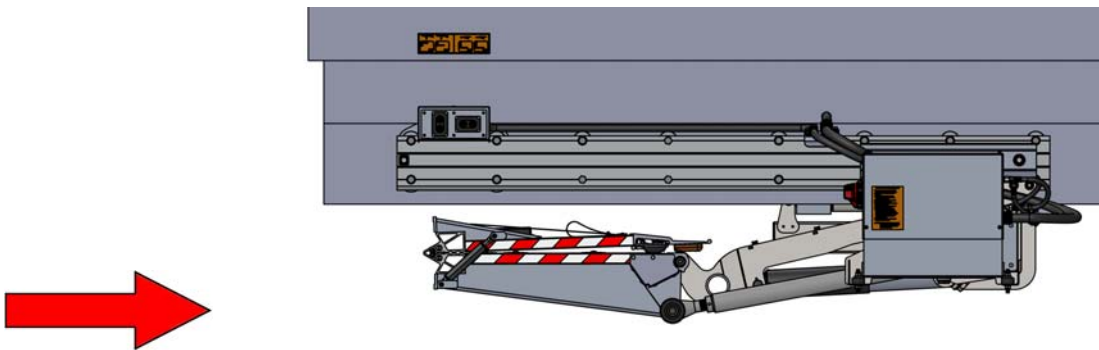

When the tailgate loader is in the traveling position, press the **RAISE** button until the tailgate loader will make contact with the rubber bumper.

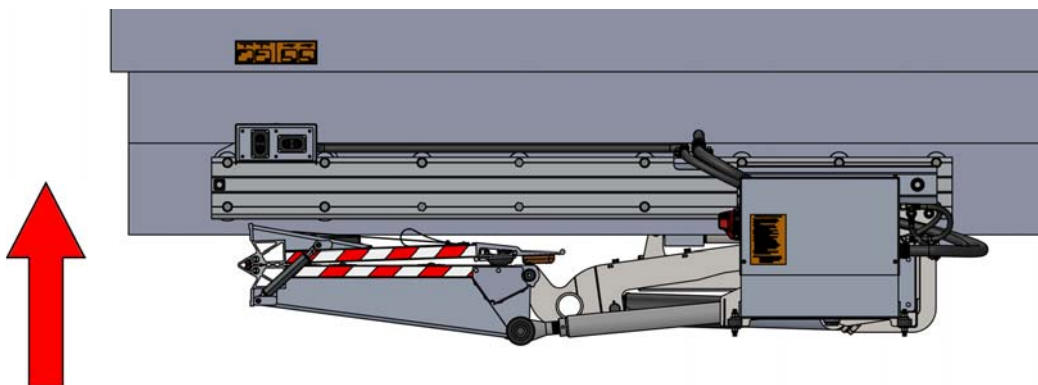

OPERATING INSTRUCTIONS FOR THE “AHT” TAILGATE LOADER

7) TURN OFF THE “AHT”:

Turn the red switch counter-clockwise. This removes all electrical current from the tailgate loader.

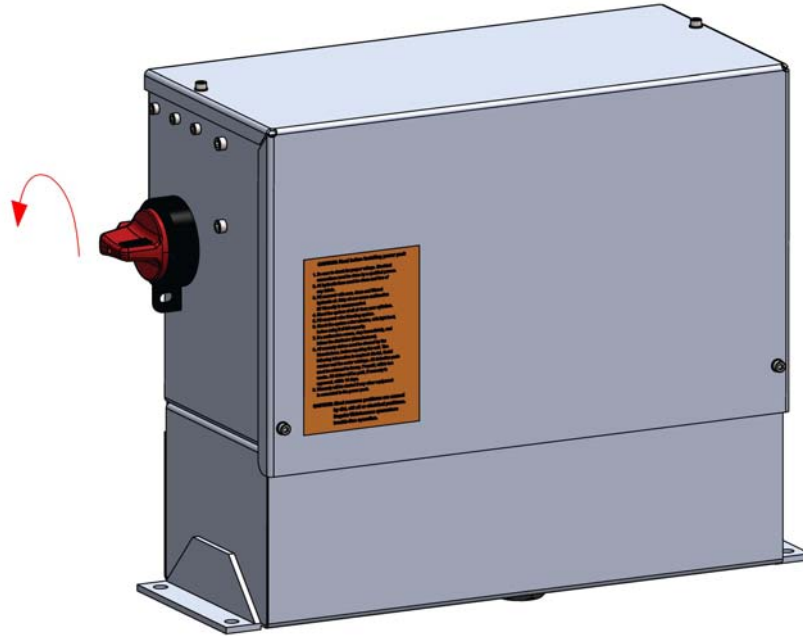

OPERATING INSTRUCTIONS FOR THE “AHT” TAILGATE LOADER

Using the 3-button foot control:

The 3-button foot control is built into the platform. It is only possible to ride up and down using the foot controls. At ground level, continue to hold the LOWER button, and the SAFETY button, and the platform will tilt down to unload the product.

CAUTION: Be sure that there is enough room, and a safe place, for the operator to ride up and down on the platform.

Operator should hold onto a safety device, attached to the van body, for safety.

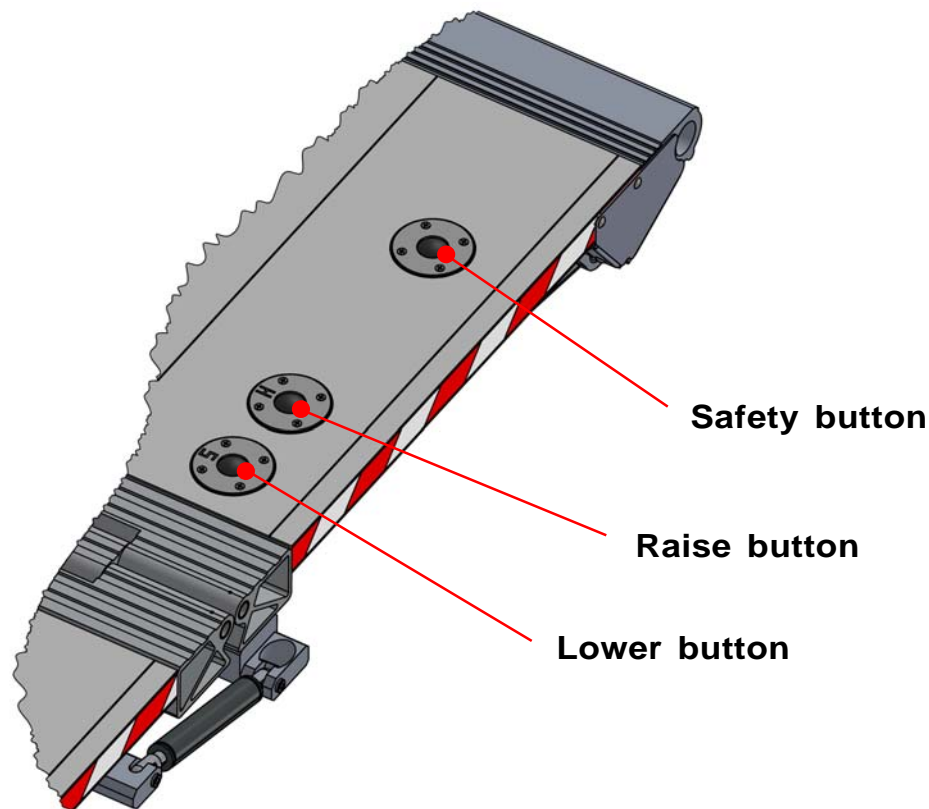

Safety button:

The “AHT” tailgate loader will not operate without pushing the safety button. (Required in Europe)

Raise button:

For lifting the platform, at ground level, push the **RAISE** button. The platform will return to your preset level and then rise to your preferred height, up to vehicle bed level.

Lower button:

For lowering the platform to ground level, push the **LOWER** button. When the wear rollers touch the ground, and the operator continue to press the **LOWER** button, the platform will automatically tilt to ground level to remove the product.

SAFETY INSTRUCTIONS FOR THE “AHT” TAILGATE LOADER

If you **ride on the platform**, using the 3-button foot control, you should always be very careful to follow these rules:

- 1) Be sure to wear good shoes. No hard or rubber soles.
- 2) Do not horse play on the platform. Always be very conscience for your safety.
- 3) **Be sure there is enough room for the operator** to safely operate the AHT.
- 4) When operating the AHT, and riding on the platform, it is important to hold onto the vehicle to prevent falling.

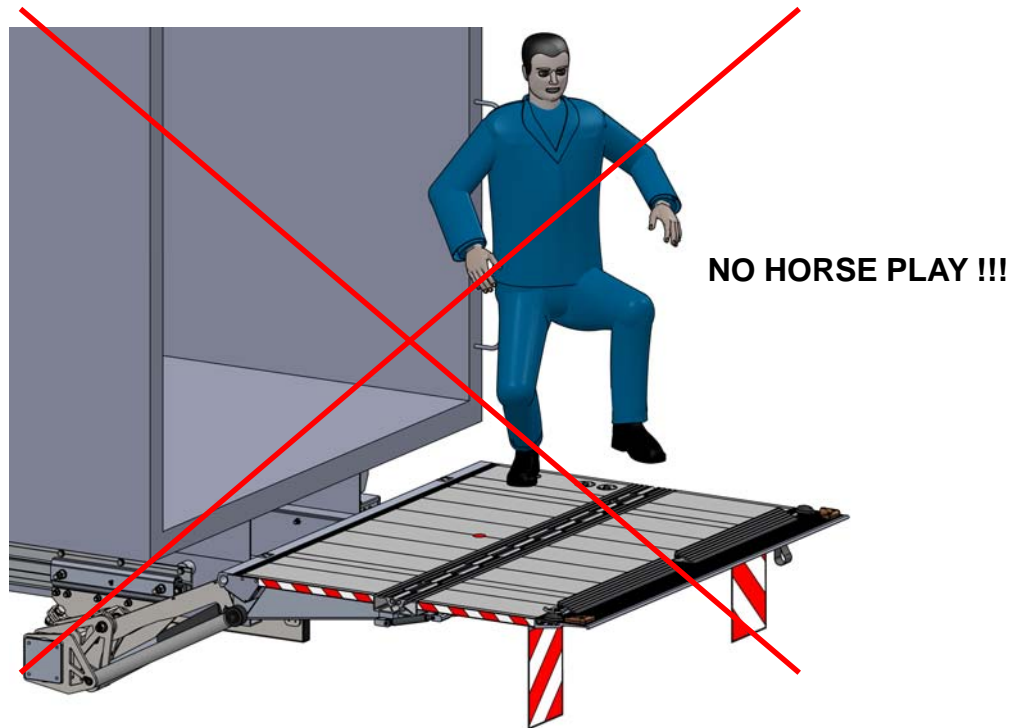

Never place **your foot outside** of the **platform**. Your foot could be crushed.

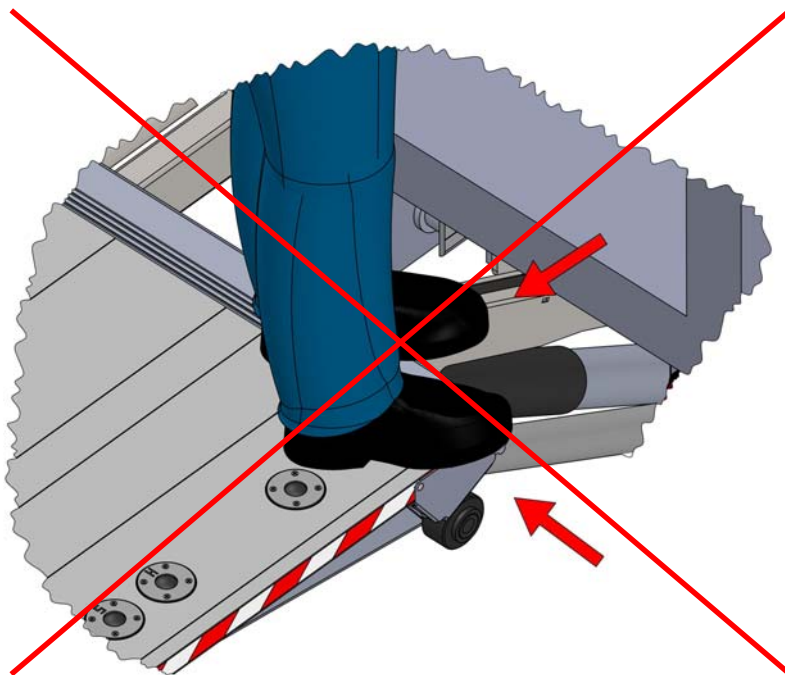

SAFETY INSTRUCTIONS FOR THE “AHT” TAILGATE LOADER

The operator should always hold onto a safety device while riding the platform.

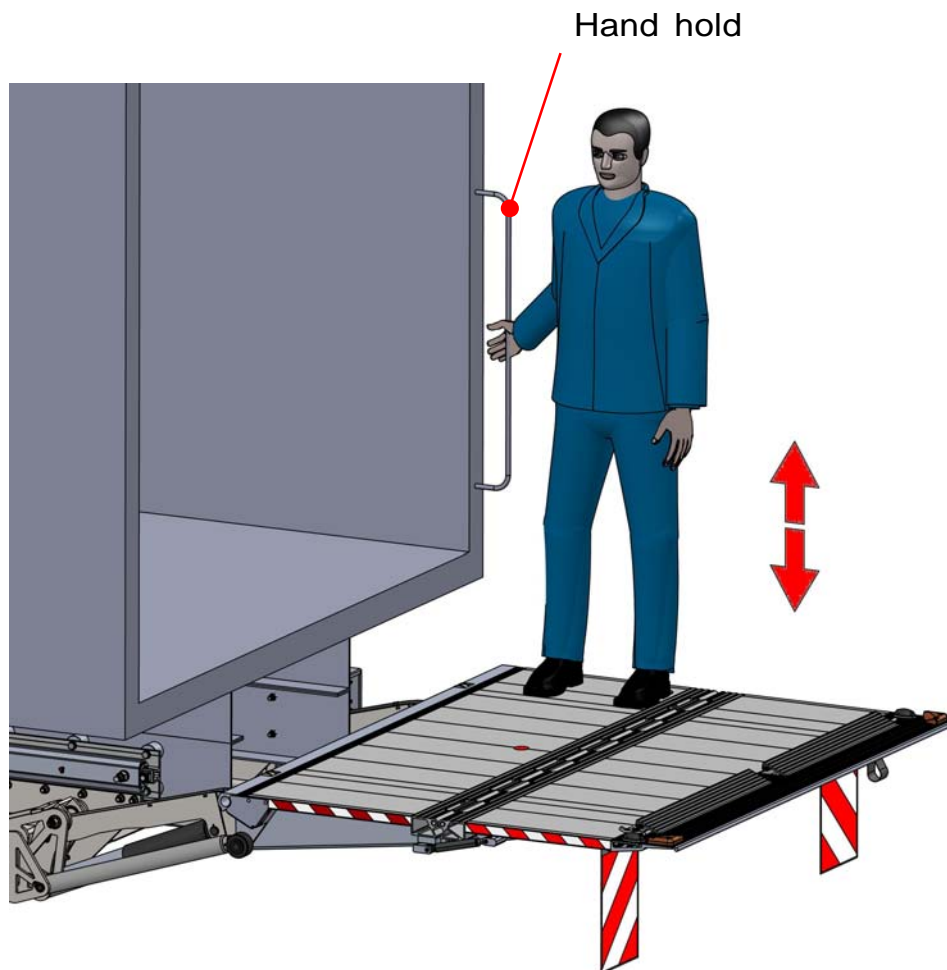

CENTER OF GRAVITY AND LOADING DIAGRAM

- 1) Be sure driver and/or operator is well trained and should familiarise himself with the operating the „AHT“ before using the tailgate loader. A good training session will save a lot of heartaches later.
- 2) Please be conscious of the total lifting capacity of the “AHT”

Product	Pounds	Kilogram
One person	198	90
Pallet Jack	176	80
Pallet	66	30
Product	???	???

- 3) Total weight should be **equal** to the lifting capacity of the “AHT” or **less**.
- 4) Please consult the data plate on your “AHT” tailgate loader to be sure the maximum capacity is not exceeded.

3300	1980	1320	924	660	Lbs
1500	900	600	420	300	kg
60	90	120	150	180	cm
23.62	35.43	47.24	59.06	70.87	inch

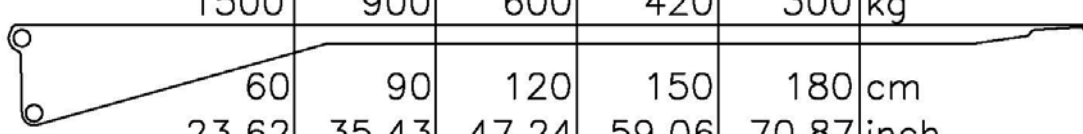

Do not operate the “AHT” tailgate loader until you have read the operation manual!

GENERAL OPERATING AND MAINTENANCE INSTRUCTIONS

Hydraulic equipment is usually a part of another piece of equipment, such as a truck. To ensure a long and trouble free operation, always read the manufacturers instructions carefully.

Below is a short list of “Do’s” and “Don’ts”

DO’s:

- When mounting the power pack, make sure it is level to the frame and has easy access for filling the reservoir, doing maintenance, etc.
- The satisfactory functioning, long life, reliability and efficiency of hydraulic equipment is greatly affected by the selection of the most suitable type of hydraulic fluid. We highly recommend hydraulic oil with 22 viscosity.
- In case of very low temperature, less than 0°C (+32°F), use oil with a 10 viscosity.
- Fill the reservoir with a good grade of hydraulic oil. Always use a filtered funnel and clean oil.
- The „AHT“ tailgate loader will permit the use of normal hydraulic oil.

DON'Ts:

- **NEVER** work on the hydraulic system while it is under pressure.
- **NEVER** use tape or pipe dope on the hydraulic fittings. They will seal without any outside help.
- **NEVER** use automatic transmission fluid.
- **VERY IMPORTANT:** If you wish to paint the equipment or weld on it, always mask off all moving parts, flexible connections and nameplates before doing so.

CAUTION: When the “AHT” tailgate loader is steam cleaned, it is very important to be careful around the electrical control box. **DO NOT** point the steam directly at the power pack and control box housing, as the electrical connections are delicate and could be damaged. It is also very important to lubricate the entire unit, after washing, as the grease has been washed away.

SERVICING THE „AHT“ TAILGATE LOADER

Three types of checks need to be made on a regular basis.

- The daily check
- The monthly check
- The annual check

(Report any defects to your supervisor immediately)

*THE DAILY CHECK:

Check all bolts and pins for tightness.

Check for leaks, **under the vehicle**, and inside the hydraulic system.

Check the switches, RAISE, LOWER, EXTENDING and RETRACTING for proper operation.

Check the hydraulic oil level, if any leaks are apparent.

The platform must be completely on the ground and retracted to check the proper oil level (All cylinders must be retracted completely)

*THE MONTHLY CHECK:

Complete the daily check, plus the following:

Pressure wash the entire unit, being careful not to pressure wash inside the power pack and control box.

Check all bolts for looseness and tighten if necessary.

Check all welds for cracks and repair if necessary.

Lubricate all grease fittings.

Replace any worn or broken parts

Check the lowering speed (**Be sure it is safe**)

Check the oil level, and add if necessary (**Do not overfill**)

*THE ANNUAL CHECK:

Complete the daily check

Complete the monthly check, plus the following:

Check all electrical cables for chafing or breaking, repair if necessary

Check all hydraulic lines for leaks, cracks or chafing, repair if necessary

Drain the hydraulic reservoir; clean the filter and the reservoir

Fill reservoir with a good, clean grade of hydraulic oil. (22 viscosity)

Check the lifting capacity (Consult the data plate for correct capacity of this unit)

Check all safety devices (Flags, Roll stops, etc.) for proper operation

Check the wear plates and/or rollers and replace, if necessary

Check all electrical connections for corrosion and tightness. Repair if necessary

Note: Depending on frequency of use, the hydraulic hoses should be changed after approximately three years.

Only **clean** hydraulic oil will allow proper operation of your equipment.

The hydraulic oil **should** be changed once a year. The power pack requests oil of 22cst (usage of 10cst oil during very low temperatures, under minus 10°C).

Oil	Operating temperature
HLP10	-25°C to 50°C
HLP15	-20°C to 60°C
HLP22	-10°C to 80°C

AHT WARRANTY CERTIFICATE

AHT warrants to the original purchaser, for a period of TWO YEARS all manufactured parts and ONE YEAR for supplier parts, from the date of installation, any new AHT product, including accessories and/or spare parts. These items are warranted against defects in material and/or workmanship. AHT will, at its own discretion, either repair or replace any defective parts with equivalent parts, subject to the conditions listed below.

Type: **ULTK-1500ST/AL** Serial #: **10473-10492** Year of Mfg: **08/20**
Customers Name: _____ Date of Installation: _____

1. Replacement or repair of parts will be provided from the factory, subject to any applicable Federal, State or Local taxes. Labor charges are not covered unless specifically authorized by AHT, prior to the actual repair and subject to our published flat rate schedule.
2. Defective parts must be reported to AHT within 30 days of discovery and must be submitted on an official warranty claim form, or the warranty is void.
3. Warranty is valid only if the Warranty Registration Form is returned, within 15 days of installation, to AHT.
4. Warranty shall not apply if equipment is operated at capacities in excess of factory recommendations.
5. Warranty does not apply to defects caused by accident, misuse, alterations of design, improper installation, poor maintenance practices, or any other cause beyond the control of AHT.
6. Warranty shall not apply to any cargo loss, loss of use, or any other incidental or consequential damages arising out of the use of this product, including travel time.
7. Warranty as provided herein shall be the purchaser's exclusive and limited remedy, and AHT shall not be liable for consequential or other damages.

IT IS EXPRESSLY UNDERSTOOD AND AGREED THAT THERE ARE NO WARRANTIES MADE BY THE MANUFACTURER OR ITS AGENTS, REPRESENTATIVES OR DEALERS, EITHER EXPRESSED, IMPLIED OR IMPLIED BY LAW, EXCEPT THOSE EXPRESSLY STATED HEREIN ABOVE IN THIS STANDARD LIMITED WARRANTY AGAINST DEFECTS IN MATERIAL AND WORKMANSHIP, AND THE MANUFACTURER AND ITS AGENTS, REPRESENTATIVES AND DEALERS SPECIFICALLY DISCLAIM ANY IMPLIED WARRANTY OF MERCHANTABILITY OR FITNESS FOR ANY PARTICULAR PURPOSE.



Customer

AHT Representative

MANUFACTURERS CONFORMATION DECLARATION

for partially assembled machinery and equipment as per EG-Directive 2006/42/EG

Manufacturer: AHT - Aluhebeteknik GmbH
Bahnstraße 34
A-2474 Gattendorf



Product: Electro-Hydraulic Tailgate Loader

Type: ULTK-1500ST/AL

Serial no.: 10473-10492

max. capacity: 1500 kg

max. hydraulic pressure: 190 bar

Description: Electro-Hydraulic Tailgate, installed on a vehicle for the purpose of loading and discharging of goods. The installation must comply with installation and operations manual.

Applied guidelines, standards and tests:

- Machinery guideline 2006/42/EG
- EN ISO 12100
- EN 1756-1
- Check of technical information's (calculation, drawings and electrical schematic)
- Practical function and load test
- Check and confirm operator and installation manuals

AHT GmbH confirms that the above mentioned; partially assembled tailgate loader does comply with machinery guideline 2006/42/EG.

The conformation declaration will void if alteration and changes are undertaken without the permission of the manufacturer.



Company*): Aluhebeteknik GmbH

Signature*): _____

Location/Date): Gattendorf, 25.08.2020

Name/Title*): Ing.Günter Weber / Company Manager

INSTALLATION DECLARATION

The authorized Installer declares that the above mentioned tailgate loader has been installed as per Aluhebeteknik guidelines and also complies with the vehicle manufacturers guidelines. Additionally was tested as per EN 1756-1 attachment H prior to operation.

Name/Address of the installation workshop):

Signature of the installer): _____

Location/Date): _____

Name of the installer): _____

*) Company; Name and title of person who is authorised to sign the declaration on behalf of AHT

INDEX

	Page
How to use the „AHT“ tailgate loader	2
User qualifications to operate the „AHT“ tailgate loader	2
Warnings	3
Tailgate terminology	4 - 5
Recommended daily operation checks	6 - 7
Operating instructions for the „AHT“ tailgate loader	8 - 14
Safety instructions for the „AHT“ tailgate loader	15 - 16
Center of gravity and loading diagram	17
General operating and maintenance instructions	18
Servicing the „AHT“ tailgate loader	19
AHT warranty certificate	20
Manufactures conformation declaration	21