

MAXON®

MAINTENANCE MANUAL

FOR THE “AHT TAILGATE LOADER” ULTK-1500ST/AL

for Serial Number:
10473-10492

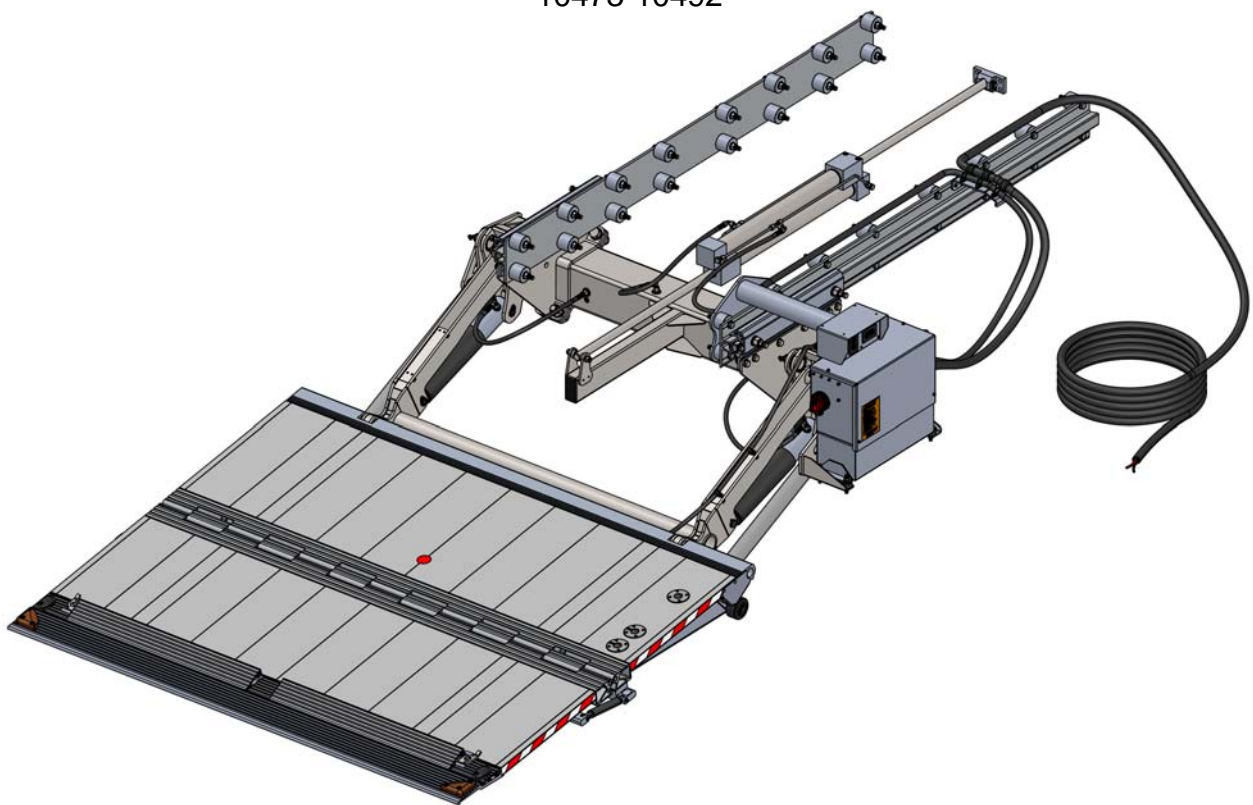

Designed for Maxon by:



Maxon Lift Corp. 11921 Slauson Ave., Santa Fe Springs, CA 90670
800.227.4116 Fax 888.771.7713, www.maxonlift.com

September 2020

HOW TO USE THE “AHT” TAILGATE LOADER

IT IS NOT PERMITTED TO USE THE “AHT” AS:

- A personal lift or elevator Only the operator is permitted to ride up and ride down with the load.
- As an extension of another body. Do not use the „AHT“ to load or unload another vehicle.
- As a car jack. It is very unsafe to lift another vehicle with the “AHT”
- As a snow plow. Heavy damage could be done to your new “AHT”

It is not permitted to overload the platform to a point where the operator does not have enough room to operate the tailgate safely.

USER QUALIFICATIONS TO OPERATE THE “AHT” TAILGATE LOADER

The driver and/or operator should be well trained and should familiar with the operating of the “AHT” before using the tailgate loader.

Carefully read the manual **before starting to operate** the “AHT” tailgate loader.

Only mature adults, age 18 and above, should operate the “AHT” tailgate loader.

The operator should never be under the influence of alcohol or drugs while operating the “AHT”.

The load **must be** stabilized on the platform to avoid damage to equipment or personnel.

The operator must never load or unload more than the maximum capacity of the “AHT” tailgate loader. **Read the data plate for actual capacity of this „AHT“.**

Always perform the daily check before using the „AHT“ tailgate loader.

SAFETY INSTRUCTIONS

- Read and understand the instructions in this **Maintenance Manual** before performing maintenance on the Liftgate.
- Before operating the Liftgate, read and understand the operating instructions in **Operation Manual**.
- Comply with all **WARNING** and instruction decals attached to the Liftgate.
- Keep decals clean and legible. If decals are illegible or missing, replace them. Free replacement decals are available from **Maxon Customer Service**.
- Consider the safety and location of bystanders and location of nearby objects when operating the Liftgate. Stand to one side of the platform while operating the Liftgate.
- Do not allow untrained persons to operate the Liftgate.
- Wear appropriate safety equipment such as protective eyeglasses, faceshield and clothing while performing maintenance on the Liftgate and handling the battery. Debris from drilling and contact with battery acid may injure unprotected eyes and skin.
- Be careful working by an automotive type battery. Make sure the work area is well ventilated and there are no flames or sparks near the battery. Never lay objects on the battery that can short the terminals together. If battery acid gets in your eyes, immediately seek first aid. If acid gets on your skin, immediately wash it off with soap and water.
- If an emergency situation arises (vehicle or Liftgate) while operating the Liftgate, release the control switch to stop the Liftgate.
- A correctly installed Liftgate operates smoothly and reasonably quiet. The only noticeable noise during operation comes from the power unit while the platform is raised. Listen for scraping, grating and binding noises and correct the problem before continuing to operate Liftgate.
- Use only **Maxon Authorized Parts** for replacement parts. Provide Liftgate model and serial number information with your parts order. Order replacement parts from:

MAXON LIFT CORP. Customer Service
11921 Slauson Ave., Santa Fe Springs, CA 90670
Online: www.maxonlift.com
Express Parts Ordering: Phone (800) 227-4116 ext. 4345
Email: Ask your Customer Service representative

PERIODIC MAINTENANCE

PERIODIC MAINTENANCE CHECKS

WARNING: Never operate the Liftgate if parts are loose or missing.

NOTE: Make sure vehicle is parked on level ground while performing the maintenance checks.

Quarterly or 1250 Cycles (whichever occurs first)

Check the hydraulic fluid level in the pump reservoir. Refer to the **CHECKING HYDRAULIC FLUID** procedure in the **PERIODIC MAINTENANCE** section.

If hydraulic fluid appears contaminated, refer to the **CHANGING HYDRAULIC FLUID** procedure in the **PERIODIC MAINTENANCE** section.

Keep track of the grade of hydraulic fluid in the pump reservoir and never mix two different grades of fluid.

Check all hoses and fittings for chafing and fluid leaks. Tighten loose fittings or replace parts as required.

Check electrical wiring for chafing and make sure wiring connections are tight and free of corrosion. Use dielectric grease to protect electrical connections.

Check that all **WARNING and instruction decals** are in place. Also, make sure decals are legible, clean and undamaged.

Check that all bolts, nuts, and roll pins are in place. Make sure roll pins protrude evenly from both sides of hinge pin collar. Replace fasteners and roll pins if necessary.

Pump EP chassis grease in each lube fitting on the cylinders and arms until grease starts oozing from ends of the bearings. The lubrication diagram on the **PERIODIC MAINTENANCE CHECKLIST SHEET** shows where to find the lube fittings. Wipe off excess grease with a clean lint-free cloth.

CAUTION: Damaged cylinder seals and contaminated hydraulic fluid can result from painting the polished portion of the cylinder rod. To prevent damage, protect the exposed polished portion of the cylinder rod while painting.

Check for rust and oily surfaces on Liftgate. If there is rust or oil on Liftgate, clean it off. Touch up the paint where bare metal is showing. MAXON recommends using the aluminum primer touchup paint kit, P/N 908134-01.

Semi-annually or 2500 Cycles (whichever occurs first)

Visually check the platform hinge pins for excessive wear and broken welds. See **PARTS BREAKDOWN** section for replacement parts. Also, do the **Quarterly or 1250 Cycles** maintenance checks.

PERIODIC MAINTENANCE CHECKLIST

NOTE: Make sure vehicle is parked on level ground while performing the maintenance checks.

Quarterly or 1250 Cycles (whichever occurs first)

- Check the level and condition of the hydraulic fluid.
- Visually check all hoses and fittings for chafing and fluid leaks. Tighten loose fittings or replace parts as required.
- Check electrical wiring for chafing and make sure wiring connections are tight and free of corrosion. Use dielectric grease to protect electrical connections.
- Check that all **WARNING and instruction decals** are in place. Also, make sure decals are legible, clean, and undamaged.
- Check that all bolts, nuts, and roll pins are in place. Make sure roll pins protrude evenly from both sides of hinge pin collar. Replace fasteners and roll pins if necessary.
- Check for rust and oily surfaces on Liftgate. If there is rust or oil on Liftgate or if the Liftgate is dirty, clean it off. Touch up the paint where bare metal is showing. Refer to the paint system **CAUTION** and recommended touchup kit on the preceding page.
- Pump EP chassis grease in each lube fitting on the cylinders and arms until grease starts oozing from ends of the bearings. Refer to lubrication diagram on the next page. Wipe off excess grease with a clean lint-free cloth.

Semi-annually or 2500 Cycles (whichever occurs first)

- Visually check the platform hinge pins for excessive wear and broken welds.
- Do the **Quarterly or 1250 Cycles Checks** on this checklist.

TECHNICAL DESCRIPTION „AHT“ TAILGATE LOADER

The “AHT” tailgate loader has the following components:

- | | | | |
|-----|------------------|---------|------------------------|
| 1) | Cross beam | (ST) | ST... made of steel |
| 2) | Lift arm | (ST) | AL... made of aluminum |
| 3) | Platform | (AL) | |
| 4) | Sliding brackets | (ST/AL) | |
| 5) | Lift cylinders | (AL) | |
| 6) | Lever arms | (AL) | |
| 7) | Tilting brackets | (ST) | |
| 8) | Rails | (AL) | |
| 9) | Feed cylinder | (ST/AL) | |
| 10) | Hose guide | (AL) | |
| 11) | Power pack | (AL) | |
| 12) | Control box | (AL) | |

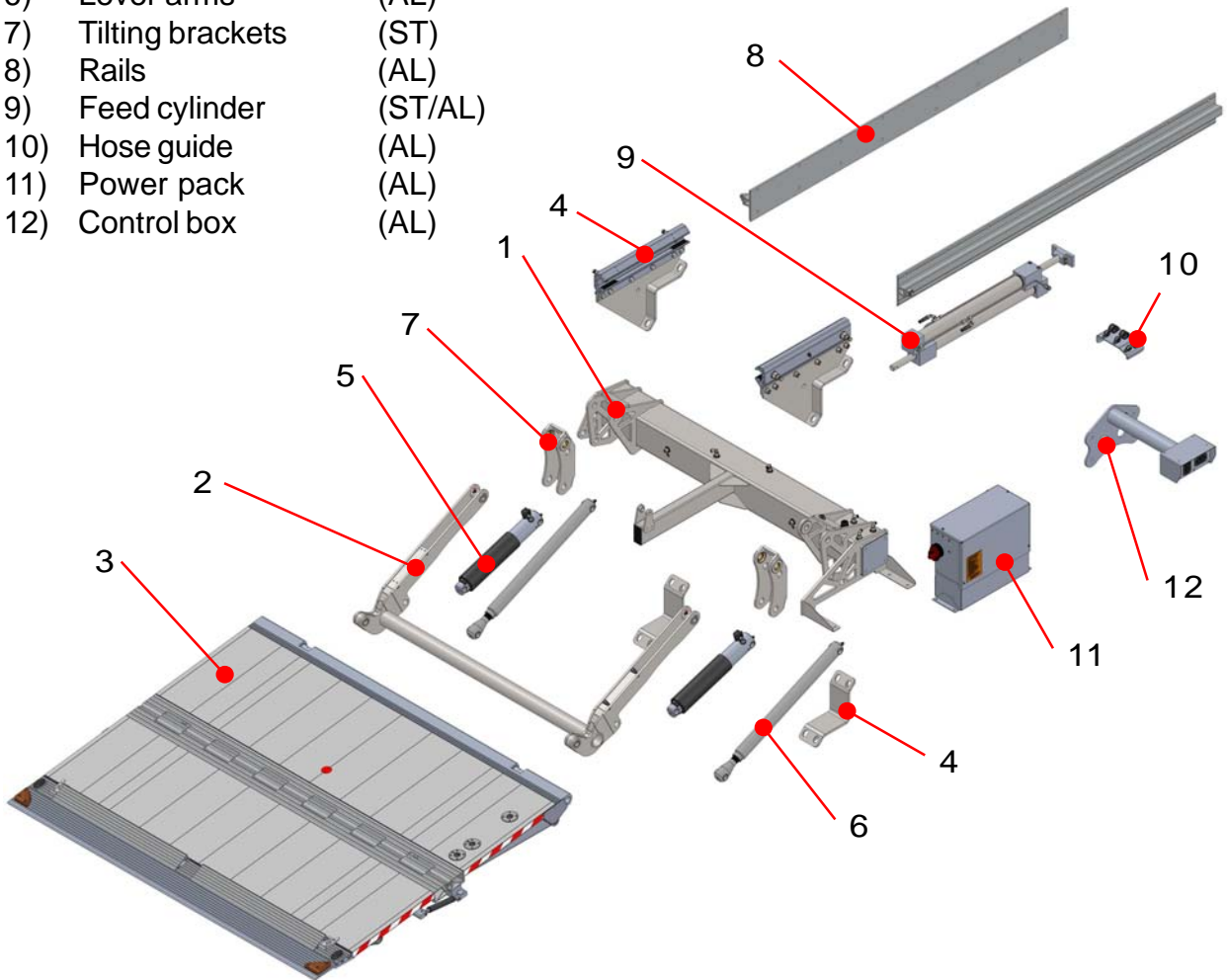

The cross beam (1) is mounted to the sliding rails (8) with the sliding brackets (4).

For lifting the load, we use two single-acting aluminum lift cylinders (5). All two cylinders have ceramic-coated, salt and chemical resistant, aluminum piston rods for ultra long life span.

Each of the two lift cylinders is equipped with a electrical hose burst valve for safety. In case of hydraulic hose failure, the platform (3) cannot fall to the ground. The failed hose can be replaced and the “AHT” can go back to work.

For extending and retracting the „AHT“ we use a double acting feed cylinder (9).

The platform tilting is manually adjustable with the lever arms (6).

If platform contacts the ground by lowering, the tilting brackets (7) tilts the platform tip to the ground.

TECHNICAL DESCRIPTION ALUMINUM PLATFORM

The platform is made from aluminum high strength profiles and is designed to maintain the load and keep it stabilized for your safety. The platform is folded for a smaller transporting length.

Safety options available for the all-aluminum "AHT" platform:

- 1) Spring loaded roll stops
- 2) Flashing lights for safety, when the "AHT" is being operated.
- 3) Safety flags so the platform can be seen from the rear while in operation.
- 4) Safety warning strips for the edge of platform.
- 5) Three button foot control (Required in EU countries)
- 6) Bumpers
- 7) Gas pressure springs
- 8) Handle strap

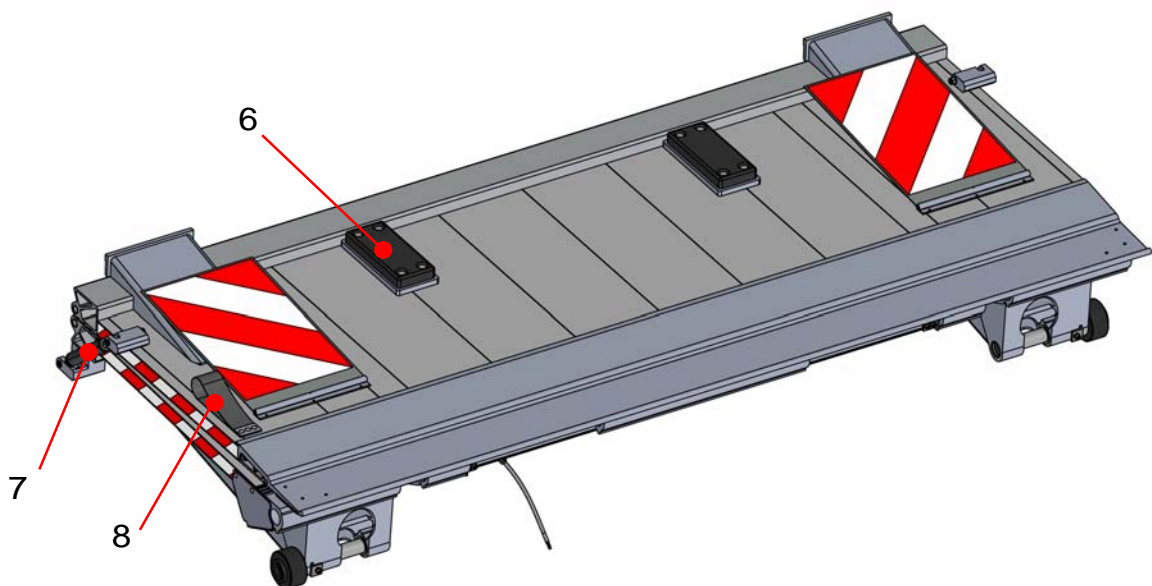
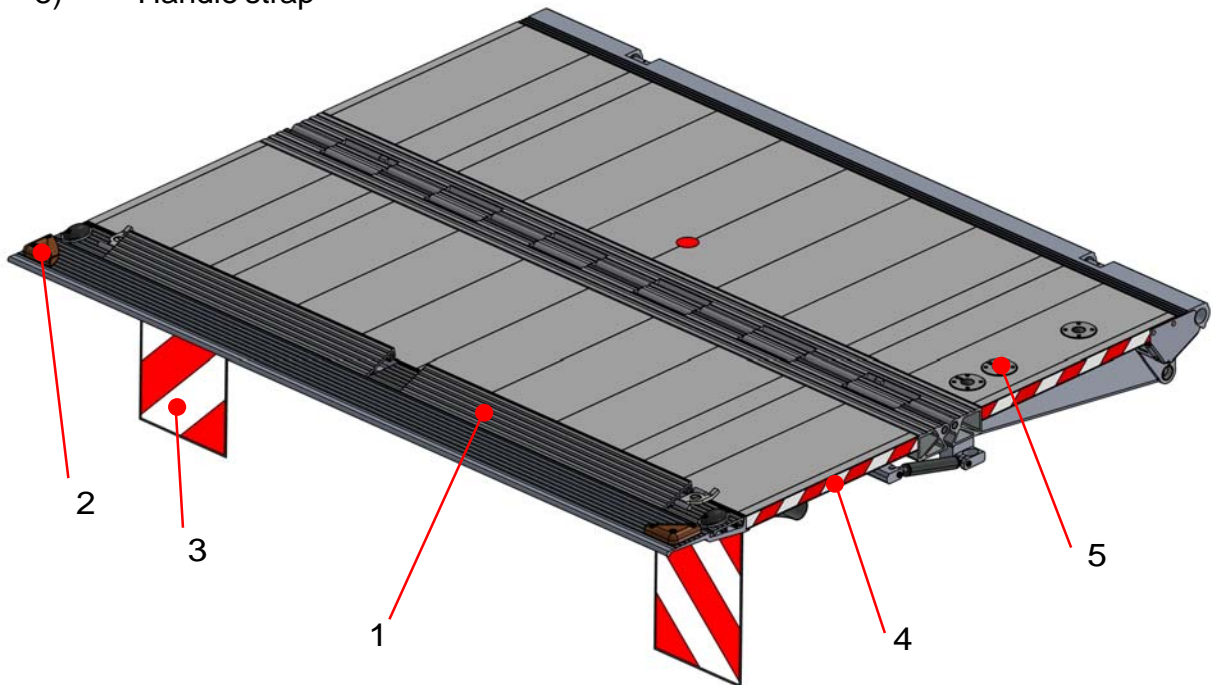

TECHNICAL DESCRIPTION

MHW POWER PACK AND CONTROL BOX

The MHW power pack enclosure, including the built-in oil reservoir, is made of aluminum and is insulated to achieve a very quiet operation. The **noise level** of the power pack is **less than <70dB** (MSV§74).

The power pack is usually located on the curbside of the vehicle and mounted on the cross beam. The adjustment for the working pressure and the lowering speed can only be done inside the power pack enclosure.

The control box is usually fix located on the curbside of the vehicle and mounted with the rail on the vehicle frame.

CAUTION: Never bottom out the relief valve fully. The power pack and/or the hydraulic system could be damaged. When the “AHT” is steam cleaned, it is very important to be careful around the electrical controls. **Do not point the steam directly at the power pack and control box housing, as the electrical connections are delicate and could be damaged.**

The power pack and control box contains the following components (outside):

- 1) Battery main switch
- 2) Cover for power pack
- 3) Oil drain plug
- 4) Buttons for operating
- 5) Cover for control box

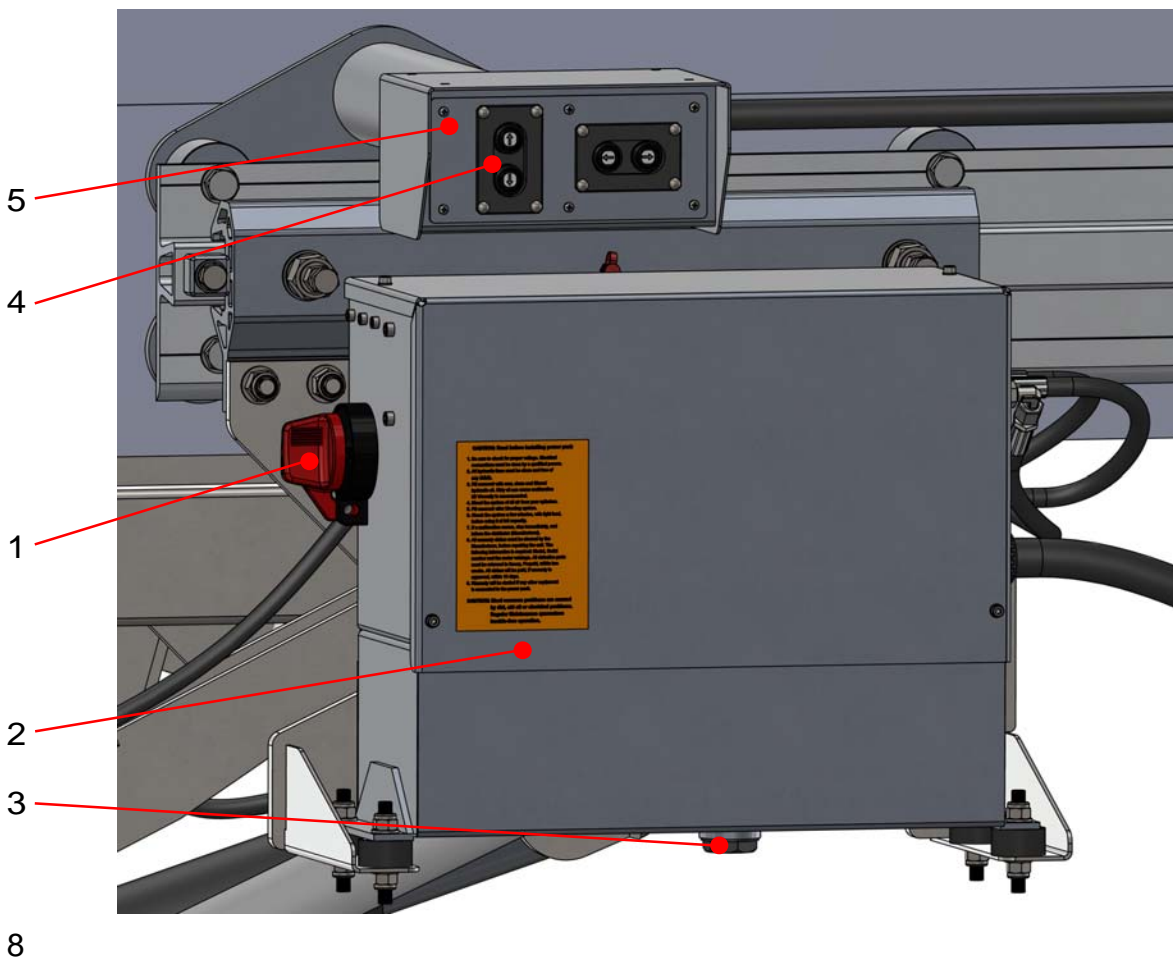

TECHNICAL DESCRIPTION FOR THE MHW POWER PACK

The MHW power pack contains the following components:

- | | | |
|-------|--|------------------------|
| 1) | Waterproof/Soundproof case for power pack | |
| 2) | Motor 12V 2kW | |
| 3) | Pump 1.6ccm | |
| 4) | Valve block MHW-VB-327 | |
| 4.1A) | LV - 2/2-Way valve with solenoid - lift circuit | |
| 4.1B) | FV - 2/2-Way valve with solenoid - feed cylinder | |
| 4.1C) | 4/2 - 4/2-Way valve with solenoid - feed cylinder in or out | |
| 4.2) | WV - Shuttle valve | |
| 4.3) | SV1 - Relief valve | |
| 4.4) | SV2 - Relief valve - feed cylinder out | 8) |
| 4.5) | MP - Test point plug | 9) |
| 4.6) | EMRV - Flow control valve - lift circuit | 10) |
| 4.7) | GRSV - Check valve pilot controlled | and cab cut off switch |
| 5) | Battery main switch | 11) |
| 6) | Starter solenoid | 12) |
| 7) | Relays for foot control | 13) |
| | | Fuse 12V - 25A |

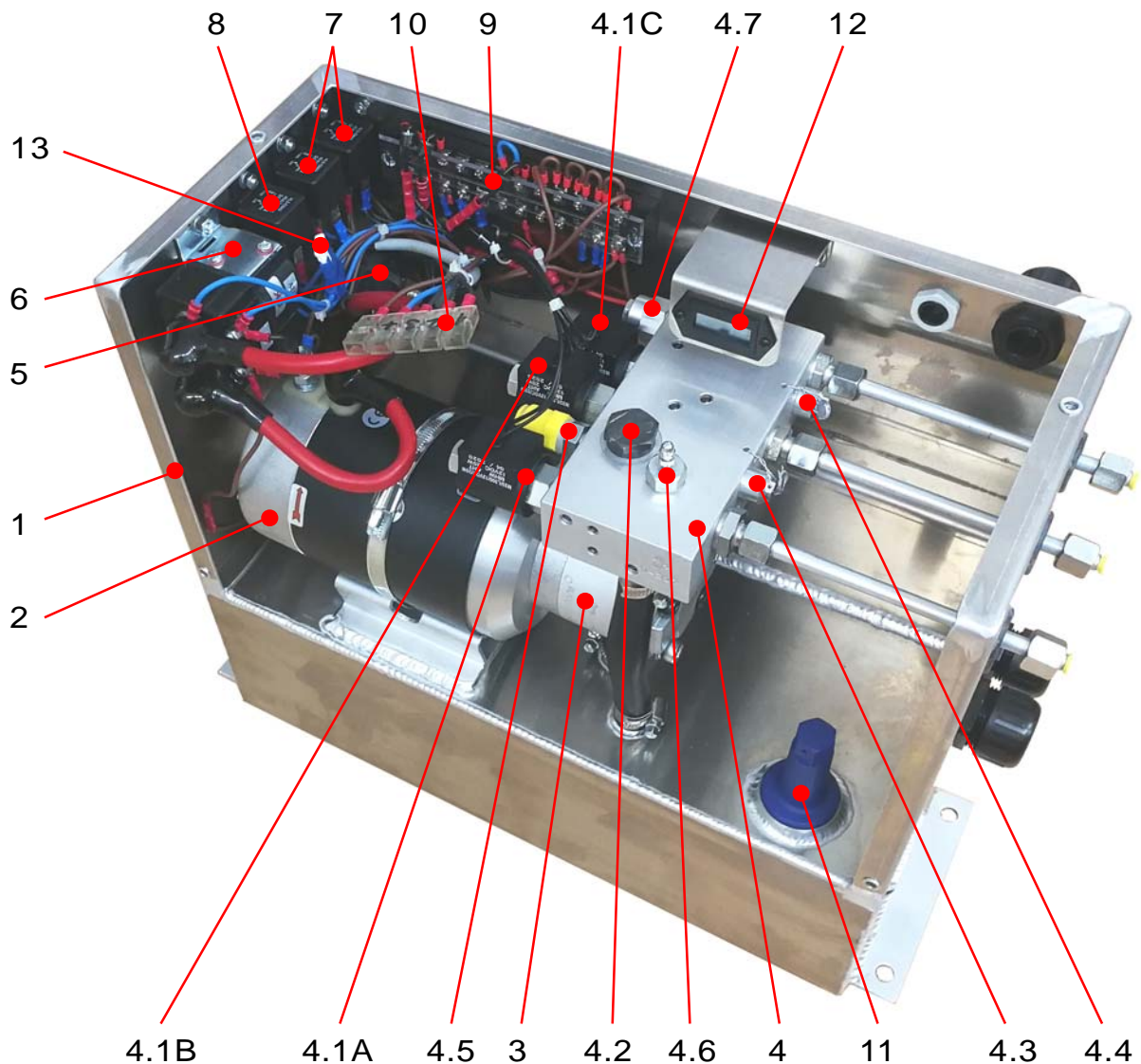

TECHNICAL DESCRIPTION FOR THE MHW POWER PACK

How to adjust the flow control valve

The lifting speed **is not adjustable**.

The extending and retracting speed **is not adjustable**.

The lowering speed **is adjusted by the flow control valve**. (pos. "EMRV")

How to adjust the flow control valve:

- Be sure the adjustable flow control valves are not closed. To regulate the lowering speed, first loosen the M4 (5/16") nut and adjust it carefully until the correct lowering speed is attained. When the speed is correct, hold the screw in one hand, lock the nut with the other. (max. 1.5Nm = 13lb-in)
- The **lowering speed** should be as follows:
Maximum lowering speed should be 6" (150mm) per second. (Maximum lowering speed is 50" in 8,5 seconds). (1270mm in 8,5 seconds)

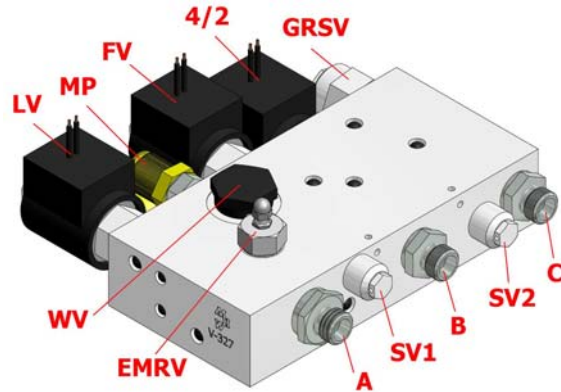

How to adjust the relief valve

The hydraulic pressure is adjusted by the relief valves. (pos. "SV1" & "SV2")

How to adjust the relief valves:

The relief valves are sealed at the factory. The seals **must not** be removed unless authorized by the factory. **Warranty is void if seal is broken.**

There are 2 different places to adjust the hydraulic pressure:

- 1) Relief valve "SV1" is to adjust the **LIFTING & RETRACTING** pressure.
Factory setting is 190 bar (2755 PSI).
- 2) Relief valve "SV2" is to adjust the **EXTENDING** pressure.
Factory setting is 80 bar (1160 PSI).

All relief valves are adjustable from 50-250 bar (725-3625PSI).

- Adjustment of the relief valve:
 - a) To adjust pressure, a **calibrated pressure gauge is required** and it should be connected at the test point (pos. "MP"). **NOTE: 1Bar equals 14.5PSI**
 - b) Remove the seal and cover from the adjusting nut.
 - c) Turn the adjusting screw with a hex wrench, **clockwise (for higher pressure) or counter-clockwise (for lower pressure)**. Be sure to keep an eye on the pressure gauge. The maximum pressure should not be set to more than 250 bar (3625 PSI).
 - d) When pressure is correct, lock the cap screw and **check the pressure again** to be sure it has not changed. Seal the cover.

CAUTION: Never bottom the relief valve. The power pack and/or hydraulic system could be damaged.

TECHNICAL DESCRIPTION MAXIMUM TORQUES

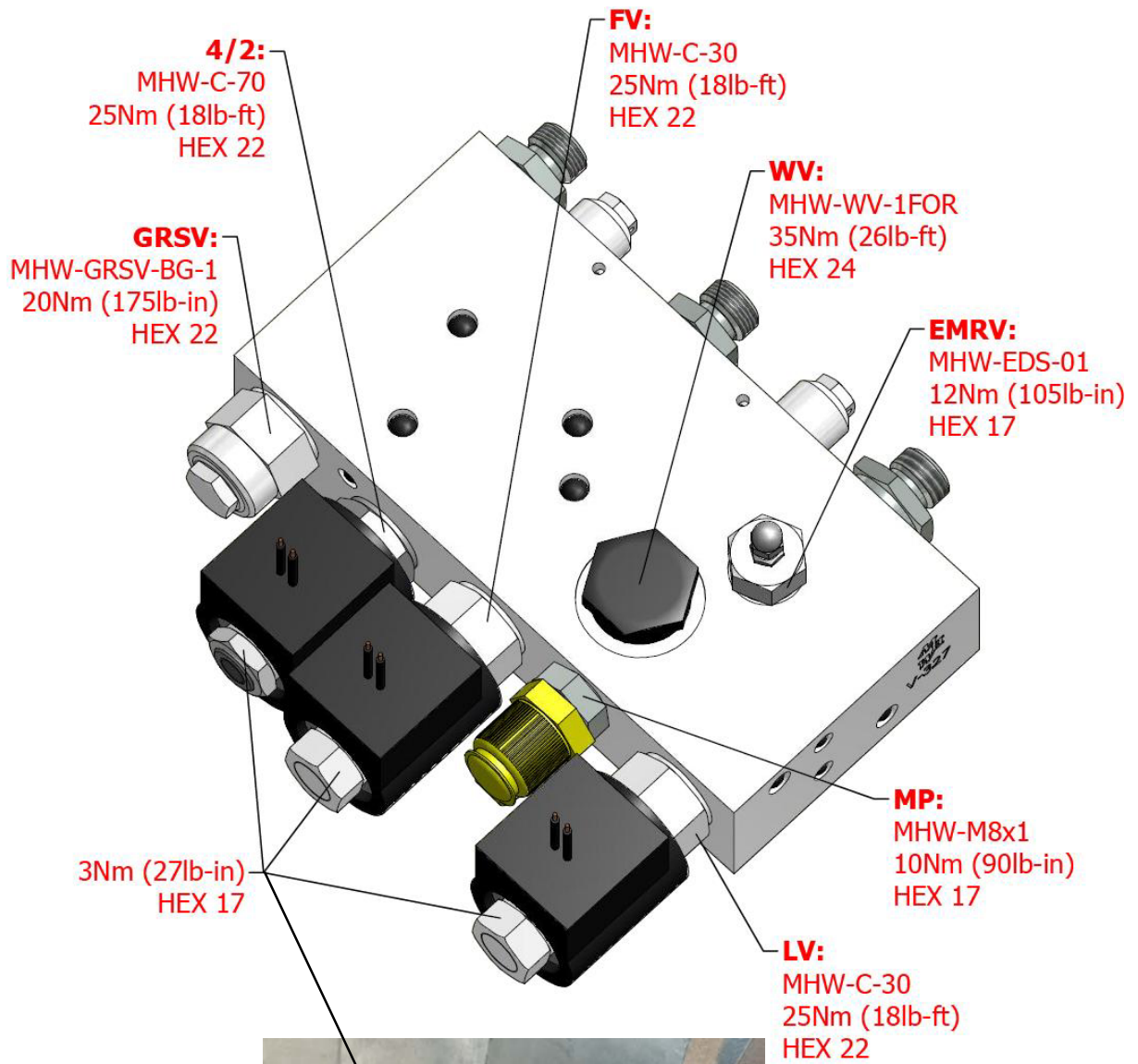

LCV:
MHW-C-10
25Nm (18lb-ft)
HEX 22



TECHNICAL DESCRIPTION

HOW TO CHANGE THE HYDRAULIC PUMP

- Remove the 2 screws to dismantle the original/defective pump.

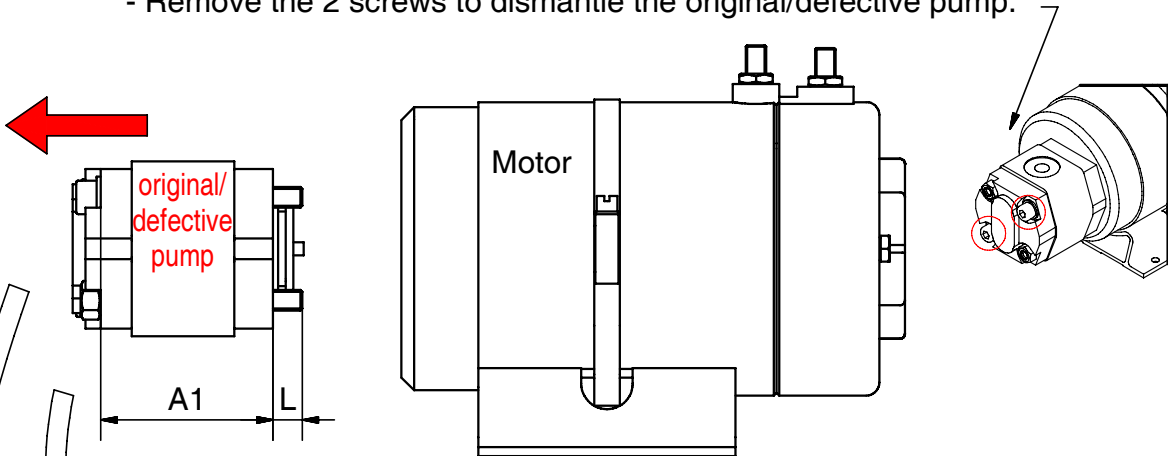

- If new and original/defective pump are not the same type, compare the measurement "A2" of new and the measurement "A1" of original/defective pump.

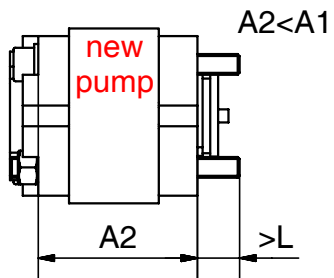

- If "A2" of the new pump is shorter than "A1" of the original/defective pump, additional washers must be placed to get the right screw length.

- ATTENTION: If measurement "L" is too long, the pump will not tighten on the motor. The new pump will be destroyed again!

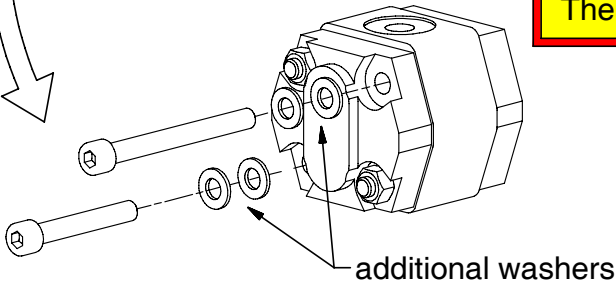

24-30Nm (18-22lb-ft)

- If the screw length is correct, mount the new pump.

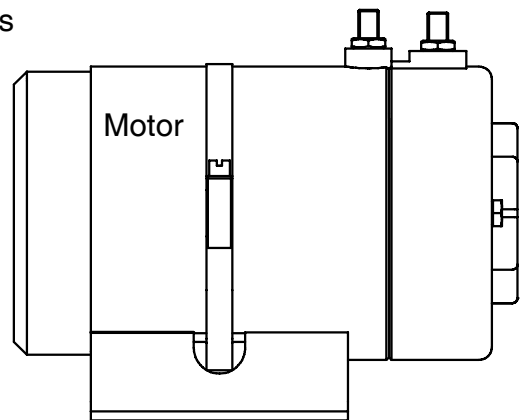
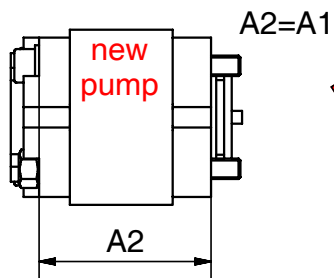

GENERAL OPERATING AND MAINTENANCE INSTRUCTIONS

Hydraulic equipment is usually a part of another piece of equipment, such as a truck. To ensure a long and trouble free operation, always read the manufacturers instructions carefully.

Below is a short list of “Do’s” and “Don’ts”

DO’s:

- When mounting the power pack, make sure it is level to the frame and has easy access for filling the reservoir, doing maintenance, etc.
- The satisfactory functioning, long life, reliability and efficiency of hydraulic equipment is greatly affected by the selection of the most suitable type of hydraulic fluid. We highly recommend hydraulic oil with 22 viscosity.
- In case of very low temperature, less than 0°C (+32°F), use oil with a 10 viscosity.
- Fill the reservoir with a good grade of hydraulic oil. Always use a filtered funnel and clean oil.
- The „AHT“ tailgate loader will permit the use of normal hydraulic oil.

DON'Ts:

- **NEVER** work on the hydraulic system while it is under pressure.
- **NEVER** use tape or pipe dope on the hydraulic fittings. They will seal without any outside help.
- **NEVER** use automatic transmission fluid.
- **VERY IMPORTANT:** If you wish to paint the equipment or weld on it, always mask off all moving parts, flexible connections and nameplates before doing so.

CAUTION: When the “AHT” tailgate loader is steam cleaned, it is very important to be careful around the electrical control box. **DO NOT** point the steam directly at the power pack and control box housing, as the electrical connections are delicate and could be damaged. It is also very important to lubricate the entire unit, after washing, as the grease has been washed away.

SERVICING THE „AHT“ TAILGATE LOADER

Three types of checks need to be made on a regular basis.

- The daily check
- The monthly check
- The annual check

(Report any defects to your supervisor immediately)

*THE DAILY CHECK:

Check all bolts and pins for tightness.

Check for leaks, **under the vehicle**, and inside the hydraulic system.

Check the switches, RAISE, LOWER, EXTENDING and RETRACTING for proper operation.

Check the hydraulic oil level, if any leaks are apparent.

The platform must be completely on the ground and retracted to check the proper oil level (All cylinders must be retracted completely)

*THE MONTHLY CHECK:

Complete the daily check, plus the following:

Pressure wash the entire unit, being careful not to pressure wash inside the power pack and control box.

Check all bolts for looseness and tighten if necessary.

Check all welds for cracks and repair if necessary.

Lubricate all grease fittings.

Replace any worn or broken parts

Check the lowering speed (**Be sure it is safe**)

Check the oil level, and add if necessary (**Do not overfill**)

*THE ANNUAL CHECK:

Complete the daily check

Complete the monthly check, plus the following:

Check all electrical cables for chafing or breaking, repair if necessary

Check all hydraulic lines for leaks, cracks or chafing, repair if necessary

Drain the hydraulic reservoir; clean the filter and the reservoir

Fill reservoir with a good, clean grade of hydraulic oil. (22 viscosity)

Check the lifting capacity (Consult the data plate for correct capacity of this unit)

Check all safety devices (Flags, Roll stops, etc.) for proper operation

Check the wear plates and/or rollers and replace, if necessary

Check all electrical connections for corrosion and tightness. Repair if necessary

Note: Depending on frequency of use, the hydraulic hoses should be changed after approximately three years.

Only **clean** hydraulic oil will allow proper operation of your equipment.

The hydraulic oil **should** be changed once a year. The power pack requests oil of 22cst (usage of 10cst oil during very low temperatures, under minus 10°C).

| Oil | Operating temperature |
|-------|-----------------------|
| HLP10 | -25°C to 50°C |
| HLP15 | -20°C to 60°C |
| HLP22 | -10°C to 80°C |

CLEANING & LUBRICATING THE AHT TAILGATE LOADER

After steam cleaning the „AHT“ tailgate loader, it is **very important** that the tailgate loader is completely dried off and lubricated according to the diagram below.
(30pcs grease fittings)

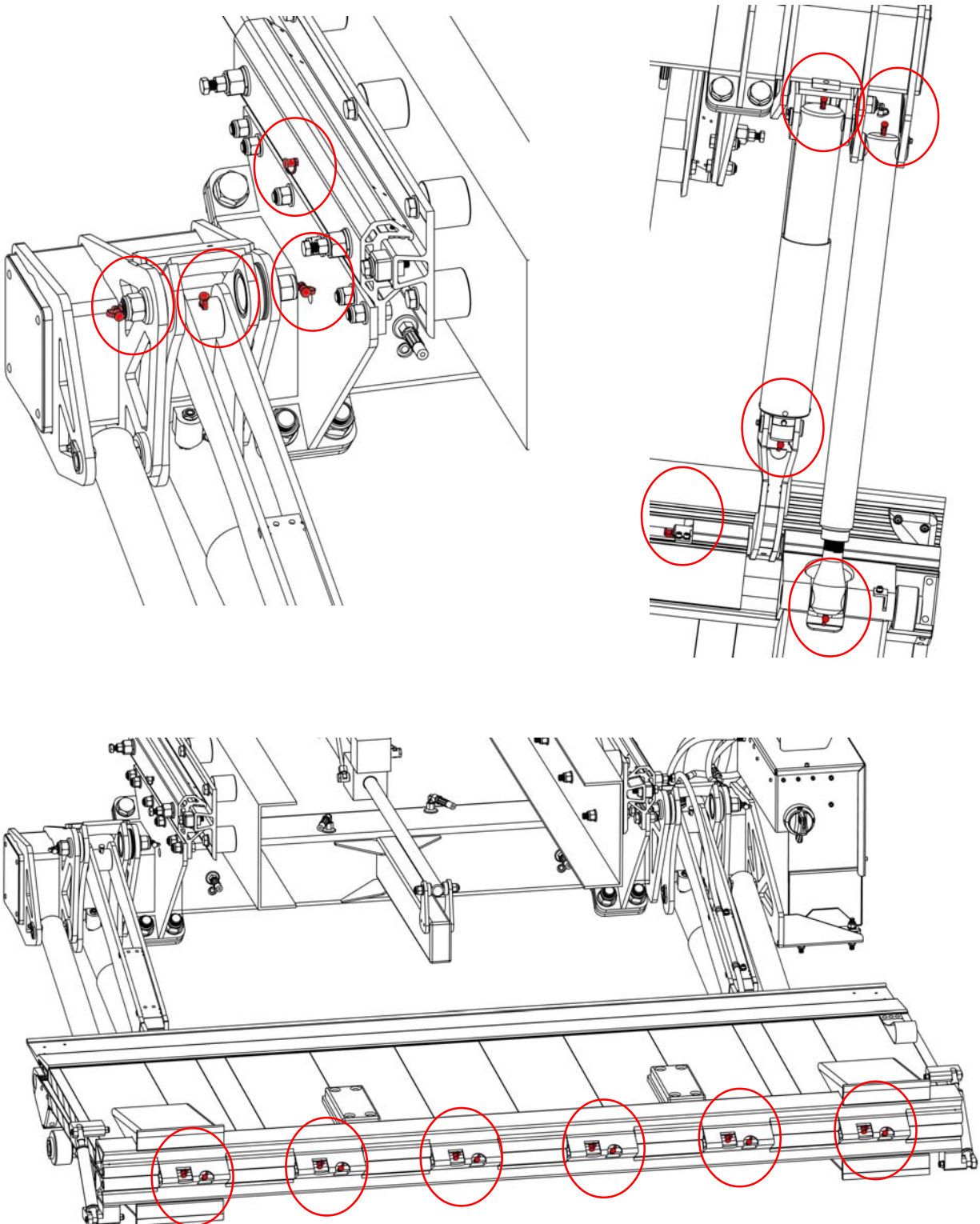

TROUBLE SHOOTING GUIDE

| PROBLEM | CAUSE | CORRECTION |
|--|--|---|
| 01 MOTOR NOT RUNNING | <ul style="list-style-type: none"> a) <i>Main switch is OFF</i> b) <i>Main switch is defective</i> c) <i>Low battery</i> d) <i>Blown fuse in power pack</i> e) <i>No current on buttons</i> f) <i>Ground strap is loose</i> g) <i>Starter solenoid is defective</i> h) <i>Control buttons are defective</i> i) <i>Circuit breaker is defective</i> j) <i>Cub cut off switch or relay defective</i> | <ul style="list-style-type: none"> -Turn switch ON -Repair or replace switch -Charge or replace battery -Replace fuse 12 Volt = 25 Amp, 24 Volt = 16 Amp -Short in cable-repair or replace -Repair or replace ground strap -Repair or replace solenoid -Repair or replace control buttons -Repair or replace circuit breaker -Repair or replace switch of relay |
| 02 MOTOR RUNS SLOWLY | <ul style="list-style-type: none"> a) <i>Low Voltage</i> b) <i>Brushes are dirty or worn out</i> | <ul style="list-style-type: none"> -Check & clean all battery connections -Charge battery -Replace brushes or motor |
| 03 EMPTY PLATFORM WILL NOT RAISE | <ul style="list-style-type: none"> a) <i>Low hydraulic oil</i> b) <i>Suction Filter is plugged</i> c) <i>Relief valve "SV1" set too low</i> | <ul style="list-style-type: none"> -Check oil level. Add new, filtered oil -Check hydraulic system for leaks -In winter months use 10 viscosity -In summer months use 22 viscosity -Clean or Replace Suction Filter -Reset relief valve in Power Pack to 190 Bar (2755 PSI). (A calibrated pressure gauge is necessary to properly adjust relief valve) |
| 04 MOTOR RUNS — PLATFORM WILL NOT RAISE | <ul style="list-style-type: none"> a) <i>No current on lift valve "LV" in power pack</i> b) <i>Lift valve "LV" defective</i> c) <i>Flow control valve "EMRV" is closed</i> | <ul style="list-style-type: none"> -Check for current at lift valve solenoid. Replace if necessary -Clean or replace lift valve -Adjust or replace flow control valve |

TROUBLE SHOOTING GUIDE

| PROBLEM | CAUSE | CORRECTION |
|---|--|---|
| 05 PLATFORM WILL NOT LOWER | <p>a) <i>No current on lift valve "LV" in power pack</i></p> <p>b) <i>Lift valve "LV" defective</i></p> <p>c) <i>Electrical hose burst valve "LCV" defective</i></p> <p>d) <i>Flow control valve "EMRV" is closed</i></p> <p>e) <i>Shuttle valve "WV" is defective</i></p> | <p>-Check for current at lift valve solenoid by energizing the LOWER button</p> <p>-Replace if necessary</p> <p>-Clean or replace lift valve</p> <p>-Clean or replace electrical hose burst valve</p> <p>-Adjust or replace flow control valve</p> <p>-Remove shuttle valve, dismantle it, and blow it out with air. Reassemble and reinstall, if it is still not working, replace shuttle valve</p> <p>-Check the correct torque (35Nm = 26lb-ft) of shuttle valve, otherwise it doesn't work.</p> |
| 06 PLATFORM LOWERS SLOW | <p>a) <i>In winter, it is normal</i></p> <p>b) <i>Flow control valve "EMRV" is adjusted wrong</i></p> <p>c) <i>Piston guide rings are oxidized</i></p> <p>d) <i>Lift arm pins are seized</i></p> | <p>-Use lower viscosity oil (10)</p> <p>-Adjust or replace flow control valve</p> <p>-Replace or clean guide rings</p> <p>-Lubricate all pins</p> |
| 07 PLATFORM RAISES SLOW | <p>a) <i>Lift valve "LV" is leaking inside power pack</i></p> <p>b) <i>Low current to motor</i></p> <p>c) <i>Shuttle valve "WV" is defective</i></p> | <p>-Remove lift valve and blow out with air, in open & closed position</p> <p>-Reinstall valve and check it again, if it is still not working, replace MHW-C-30 valve</p> <p>-Charge battery. Check for poor ground</p> <p>-Remove shuttle valve, dismantle it, and blow it out with air. Reassemble and reinstall, if it is still not working, replace shuttle valve</p> <p>-Check the correct torque (35Nm = 26lb-ft) of shuttle valve, otherwise it doesn't work.</p> |
| 08 PLATFORM RAISES SLOW MOTOR RUNNING NORMALLY | <p>a) <i>Pump defective</i></p> | <p>-Check pressure and repair or replace pump.</p> |

TROUBLE SHOOTING GUIDE

| PROBLEM | CAUSE | CORRECTION |
|--|---|--|
| 09 UP NOT WORKING MOTOR SOUNDS STRANGE | <i>a) Shuttle valve "WV" is defective</i> | <ul style="list-style-type: none"> -Remove shuttle valve, dismantle it, and blow it out with air. Reassemble and reinstall, if it is still not working, replace shuttle valve -Check the correct torque (35Nm = 26lb-ft) of shuttle valve, otherwise it doesn't work |
| 10 LOADED PLATFORM STOPS WHEN LIFTING, BUT THE MOTOR IS STILL RUNNING | <ul style="list-style-type: none"> <i>a) Relief valve "SV1" is set too low</i> <i>b) Load is too heavy or placed in wrong position</i> <i>c) Low Hydraulic Oil</i> | <ul style="list-style-type: none"> -Reset relief valve in Power Pack to 190 Bar (2755 PSI). (A calibrated pressure gauge is necessary to properly adjust relief valve) -Correct load -Check Reservoir and add, if necessary |
| 11 FOOT CONTROL NOT WORKING. CONTROL BOX WORKING | <ul style="list-style-type: none"> <i>a) Safety button micro-switch is defective</i> <i>b) Plug from safety button to cable is defective</i> <i>c) Cable between safety button and power pack is defective</i> <i>d) Plug between safety button and power pack is defective</i> <i>e) Cable from power pack to relays is defective</i> <i>f) Main cable from power pack to both relays is defective</i> | <ul style="list-style-type: none"> -Repair or replace micro-switch -Repair or replace plug -Repair or replace cable -Repair or replace plug -Repair or replace cable -Repair or replace main cable |

TROUBLE SHOOTING GUIDE

| PROBLEM | CAUSE | CORRECTION |
|--|--|---|
| 12 FOOT CONTROL “LOWER” NOT WORKING. “RAISE” WORKING. CONTROL BOX WORKING | <ul style="list-style-type: none"> a) <i>Lower button micro-switch is defective</i> b) <i>Plug from lower button to cable is defective</i> c) <i>Plug between lower button and power pack is defective</i> d) <i>Cable between lower button and power pack is defective</i> e) <i>Cable from power pack to relays is defective</i> f) <i>Main cable from power pack to both relays is defective</i> g) <i>Relays for lower is defective</i> | <ul style="list-style-type: none"> -Repair or replace micro-switch -Repair or replace plug -Repair or replace plug -Repair or replace cable -Repair or replace cable -Repair or replace main cable -Repair or replace relays |
| 13 FOOT CONTROL “RAISE” NOT WORKING. “LOWER” WORKING. CONTROL BOX WORKING | <ul style="list-style-type: none"> a) <i>Raise button micro-switch is defective</i> b) <i>Plug from raise button to cable is defective</i> c) <i>Plug between raise button and power pack is defective</i> d) <i>Cable between raise button and power pack is defective</i> e) <i>Cable from power pack to relays is defective</i> f) <i>Main cable from power pack to both relays is defective</i> g) <i>Relays for raise is defective</i> | <ul style="list-style-type: none"> -Repair or replace micro-switch -Repair or replace plug -Repair or replace plug -Repair or replace cable -Repair or replace cable -Repair or replace main cable -Repair or replace relays |

ELECTRIC WIRING DIAGRAM

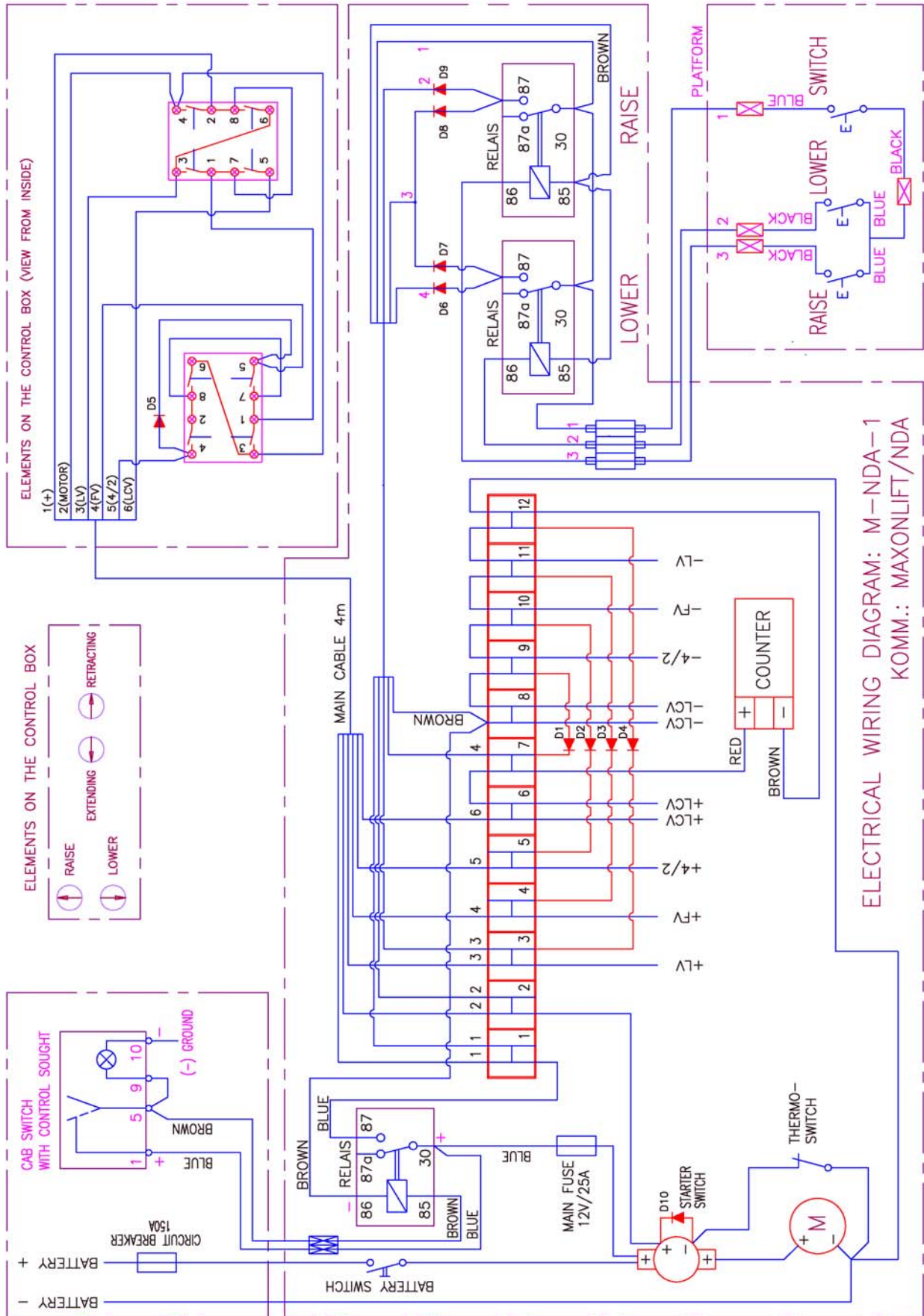

HYDRAULIC SCHEMATIC

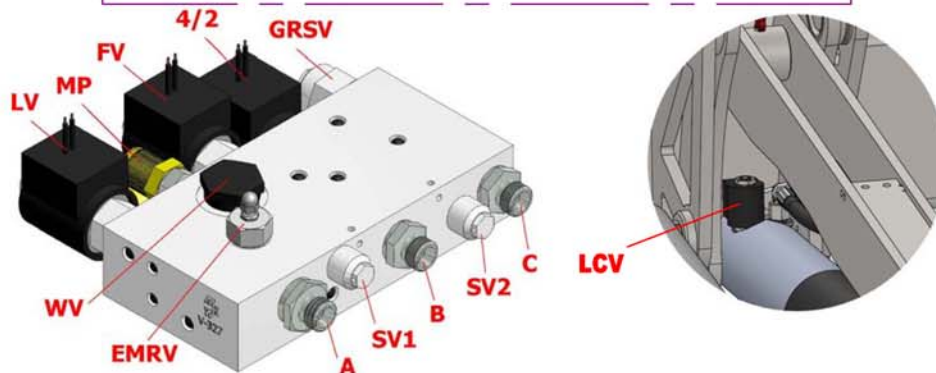
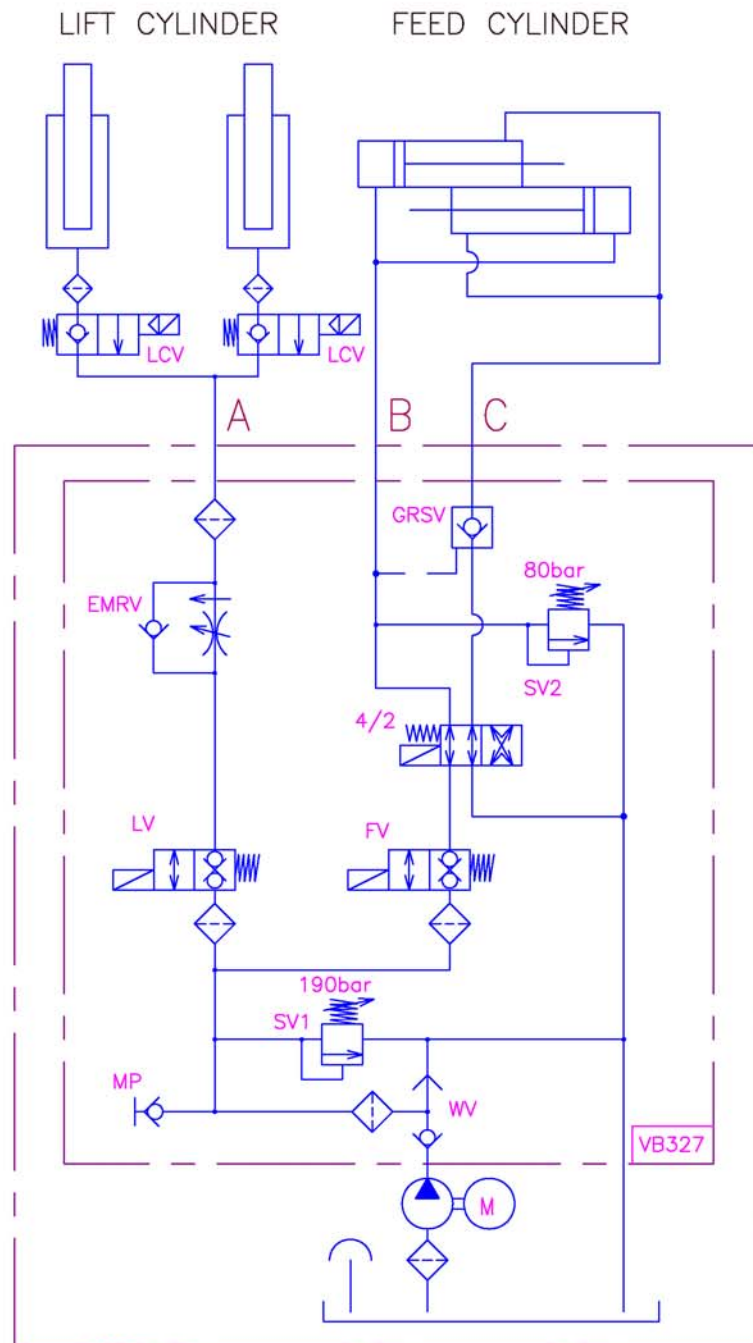

INDEX

| | Page |
|--|---------|
| How to use the „AHT“ tailgate loader | 2 |
| User qualifications to operate the „AHT“ tailgate loader | 2 |
| Safety instructions | 3 |
| Periodic maintenance | 4 |
| Periodic maintenance checklist | 5 |
| Technical description of the „AHT“ tailgate loader | 6 - 12 |
| General operating and maintenance instructions | 13 |
| Servicing the „AHT“ tailgate loader | 14 |
| Cleaning and lubricating the „AHT“ tailgate loader | 15 |
| Trouble shooting guide | 16 - 19 |
| Electrical wiring diagram | 20 |
| Hydraulic schematic | 21 |
| Service records | 22 |