

MAXON®

SPARE PARTS CATALOG

FOR THE
„AHT TAILGATE LOADER“

ULTK-1000ST/AL Frito Lay

for serial number:
10133-10147

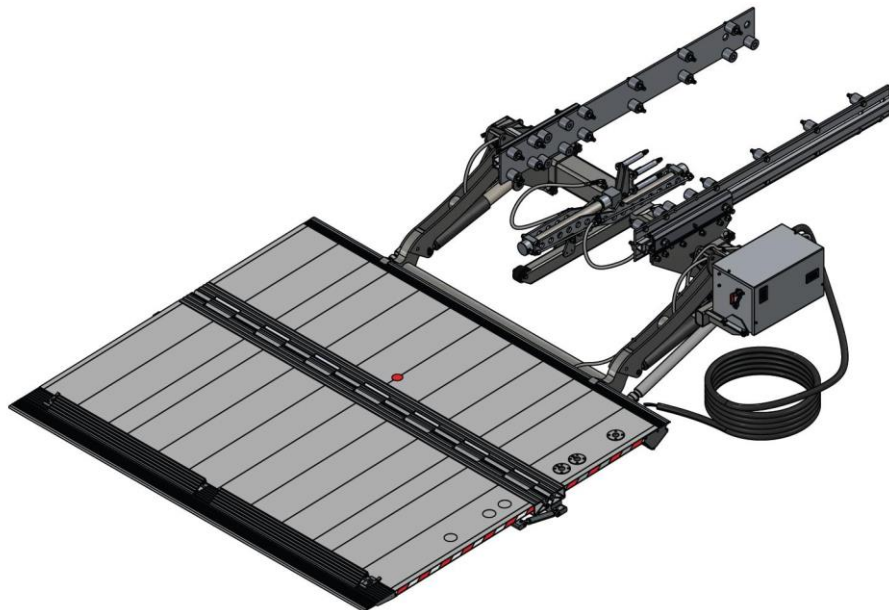

Designed for Maxon by:



Maxon Lift Corp. 11921 Slauson Ave., Santa Fe Springs, CA 90670
800.227.4116 Fax 888.771.7713, www.maxonlift.com

Ladebordwand / *Tailgate loader*

Nr. No.	Stk. Pcs.	Bezeichnung <i>Description</i>	Artikel Nr. <i>Part No.</i>	Zeichnungs Nr. <i>Drawing No.</i>	passend für* <i>suitable for*</i>		
					ULTK-1000 10133-10147	ULTK-1000 10412-10416 10441-10450	ULTK-1500 10473-10492
1	1	Tragkörper Cross beam	TV0JXXRAX1350XX	ULTK-1001ST-1	✓	✗	✗
2	1	Hubwerk Hoisting unit	HL0ISM1350A	LL-1000ST-2M/1350	✓	✗	✗
3	1	Plateau Platform	PU0JVARQLKBX12A	ULTK-1001AL-3	✓	✗	✗
4	1	Flansch links und rechts Mounting brackets left and right	FU0J0S286500XXC	ULTK-1001ST-4K	✓	✓	✗
4.1	1	Führungsschiene links und rechts Rail left and right	FU0JSN1640	ULTK-1000AL-10.2K	✓	✗	✗
5	1	Hydraulikleitung Hydraulic lines	RS0JE1350ULTK	ULTK-1000ST/AL-5K	✓	✗	✗
6	1	Bolzensatz Bolt set	BV0J22	ULTK-1000ST/AL-6K	✓	✗	✗
7	2	Neigeschwinge Tilting bracket	NSSJ02	LTK-1000ST-7K	✓	✗	✗
8	2	Lenker einstellbar Lever arm adjustable	LA0J0100	ULTK-1000ST-7	✓	✓	✗
9	1	Vorschubzylinder Feed cylinder	ZV0Z1125_3525	DWZ-35/25/500+625	✓	✗	✗
9.1	1	Lagerbock Bearing block	VZA0LJ1350	ULTK-1001ST-8K	✓	✗	✗
10	2	Hubzylinder Lift cylinder	ZHA0I42SM	HZ-1000L-M	✓	✗	✗
11	1	Hydraulikaggregat Power pack	0PW1ULTK1A	ULTK1A	✓	✗	✗
12	1	Hauptsicherung Main fuse	0SK10625C		✓	✓	✗
13	1	Stromversorgungskabel Power supply cable	EA111509010		✓	✓	✗
-	1	Aufklebersatz Label set	K11000615		✓	✓	✓

* [ULTK-1000ST/AL](#): Frito Lay
[ULTK-1500ST/AL](#): NDA

Ladebordwand / Tailgate loader

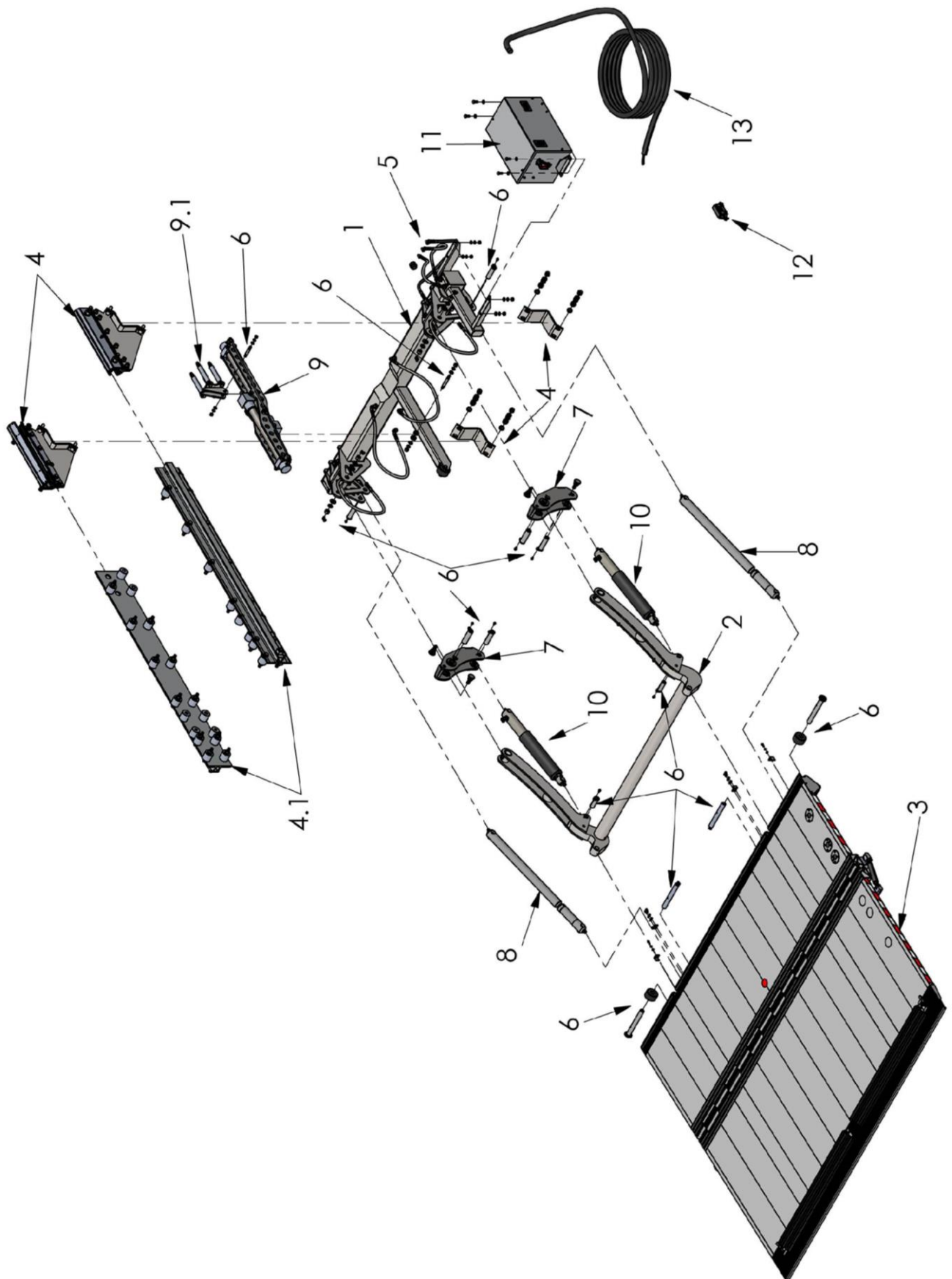

1. Tragkörper / *Cross beam*

Nr. No.	Stk. Pcs.	Bezeichnung Description	Artikel Nr. Part No.	Zeichnungs Nr. Drawing No.	passend für* suitable for*		
					ULTK-1000 10133-10147	ULTK-1000 10412-10416 10441-10450	ULTK-1500 10473-10492
-	1	Tragkörper; komplett Cross beam; assembly	TV0JXXRAX1350XX	ULTK-1001ST-1	✓	✗	✗
1	2	Tragkörperabdeckplatte mit Nieten Cover for cross beam with rivets	TV0J0207	LTK-1001ST-1.7	✓	✓	✗
2	1	Verschleißrolle mit Lagerrolle und Schraube Wear roll with bearing and screw	BS1G0800C	L-500ST-6.7 ULTK-1000ST-6.3	✓	✗	✗
3	1	Schelle RSGU13 mit Schraube Clamp with screw	EA111500187C2		✓	✗	✗
4	4	Sechskantschraube M10x25 mit Mutter Hexagon head screw with nut	S93381100025N		✓	✗	✗

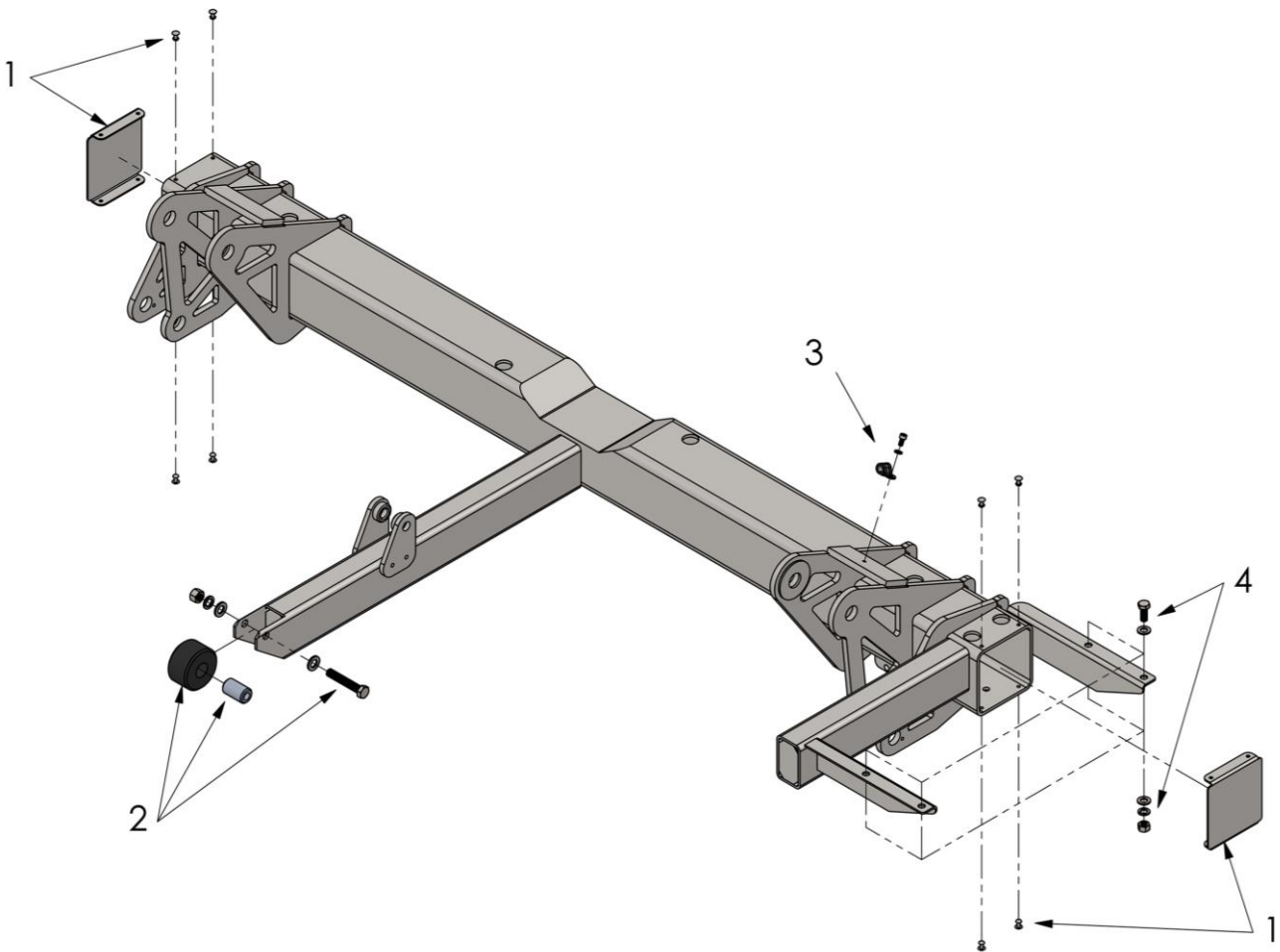

* ULTK-1000ST/AL: Frito Lay
ULTK-1500ST/AL: NDA

2. Hubwerk / *Hoisting unit*

Nr. No.	Stk. Pcs.	Bezeichnung Description	Artikel Nr. Part No.	Zeichnungs Nr. Drawing No.	passend für* suitable for*		
					ULTK-1000 10133-10147	ULTK-1000 10412-10416 10441-10450	ULTK-1500 10473-10492
-	1	Hubwerk; komplett Hoisting unit; assembly	HL0ISM1350A	LL-1000ST-2M/1350	✓	✗	✗
1	4	Buchse DU3020 Bushing	K11000105		✓	✓	✓
2	4	Buchse DU2520 Bushing	K11000106		✓	✗	✗
3	2	Schmiernippel M8x1 mit Staubkappe Grease fitting with cap	S141241000019C		✓	✓	✓
4	2	Staubkappe für Schmiernippel Cap for grease fitting	S141241000099		✓	✓	✓
5	2	Schelle RSGU13 mit Schraube Clamp with screw	EA111500187C12		✓	✗	✓

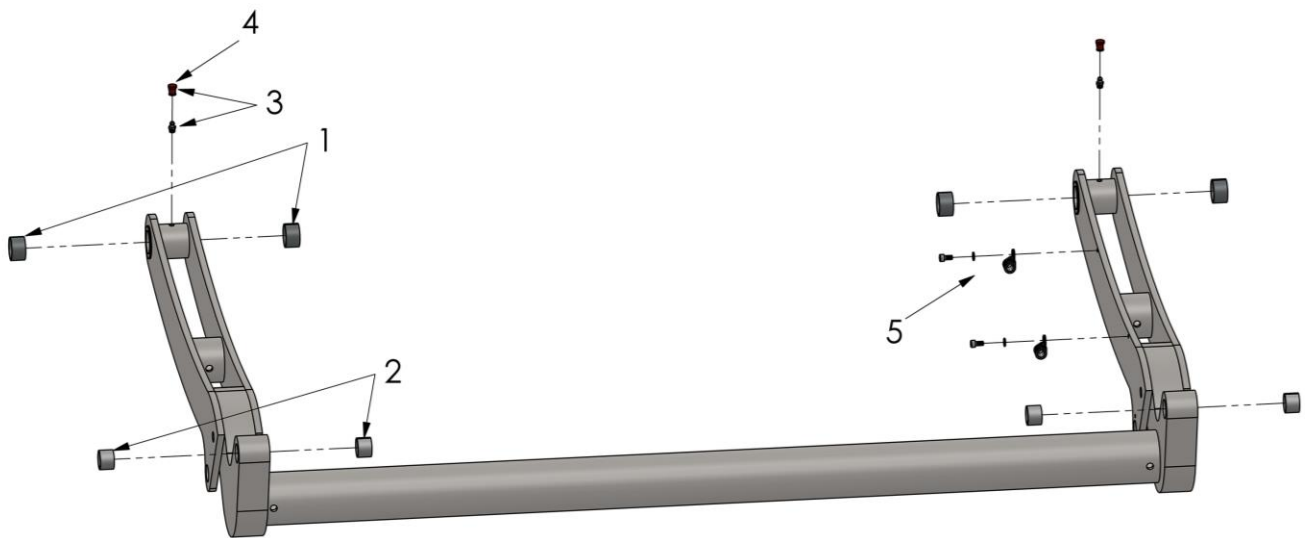

* ULTK-1000ST/AL: Frito Lay
 ULTK-1500ST/AL: NDA

3. Plateau / Platform

Nr. No.	Stk. Pcs.	Bezeichnung Description	Artikel Nr. Part No.	Zeichnungs Nr. Drawing No.	passend für* suitable for*		
					ULTK-1000 10133-10147	ULTK-1000 10412-10416 10441-10450	ULTK-1500 10473-10492
-	1	Plateau; komplett Platform; assembly	PU0JVARQLKBX12A	ULTK-1001AL-3	✓	✗	✗
1	4	Feder für Abrollsicherung Spring for roll stop	K11000103	AHT-ARF-4	✓	✓	✓
2 (R)	1	Verriegelung für Abrollsicherung rechts mit Schraube Lock for roll stop right with screw	PV0R0620	L-500ST-3RS-3.2/Maxon/R L-500ST-3RS-3.1TM	✓	✓	✓
2 (L)	1	Verriegelung für Abrollsicherung links mit Schraube Lock for roll stop left with screw	PV0L0620	L-500ST-3RS-3.2/Maxon/L L-500ST-3RS-3.1TM	✓	✓	✓
3	1	Fußsteuerungsknöpfe, komplett Foot-Control-Buttons; assembly	EA110500025		✓	✓	✓
4	1	Warnstreifen, links & rechts Safety warning stripes, left & right	K11000285C-1510		✓	✓	✗

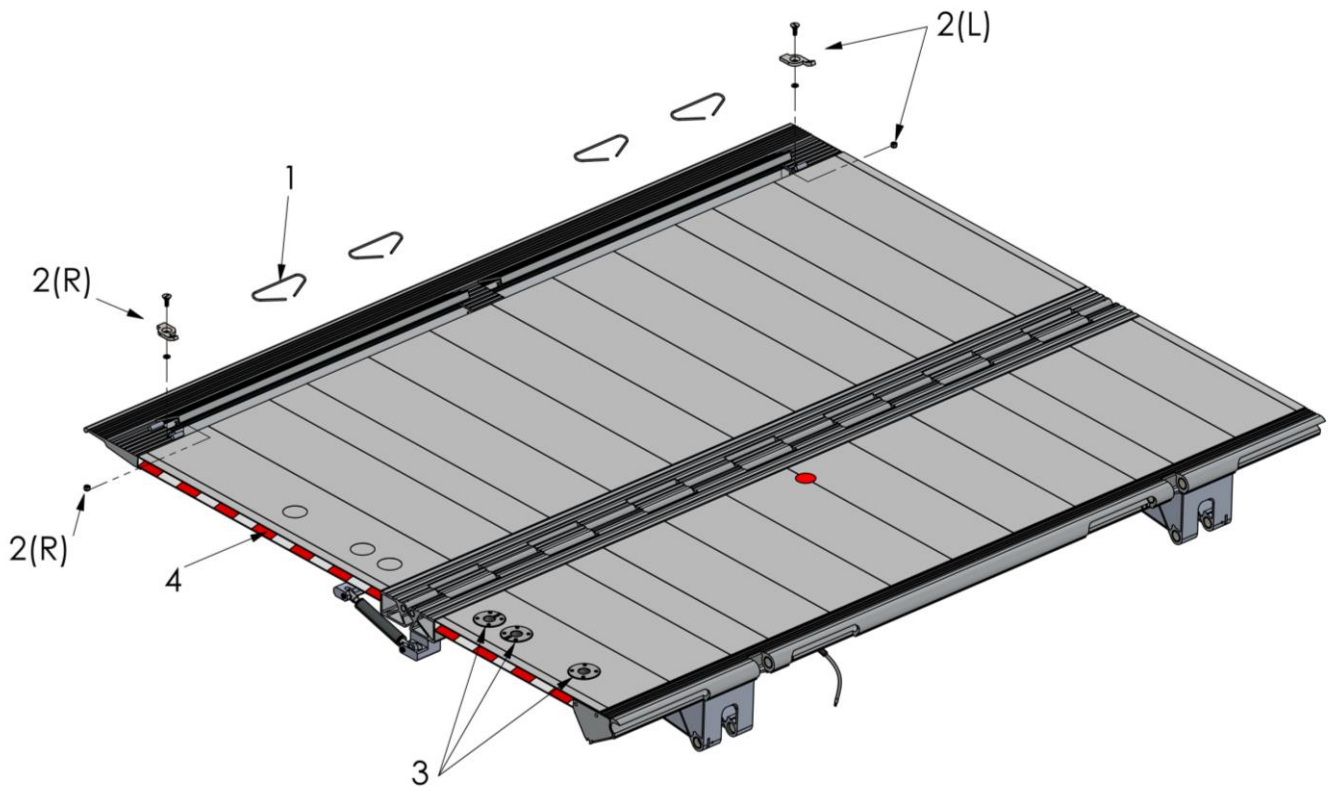

* ULTK-1000ST/AL: Frito Lay
 ULTK-1500ST/AL: NDA

3. Plateau / Platform

Nr. No.	Stk. Pcs.	Bezeichnung Description	Artikel Nr. Part No.	Zeichnungs Nr. Drawing No.	passend für* suitable for*		
					ULTK-1000 10133-10147	ULTK-1000 10412-10416 10441-10450	ULTK-1500 10473-10492
5	2	Gasfeder mit Schrauben Gas spring with screws	K11000567C_90		✓	✗	✗
6	1	Plateaudeckel rechts mit Nieten Cover for platform right with rivets	K12900120C	ABD-K25186A/R	✓	✓	✗
7	1	Plateaudeckel links mit Nieten Cover for platform left with rivets	K12900125C	ABD-K25186A/L	✓	✓	✗
8	1	Aluminium-Buchsensatz Bushing set	PA1J0300M		✓	✓	✗
9	2	Aluminium-Buchse L=13,5mm Bushing	PA1G0302	L-500AL-5.2	✓	✓	✗
10	8	Aluminium-Buchse L=30mm Bushing	TA1G0205	L-500AL-5.1	✓	✓	✗
11	2	Aluminium-Buchse L=45mm Bushing	TA1I0205	LL-1000AL-5.1	✓	✓	✗
12	2	Aluminium-Buchse L=27,5mm Bushing	PA1I0309		✓	✓	✗
13	1	PG-9 Verschraubung für Kabelschutzschlauch Fitting for cable protection hose	EA111500225		✓	✓	✓
14	1	Kabelschutzschlauch PG-9, L=2,3m Cable protection hose	EA111500164_2300		✓	✓	✓
15	1	3-poliges Kabel L=3,5m 3-pole cable	EA111500081_3500		✓	✓	✓

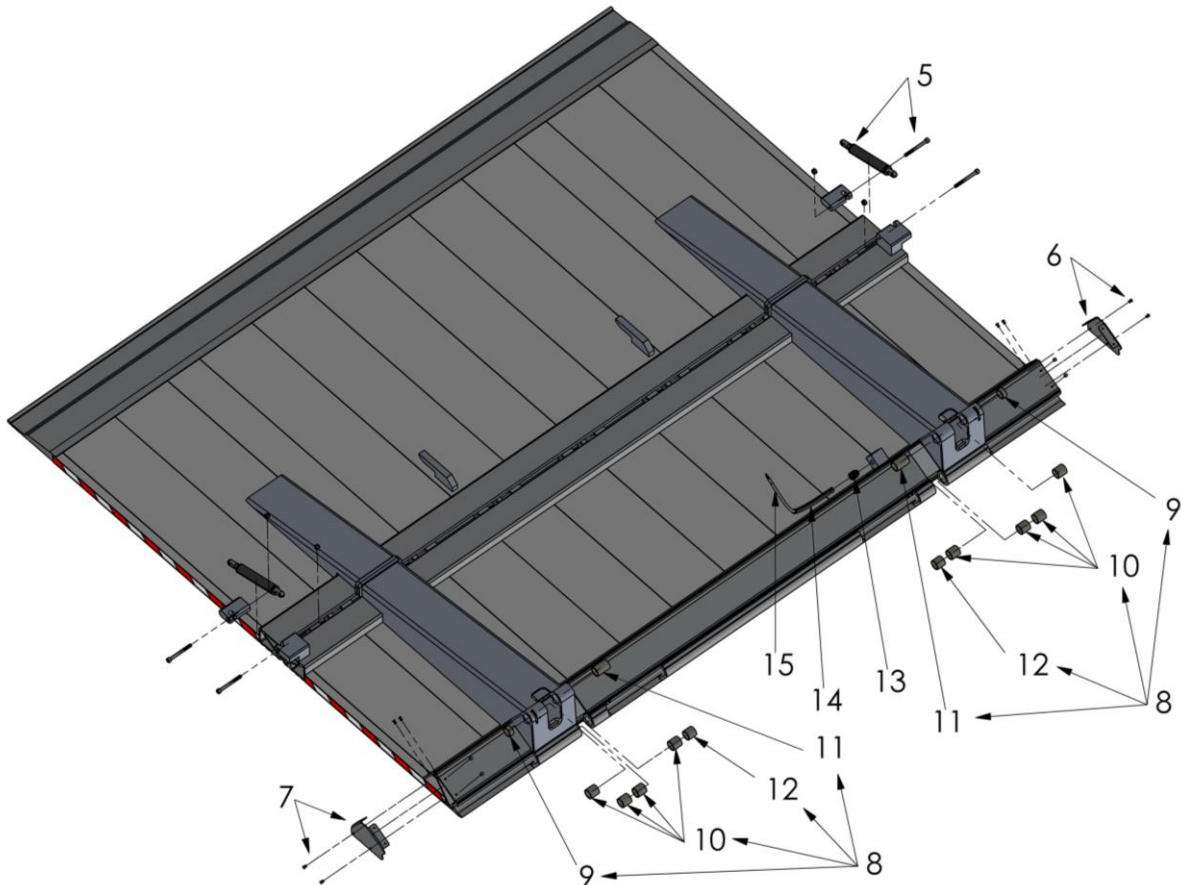

* ULTK-1000ST/AL: Frito Lay
ULTK-1500ST/AL: NDA

3. Plateau / Platform

Nr. No.	Stk. Pcs.	Bezeichnung Description	Artikel Nr. Part No.	Zeichnungs Nr. Drawing No.	passend für* suitable for*		
					ULTK-1000 10133-10147	ULTK-1000 10412-10416 10441-10450	ULTK-1500 10473-10492
16	14	Schmiernippel M8x1 mit Staubkappe Grease fitting with cap	S141241000019C		✓	✓	✓
17	14	Staubkappe für Schmiernippel Cap for grease fitting	S141241000099		✓	✓	✓

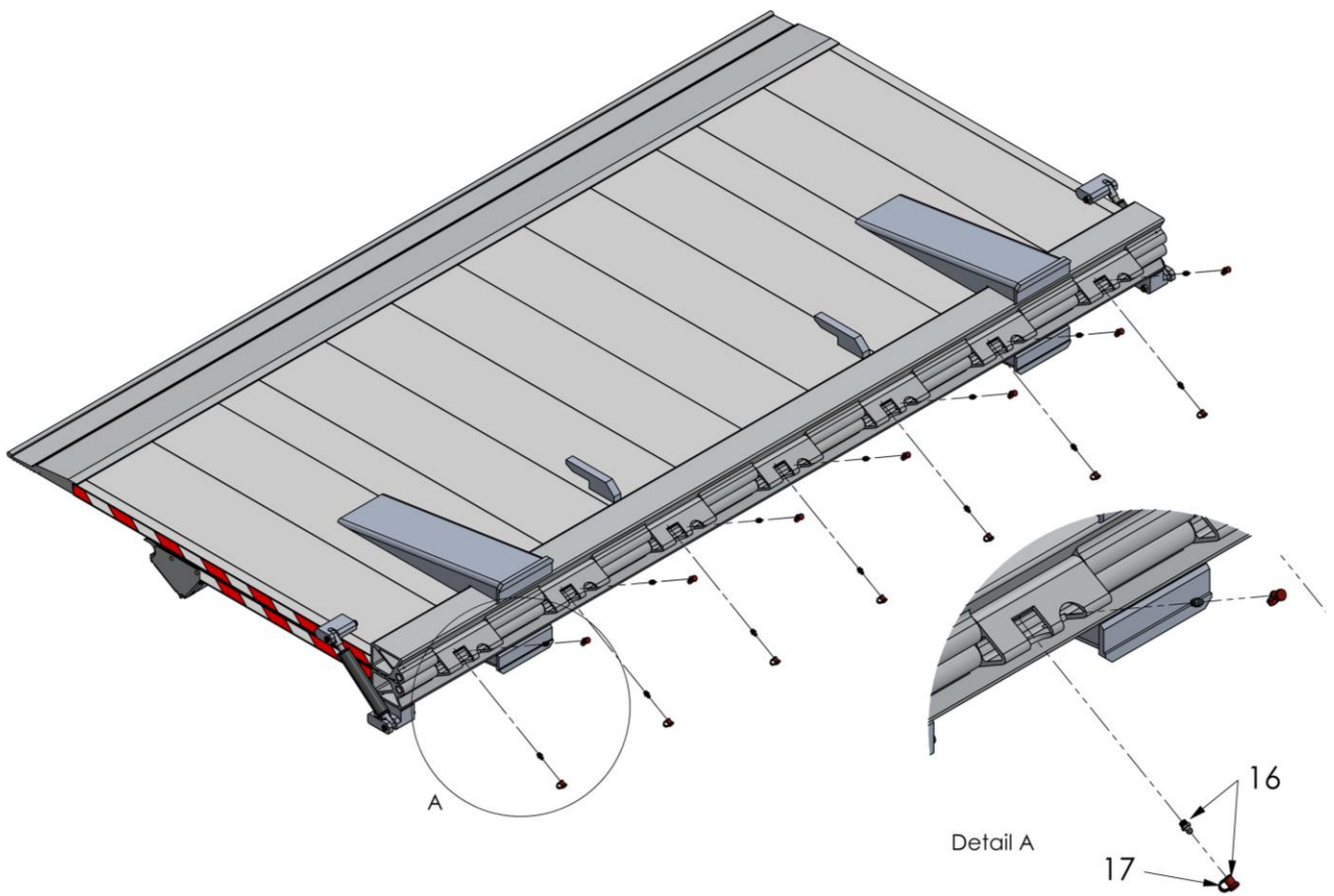

* ULTK-1000ST/AL: Frito Lay
 ULTK-1500ST/AL: NDA

3. Plateau / Platform

3-Knopf-Fußsteuerung / 3-Button-Foot-Control

Nr. No.	Stk. Pcs.	Bezeichnung Description	Artikel Nr. Part No.	Zeichnungs Nr. Drawing No.	passend für* suitable for*		
					ULTK-1000 10133-10147	ULTK-1000 10412-10416 10441-10450	ULTK-1500 10473-10492
-	1	Fußsteuerungsknöpfe; komplett Foot-Control-Buttons; assembly	EA110500025		✓	✓	✓
1	1	Fußsteuerungsknopf Neutral; komplett Foot-Control-Button neutral; assembly	EA110500002	FSK-2000-1	✓	✓	✓
2	1	Fußsteuerungsknopf Senken; komplett Foot-Control-Button lower; assembly	EA110500001	FSK-2000-2	✓	✓	✓
3	1	Fußsteuerungsknopf Heben; komplett Foot-Control-Button raise; assembly	EA110500000	FSK-2000-3	✓	✓	✓
4	1	Fußsteuerungsgehäuse Neutral mit Schrauben Foot-Control-Casing neutral with screws	EA110500014C	FSK-2000-1-1	✓	✓	✓
5	1	Fußsteuerungsgehäuse Senken mit Schrauben Foot-Control-Casing lower with screws	EA110500013C	FSK-2000-2-1	✓	✓	✓
6	1	Fußsteuerungsgehäuse Heben mit Schrauben Foot-Control-Casing raise with screws	EA110500012C	FSK-2000-3-1	✓	✓	✓
7	Gummistoppel Rubber stubble	EA110500010	FSK-2000-4	✓	✓	✓	
8	1	Mikroschalter mit Schrauben und Schrumpfstoßverbinder Micro switch with screws and butt connector	EA110500005C		✓	✓	✓

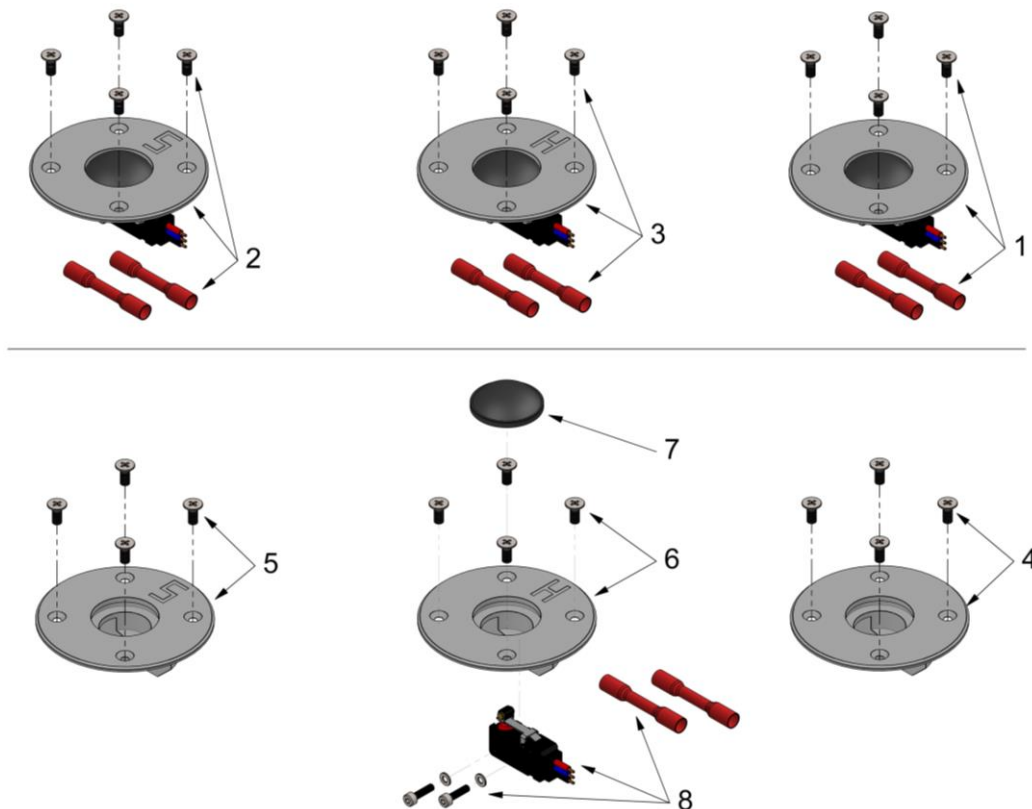

* ULTK-1000ST/AL: Frito Lay
ULTK-1500ST/AL: NDA

4. Flansch / *Mounting bracket*

Nr. No.	Stk. Pcs.	Bezeichnung Description	Artikel Nr. Part No.	Zeichnungs Nr. Drawing No.	passend für* suitable for*		
					ULTK-1000 10133-10147	ULTK-1000 10412-10416 10441-10450	ULTK-1500 10473-10492
-	1	Flansch links und rechts; komplett Mounting brackets left and right; assembly	FU0J0S286500XXC	ULTK-1001ST-4K	✓	✓	✗
1	2	Flansch mit Schrauben Mounting bracket with screws	FU0J0S286500XX	ULTK-1001ST-4	✓	✓	✗
2	2	Führungsschlitten mit Schrauben Guide Block with screws	FU1JFN0500C	ULTK-1000AL-10.1	✓	✓	✗
3	4	Gleitelement rund mit Druckscheibe Slide element circular with pressure disc	K12000092C	UTK-2000ST-SS-4.6.2 ULB-1500AL-4.8	✓	✓	✓
4	4	Gleitelementführung mit Schraube Guide for sliding element with screw	K12000096C	UTK-2000ST-SS-4.6.1	✓	✓	✓
5	8	Gleitelement eckig Slide element rectangular	K12000095	ULB-1500AL-4.9A	✓	✓	✓
6	2	Schmiernippel M8x1 mit Staubkappe Grease fitting with cap	S141241000019C		✓	✓	✓
7	2	Staubkappe für Schmiernippel Cap for grease fitting	S141241000099		✓	✓	✓

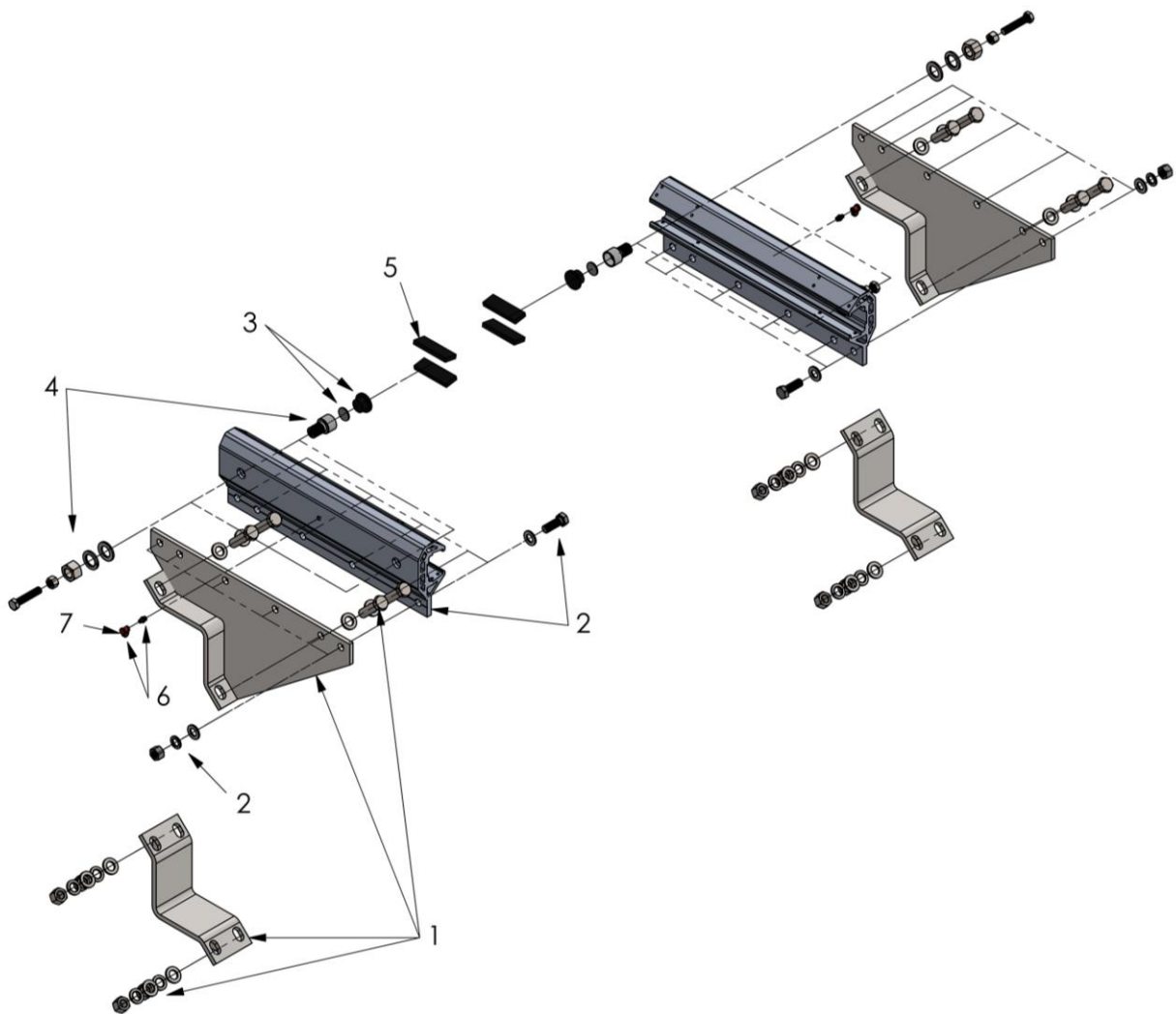

* ULTK-1000ST/AL: Frito Lay
ULTK-1500ST/AL: NDA

4.1. Führungsschiene / Rail

Nr. No.	Stk. Pcs.	Bezeichnung Description	Artikel Nr. Part No.	Zeichnungs Nr. Drawing No.	passend für* suitable for*		
					ULTK-1000 10133-10147	ULTK-1000 10412-10416 10441-10450	ULTK-1500 10473-10492
-	1	Führungsschiene links und rechts; komplett Rail left and right; assembly	FU0JSN1640	ULTK-1000AL-10.2K	✓	✗	✗
1 (R)	1	Führungsschiene rechts Rail right	FU1JSR1640	ULTK-1000AL-10.2R	✓	✗	✗
1 (L)	1	Führungsschiene links Rail left	FU1JSL1640	ULTK-1000AL-10.2L	✓	✗	✗
2	2	Endanschlag mit Schraube End stop with screw	K11002070C	ULTK-751AL-11.2 L-500AL-7.2	✓	✓	✓
3	22	Sechskantschraube M14x100 mit Scheibe und Sicherungsmutter Hexagon head screw with flat washer and self – locking hexagonal nut	S93381140100C		✓	✓	✓
4**	30	Aluhülse L=50mm ø50/15 Spacer	K11007015		✓	✓	✗
5**	4	Aluhülse L=50mm ø50/18 Spacer	K11007018		✓	✗	✗

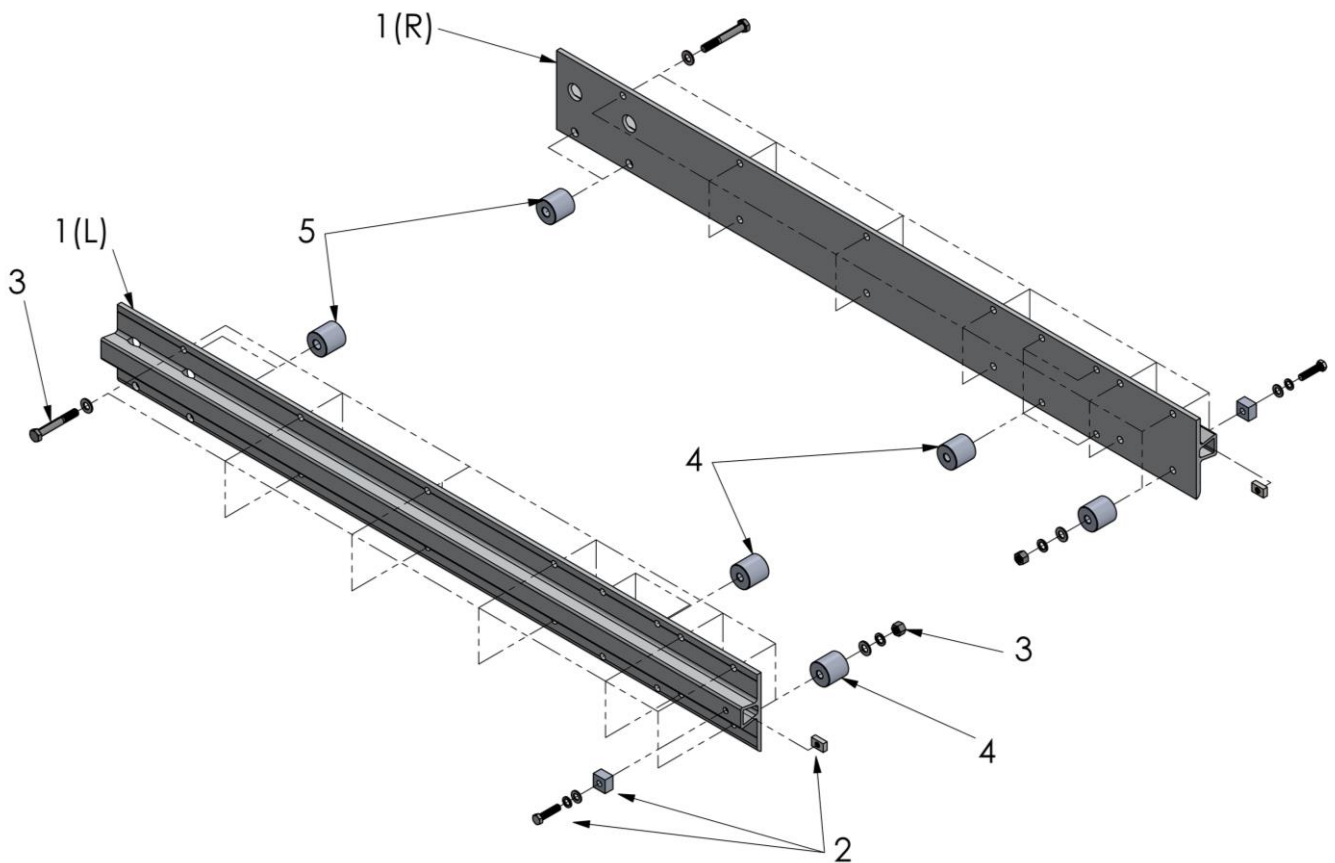

* ULTK-1000ST/AL: Frito Lay
ULTK-1500ST/AL: NDA

** Nicht im Lieferumfang enthalten
Is not part of the scope of delivery

5. Hydraulikleitungen / *Hydraulic lines*

Nr. No.	Stk. Pcs.	Bezeichnung Description	Artikel Nr. Part No.	Zeichnungs Nr. Drawing No.	passend für* suitable for*		
					ULTK-1000 10133-10147	ULTK-1000 10412-10416 10441-10450	ULTK-1500 10473-10492
-	1	Hydraulikleitungen; komplett Hydraulic lines; assembly	RS0JE1350ULTK	ULTK-1000ST/AL-5K	✓	✗	✗
1	1	Hydraulikrohr „Hubzylinder-A“ Hydraulic tube "lift cylinder-A"	RS1MF13500102	ULTK-1000ST/AL-5-HZ	✓	✗	✗
2	1	Hydraulikrohr „Vorschubzyl., ausfahren-B“ Hydraulic tube "feed cyl., extending-B"	RS1MF13500201	ULTK-1000ST/AL-5-VZA	✓	✓	✗
3	1	Hydraulikrohr „Vorschubzyl., einfahren-C“ Hydraulic tube "feed cyl., retracting-C"	RS1MF13500301	ULTK-1000ST/AL-5-VZE	✓	✓	✗
4	4	HD-Schlauch L=750 1x Mutter, Thermoplast High pressure hose L=750 1x nut, thermoplastic	RS1NG60750AT		✓	✓	✓
5	1	HD-Schlauch L=750 2x Mutter, Thermoplast High pressure hose L=750 2x nut, thermoplastic	RS1NG60750BT		✓	✗	✗
6	2	HD-Schlauch L=350 1x Mutter, Thermoplast High pressure hose L=350 1x nut, thermoplastic	RS1NG60350BT		✓	✓	✓
7	3	Winkelstück ohne Mutter 8L Elbow fitting without nut	RV11700032		✓	✓	✓
8	7	Winkelstück mit Mutter 8L Elbow fitting with nut	RV10700002		✓	✓	✓
9	1	T-Stück mit Mutter 8L T-Fitting with nut	OJK10059		✓	✗	✗

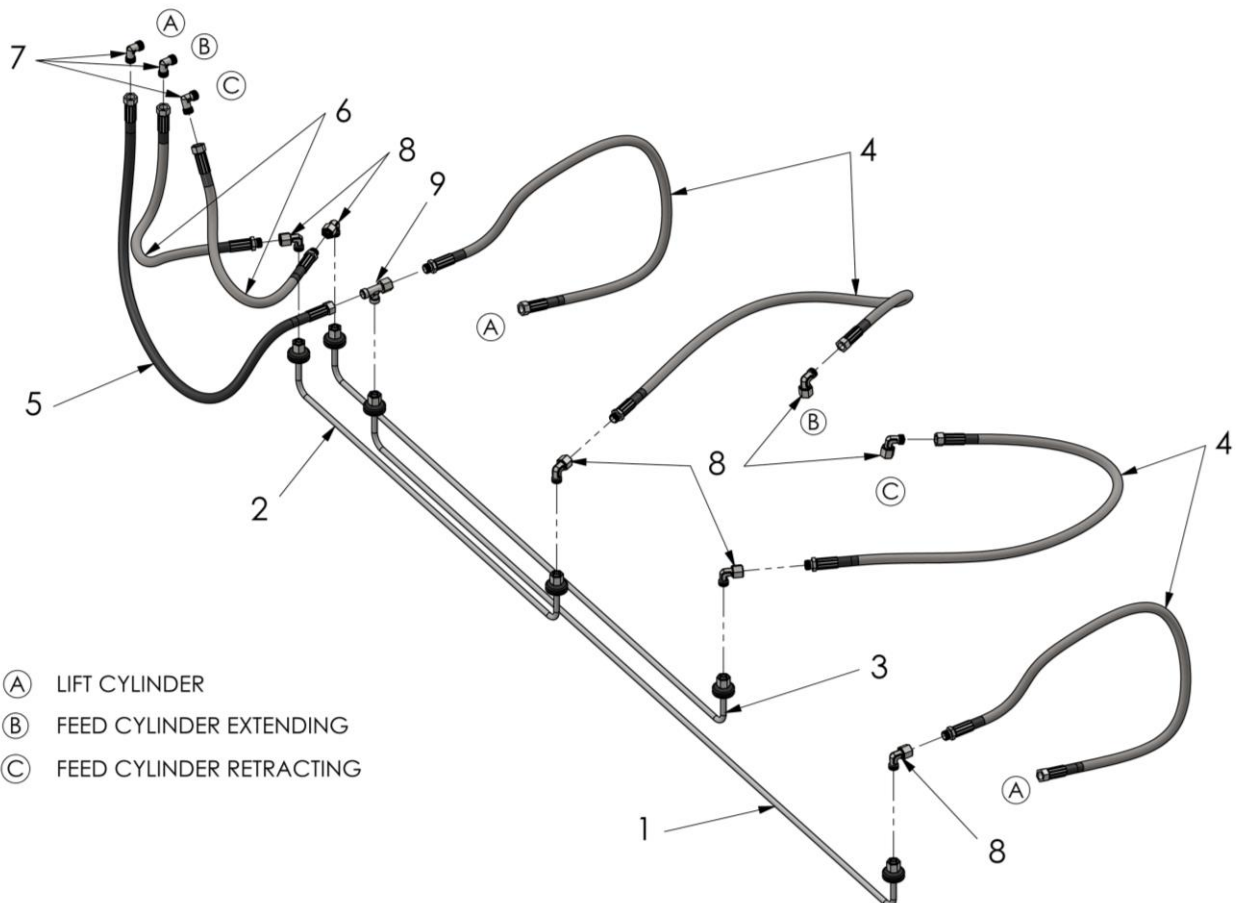

* ULTK-1000ST/AL: Frito Lay
 ULTK-1500ST/AL: NDA

6. Bolzensatz / *Bolt set*

Nr. No.	Stk. Pcs.	Bezeichnung <i>Description</i>	Artikel Nr. <i>Part No.</i>	Zeichnungs Nr. <i>Drawing No.</i>	passend für* <i>suitable for*</i>		
					ULTK-1000 10133-10147	ULTK-1000 10412-10416 10441-10450	ULTK-1500 10473-10492
-	1	Bolzensatz; komplett Bolt set; assembly	BV0J22	ULTK-1000ST/AL-6	✓	✗	✗
1	2	Bolzen (Hubzyl. - Hubwerk) mit Schraube Bolt (Lift cyl. - hoisting unit) with screw	BL1IST0210C	LTK-1000ST-6.1	✓	✓	✗
2	2	Bolzen (Neigeschwinge – Hubzyl.) mit Schraube Bolt (Tilting bracket - lift cyl.) with screw	BL1IST0310C	LTK-1000ST-6.2	✓	✓	✗
3	2	Bolzen (Tragkörper - Lenker) mit Schraube Bolt (Cross beam – lever arm) with screw	BL1IST0410C	LTK-1000ST-6.3	✓	✓	✗
4	2	Bolzen (Plateau - Lenker) mit Bolzensicherungswinkel und Schraube Bolt (Platform – lever arm) with locking angle and screw	BL1IAL0510C	LTK-1000AL-6.4 L-1500AL-6.9	✓	✓	✗
5	2	Bolzensicherungswinkel mit Schraube Locking angle for bolt with screw	BS1AL0303C	L-1500AL-6.9	✓	✓	✓
6	2	Verschleißrolle Wear roll	BS1G0800	L-500ST-6.7	✓	✓	✗
7	2	Bolzen (Hubwerk - Neigeschwinge) mit Schraube Bolt (Hoisting unit – tilting bracket) with screw	BL1IST0610C	LTK-1000ST-6.5	✓	✓	✗
8	2	Bolzen (Plateau - Hubwerk) mit Bolzensicherungswinkel, Schrauben und Schmiernippel Bolt (Platform – hoisting unit) with locking angle, screw and grease fitting	BS1GAL0400C	L-500AL-6.3A L-1500AL-6.10	✓	✓	✗
9	2	Bolzensicherungswinkel mit Schrauben Locking angle for bolt with screws	BS1AL0401C	L-1500AL-6.10	✓	✓	✓
10	2	Schmiernippel M8x1 mit Staubkappe Grease fitting with cap	S141241000019C		✓	✓	✓
11	1	Bolzen (Vorschubzyl. - Lagerbock) mit Muttern Bolt (Feed cyl. – bearing block) with nuts	BV1IST0710C	ULTK-1000ST-6.1	✓	✗	✗
12	1	Bolzen (Vorschubzyl. - Tragkörper) mit Muttern Bolt (Feed cyl. – cross beam) with nuts	BV1IST0810C	ULTK-1000ST-6.2	✓	✓	✗
13	4	Bolzen (Tragkörper - Neigeschwinge) mit Scheibe, Mutter und Schmiernippel Bolt (Cross beam – tilting bracket) with washer, nut and grease fitting	BL1GST0401C	LTK-750ST-8-1A LTK-750ST-8-2A	✓	✓	✗
14	4	Schmiernippel M8x1-90° mit Staubkappe Grease fitting with cap	S141241000011C		✓	✓	✓
15	6	Staubkappe für Schmiernippel Cap for grease fitting	S141241000099		✓	✓	✓
16	8	Sperrzahnschraube RSL M6x12 Rip self-locking screw	S93381060012LS		✓	✓	✓

* ULTK-1000ST/AL: Frito Lay
ULTK-1500ST/AL: NDA

6. Bolzensatz / Bolt set

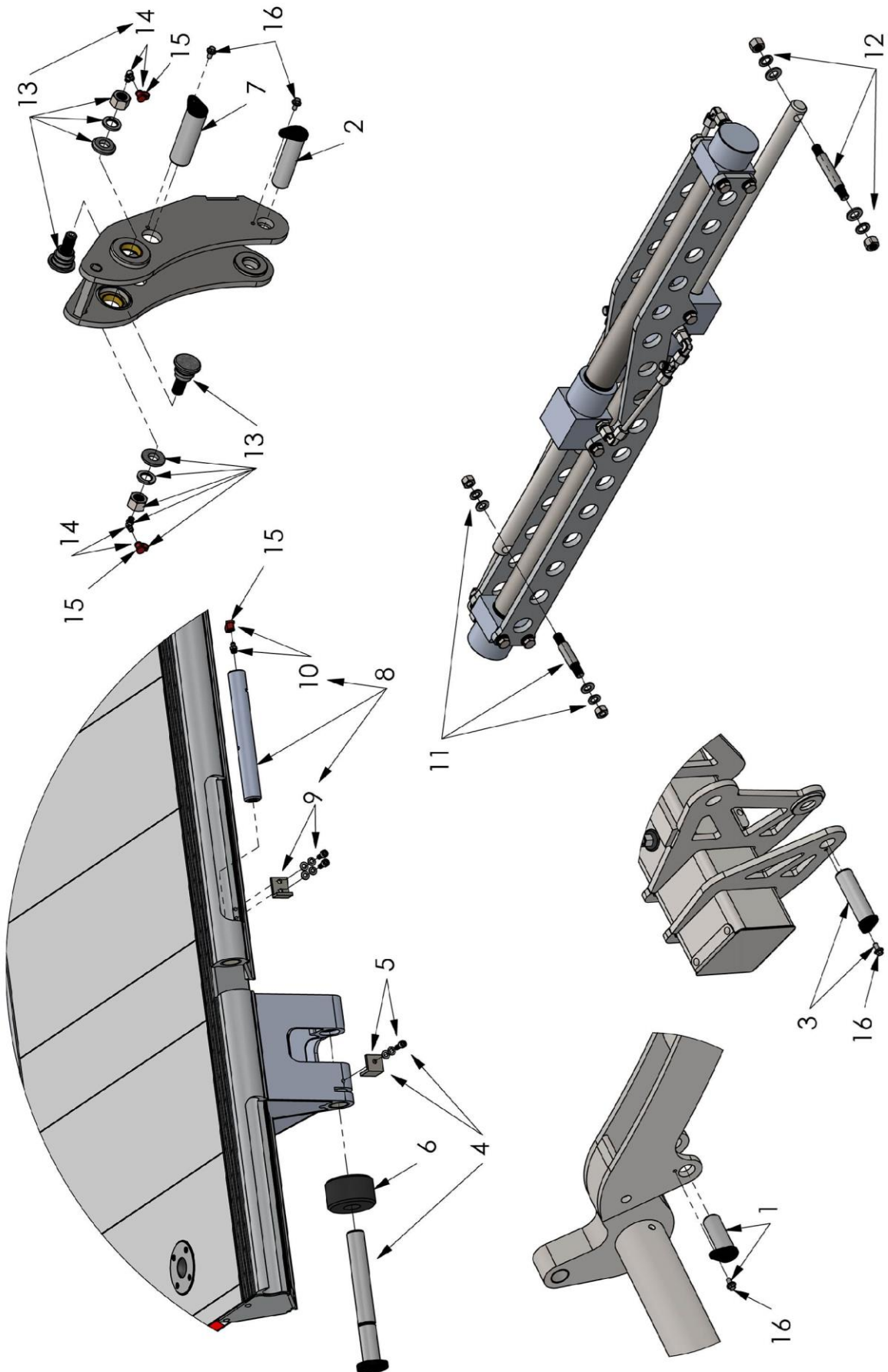

7. Neigeschwinge / *Tilting bracket*

Nr. No.	Stk. Pcs.	Bezeichnung Description	Artikel Nr. Part No.	Zeichnungs Nr. Drawing No.	passend für* suitable for*		
					ULTK-1000 10133-10147	ULTK-1000 10412-10416 10441-10450	ULTK-1500 10473-10492
-	2	Neigeschwinge; komplett <i>Tilting bracket; assembly</i>	NSSJ02	LTK-1000ST-7K	✓	✗	✗
1	2	Bundbuchse FMB 343011.5 <i>Flange bushing</i>	PA1P0309		✓	✓	✗

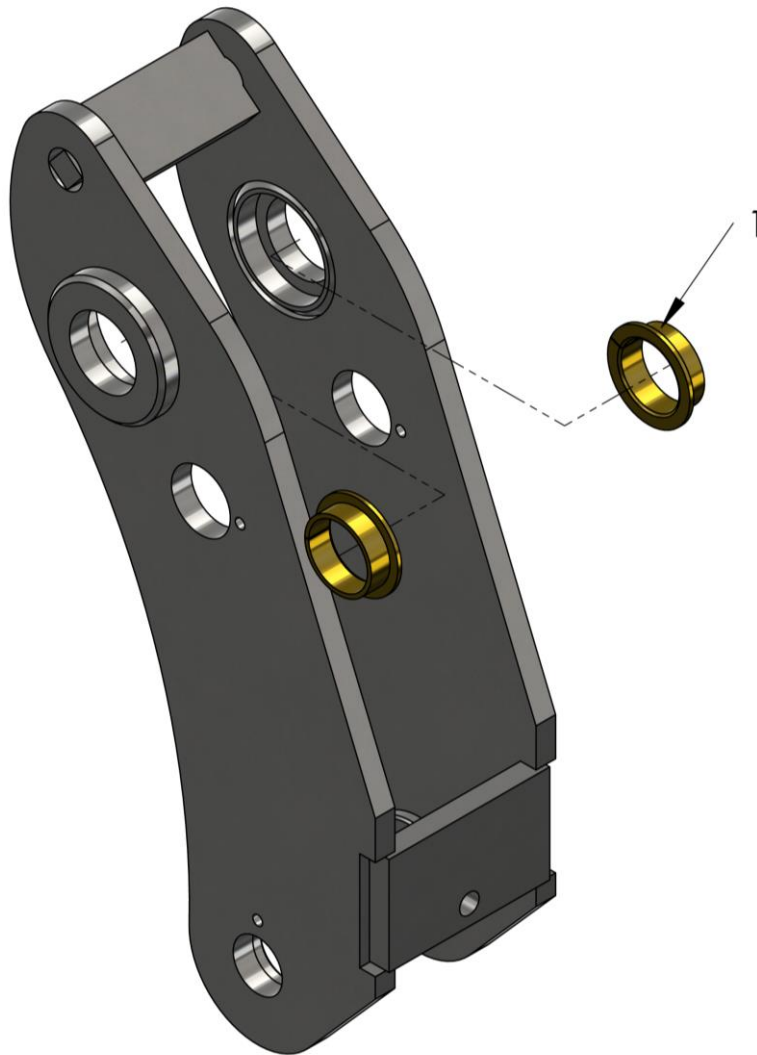

* ULTK-1000ST/AL: Frito Lay
 ULTK-1500ST/AL: NDA

8. Lenker einstellbar / *Lever arm adjustable*

Nr. No.	Stk. Pcs.	Bezeichnung Description	Artikel Nr. Part No.	Zeichnungs Nr. Drawing No.	passend für* suitable for*		
					ULTK-1000 10133-10147	ULTK-1000 10412-10416 10441-10450	ULTK-1500 10473-10492
-	2	Lenker einstellbar; komplett Lever arm adjustable; assembly	LA0J0100	ULTK-1000ST-7	✓	✓	✗
1	1	Lenkerstange mit Buchsen und Schmiernippel Lever arm rod with bushings and grease fitting	LA1J0100	ULTK-1001ST-7M	✓	✓	✗
2	4	Buchse DU2515 Bushing	K11000099		✓	✓	✗
3	1	Schmiernippel M8x1-45° mit Staubkappe Grease fitting with cap	S141241000009C		✓	✓	✓
4	1	Kontermutter Locking nut	ZSA1MM0500	SZ-1500-13M/L	✓	✓	✓
5	1	Druckstange mit Buchsen und Schmiernippel Clevis with bushings and grease fitting	ZSA1GM0445	SZ-752-6M	✓	✓	✗
6	1	Schmiernippel M8x1 mit Staubkappe Grease fitting with cap	S141241000019C		✓	✓	✗
7	2	Staubkappe für Schmiernippel Cap for grease fitting	S141241000099		✓	✓	✓

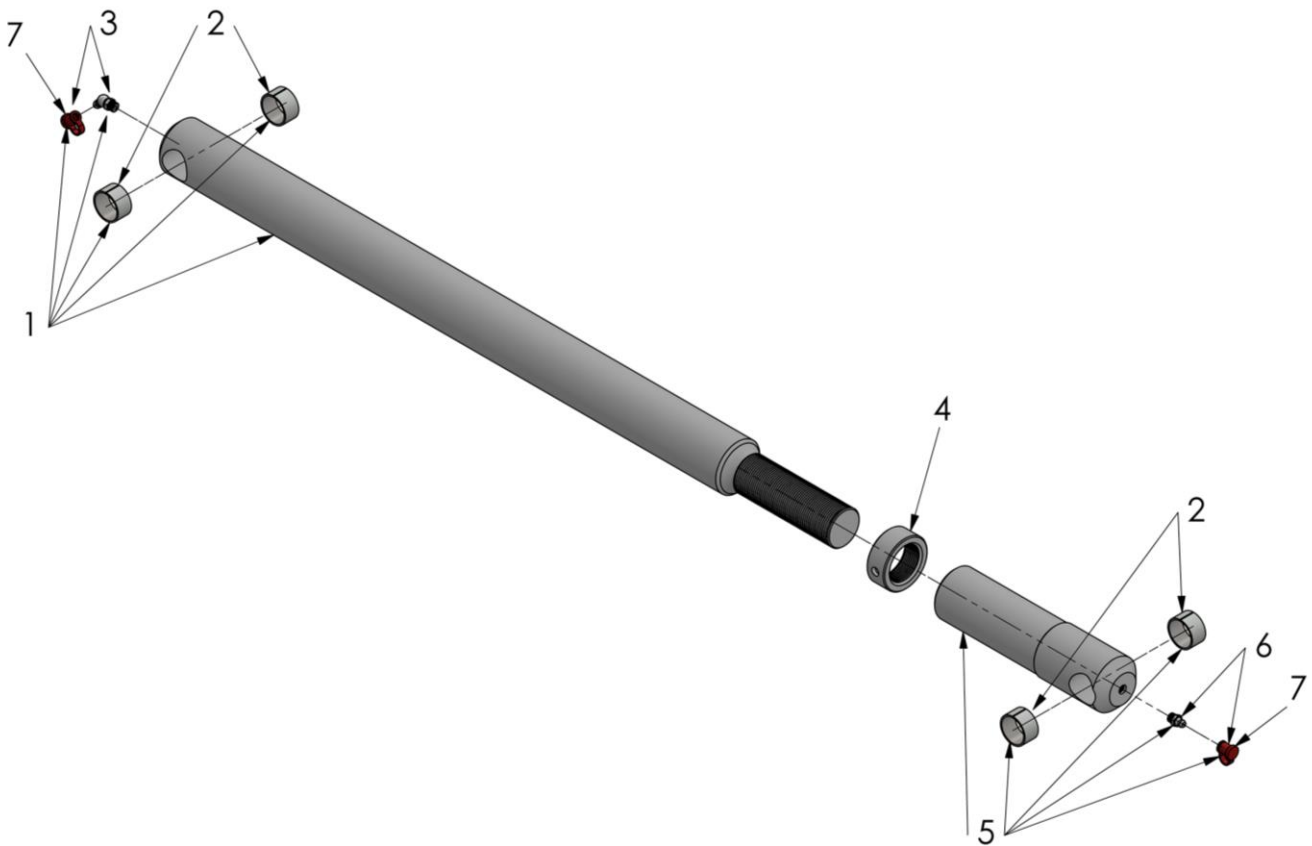

* ULTK-1000ST/AL: Frito Lay
 ULTK-1500ST/AL: NDA

9. Vorschubzylinder / *Feed cylinder*

Nr. No.	Stk. Pcs.	Bezeichnung Description	Artikel Nr. Part No.	Zeichnungs Nr. Drawing No.	passend für* suitable for*		
					ULTK-1000 10133-10147	ULTK-1000 10412-10416 10441-10450	ULTK-1500 10473-10492
-	1	Vorschubzylinder; komplett Feed cylinder; assembly	ZV0Z1125_3525	DWZ-35/25/500+625	✓	✗	✗
-	1	Dichtsatz; komplett Seal kit; assembly	DV0Z3525		✓	✓	✗
1	4	Winkelstück mit Mutter 8L Elbow fitting with nut	RV10700002		✓	✓	✓
2	3	Gerade Einschraubverschraubung G1/4"-8L Straight fitting	0JK10041		✓	✗	✗
3	1	Gerade Einschraubverschraubung G1/4"-8L mit Mutter Straight fitting with nut	0JK10040		✓	✗	✗
4	1	Rohrleitung „Vorschubzyl. einfahren-C“ Hydraulic tube „Feed cyl. retracting-C“	ZV1Z11250530		✓	✗	✗
5	1	Rohrleitung „Vorschubzyl. ausfahren-B“ Hydraulic tube „Feed cyl. extending-B“	ZV1Z11250535		✓	✗	✗

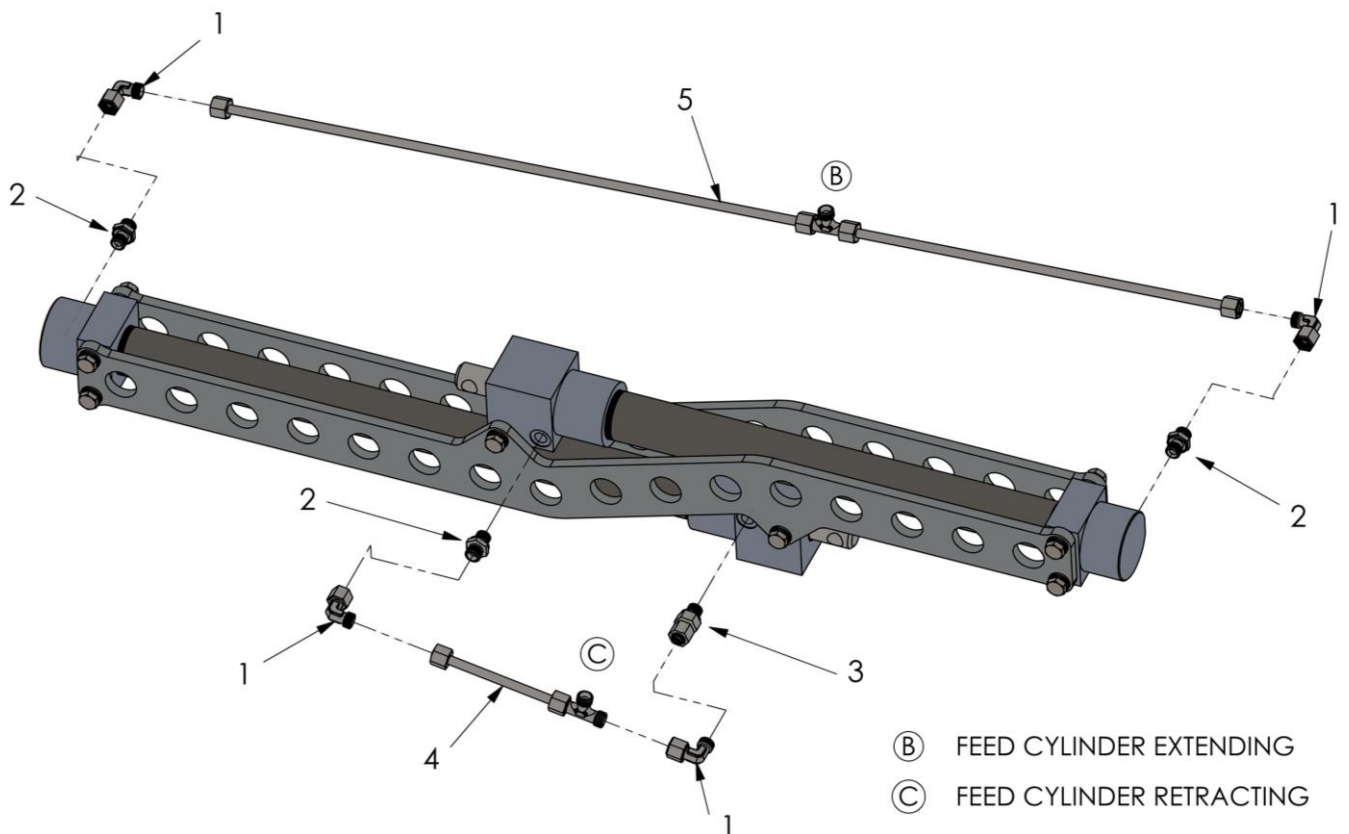

* ULTK-1000ST/AL: Frito Lay
 ULTK-1500ST/AL: NDA

9.1. Lagerbock / *Bearing block*

Nr. No.	Stk. Pcs.	Bezeichnung Description	Artikel Nr. Part No.	Zeichnungs Nr. Drawing No.	passend für* suitable for*		
					ULTK-1000 10133-10147	ULTK-1000 10412-10416 10441-10450	ULTK-1500 10473-10492
-	1	Lagerbock Bearing block	VZA0LJ1350	ULTK-1001ST-8K	✓	✗	✗
1	4	Aluhülsen mit Schrauben Spacer with screws	VZA0LS13500101	ULTK-1000ST-6.4Maxon	✓	✗	✗

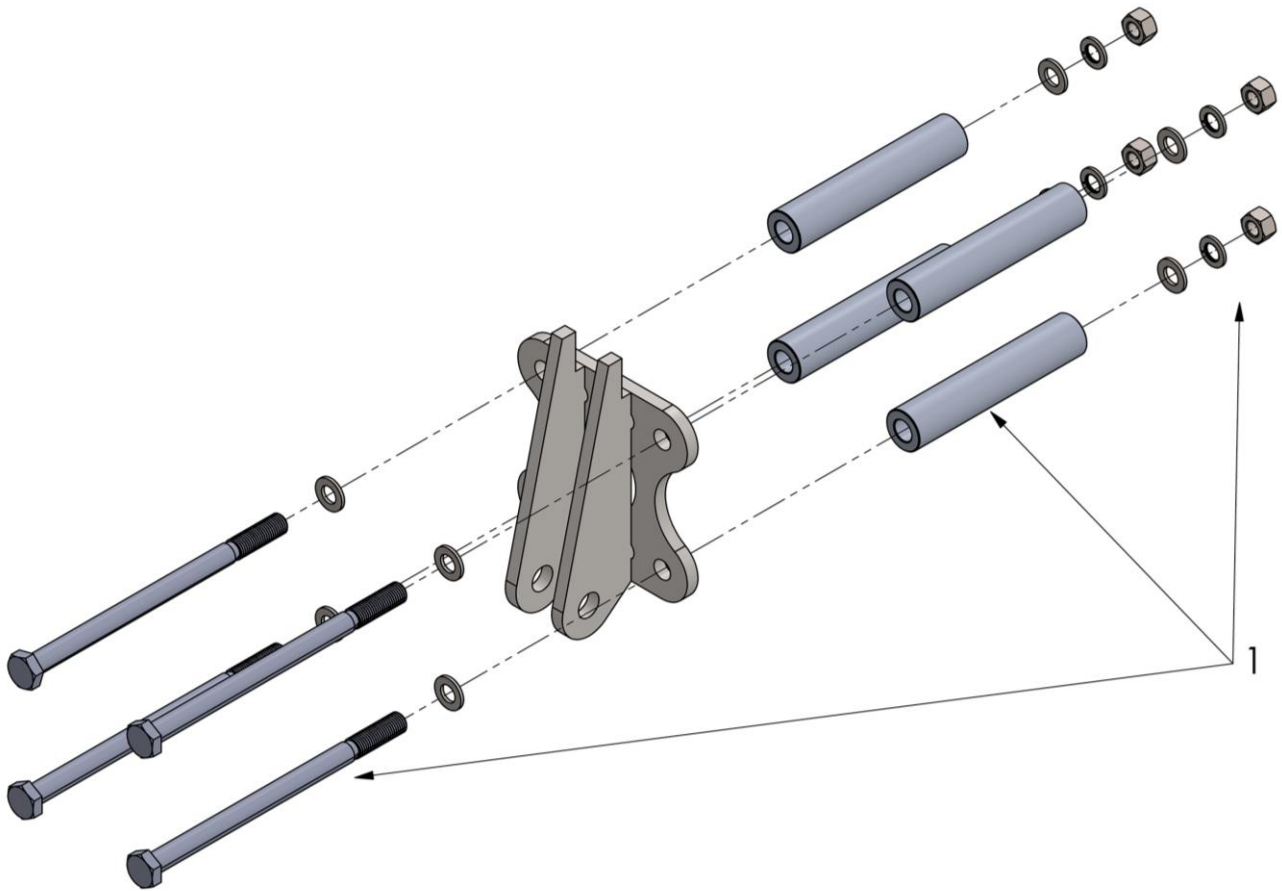

*
 ULTK-1000ST/AL: Frito Lay
 ULTK-1500ST/AL: NDA

10. Hubzylinder / *Lift cylinder*

Nr. No.	Stk. Pcs.	Bezeichnung <i>Description</i>	Artikel Nr. <i>Part No.</i>	Zeichnungs Nr. <i>Drawing No.</i>	passend für* <i>suitable for*</i>		
					ULTK-1000 10133-10147	ULTK-1000 10412-10416 10441-10450	ULTK-1500 10473-10492
-	2	Hubzylinder; komplett Lift cylinder; assembly	ZHA0142SM	HZ-1000L-M	✓	✗	✗
1	1	Zylinderrohr mit Verschraubungen, Buchsen, Dichtungen und Schmiernippel Cylinder tube with fittings, bushings, seals and grease fittings	ZHA110201C	HZ-1000L-1M	✓	✗	✗
2	4	Buchse DU2515 Bushing	K11000099		✓	✓	✗
3	1	Schmiernippel M8x1-45° mit Staubkappe Grease fitting with cap	S141241000009C		✓	✓	✓
4	1	Dichtsatz Seal kit	DH0142		✓	✓	✗
5	1	Mech. Rohrbruchventil G3/8"-8L Mech. Hose burst valve	AT11400088	MHW-GE-R3/8-ED/0,85	✓	✗	✗
6	1	Winkelstück mit Mutter 8L Elbow fitting with nut	RV10700002		✓	✓	✓
7	1	Kolbenschutz mit Schrauben Dust cover with screws	ZHA110400	HZ-1000L-3	✓	✓	✗
8	1	Kolbenstange mit Buchsen und Schmiernippel Piston rod with bushings and grease fitting	ZHA110300	HZ-1000L-2	✓	✓	✗
9	1	Schmiernippel M8x1-90° mit Staubkappe Grease fitting with cap	S141241000011C		✓	✓	✓
10	2	Staubkappe für Schmiernippel Cap for grease fitting	S141241000099		✓	✓	✓

* ULTK-1000ST/AL: Frito Lay
ULTK-1500ST/AL: NDA

10. Hubzylinder / *Lift cylinder*

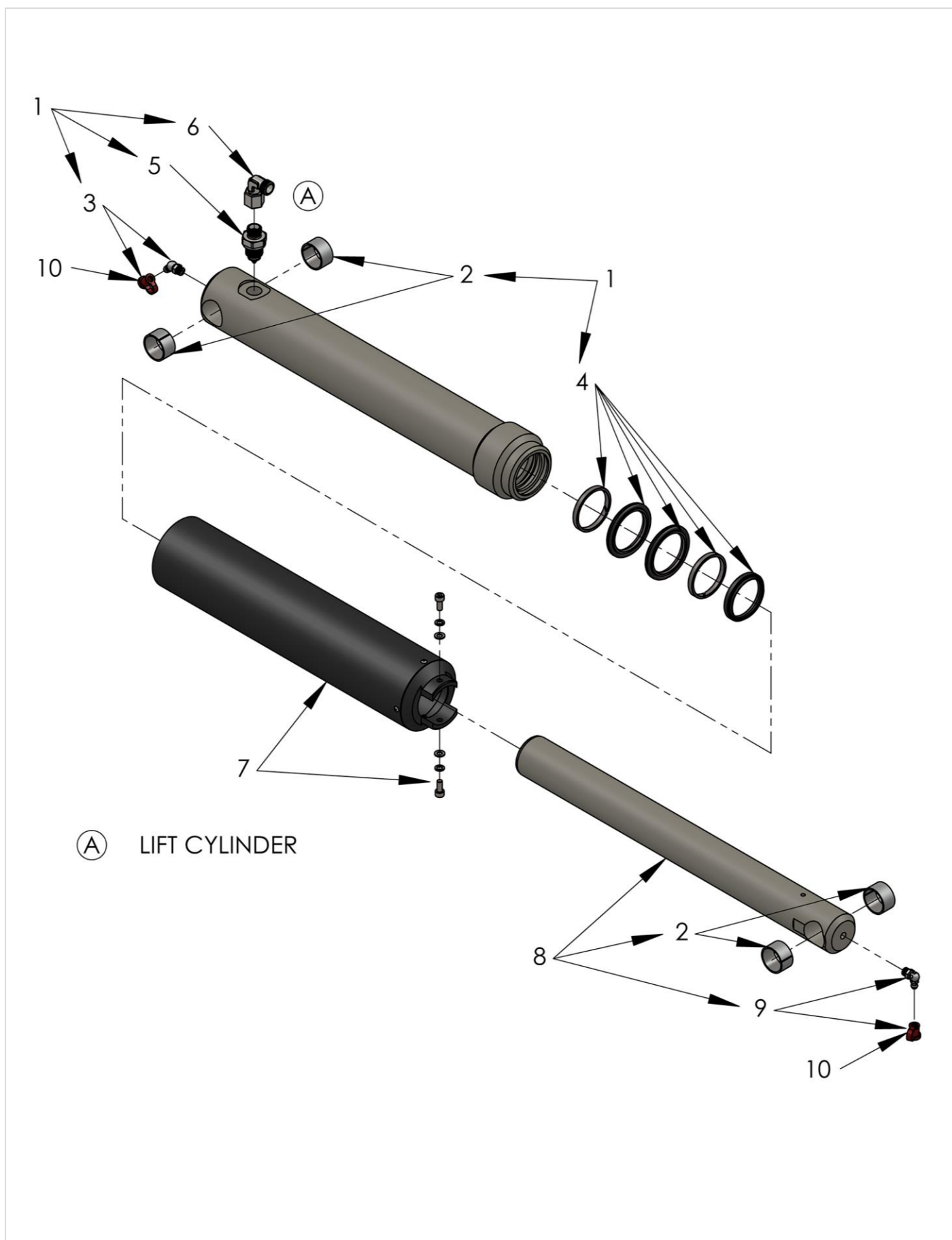

11. Hydraulikaggregat / *Power pack*

Nr. No.	Stk. Pcs.	Bezeichnung <i>Description</i>	Artikel Nr. <i>Part No.</i>	Zeichnungs Nr. <i>Drawing No.</i>	passend für* <i>suitable for*</i>		
					ULTK-1000 10133-10147	ULTK-1000 10412-10416 10441-10450	ULTK-1500 10473-10492
-	1	Hydraulikaggregat 12V; komplett Power pack; assembly	0PW1ULTK1A	ULTK1A	✓	✗	✗
1	1	Aggregatgehäuse Power pack case	0IK30370	ULTK1A-1	✓	✗	✗
2	1	Aggregatgehäusedeckel mit Schrauben; komplett Cover for power pack with screws; assembly	0IK30372C	ULTK-1A-2K	✓	✓	✗
3	1	Motor Pumpeneinheit 12V; komplett Motor-Pump unit; assembly	0PG29020	MHW-2000/1.00/12	✓	✓	✗
4	1	Motorlagerung mit Schlauchschelle ø100- 120/12 und Schrauben Motor base with clamp and screws	0UK10153C	MHW-ML-130	✓	✓	✗
5	1	Ventilblock 12V; komplett Valve block; assembly	0EK20807F12	MHW-VB-327-M/12	✓	✓	✓
6	1	Wechselventil Shuttle valve	0FV21097	MHW-WV-1FO	✓	✓	✓
7	1	Verbindungsstück Adapter for shuttle valve	0RK25238	MHW-VS-U05/ARH	✓	✓	✗
8	3	Hydraulik Rohr L=150mm Hydraulic tube	0XR10004_150		✓	✓	✓
9	1	Ansaugwürfel mit Befestigungsschraube Suction cube with screw	0RK25180C	MHW-AW-U05 MHW-BFS-U05	✓	✓	✗
10	1	Ansaugschlauch ø13/20, L=60mm mit Schlauchschelle Suction tube with clamp	0OK10126_60C		✓	✓	✗
11	1	Retourschlauch ø13/20, L=230mm mit Schlauchschelle Return tube with clamp	0OK10126_230C		✓	✓	✗
12	1	Klemmleiste mit Schrauben Cable connector with screws	0SK11215C		✓	✗	✗
12.1	1	Klemmleiste 10-polig Cable connector	0SK11215		✓	✗	✗
13	1	Magnetstartschalter 12V JK102 mit Schrauben Starter switch with screws	0BK00002C		✓	✓	✓
13.1	1	Magnetstartschalter 12V JK102 Starter switch	0BK00002		✓	✓	✓
14	1	Flachstecksicherung 12V – 25A mit Halter Fuse with holder	0SK11177C		✓	✓	✓
15	1	Öleinfüller für Öltank G1“ Dipstick for oil reservoir	0UK00042K		✓	✓	✓
16	1	Ölablassschraube G1“ Oil drain plug	0UK00049		✓	✓	✓
17	1	Ansaugfilter, austauschbar Suction filter, changeable	0NK10001	MHW-AFS-15.9/1	✓	✓	✓
18	1	PG-9 Verschraubung für Kabelschutzschlauch Fitting for cable protection hose	0SK10658		✓	✓	✓
19	1	PG-21 Verschraubung für Kabelschutzschlauch Fitting for cable protection hose	0SK10726		✓	✓	✓

* ULTK-1000ST/AL: Frito Lay
ULTK-1500ST/AL: NDA

11. Hydraulikaggregat / Power pack

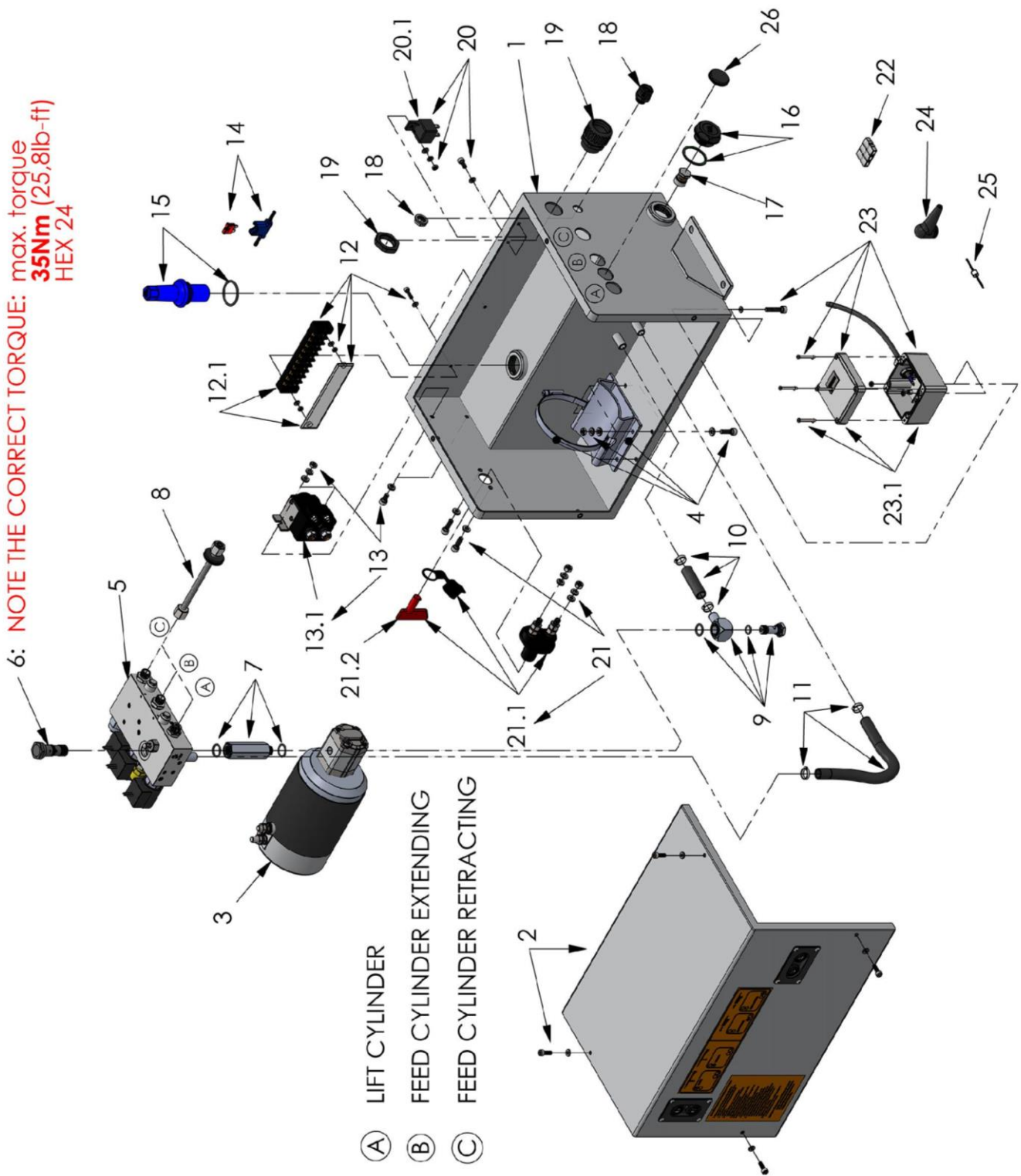

11. Hydraulikaggregat / *Power pack*

Nr. No.	Stk. Pcs.	Bezeichnung <i>Description</i>	Artikel Nr. <i>Part No.</i>	Zeichnungs Nr. <i>Drawing No.</i>	passend für* <i>suitable for*</i>		
					ULTK-1000 10133-10147	ULTK-1000 10412-10416 10441-10450	ULTK-1500 10473-10492
20	2	Würfelrelais 12V mit Schraube Cube-Relay with screw	OSK11180C		✓	✓	✓
20.1	2	Würfelrelais 12V Cube-Relay	OSK11180		✓	✓	✓
21	1	Batterietrennschalter mit Schlüssel und Schrauben Battery main switch with key and screws	OSK11151C		✓	✓	✗
21.1	1	Batterietrennschalter Battery main switch	OSK11151		✓	✓	✗
21.2	1	Schlüssel für Batterietrennschalter Key for battery main switch	OSK11150		✓	✓	✗
22	1	Kabelverbinder 3-polig Cable connector	OSK10215_3		✓	✗	✗
23	1	Zählwerk mit Schrauben Counter box with screws	OSK12001C		✓	✗	✗
23.1	1	Zählwerk Counter box	OSK12001		✓	✗	✗
24	6	Polschutzkappe Protection cap for pole	OUK90000		✓	✓	✓
25**	3	Diode D1-D3 Diode	OSK10863C1-4		✓	✓	✓
	1	Diode D4 Diode	OSK10863C10		✓	✓	✓
	4	Diode D6-D9 Diode	OSK10863C6-9		✓	✓	✓
26	1	Gummitülle ø26/12 Grommet	K11000112		✓	✓	✗

* ULTK-1000ST/AL: Frito Lay
ULTK-1500ST/AL: NDA

** Siehe elektrischen Schaltplan LUM14ZBC
See electrical schematic

11. Hydraulikaggregat / Power pack

6: **NOTE THE CORRECT TORQUE: max. torque 35Nm (25,8lb-ft) HEX 24**

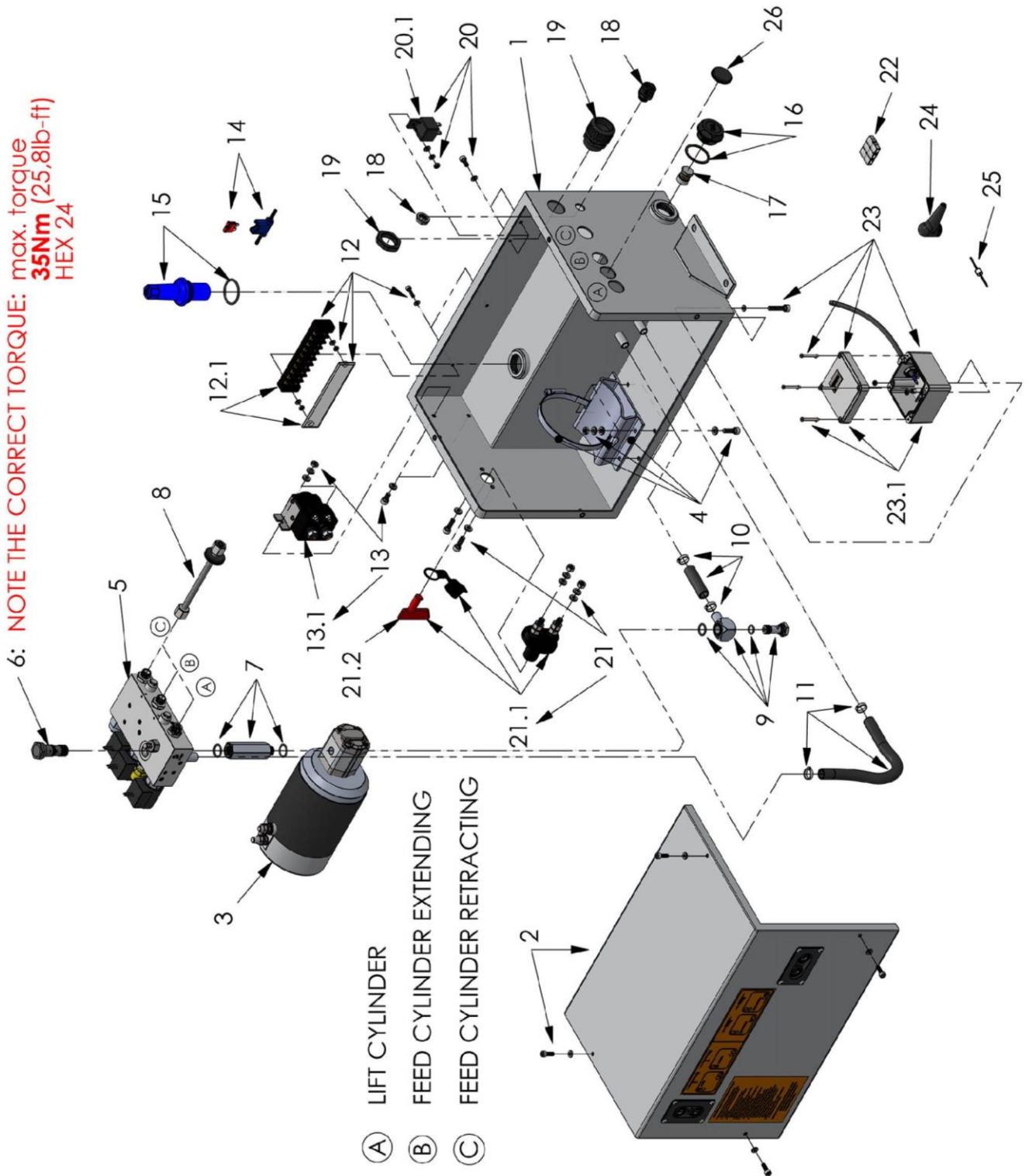

11. Hydraulikaggregat / *Power pack*

Motor Pumpeneinheit / *Motor-Pump unit*

Nr. No.	Stk. Pcs.	Bezeichnung Description	Artikel Nr. Part No.	Zeichnungs Nr. Drawing No.	passend für* suitable for*		
					ULTK-1000 10133-10147	ULTK-1000 10412-10416 10441-10450	ULTK-1500 10473-10492
-	1	Motor Pumpeneinheit 12V; komplett Motor-Pump unit; assembly	0PG29020	MHW-2000/1.00/12	✓	✓	✗
1	1	DC-Motor 12V – 2kW, mit Adapterscheibe und Kupplung DC-Motor, with adapter disc and coupling	0AK01025DCT0		✓	✓	✗
2	1	Pumpe 1.0ccm, mit Schraube und Federring Pump, with screws and spring washer	0CK07054SF	MHW00AR1.0	✓	✓	✗

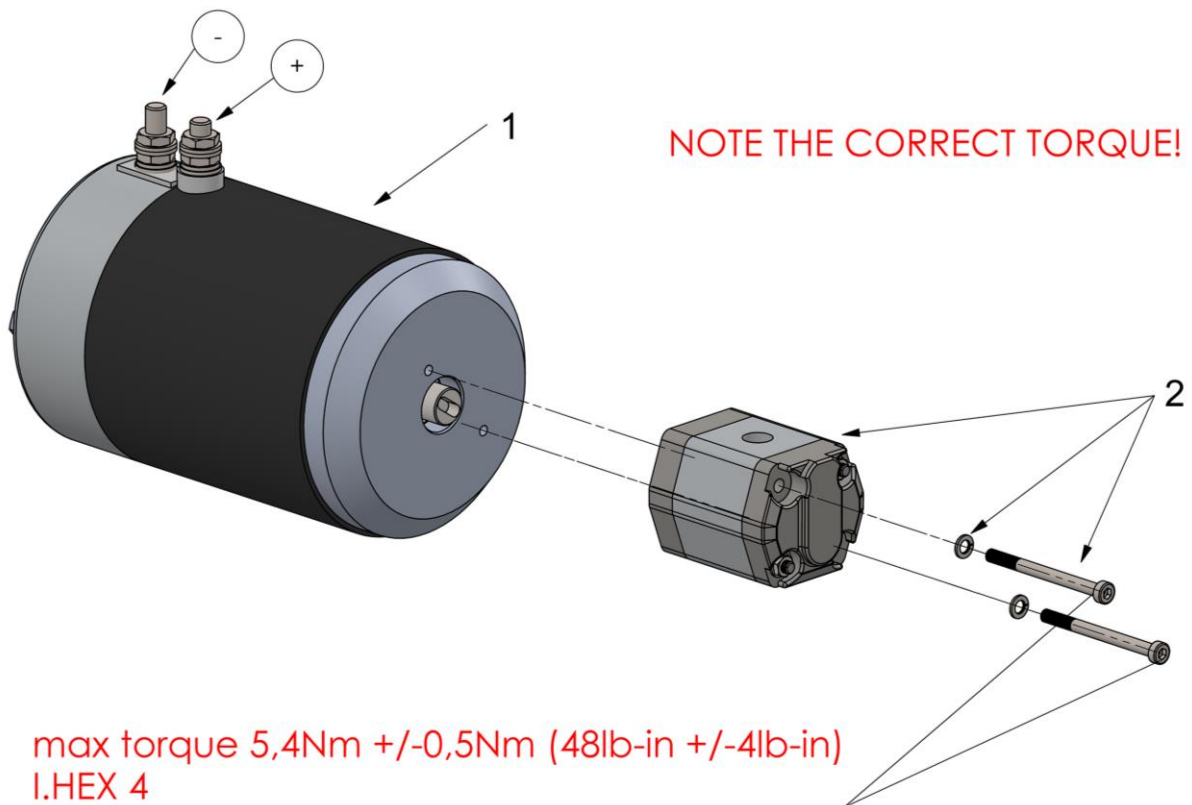

* ULTK-1000ST/AL: Frito Lay
ULTK-1500ST/AL: NDA

11. Hydraulikaggregat / *Power pack*

Anleitung zum Pumpentausch / *How to change the hydraulic pump*

HOW TO CHANGE THE HYDRAULIC PUMP

- Remove the 2 screws to dismantle the original/defective pump.

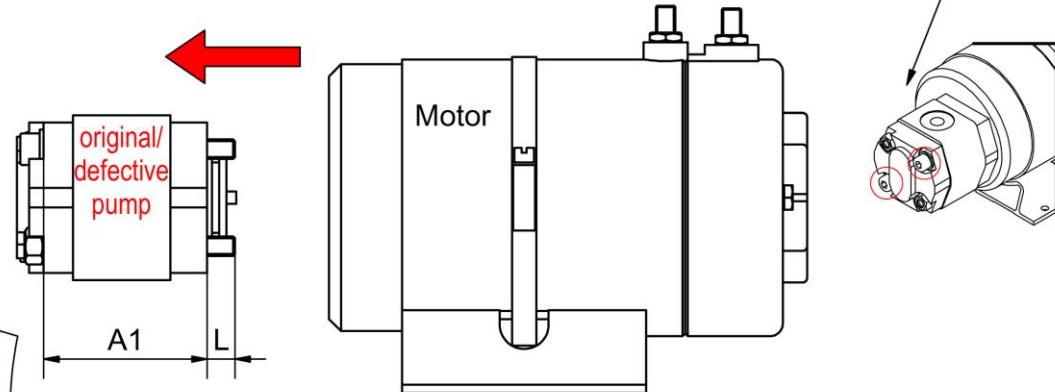

- If new and original/defective pump are not the same type, compare the measurement "A2" of new and the measurement "A1" of original/defective pump.

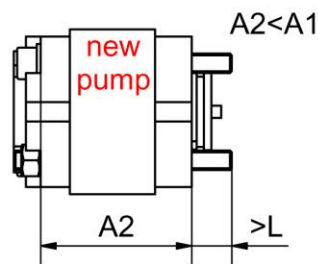

- If "A2" of the new pump is shorter than "A1" of the original/defective pump, additional washers must be placed to get the right screw length.

- ATTENTION: If measurement "L" is too long, the pump will not tighten on the motor. The new pump will be destroyed again!

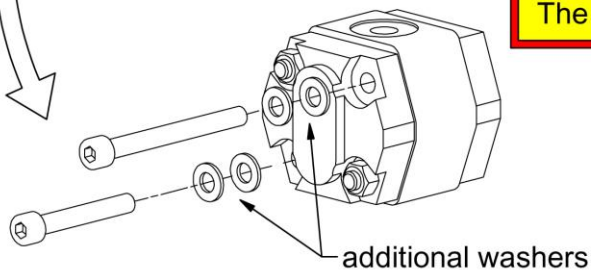

- If the screw length is correct, mount the new pump.

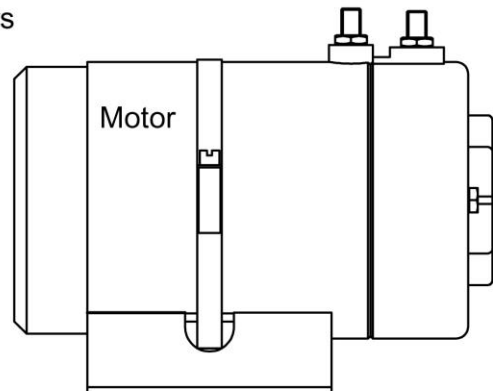
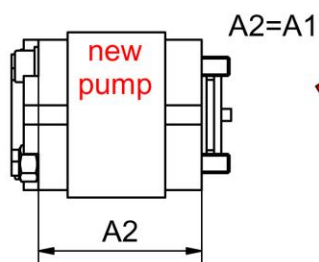

11. Hydraulikaggregat / *Power pack*

Ventilblock VB-327 / *Valve Block VB-327*

Nr. No.	Stk. Pcs.	Bezeichnung Description	Artikel Nr. Part No.	Zeichnungs Nr. Drawing No.	passend für* suitable for*		
					ULTK-1000 10133-10147	ULTK-1000 10412-10416 10441-10450	ULTK-1500 10473-10492
-	1	Ventilblock 12V; komplett Valve block; assembly	0EK20807F12	MHW-VB-327-M/12	✓	✓	✓
1	1	Ventilblock Valve block	0EK20807	MHW-VB-327	✓	✓	✓
2	2	2/2-Wegeventil 2/2-Way valve	0FV20097K	MHW-C-30FP-300	✓	✓	✓
3	1	4/2-Wegeventil 4/2-Way valve	0FV20241	MHW-C-70F	✓	✓	✓
4	3	Magnet mit Litzen 12V Solenoid with dual leads	0GK01001	M33/L300/12VDC/25W	✓	✓	✓
5	1	Gesteuertes Rückschlagventil Pilot check valve	0FV21061	MHW-GRSV-BG1	✓	✓	✓
6	1	Messanschluss Test point plug	AT11400077	MHW-MM8x1	✓	✓	✓
7	2	Sicherheitsventil Relief valve	0FV21067	MHW-SV7x1	✓	✓	✓
8	1	Einstellbare Drosselschraube Adjustable throttle	0FV20910	MHW-EDS-01	✓	✓	✓
9	1	Regelkolben und Feder für Mengenregelventil Piston and spring for flow control valve	0FV21130	MHW-EMRV-5SB	✓	✓	✓
10	1	Gerade Einschraubverschraubung mit Filter Straight fitting with filter	RV10700009	DFV-GE-G3/8"8	✓	✓	✓
11	2	Gerade Einschraubverschraubung G1/4"-8L Straight fitting	0JK10041		✓	✓	✓
12	1	Adapter für Retourleitung Adapter return tube	0RK25056	MHW-RS-M12x1	✓	✓	✓

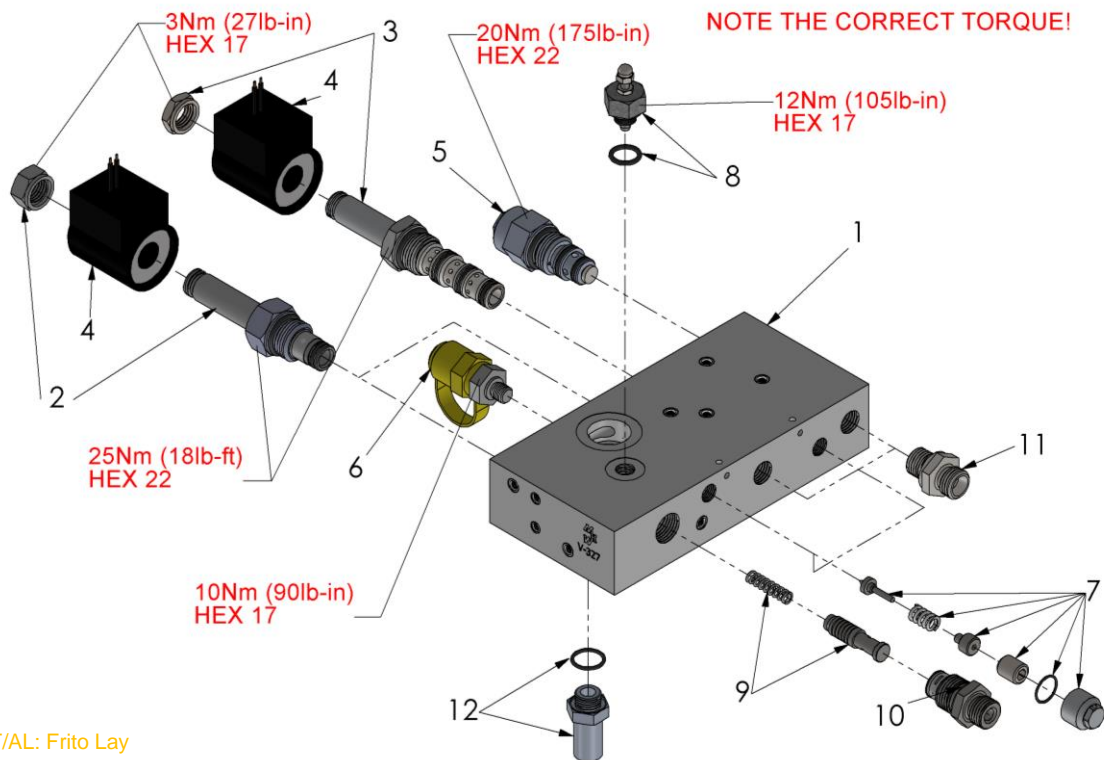

* ULTK-1000ST/AL: Frito Lay
ULTK-1500ST/AL: NDA

11. Hydraulikaggregat / *Power pack*

Aggregatgehäusedeckel / *Cover for power pack*

Nr. No.	Stk. Pcs.	Bezeichnung Description	Artikel Nr. Part No.	Zeichnungs Nr. Drawing No.	passend für* suitable for*		
					ULTK-1000 10133-10147	ULTK-1000 10412-10416 10441-10450	ULTK-1500 10473-10492
-	1	Aggregatgehäusedeckel; komplett Cover for power pack; assembly	0IK30372C	ULTK-1A-2K	✓	✓	✗
1	1	Aggregatgehäusedeckel Cover for power pack	0IK30372	ULTK-1A-2	✓	✓	✗
2	2	Kontaktelement mit Schrauben Contact block with screws	0SK18545C	MHW-2KSM-2002	✓	✓	✓
3	2	Schutzkappe Protective cover, rubber	0SK18542	MHW-2KSM-2002-4	✓	✓	✓
4	4	Schild mit Pfeil Label with arrow	0SK13100	MHW-2KSM-2002-6	✓	✓	✓
5	2	Versenkung für Kontaktblock mit Nieten Recessed cover for push button with rivets	0RK71031KC	MHW-KEK-2D	✓	✓	✓
6**	1	Diode mit Kabel D5 Diode with cable	0SK10863C		✓	✓	✓

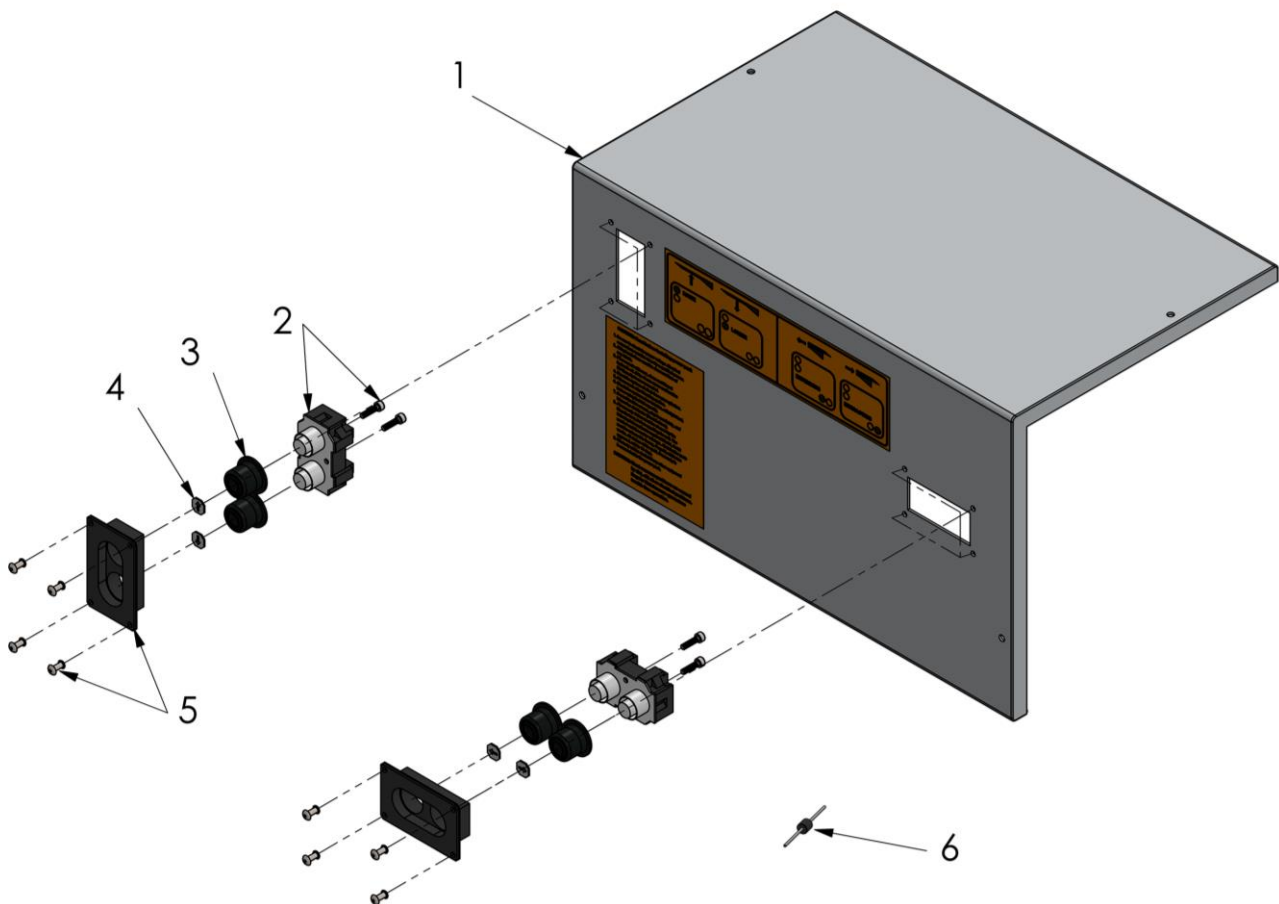

* ULTK-1000ST/AL: Frito Lay
 ULTK-1500ST/AL: NDA

** Siehe elektrischen Schaltplan LUM14ZBC
 See electrical schematic

12. Hauptsicherung / *Main fuse*

Nr. No.	Stk. Pcs.	Bezeichnung Description	Artikel Nr. Part No.	Zeichnungs Nr. Drawing No.	passend für* suitable for*		
					ULTK-1000 10133-10147	ULTK-1000 10412-10416 10441-10450	ULTK-1500 10473-10492
-	1	Hauptsicher 12V – 125A; komplett Main fuse; assembly	OSK10625C		✓	✓	✗
1	1	Sicherung 12V – 125A Fuse	OSK10625		✓	✓	✗
2	2	Kabelschuh 35mm² ø8 Cable lug	EA111500102		✓	✓	✓
3	2	Schrumpfschlauch L=35mm Shrinking tube	EA111501137_35		✓	✓	✓

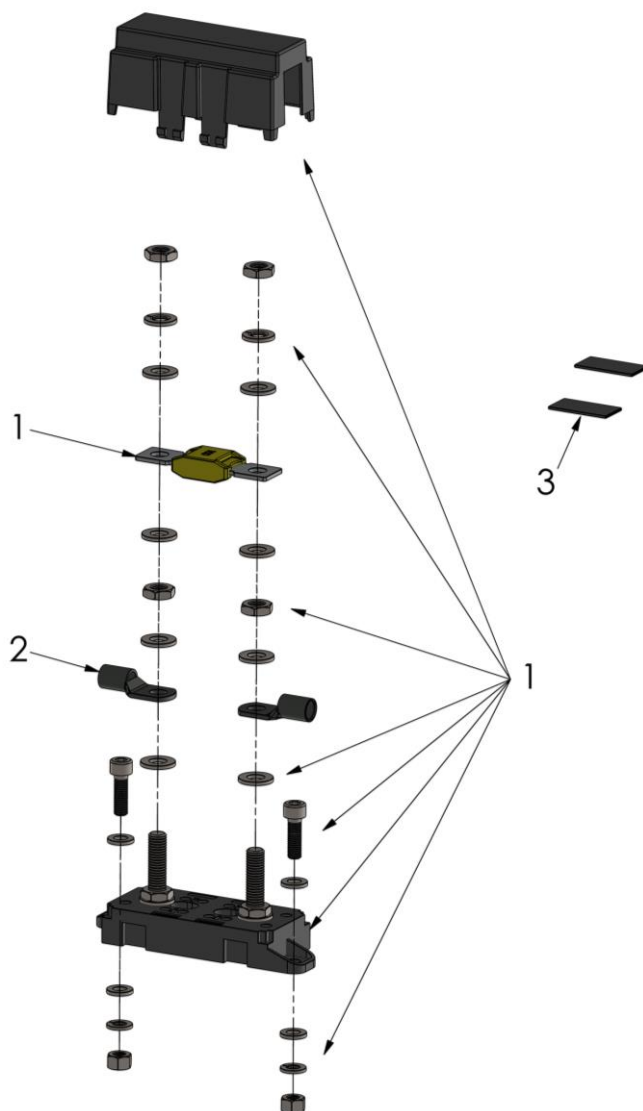

* ULTK-1000ST/AL: Frito Lay
ULTK-1500ST/AL: NDA

13. Stromversorgungskabel / *Power supply cable*

Nr. No.	Stk. Pcs.	Bezeichnung Description	Artikel Nr. Part No.	Zeichnungs Nr. Drawing No.	passend für* suitable for*		
					ULTK-1000 10133-10147	ULTK-1000 10412-10416 10441-10450	ULTK-1500 10473-10492
-	1	Stromversorgungskabel; komplett Power supply cable; assembly	EA111509010		✓	✓	✗
1	1	Kabelschutzschlauch PG-21, L=9,5m Cable protection hose	EA111500167_9500		✓	✓	✗
2	1	Kabel rot (+) 35mm ² , L=10m Cable red	EA111500134_10000		✓	✓	✗
3	1	Kabel schwarz (-) 35mm ² , L=10m Cable black	EA111500080_10000		✓	✓	✗
4	4	Kabelschuh 35mm ² ø8 Cable lug	EA111500102		✓	✓	✓
5	4	Schrumpfschlauch L=35mm Shrinking tube	EA111501137_35		✓	✓	✓

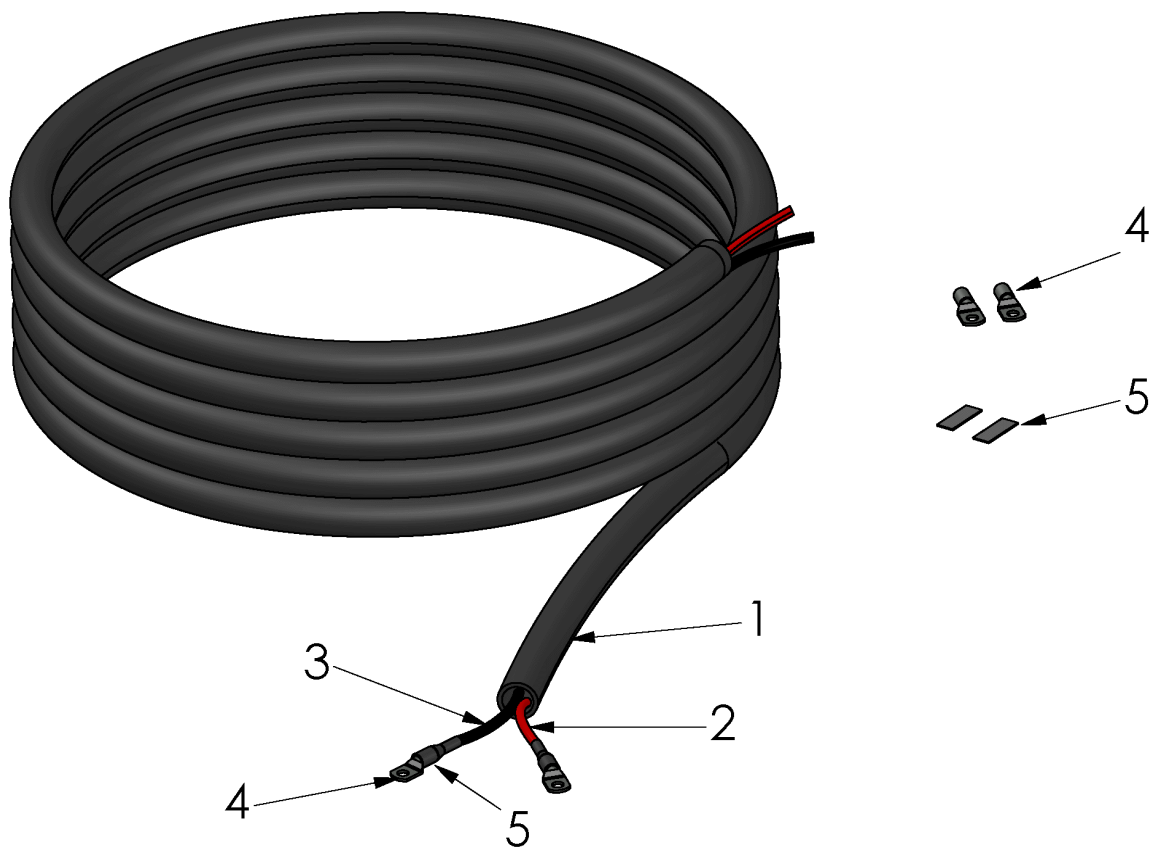

* ULTk-1000ST/AL: Frito Lay
ULTk-1500ST/AL: NDA

Aufklebersatz / *Label set*

Nr. No.	Stk. Pcs.	Bezeichnung Description	Artikel Nr. Part No.	Zeichnungs Nr. Drawing No.	passend für* suitable for*		
					ULTK-1000 10133-10147	ULTK-1000 10412-10416 10441-10450	ULTK-1500 10473-10492
-**	1	Aufklebersatz Label set	K11000615		✓	✓	✓
1**	1	Aggregataufkleber Power pack label	0VK18015		✓	✓	✓
2	1	Aufkleber - Ölstandkontrolle Label - Oil check	0VK18070		✓	✓	✓
3	1	Aufkleber - Bedienung Label - Operation	0VK18008		✓	✓	✓
4	1	Aufkleber - Beachten vor Inbetriebnahme Label - Read before installing power pack	0VK18011		✓	✓	✓
5	1	Aufkleber - Achtung: Gefahrenbereich beachten Label - Caution: Do not stand behind vehicle	K11000192		✓	✓	✓
6	1	Aufkleber - Tanzende Männer Label - Dancing men	K11000307		✓	✓	✓
7	1	Typenschild (leer) mit Nieten Name plate (blank) with rivets	K11000217C		✓	✓	✓

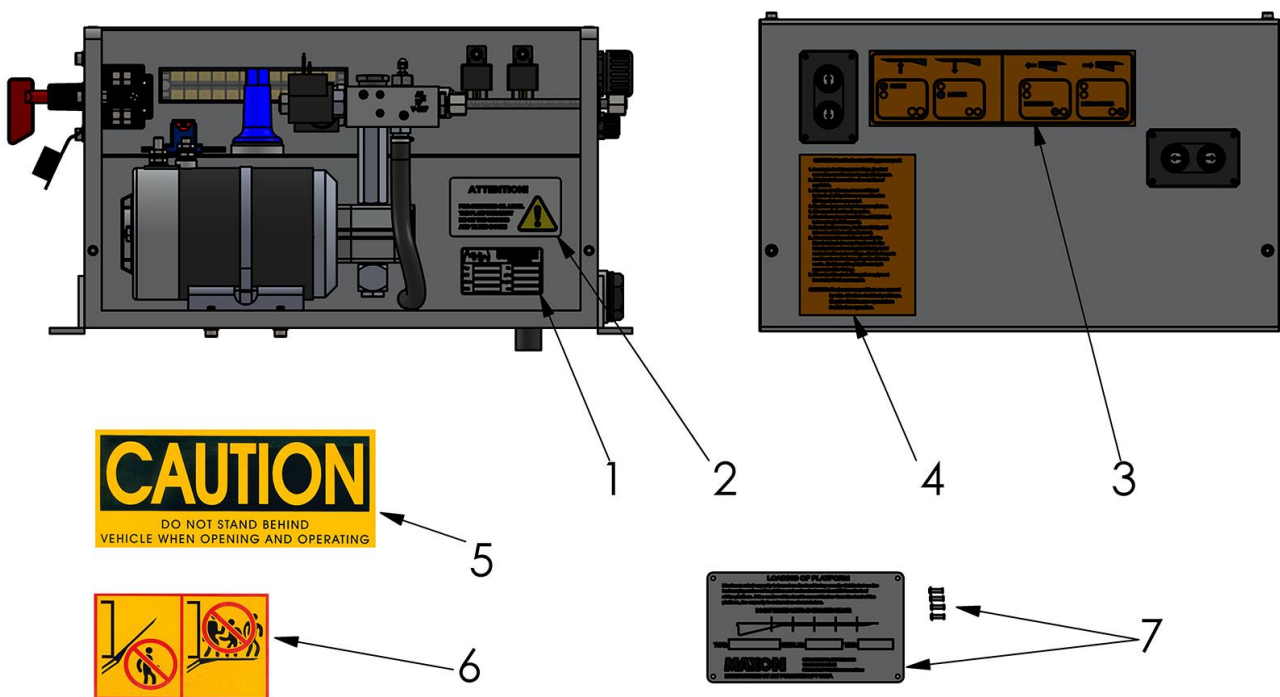

* ULTK-1000ST/AL: Frito Lay
 ULTK-1500ST/AL: NDA

** Seriennummer spezifisch
 Serial number specific

Elektrischer Schaltplan / *Electrical schematic* Im Aggregat / *Inside the power pack*

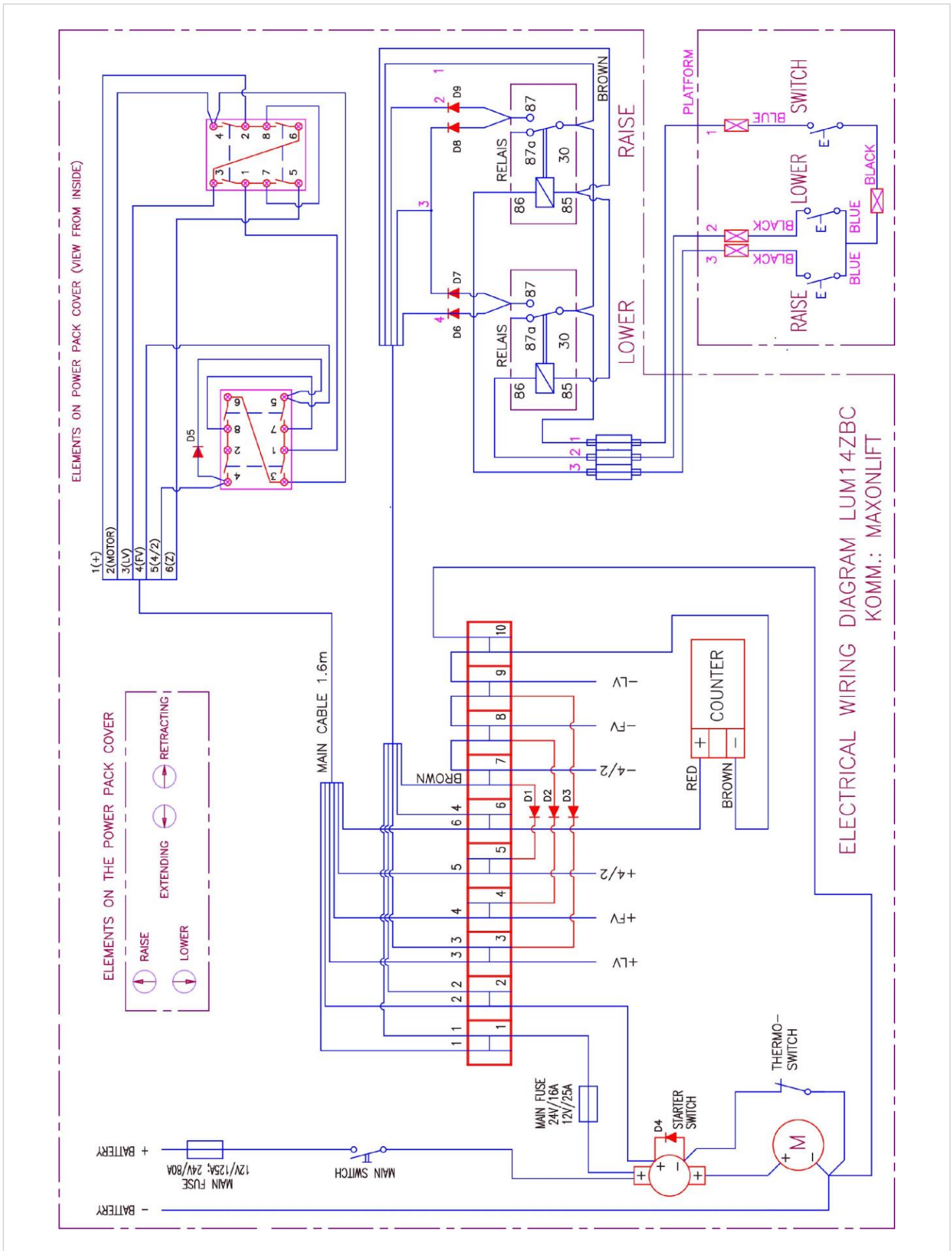

Hydraulischer Schaltplan / *Hydraulic schematic*
 Im Aggregat / *Inside the power pack*

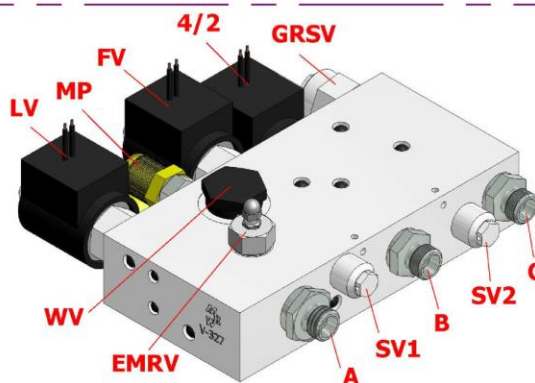
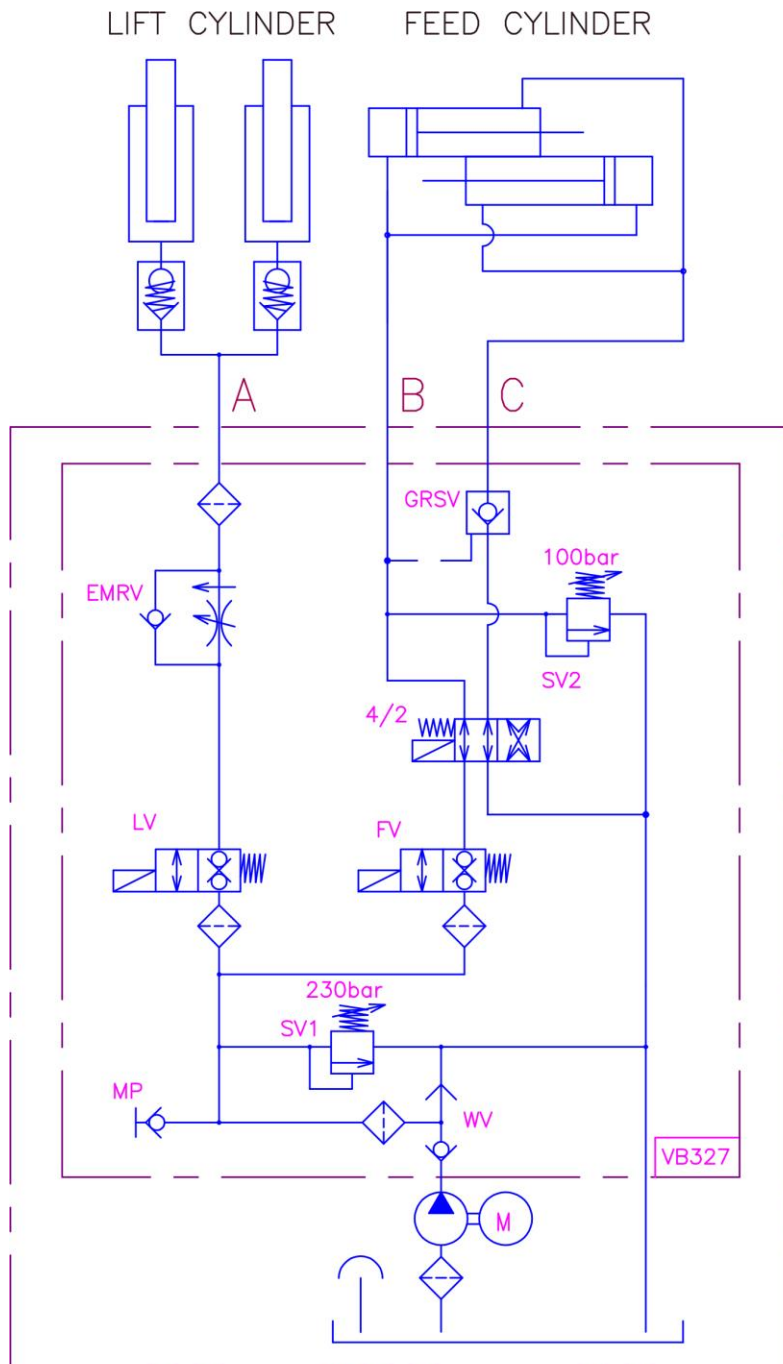

Index

Ladebordwand Tailgate loader	2 - 3
Tragkörper Cross beam	4
Hubwerk Hoisting unit	5
Plateau Platform	6 - 9
3-Knopf-Fußsteuerung 3-Button-Foot-Control	9
Flansch Mounting bracket	10
Führungsschiene Rail	11
Hydraulikleitungen Hydraulic lines	12
Bolzensatz Bolts set	14 - 15
Neigeschwinge Tilting bracket	16
Lenker einstellbar Lever arm adjustable	17
Vorschubzylinder Feed cylinder	18
Lagerbock Bearing block	19
Hubzylinder Lift cylinder	20 - 21
Hydraulikaggregat Power pack	22 - 29
Motor-Pumpen-Einheit Motor-Pump unit	26
Anleitung zum Pumpentausch How to change the hydraulic pump	27
Ventilblock VB-327 Valve block VB-327	28
Aggregatgehäusedeckel Cover for power pack	29
Hauptsicherung Main fuse	30
Stromversorgungskabel Power supply cable	31
Aufklebersatz Label set	32
Elektrischer Schaltplan Electrical schematic	34
Hydraulischer Schaltplan Hydraulic schematic	35