

INSTRUCTIONS, RA ROLLER REPLACEMENT CAM FOLLOWER KIT (2" ROLLER), P/N 295973-02

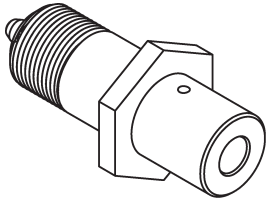

**PIN, CAM FOLLOWER,
1-1/8"-12 THREAD
P/N 295974-02
QTY. 4**

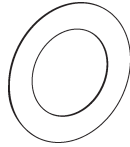

**TEFLON WASHER,
1-3/4" O.D.
P/N 903463-02
QTY. 4**

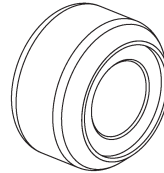

**ROLLER, 1" ID,
2" OD
P/N 295975-02
QTY. 4**

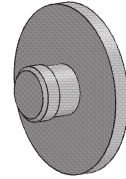

**END CAP, ROLLER
P/N 295962-01
QTY. 4**

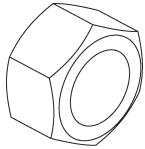

**HEX NUT, THIN, 1-1/8"-12
P/N 903158-01
QTY. 4**

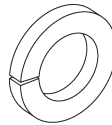

**LOCK WASHER, SPLIT, 1-1/8"
P/N 903457-01
QTY. 2**

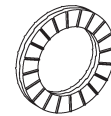

**NORD-LOCK WASHER, 1"/M30
P/N 903435-12
QTY. 2**

CAM FOLLOWER KIT (1-7/8" ROLLER), P/N 295973-01

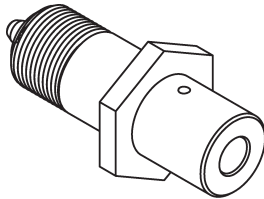

**PIN, CAM FOLLOWER,
1"-14 THREAD
P/N 295974-01
QTY. 4**

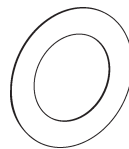

**TEFLON WASHER, 1-3/4" OD
P/N 903463-02
QTY. 4**

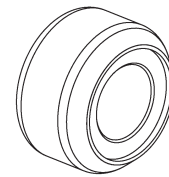

**ROLLER, 1" ID, 1-7/8" OD
P/N 295975-01
QTY. 4**

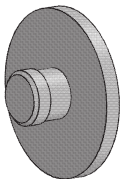

**END CAP, ROLLER
P/N 295962-01
QTY. 4**

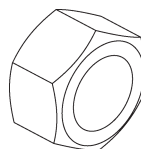

**HEX NUT, THIN, 1"-14
P/N 903157-01
QTY. 4**

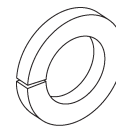

**LOCK WASHER, SPLIT, 1"
P/N 903450-01
QTY. 4**

NOTE: In and out, Front and back are referenced from standing at ramp end of liftgate platform.

1. Refer to **Operation Manual** for detailed operating instructions. Slide out Liftgate all the way (**FIGS. 2-1 and 2-2**). Then, lower platform on to pallet jack or forklift, to support platform (**FIG. 2-3**).

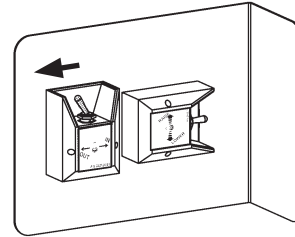

OUT CONTROL SWITCH
FIG. 2-1

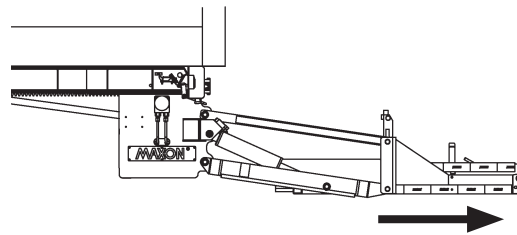

LIFTGATE TRAVELS TO FRONT STOPS
FIG. 2-2



PLATFORM RUN ALL THE WAY PUT OUT & SUPPORTED BY PALLET JACK
FIG. 2-3

2. Remove limit switch lever assembly by removing roll pin (**FIG. 3-1**).



LEVER
(REMOVE)

ROLL PIN
(REMOVE)

REMOVING LIMIT SWITCH LEVER FROM
RH SIDE VEHICLE MOUNT
FIG. 3-1

3. Remove RH-front stop block
(FIG. 4-1). Repeat for LH front
stop block.

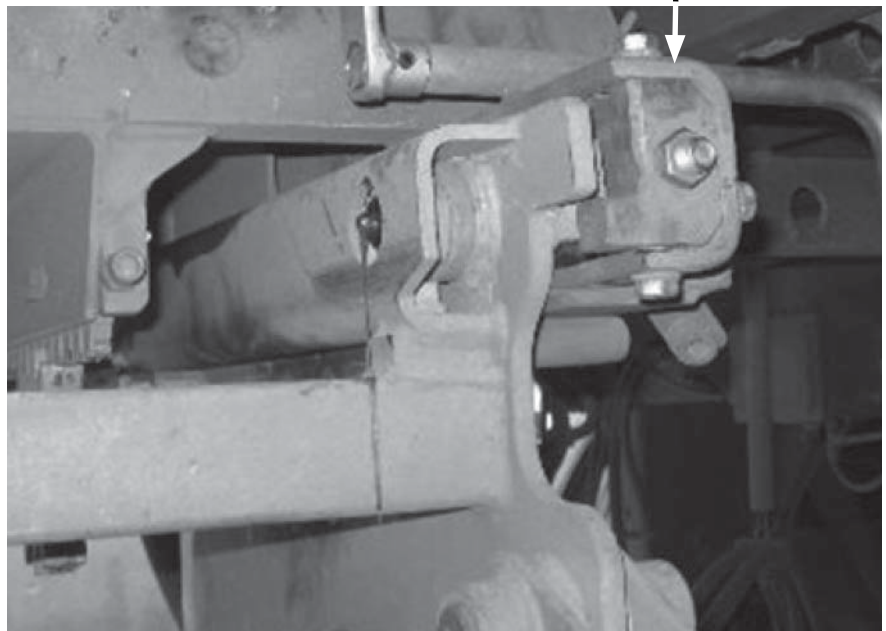
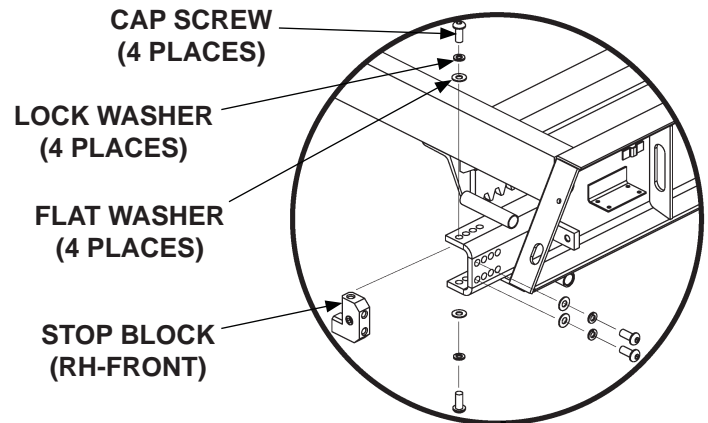

**REMOVING RH-FRONT STOP BLOCK
FIG. 4-1**

NOTE: When the drive pinion gears disengage from the drive racks, pull the slider frame out manually the last few inches, with pallet jack or forklift.

4. To access the front RH and LH rollers, tap the **OUT** control switch (**FIG. 5-1**) to position slider assembly out approximately 6" beyond the usual front stop position (**FIG. 5-2**).

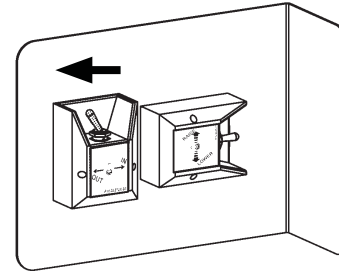

OUT CONTROL SWITCH
FIG. 5-1

5. Use 7/16" hex key wrench to remove hex nut, lock washer, axle pin and roller on RH side (**FIG. 5-2**). Discard these old parts

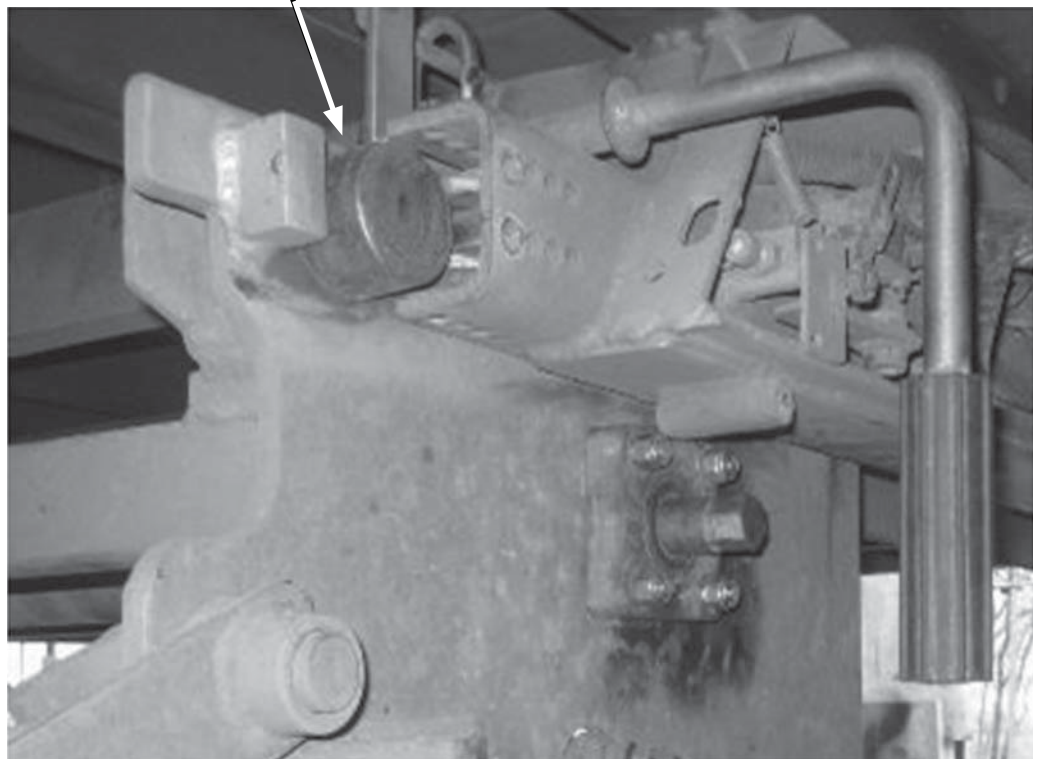
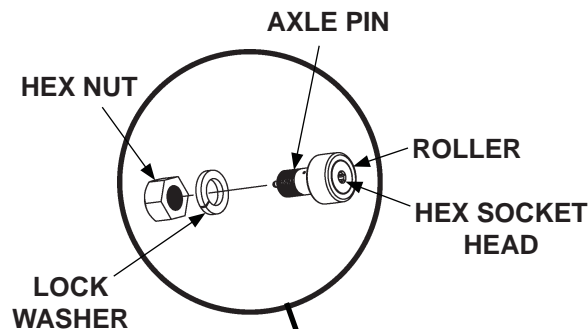

ACCESSING & REMOVING RH FRONT ROLLER
FIG. 5-2

6. Install new cam follower pin with nut and nord-lock washer (**FIG. 6-1B**). Torque pin to **140 lb-ft.**

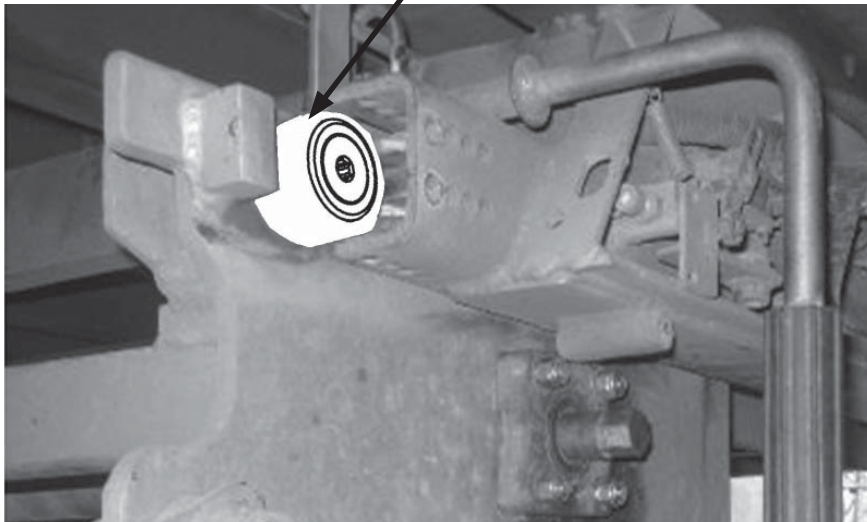
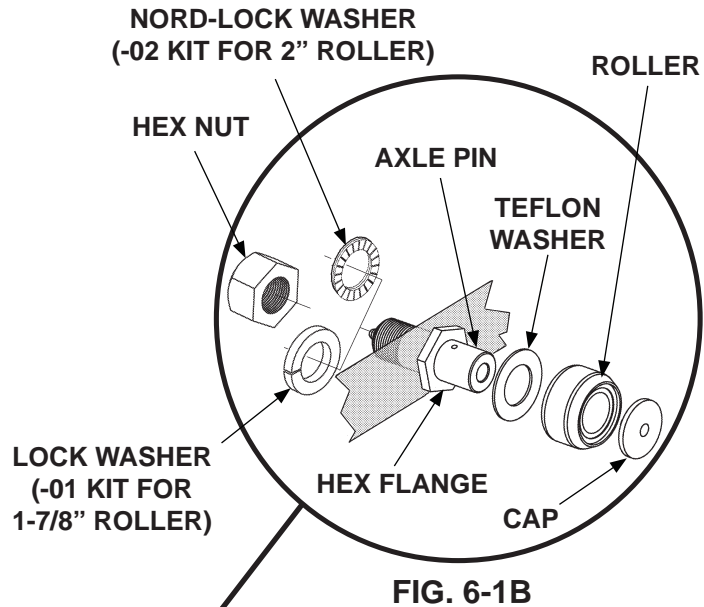

INSTALLING NEW AXLE PIN & ROLLER
FIG. 6-1A

7. Place teflon washer on pin (**FIG. 6-1A**). Next, place roller on pin (**FIGS. 6-1A**). Then, insert plastic cap on the axle pin and roller.
8. Repeat steps 5 through 7 for LH front roller.

NOTE: Push the slider assembly in manually, with pallet jack or forklift, to reengage drive pinion gears with the drive racks.

9. Move slider assembly in, until front rollers are in the tracks on mounting frame, and the drive rack and pinion are engaged. Then, hold in-out switch in the **IN** position (**FIG. 7-1**), to let slider frame travel all the way to the rear stops (**FIG. 7-2**).

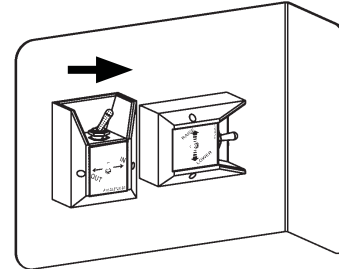

IN CONTROL SWITCH
FIG. 7-1

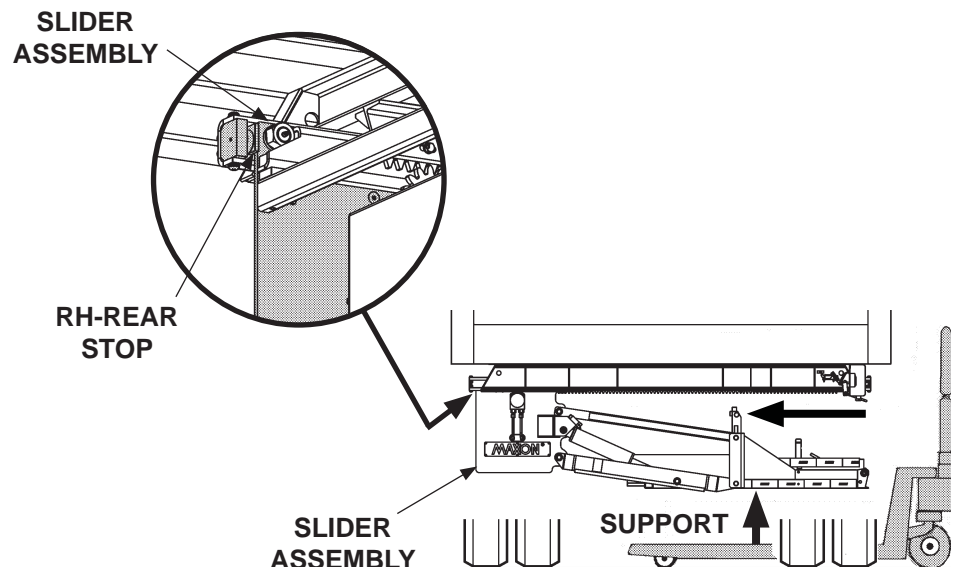

SLIDING PLATFORM IN
FIG. 7-2

10. Reinstall RH-front stop block (**FIG. 8-1**).
Repeat for LH-front stop block.

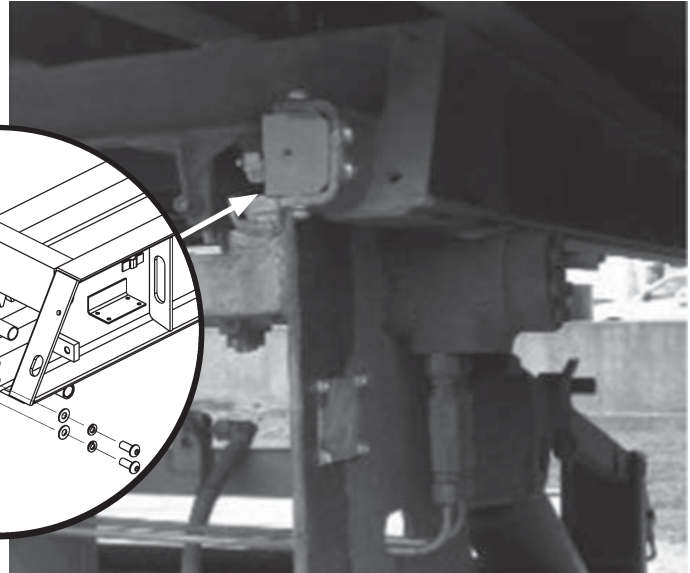
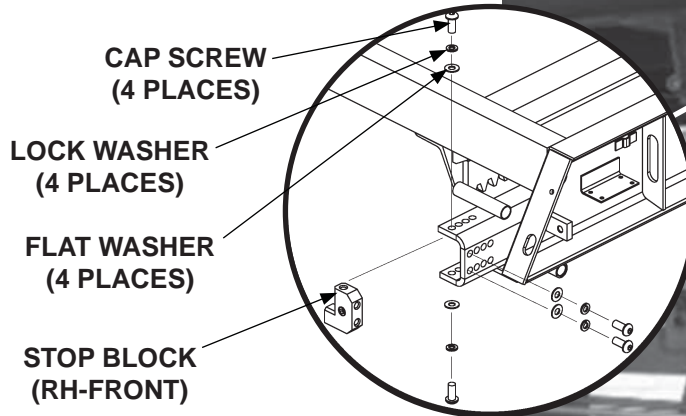

**SLIDER ASSEMBLY ALL THE WAY IN &
FRONT STOP BLOCKS REINSTALLED
FIG. 8-1**

11. Pump EP chassis grease in the lube fitting on the end of the axle pin (**FIG. 8-2**). Stop when grease starts to ooze from roller. Wipe off excess grease with a clean lint-free cloth. Repeat for LH-front roller.

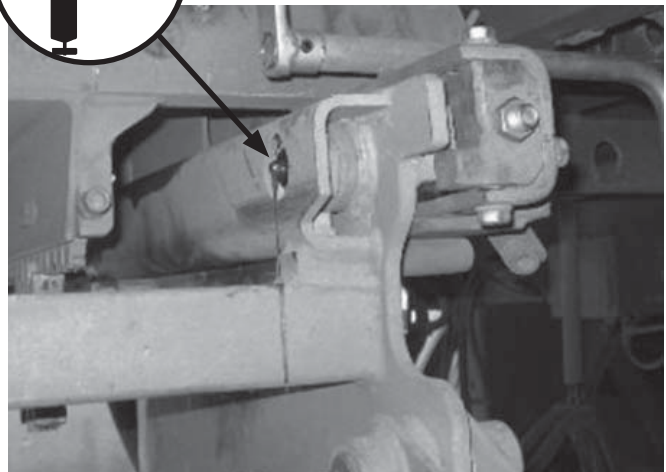
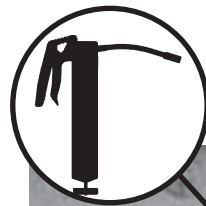

**GREASING NEW ROLLER
FIG. 8-2**

12. Reinstall limit switch lever assembly (**FIG. 9-1**). Secure lever by inserting roll pin.

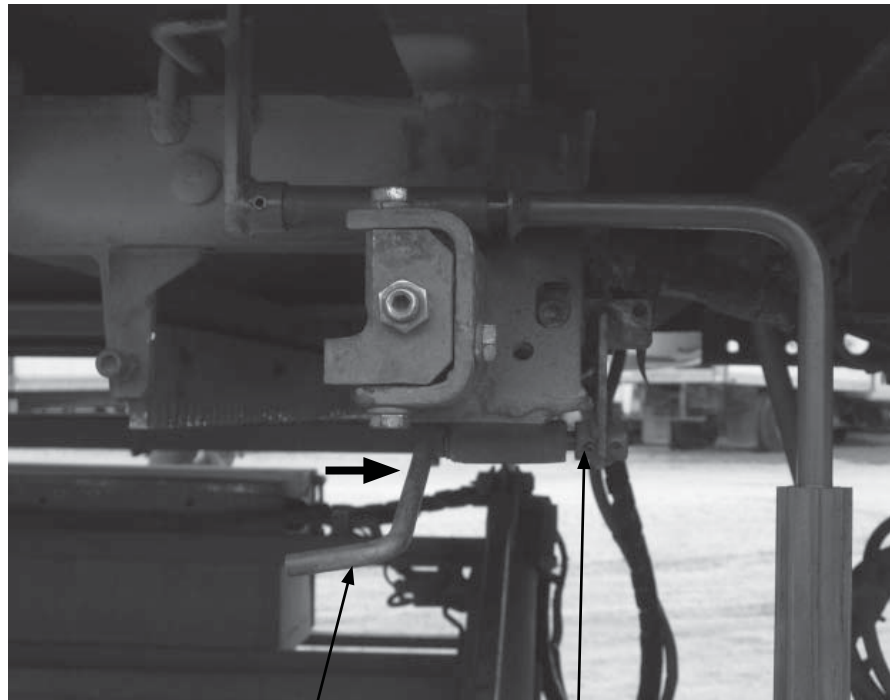

LEVER
(REINSERT)

ROLL PIN
(REINSERT)

REINSTALLING LIMIT SWITCH LEVER ON
RH SIDE VEHICLE MOUNT
FIG. 9-1

13. Remove RH-rear stop block
(FIG. 10-1). Repeat for LH-
rear stop block.

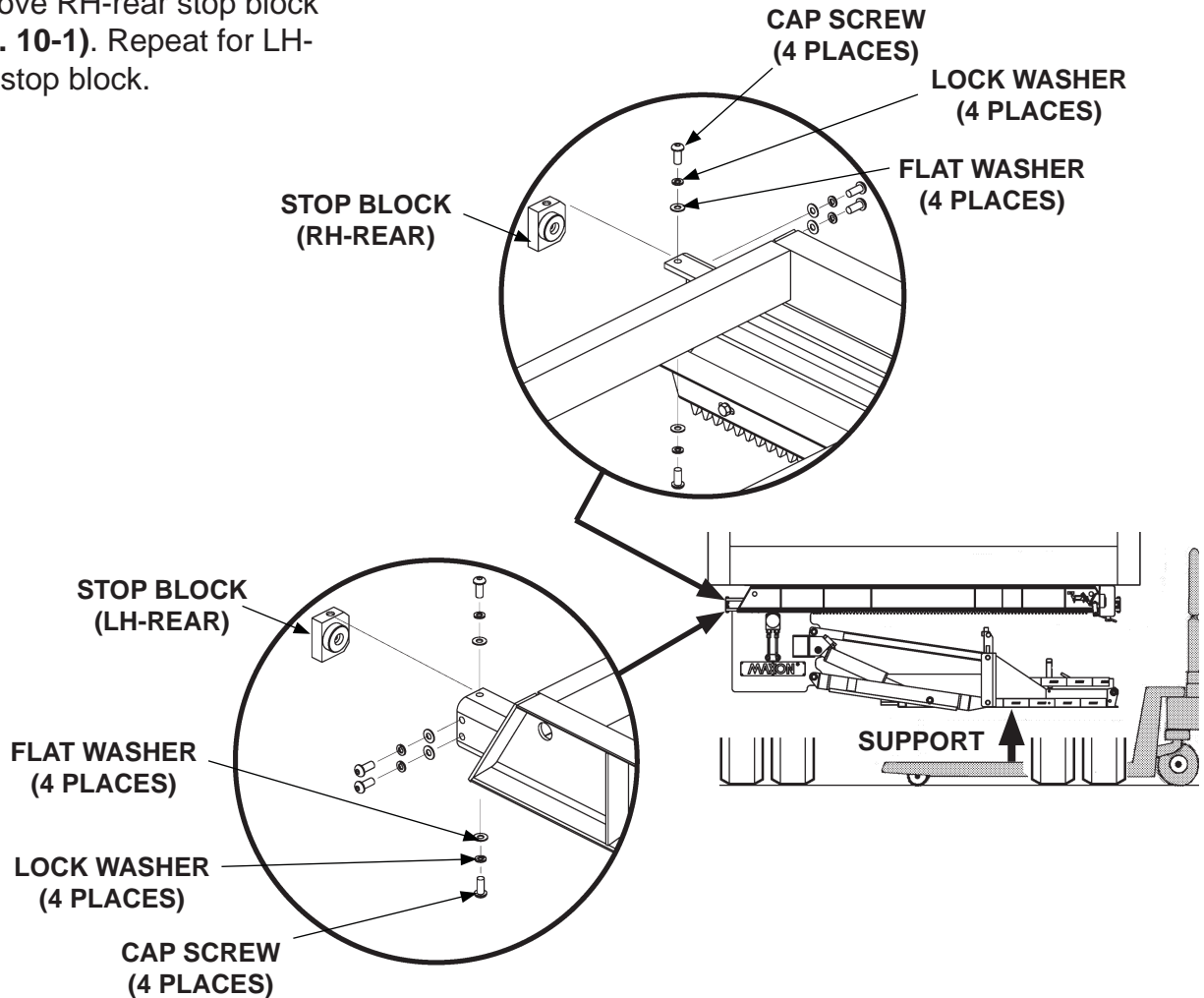

REMOVING REAR STOP BLOCKS
(REAR OF VEHICLE SHOWN, SLIDER ALL THE WAY IN)
FIG. 10-1

NOTE: When the drive pinion gears disengage from the drive racks, push the slider frame out the rear, manually the last few inches, with pallet jack or forklift.

14. To access the RH and LH rollers, tap the **IN** control switch (**FIG. 11-1**) to position slider assembly out approximately 6" beyond the usual rear stop position.

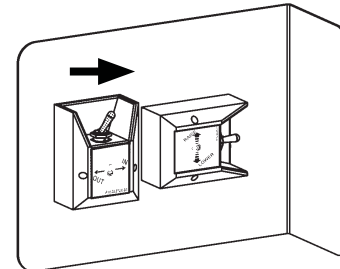

**IN CONTROL SWITCH
FIG. 11-1**

15. Use 7/16" hex key wrench to remove hex nut, lock washer, axle pin and roller on RH-rear of slider assembly (**FIG. 11-2**). Repeat for LH-rear roller. Discard these old parts

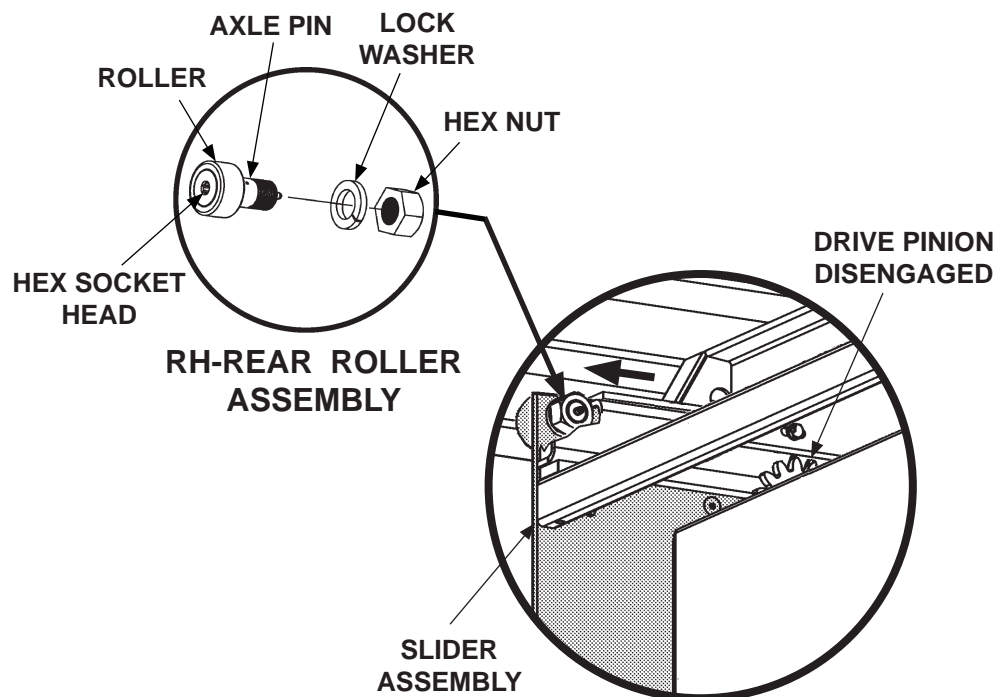

**GAINING ACCESS TO REMOVE
RH-REAR ROLLER
FIG. 11-2**

16. Install new cam follower pin with nut and split lock washer (**FIG. 12-1**). Torque pin to **140 lb-ft**.

17. Place teflon washer on pin (**FIG. 12-1**). Next, place roller on pin (**FIG. 12-1**). Then, insert plastic cap on the axle pin and roller.

18. Repeat steps 15 through 17 for LH-front roller.

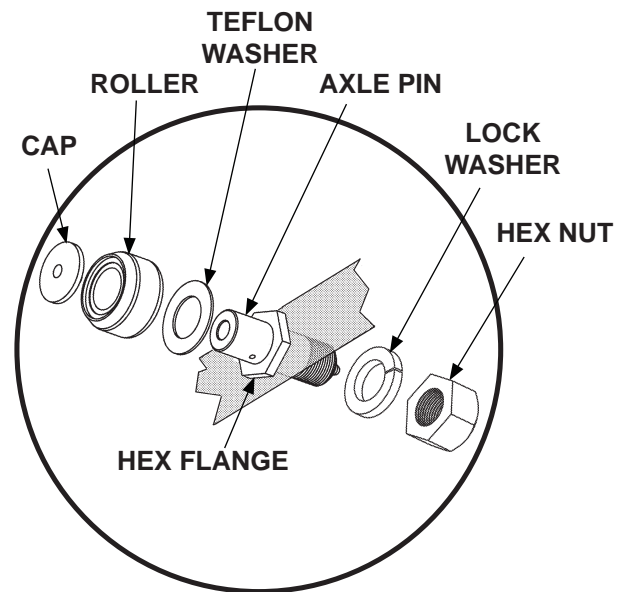

**INSTALLING CAM FOLLOWER
ROLLER KITS
FIG. 12-1**

NOTE: Push the slider assembly in manually, with pallet jack or forklift, to reengage drive pinion gears with the drive racks.

19. Move slider assembly to reinsert rear rollers in tracks on mounting frame, and to engage the drive rack and pinion (**FIGS. 13-2A and 13-2B**). When the drive rack and pinion are engaged, tap the in-out switch to **OUT** position (**FIG. 13-1**), until tracks are clear to reinstall rear stop blocks (**FIG. 13-2B**).

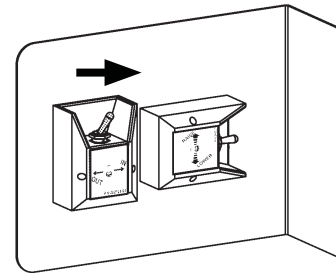

OUT CONTROL SWITCH
FIG. 13-1

20. Reinstall RH-rear stop block (**FIG. 13-2C**). Repeat for LH-rear stop block (**FIG. 13-2D**).

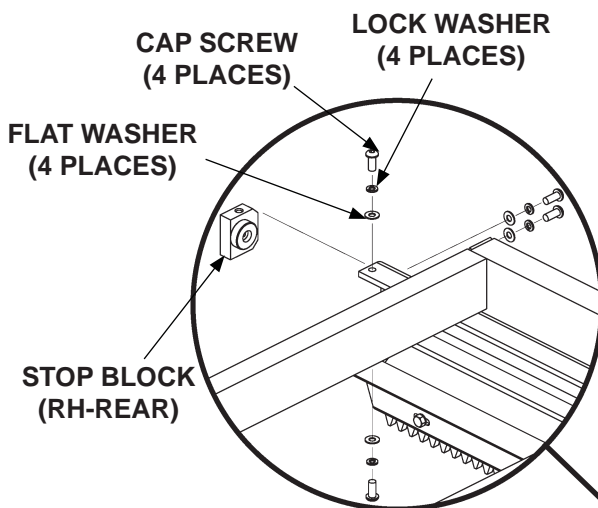

FIG. 13-2C

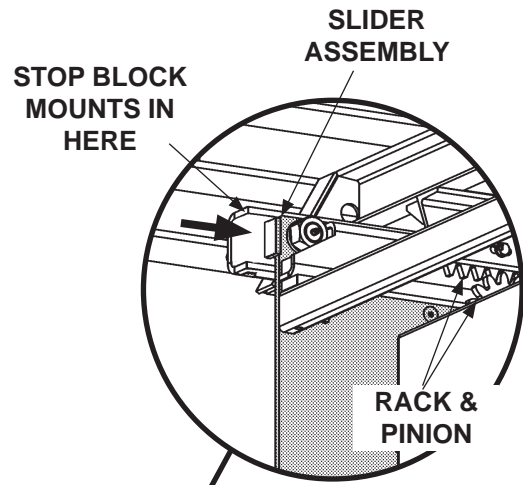

FIG. 13-2B

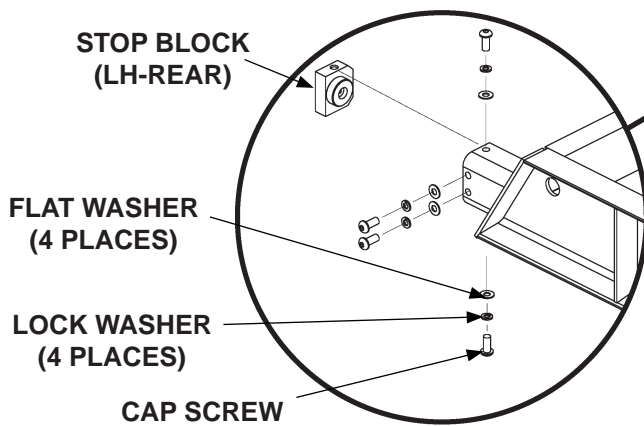
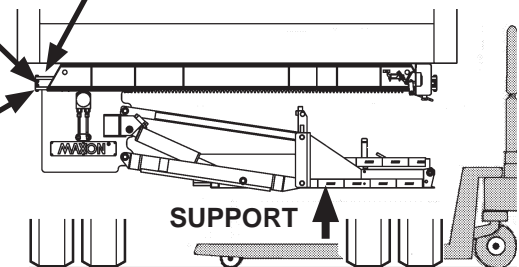
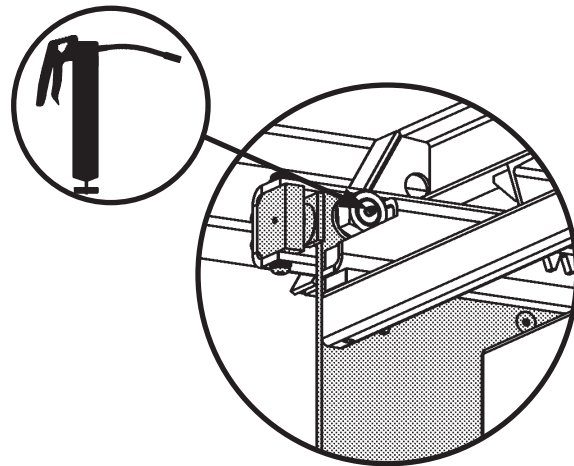

FIG. 13-2D



REINSTALLING REAR STOP BLOCKS
(REAR OF VEHICLE SHOWN)
FIG. 13-2A

21. Pump EP chassis grease in the lube fitting on the end of the axle pin (**FIG. 14-1**). Stop when grease starts to ooze from roller. Wipe off excess grease with a clean lint-free cloth. Repeat for LH-front roller.



GREASING ROLLERS
FIG. 14-1

22. Move pallet jack or forklift clear of the Liftgate and vehicle.

23. Check operation with new rollers by running the slider assembly all the way out and all the way in (**FIG. 14-2**). Refer to **Operation Manual** for detailed operating instructions.

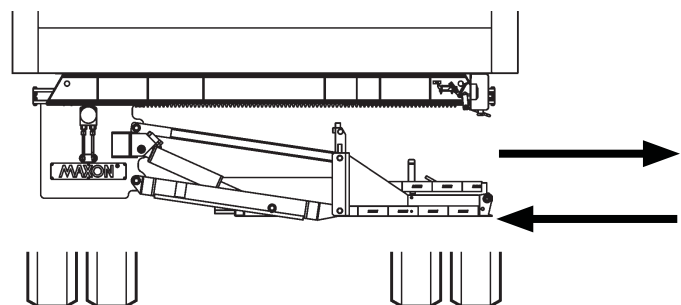

CHECK LIFTGATE OPERATION
FIG. 14-2