

M-16-39
JUNE 2018

MAXON[®]

DMD Series

OPERATION MANUAL DMD-22 & DMD-33

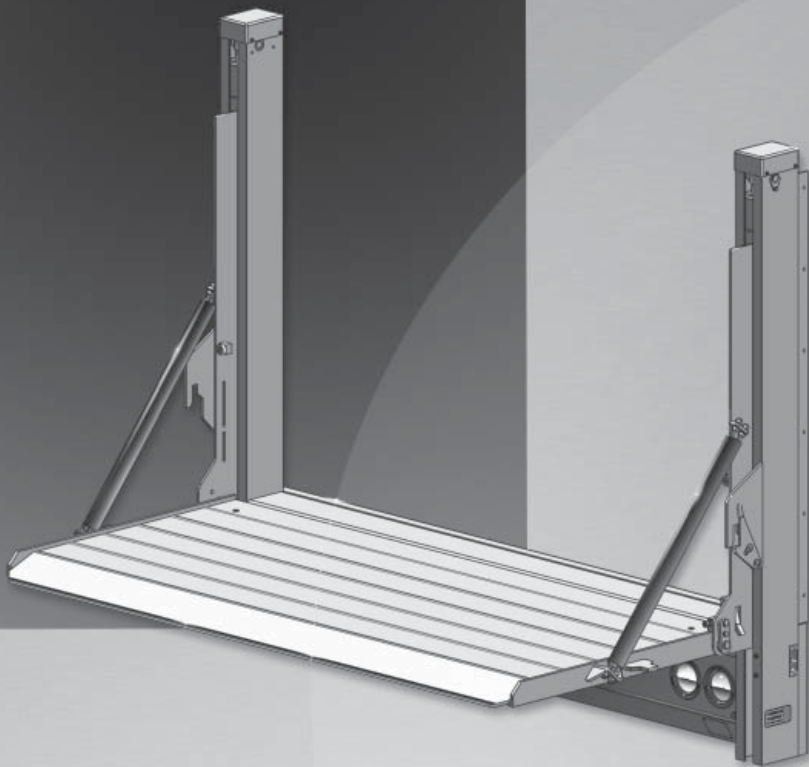

To find **maintenance & parts** information for your **DMD Liftgate**, go to www.maxonlift.com. Click the **PRODUCTS, RAILIFT & DMD** buttons. Open the **Maintenance Manual** in the **PRODUCT DOCUMENTATION** window. For parts, click on the **PARTS PORTAL, RAILIFT & DMD** buttons.

TABLE OF CONTENTS

WARNINGS	5
LIFTGATE TERMINOLOGY	6
DECALS & PLATES	7
FORKLIFT ADVISORY	9
OPERATION	10
UNFOLDING THE PLATFORM.....	10
LOADING VEHICLE	14
LOWERING THE PLATFORM	14
POSITIONING LOAD	14
RAISING & UNLOADING PLATFORM.....	15
UNLOADING VEHICLE.....	16
LOWERING THE PLATFORM	16
RAISING THE PLATFORM	16
POSITIONING LOAD	17
LOWERING & UNLOADING PLATFORM.....	18
STOWING PLATFORM.....	19
USING STANDARD CART STOPS (IF EQUIPPED)	22
USING RETENTION RAMP (IF EQUIPPED).....	25

THIS PAGE INTENTIONALLY LEFT BLANK

WARNING

1. Incorrect operation of this Liftgate can result in serious personal injury. Comply with **WARNINGS** and Liftgate operating instructions in this manual. Do not allow untrained persons or children to operate the Liftgate. If you need to replace an **Operation Manual**, additional copies are available from:

MAXON Lift Corp. Customer Service
11921 Slauson Ave
Santa Fe Springs, CA 90670
(800) 227-4116

2. Do not exceed rated **load capacity of 2200 lb for DMD-22 Liftgate, and 3300 lb for DMD-33 Liftgate.**
3. Do not allow any part of your body to be placed under, within, or around any portion of the moving Liftgate or its mechanisms, or in a position that would trap them between the platform and the floor of truck body (or between platform and the ground) when Liftgate is operated.
4. Consider the safety and location of bystanders and location of nearby objects when operating the Liftgate. Stand to one side of platform while operating the Liftgate. Be certain that the area the Liftgate will move through during operation is clear of all obstacles.
5. Comply with all attached instruction decals and warning decals.
6. Keep decals clean and legible. If decals are illegible or missing, have them replaced. **Get free replacement decals from Maxon.**
7. **Never drive a forklift on the Liftgate platform.**
8. Do not move vehicle unless Liftgate is correctly stowed.
9. **Correctly stow platform when not in use. Extended platforms could create a hazard for people and vehicles passing by.**
10. A correctly installed Liftgate will operate smoothly and reasonably quiet. The only noticeable noise during Liftgate operation is from the power unit while the platform is being lowered and raised. Listen for scraping, grating and binding noises and have the problem corrected before continuing to operate the Liftgate.
11. Above all, **USE GOOD COMMON SENSE** when operating this Liftgate.
12. Never use a cell phone while operating the Liftgate.

LIFTGATE TERMINOLOGY

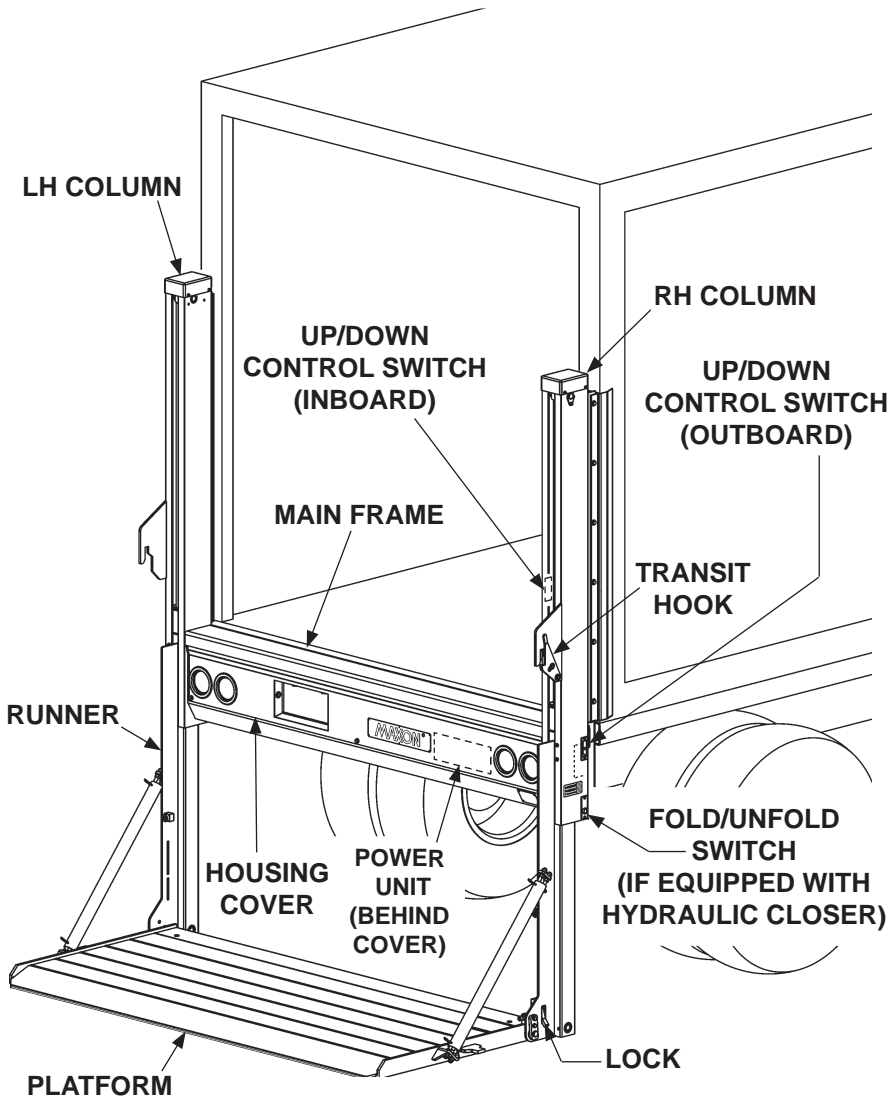

DECALS & PLATES

NOTE: Ensure there is no residue, dirt, or corrosion where decals are attached. If necessary, clean surface before attaching decals.

THE MAXIMUM CAPACITY OF THIS LIFT IS
2200 LB [1000 KG]
 WHEN THE LOAD IS CENTERED ON THE LOAD CARRYING PLATFORM
P/N 220388-03

DMD-22 ONLY
CAPACITY DECAL
P/N 220388-03

THE MAXIMUM CAPACITY OF THIS LIFT IS
3300 LB [1500 KG]
 WHEN THE LOAD IS CENTERED ON THE LOAD CARRYING PLATFORM
P/N 220388-02

DMD-33 ONLY
CAPACITY DECAL
P/N 220388-02

DECAL "F" OR "G"

DECAL "E"
 DECAL "D"
 WARNING DECAL
 P/N 298373-01
 DECAL "B"
 DECAL "A"
 DECAL "C"



FAMILY OWNED DECAL
P/N 283445-01

Align arrows before folding or unfolding.
P/N 289192-01

COLUMN ARROW DECAL "H"
P/N 289192-01

RUNNER ARROW DECAL "H"
P/N 289192-01

WARNING DECAL
P/N 299274-01

WARNING
 Liftgate hazards can result in crushing or falling.
 Keep hands and feet clear of pinch points.
 If raising liftgate, make sure load is stable and footing is solid.

Advertencia
 Existe riesgo de caer debido a ser presionado por el elevador.
 Mantenga manos y pies fuera de las zonas de plegue.
 Asegúrese de tener la carga estable y un sólido paradero firmemente sobre el elevador.

Read and understand all instructions and warnings before use. Lea y comprenda todas las instrucciones y advertencias antes de usarlo.

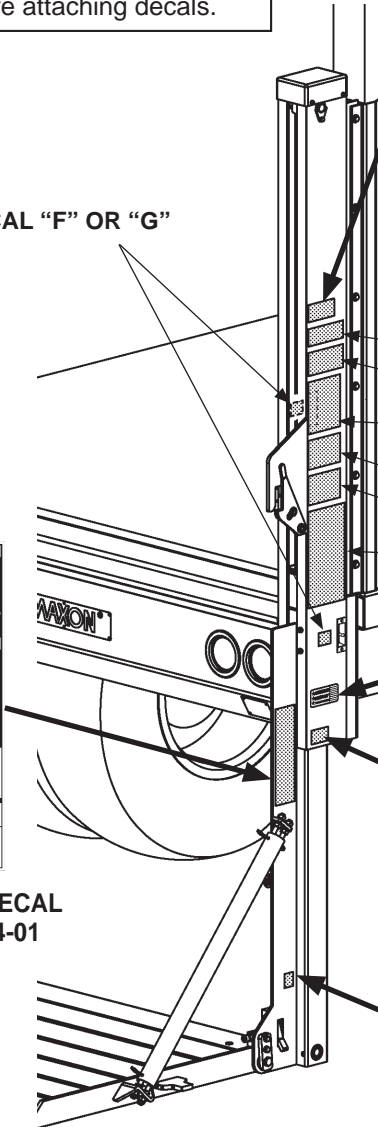

DECALS

SAFETY INSTRUCTIONS

Read all decals and operation manual before operating liftgate.

1. Do not use liftgate unless you have been properly instructed and have read, and are familiar with, the operating instructions.
2. Be certain vehicle is properly and securely braked before using the liftgate.
3. Always inspect this liftgate for maintenance or damage before using it. Do not use liftgate if it shows any sign of damage or improper maintenance.
4. Do not overload.
5. Make certain the area in which the platform will open and close is clear before opening or closing the platform.
6. Make certain platform area, including the area in which loads may fall from platform, is clear before and at all times during operation of liftgate.
7. This liftgate is intended for loading and unloading of cargo only. Do not use this liftgate for anything but its intended use.

P/N 289192-01 (A)

CAUTION

Always stand clear of platform area.

P/N 289192-01 (B)

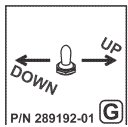
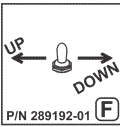

WARNING

Liftgate hazards can result in crushing or falling.

Keep hands and feet clear of pinch points.

If riding liftgate, make sure load is stable and footing is solid.

(D)

Read and understand all instructions and WARNINGS before use.

Align arrows before folding or unfolding.

(H)

Cut at dotted line. Discard this piece.

WARNING

Read this information carefully.

- Improper operation of this Liftgate can result in serious personal injury. If you do not have a copy of the operating instructions, please obtain them from your employer, distributor, or lesser before you attempt to operate Liftgate.
- If there are signs of improper maintenance, damage to vital parts, or slippery platform surface, do not use the Liftgate until these problems have been corrected.
- If you are using a pallet jack, be sure it can be maneuvered safely.
- Do not operate a forklift on the platform.
- Do not allow any part of yours or your helper's body to be placed under, within, or around any portion of the moving Liftgate, or its mechanisms, or in a position that would trap them between the platform and the ground or truck when the Liftgate is operated.
- If a helper is riding the platform with you, make sure you are both doing so safely and that you are not in danger of coming in contact with any moving or potentially moving obstacles.
- **USE GOOD COMMON SENSE**
- If load appears to be unsafe, do not lift or lower it.

For a free copy of other manuals that pertain to this model Liftgate, please visit our website at www.manitoull.com or call Customer Service at (800) 227-4116. P/N 289192-01 (B)

OPERATING INSTRUCTIONS

OPERATE	STOW
<p>RAISE PLATFORM OFF TRANSIT HOOK & LOWER TO UNLOCK.</p> <p>1</p>	<p>FOLD & LOCK FLIPOVER IF EQUIPPED.</p> <p>1</p>
<p>LOWER PLATFORM AT OR BELOW ARROW ALIGNMENT.</p> <p>2</p>	<p>RAISE PLATFORM AT OR BELOW ARROW ALIGNMENT.</p> <p>2</p>
<p>RELEASE PLATFORM LOCK & UNFOLD.</p> <p>IF EQUIPPED WITH MANUAL CLOSURE</p> <p>3</p>	<p>RELEASE PLATFORM LOCK & FOLD.</p> <p>IF EQUIPPED WITH MANUAL CLOSURE</p> <p>3</p>
<p>UNLOCK & UNFOLD FLIPOVER IF EQUIPPED.</p> <p>4</p>	<p>RAISE PLATFORM ABOVE TRANSIT HOOK.</p> <p>4</p>
<p>RAISE LOWER PLATFORM.</p> <p>5</p>	<p>MAKE SURE TRANSIT HOOK RETURNS TO POSITION.</p> <p>5</p>

P/N 289192-01 (C)

DECAL SHEET P/N 289192-01

WARNING

A liftgate extending from a moving vehicle could injure bystanders & damage property. Stow liftgate in correct transit position before moving vehicle.

Advertencia

Un elevador hidráulico abierto en vehículo en movimiento puede ocasionar daños y lesiones a objetos y personas circundantes. Cierre apropiadamente antes de poner el vehículo en movimiento.

P/N 289373-01

WARNING

Liftgate hazards can result in crushing or falling.

Keep hands and feet clear of pinch points.

If riding liftgate, make sure load is stable and footing is solid.

Advertencia

Existe riesgo de caer desde o ser prensado por el elevador.

Mantenga manos y pies fuera de las zonas de plegaje.

Asiguresse de tener la carga estable y estivo parado firmemente sobre el elevador.

Read and understand all instructions and warnings before use. Lea cuidadosamente todas las instrucciones y ADVERTENCIAS antes de operar.

**WARNING DECAL
P/N 298373-01**

**WARNING DECAL
P/N 299274-01**

FORKLIFT ADVISORY

⚠ WARNING
Keep forklift OFF of platform.

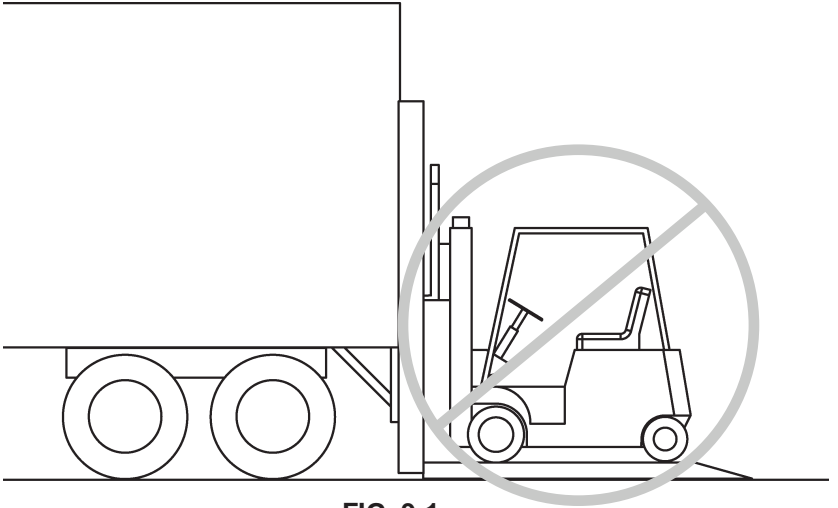

FIG. 9-1

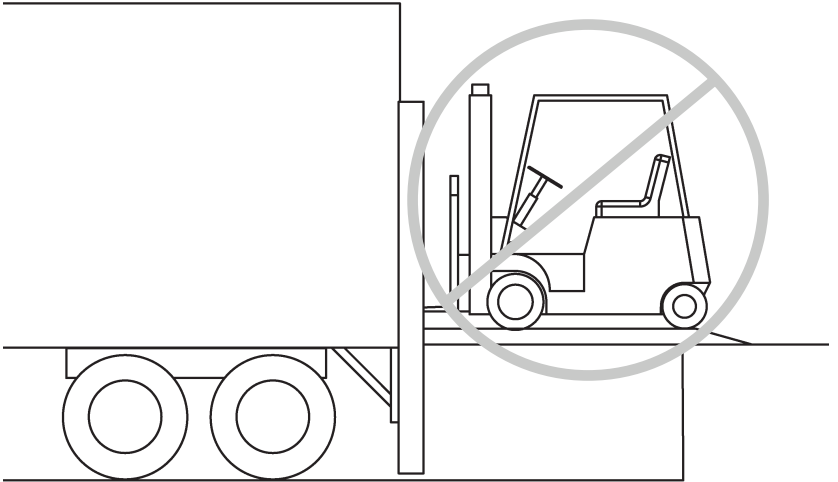

FIG. 9-2

OPERATION

UNFOLDING THE PLATFORM

1. Raise platform stop off transit hook (FIG. 10-1A) by pushing the outboard control switch to (UP) position (FIG. 10-1).

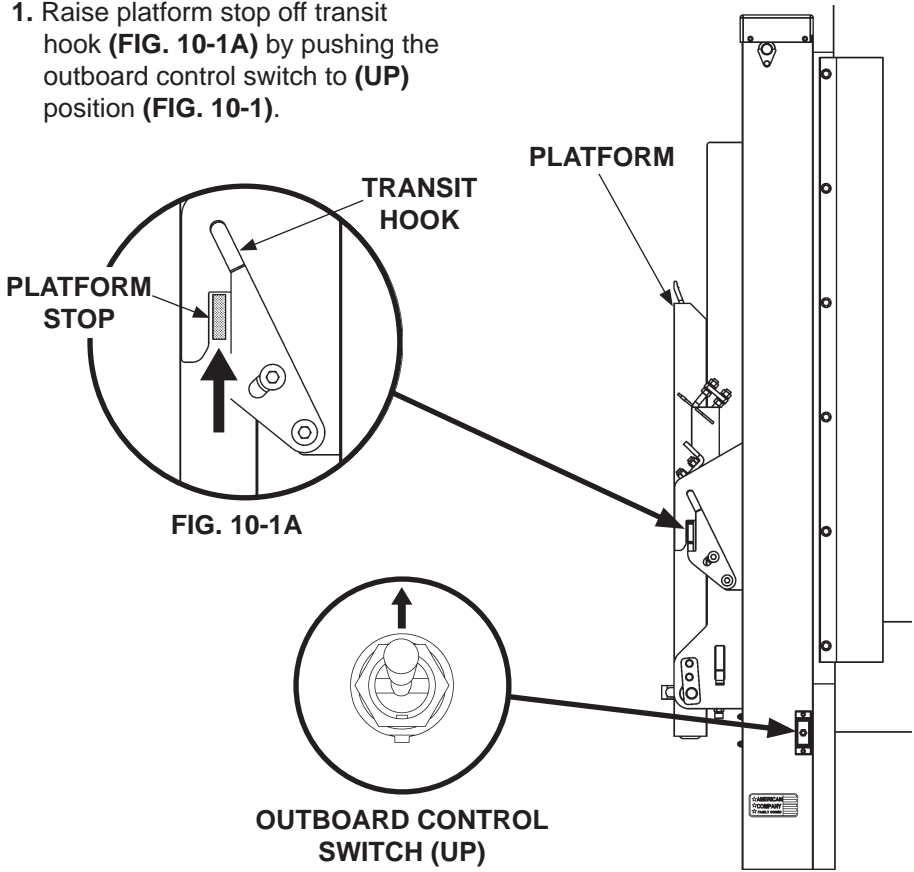

FIG. 10-1

2. Rotate transit hook away from platform stop (**FIG. 11-1A**). Push outboard control switch **DOWN** (**FIG. 11-1**) to lower the platform slightly until platform stop clears transit hook.

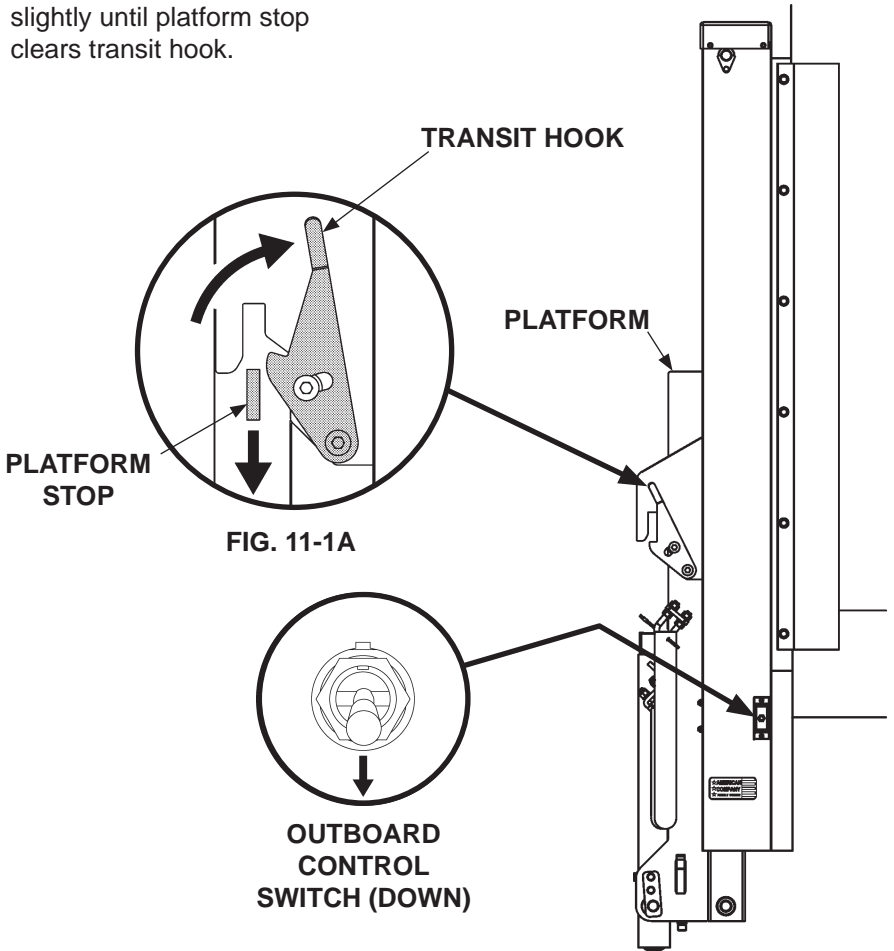
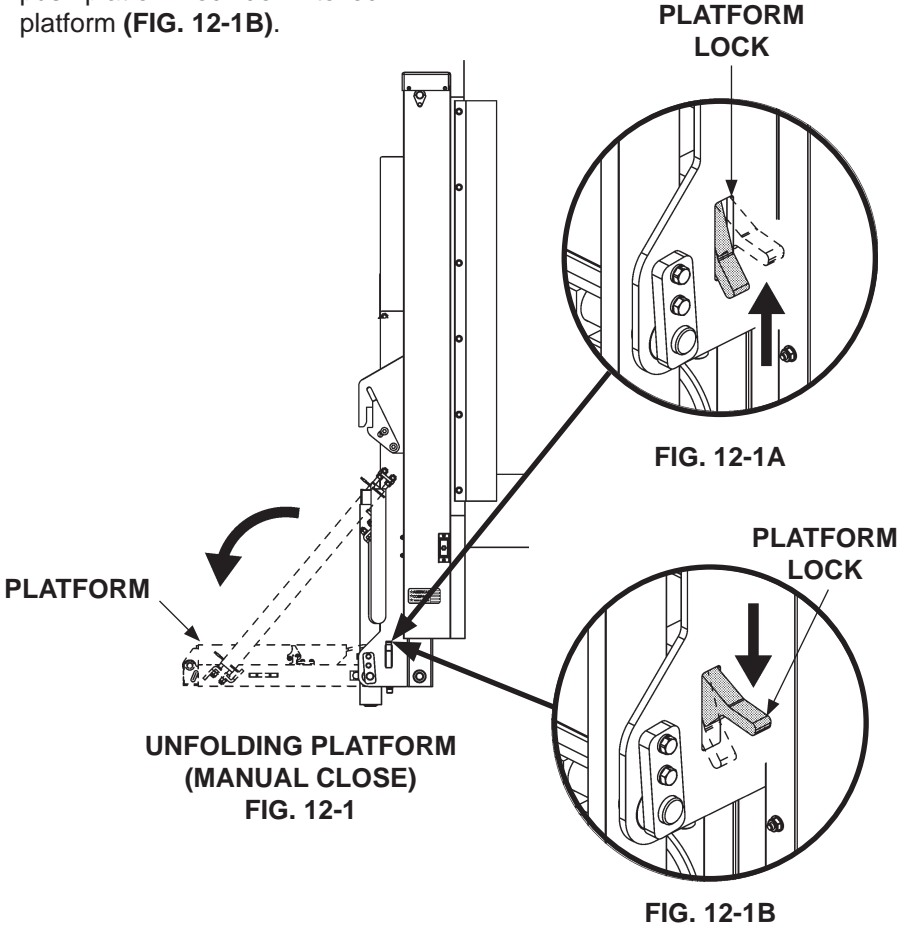

FIG. 11-1

UNFOLDING THE PLATFORM - Continued

NOTE: If platform is equipped with hydraulic closer, do step 4.

3. For manual close Liftgate, push platform lock up to unlock the platform (**FIG. 12-1A**). Manually unfold platform (**FIG. 12-1**). Next, push platform lock down to lock platform (**FIG. 12-1B**).



4. For Liftgate equipped with hydraulic closer, hold power closer switch (**FIG. 15-1**) and lower outboard control switch (**DOWN**) at the same time to unfold platform (**FIG. 13-1**).

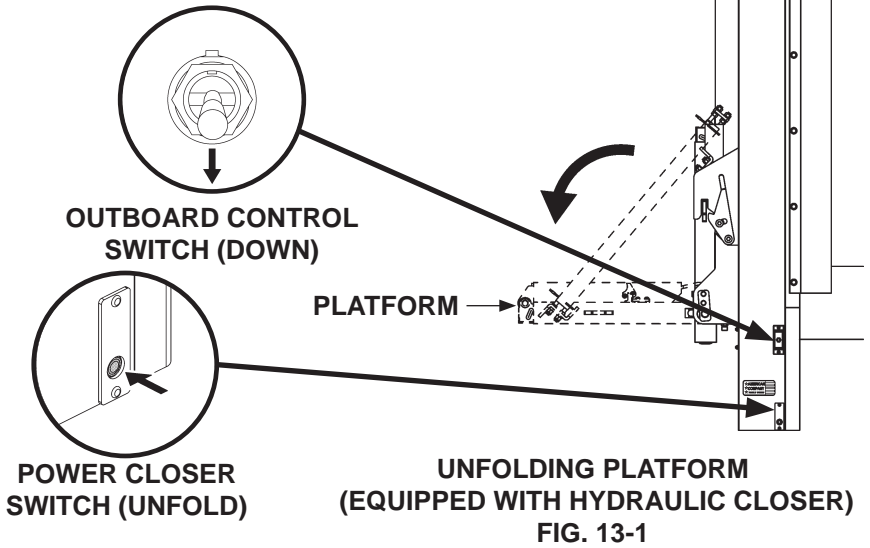

5. Unlock and unfold flipover (if equipped) (**FIG. 13-2**).

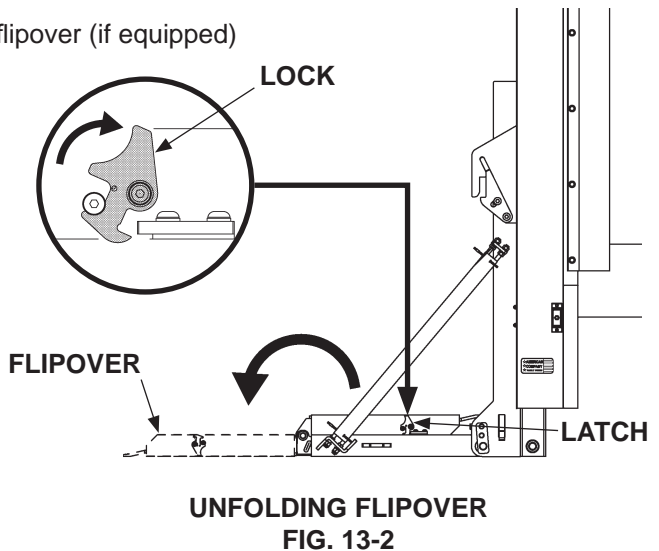

LOADING VEHICLE LOWERING THE PLATFORM

Use outboard control switch to lower (**DOWN**) platform (**FIG. 14-1**). Release toggle switch when platform reaches the ground.

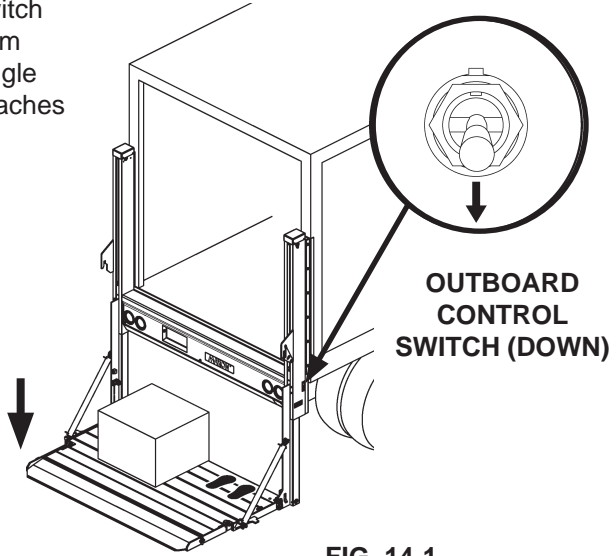

FIG. 14-1

POSITIONING LOAD

⚠ WARNING

A load should never extend past the edges of the platform. Do not place unstable loads on platform and do not allow load to exceed lifting capacity of Liftgate. If standing on platform, do not allow your feet to extend beyond inboard edge of platform.

Place all loads as close as possible to the inboard edge of the platform with heaviest part toward the truck body as shown in **FIG. 14-2**. Move loads across the ramp (**FIG. 14-2**) to the platform, but never rest or raise loads on the ramp. If standing on platform with the load, stand in the footprint area shown and comply with the preceding **WARNING**.

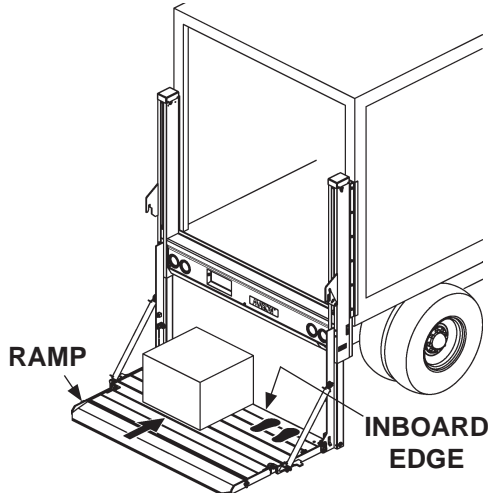

LOADING PLATFORM AT GROUND LEVEL

FIG. 14-2

RAISING & UNLOADING PLATFORM

⚠ CAUTION

A ramp in retention position can trip you when stepping over it. To prevent possible injury, get on the platform before putting the ramp in retention position.

1. Use inboard control switch to raise (**UP**) platform from ground level to bed height (**FIG. 15-1**). Release toggle switch when platform reaches bed height.

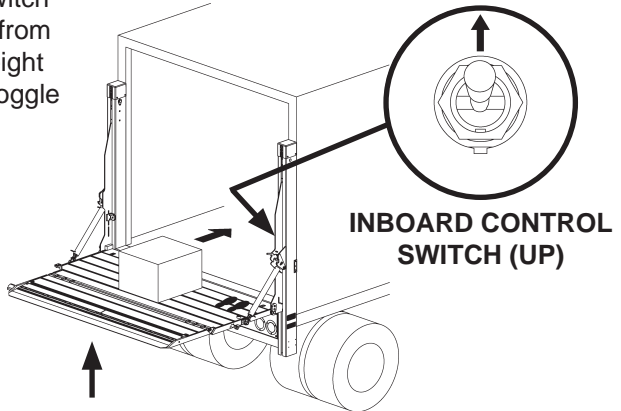

2. Carefully move the load into vehicle (**FIG. 15-1**).

MOVING LOAD INTO VEHICLE
FIG. 15-1

3. Use inboard control switch to lower (**DOWN**) the platform to ground level (**FIG. 15-2**).

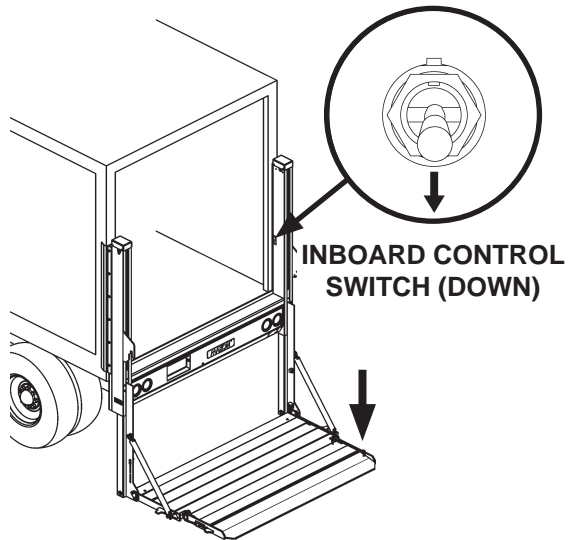

4. If there are more loads to put in vehicle, repeat the previous **LOADING VEHICLE** steps for each load. When loading is finished, use **STOWING PLATFORM** procedure in this manual.

LOWERING PLATFORM
FIG. 15-2

UNLOADING VEHICLE

LOWERING THE PLATFORM

Use inboard control switch to lower (**DOWN**) platform (**FIG. 16-1**). Release toggle switch when platform reaches the ground.

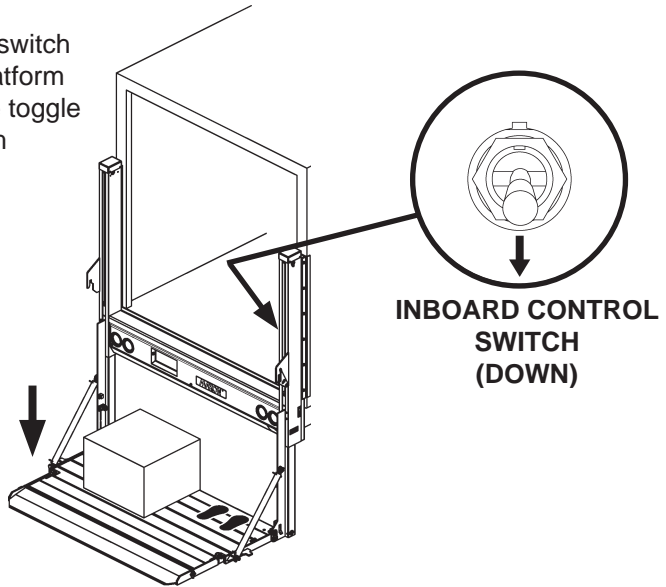

FIG. 16-1

RAISING THE PLATFORM

Use inboard control switch to raise (**UP**) platform (**FIG. 16-2**) from ground level to bed height. Release toggle switch when platform reaches bed height.

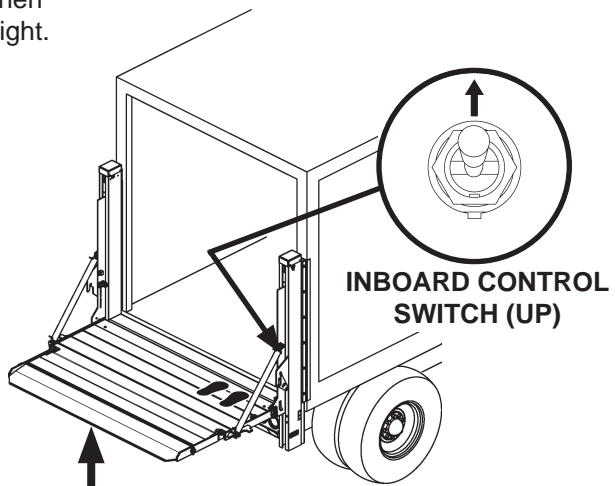

FIG. 16-2

UNLOADING VEHICLE - Continued

POSITIONING LOAD

WARNING

A load should never extend past the edges of the platform. Do not place unstable loads on platform and do not allow load to exceed lifting capacity of Liftgate. If standing on platform, do not allow your feet to extend beyond inboard edge of platform.

WARNING

Pulling the load from vehicle to platform can result in a fall from platform and serious injury. When unloading vehicle, always push the load out on the platform.

Load the platform at bed level (**FIG. 17-1**) as follows. Push load out of the vehicle to correct position on the platform. Place all loads as close as possible to the inboard edge of the platform with heaviest part toward the vehicle body as shown in **FIG. 17-1**. If standing on platform with the load, stand in the footprint area shown and comply with the **WARNING** at the top of this page.

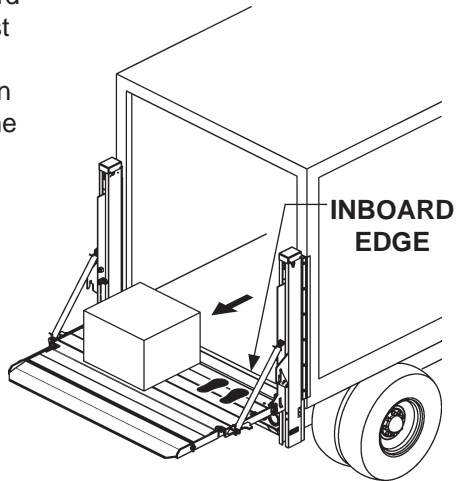

PUSHING LOAD ON PLATFORM
FIG. 17-1

LOWERING & UNLOADING PLATFORM

WARNING

Before lowering platform, make sure area surrounding platform is clear of people and objects. If standing on platform, do not allow your feet to extend beyond inboard edge of platform.

1. Use outboard control switch to lower (**DOWN**) platform to the ground (**FIG. 18-1**). Release toggle switch when platform reaches ground level.

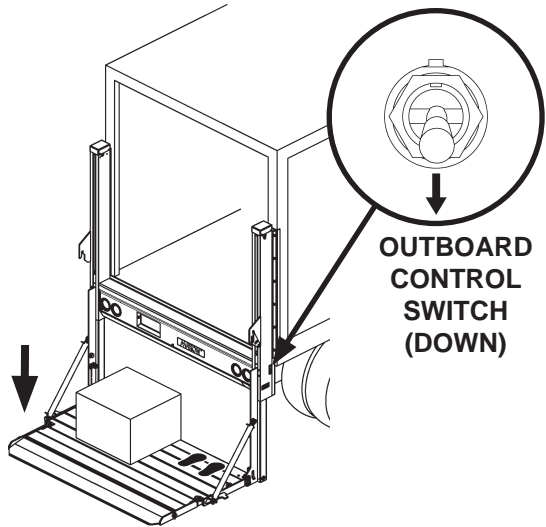

LOWERING PLATFORM TO GROUND LEVEL
FIG. 18-1

2. Carefully move load off platform (**FIG. 18-2**) and then move it to a place where it will not become a hazard for people and other vehicles. If there is more to unload from vehicle, repeat the previous **UNLOADING VEHICLE** steps for each load. When unloading is finished, use **STOWING PLATFORM** procedure in this manual.

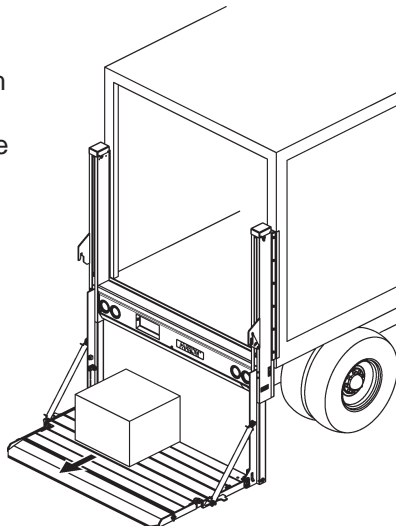

MOVING LOAD OFF PLATFORM
FIG. 18-2

STOWING PLATFORM

NOTE: Ensure platform is stowed under hydraulic pressure.

1. Use outboard control switch to raise (**UP**) platform to comfortable height (12" to 18") above ground level (**FIG. 19-1**).

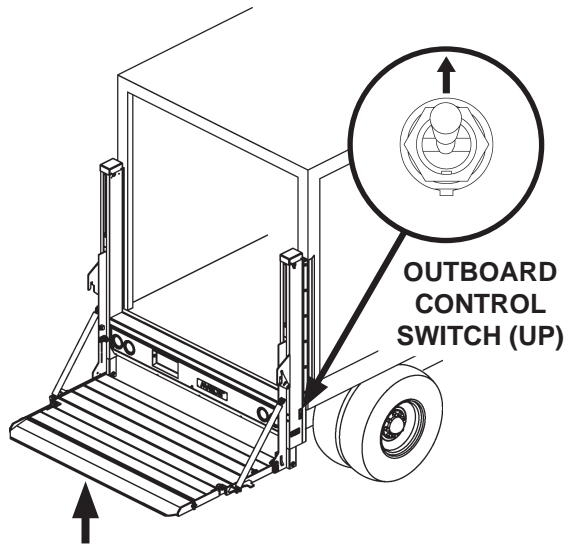

FIG. 19-1

2. Fold and lock flipover (if equipped) (**FIG. 19-2**).

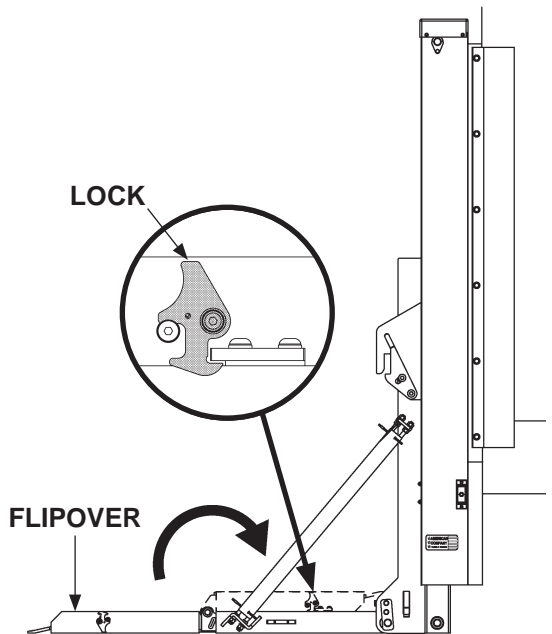
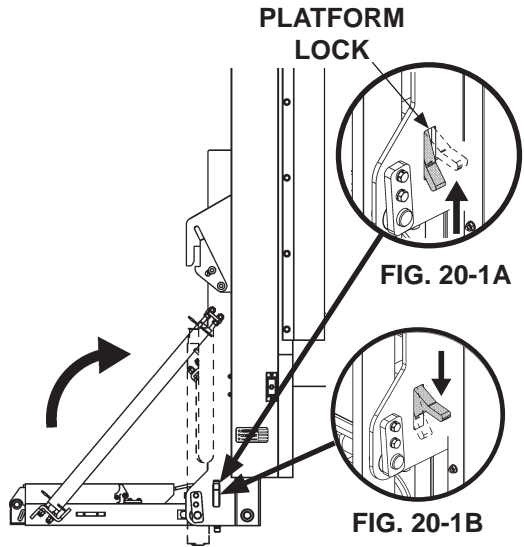

FIG. 19-2

STOWING PLATFORM - Continued

NOTE: If platform is equipped with hydraulic closer, do step 4.

3. Pull **UP** on platform lock (**FIG. 20-1A**) to unlock platform. Fold platform to stowed position (**FIG. 20-1**). Push platform lock **DOWN** to lock platform (**FIG. 20-1B**).



FOLDING PLATFORM
FIG. 20-1

CAUTION

Folding the platform with hydraulic closer requires 2 hands on the controls. This helps prevent injuries.

4. If equipped with hydraulic closer, (**FIG. 20-2**) use one hand for outboard control switch (**UP**) (**FIG. 20-2A**) and one hand for **FOLD/UNFOLD** switch (**FIG. 20-2B**). Activate **FOLD** and **UP** together until platform is folded.

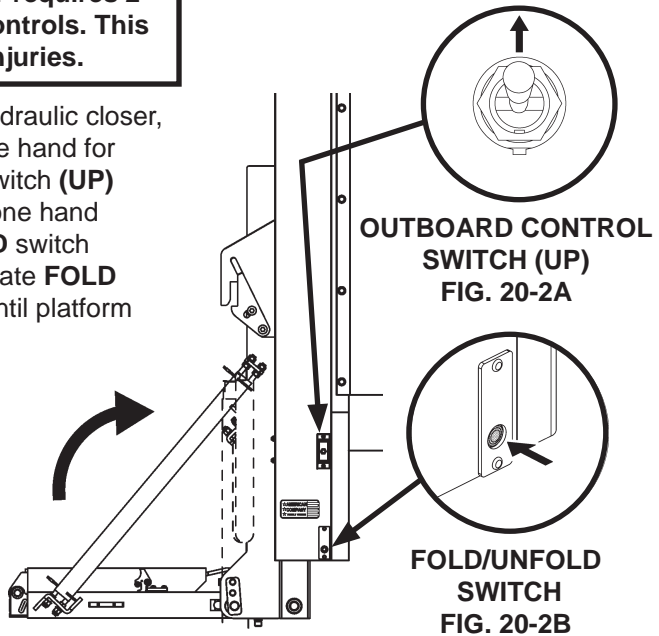

FOLDING PLATFORM WITH HYDRAULIC CLOSER
FIG. 20-2

5. Use outboard control switch to raise (UP) platform (FIG. 21-1) to clear transit hooks (FIG. 21-1A). Final platform resting position is shown in FIG. 21-1B.

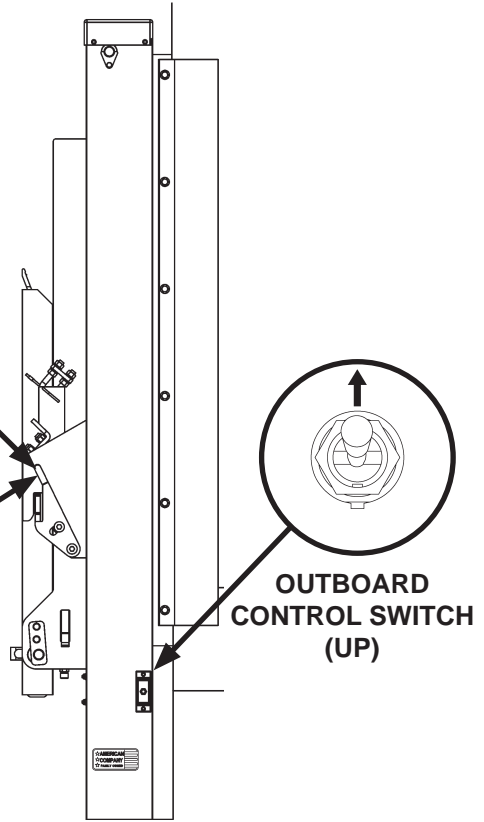
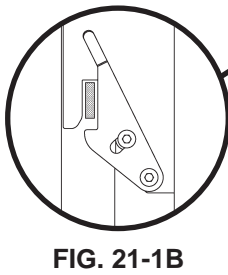
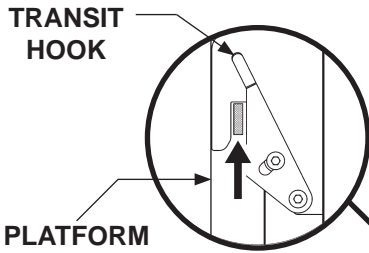

RAISE PLATFORM
FIG. 21-1

USING STANDARD CART STOPS (IF EQUIPPED)

CAUTION

To prevent injuries caused by tripping and falling, make sure cart stops are closed before walking on and off outboard end of platform.

NOTE: Some Liftgates are equipped with single or dual cart stops. Cart stops prevent loaded carts from rolling off outboard end of platform. Single cart stops are 1 section, about the same as overall width of platform, and operate with one set of controls. Dual cart stops are 2 identical sections, with a combined width about the same as overall width of platform, and each is independently operated with separate controls (1 set of controls per cart stop). The following procedure shows how to operate dual cart stops; however, a single cart stop operates the same way.

1. Load a platform with cart stops at ground level as follows. Make sure cart stops are closed when loading the platform (**FIGS. 22-1 and 22-2**). Then, move load on the platform as shown in **FIG. 22-1**.

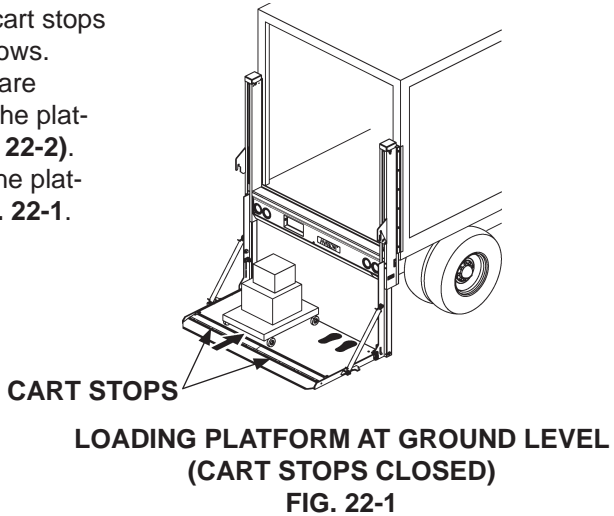

2. To close cart stops, push shoot bolt to position shown in **FIG. 22-2**. Step on cart stops and push down into locked position.

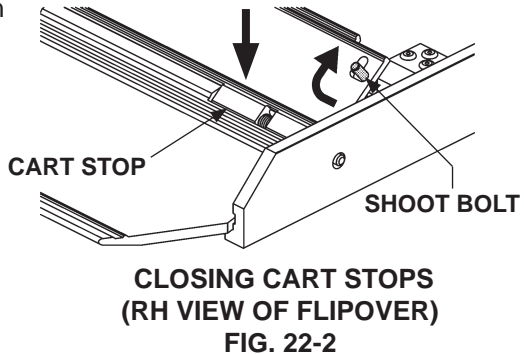

3. To open cart stops, push shoot bolt in direction shown in **FIG. 23-1**.

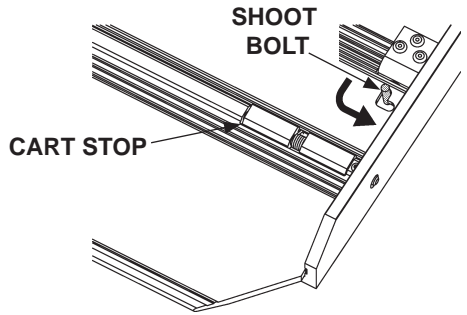

**OPENING CART STOPS
(RH VIEW OF FLIP OVER)
FIG. 23-1**

4. Open cart stops (**FIGS. 23-1 and 23-2**). Next, position cart and stand in the footprint area as shown in **FIG. 23-2**.

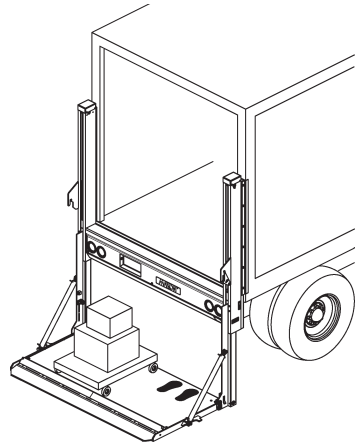

**CART STOPS OPEN
FIG. 23-2**

5. Raise the platform to bed level (**FIG. 25-3**). Move the load off the platform into the vehicle body (**FIG. 25-3**).

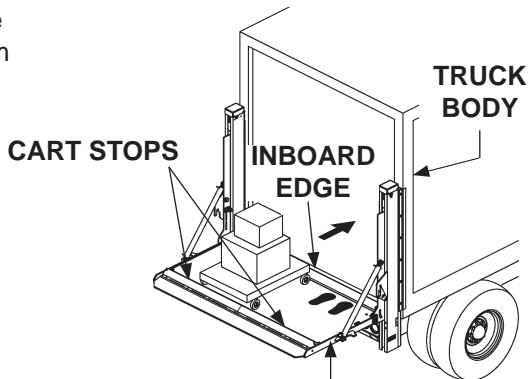

**PLATFORM
UNLOADING PLATFORM AT BED LEVEL
FIG. 23-3**

USING STANDARD CART STOPS (IF EQUIPPED)

- Continued

WARNING

Pulling the load from vehicle to platform can result in a fall from platform and serious injury. When unloading vehicle, always push the load out on the platform.

6. When loading the platform at bed level, make sure cart stops are open (FIG. 24-1). Push load out of the vehicle to correct position on the platform. Place all loads as close as possible to the inboard edge of the platform with heaviest part toward the truck body as shown in FIG. 24-1. If standing on platform with the load, stand in the footprint area shown and comply with the WARNING on page 19.

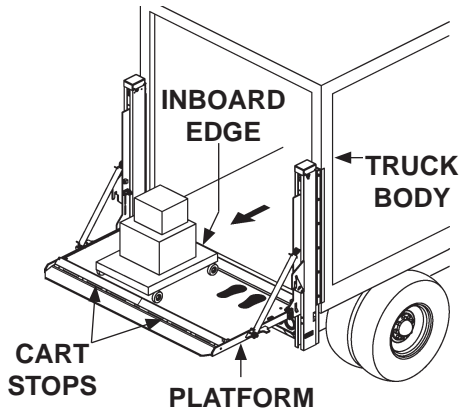

LOADING PLATFORM AT BED LEVEL
(DUAL CART STOPS OPEN)

FIG. 24-1

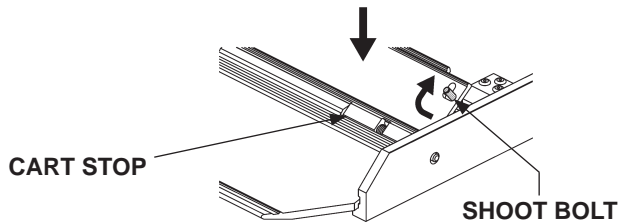

CLOSING CART STOPS
(RH VIEW OF FLIPOVER)

FIG. 24-2

7. Unload the platform with cart stops at ground level as follows. Make sure cart stops are closed when unloading the platform (FIG. 24-2). Move cart enough to close cart stop. Then, move load off the platform as shown in FIG. 24-3.

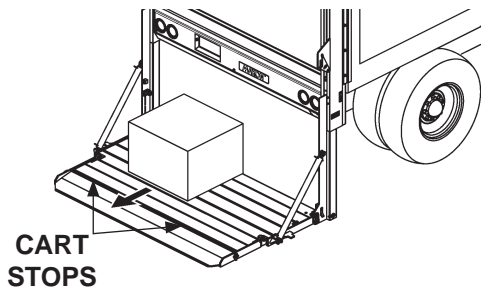

CART STOPS CLOSED

FIG. 24-3

USING RETENTION RAMP (IF EQUIPPED)

CAUTION

To prevent injuries caused by tripping and falling, make sure retention ramp is in the ramp position before walking on and off outboard end of platform.

NOTE: Some Liftgates are equipped with a retention ramp. A retention ramp, like a cart stop, prevents a load from rolling or sliding off outboard end of platform. Unlike a cart stop, a retention ramp lets you use the entire load surface of platform. The catches on top of the flipover and a cam-like hinge action keep retention ramp stowed when not in use. The cam-like hinge also allows the retention ramp to be rotated and locked in retention position or in ramp position. The following procedure shows how to operate a retention ramp.

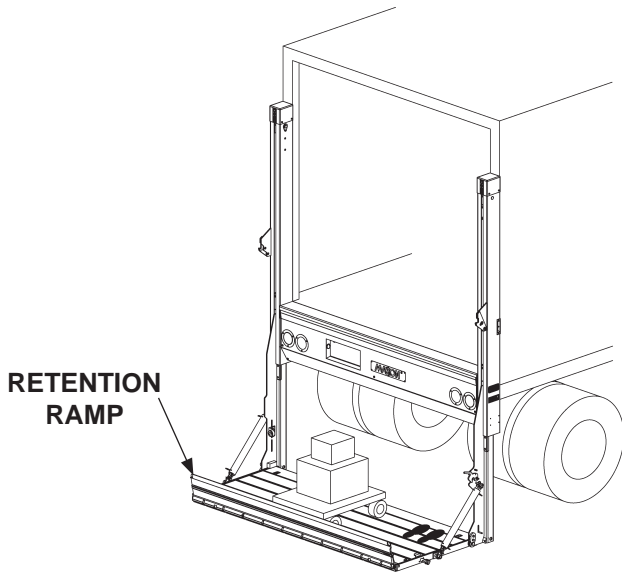

FIG. 25-1

USING RETENTION RAMP (IF EQUIPPED) - Continued

CAUTION

To prevent injuries, stay clear of the retention ramp path as it is moved to ramp position. Go to either side of the ramp and stay out of the way.

NOTE: To unhook the retention ramp, stand at the RH side of flipover. After the retention ramp is unhooked, the recommended place for handling the retention ramp is at the center of the free edge (**FIG. 26-2**).

1. Unhook retention ramp (**FIG. 26-1**). To release from the catches, pull retention ramp toward outboard end of flipover as shown in **FIG. 26-2**.

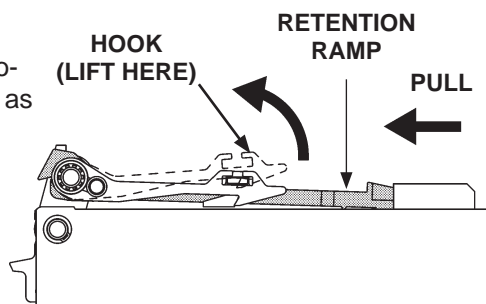

**UNHOOKING RETENTION RAMP
(RH VIEW OF FLIPOVER)
FIG. 26-1**

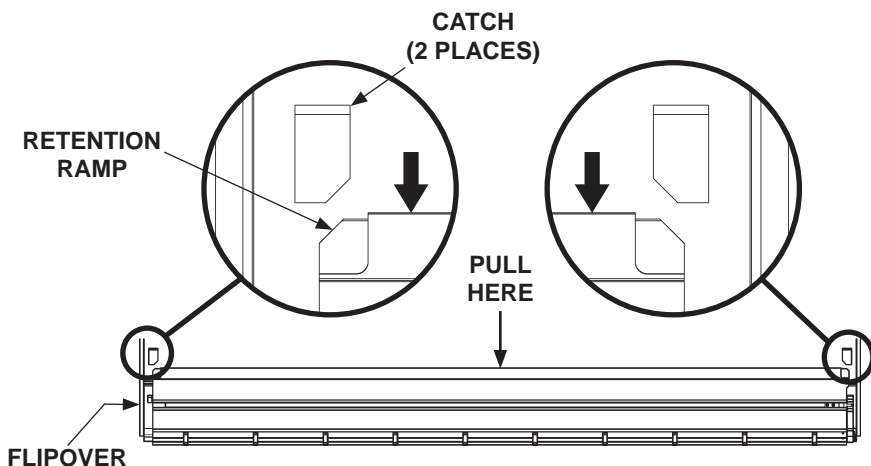

**RELEASING RETENTION RAMP
(TOP VIEW OF FLIPOVER)
FIG. 26-2**

! CAUTION

To prevent injuries, stay clear of the retention ramp path as it is moved to ramp position. Go to either side of the ramp and stay out of the way.

2. Continue to pull retention ramp to the retention position (FIG. 27-1) and then to ramp position (FIG. 27-2).

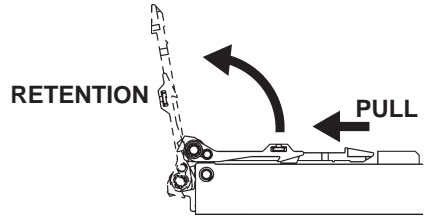

**MOVING TO RETENTION POSITION
(RH VIEW OF FLIP OVER)
FIG. 27-1**

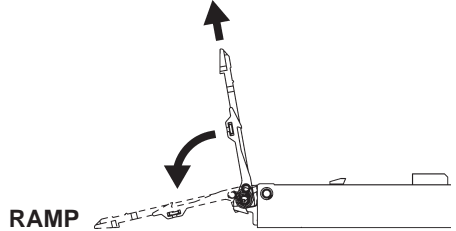

**MOVING TO RAMP POSITION
(RH VIEW OF FLIP OVER)
FIG. 27-2**

3. When cart is on platform, place the retention ramp in the retention position (FIGS. 27-3 and 27-4). Next, stand in the footprint area shown in FIG. 27-3.

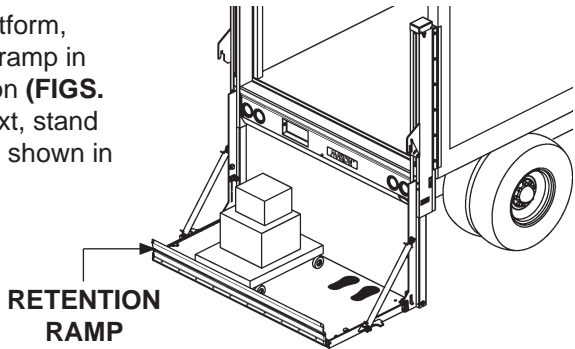

**RAMP IN RETENTION POSITION
FIG. 27-3**

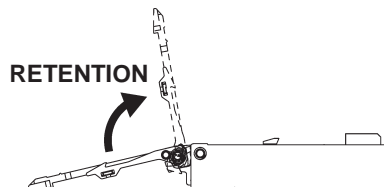

**ROTATING TO RETENTION POSITION
(RH VIEW OF FLIP OVER)
FIG. 27-4**

USING RETENTION RAMP (IF EQUIPPED) - Continued

WARNING

Pulling the load from vehicle to platform can result in a fall from platform and serious injury. When unloading vehicle, always push the load out on the platform.

4. When loading the platform at bed level, make sure retention ramp is in the retention position (**FIG. 30-1**). Push load out of the vehicle to correct position on the platform. Place all loads as close as possible to the inboard edge of the platform with heaviest part toward the truck body as shown in **FIG. 28-1**. If standing on platform with the load, stand in the footprint area shown and comply with the **WARNING** on page 19.

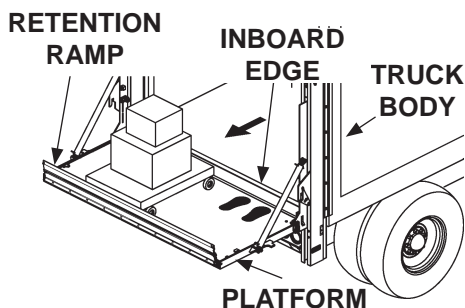

**LOADING PLATFORM AT BED LEVEL
(RAMP IN RETENTION POSITION)**

FIG. 28-1

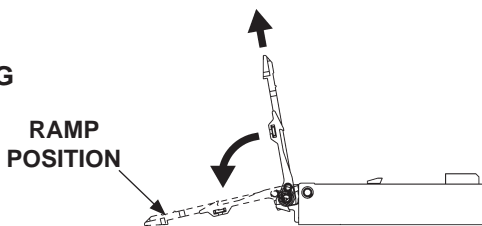

**ROTATING TO RAMP POSITION
(RH VIEW OF FLIPOVER)**

FIG. 28-2

5. Unload the platform with retention ramp at ground level as follows. Make sure retention ramp is in the ramp position when unloading the platform (**FIG. 28-2**). Move cart enough to reposition retention ramp. Then, move load off the platform as shown in **FIG. 28-3**.

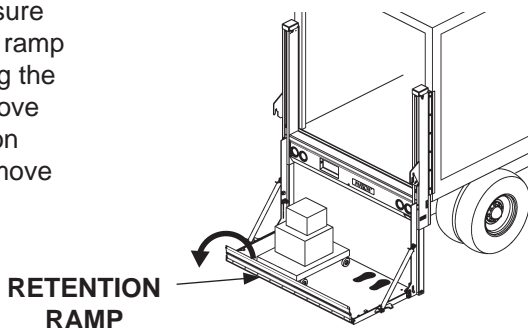

**UNLOADING PLATFORM AT GROUND LEVEL
(RAMP POSITION)**

FIG. 28-3

6. To stow, rotate retention ramp to retention position and then to the flat position on flipover as shown in FIG. 29-1.

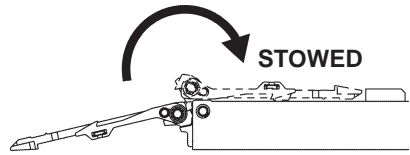

ROTATING RAMP TO STOWED POSITION (RH VIEW OF FLIPOVER)
FIG. 29-1

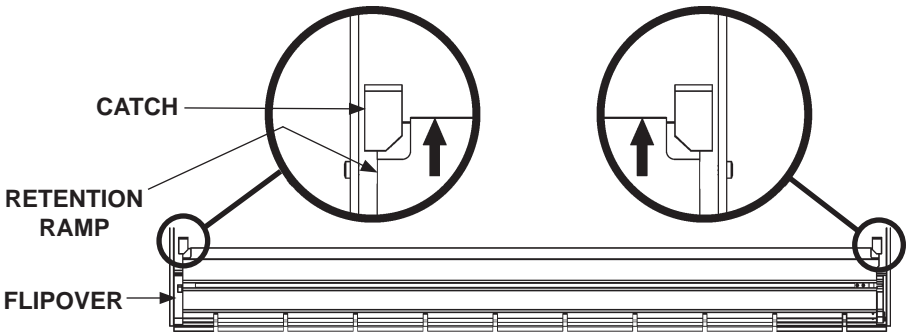

STOWING THE RAMP (TOP VIEW OF FLIPOVER)
FIG. 29-2

7. Push the retention ramp fully into the catches (FIG. 29-2). Make sure retention ramp is hooked to the flipover (FIG. 29-3).

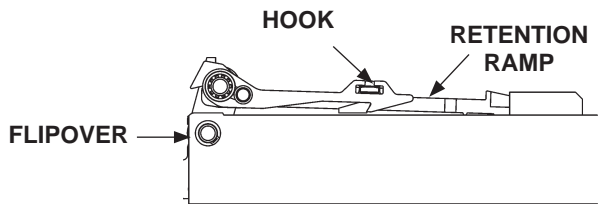

RAMP HOOKED TO FLIPOVER (RH VIEW OF FLIPOVER)
FIG. 29-3

