

M-16-33  
REV B  
SEPTEMBER 2017

# MAXON®

## TE-25

## TE-30

### INSTALLATION MANUAL

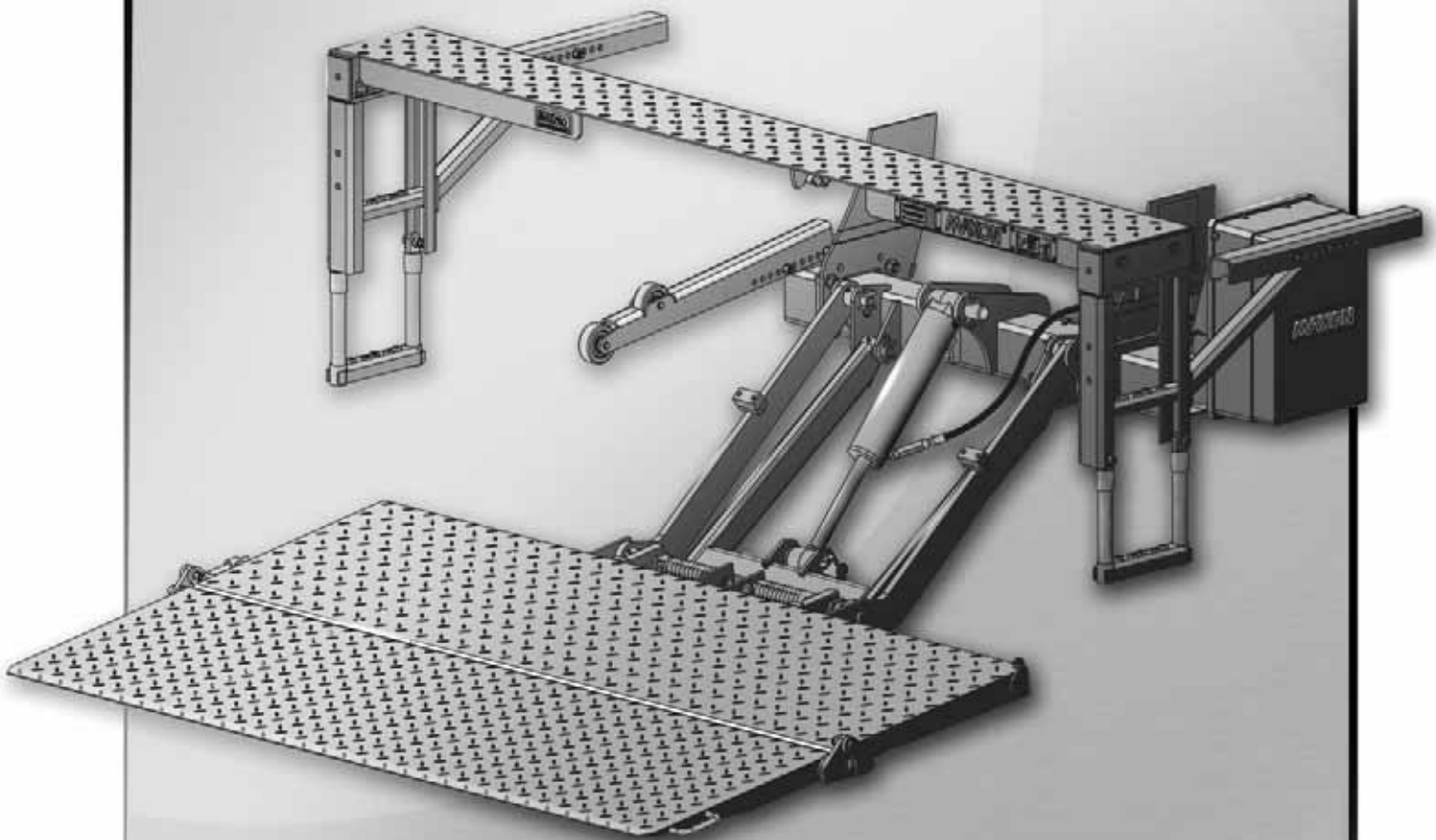

To find **maintenance & parts** information for your **TE-25 or TE-30 Liftgate**, go to [www.maxonlift.com](http://www.maxonlift.com). Click the **PRODUCTS, TUK-A-WAY and TE-25/TE-30** buttons. Open the **Maintenance Manual** in the **PRODUCT DOCUMENTATION** window. For parts, click on the **PARTS PORTAL, TUK-A-WAY & TE-25/TE-30** buttons.

# TABLE OF CONTENTS

<b>SUMMARY OF CHANGES: M-16-33, REVISION B</b> .....	4
<b>WARNINGS</b> .....	5
<b>SAFETY INSTRUCTIONS</b> .....	6
<b>NOTICE</b> .....	6
TE-SERIES LIFTGATE COMPONENTS.....	7
PARTS BOXES FOR TE-SERIES.....	8
MANUALS & DECALS KITS .....	9
<b>VEHICLE REQUIREMENTS</b> .....	10
<b>CENTER OF MASS</b> .....	13
STEP 1 - INSTALL EXTENSION PLATES .....	14
WELD EXTENSION PLATE TO VEHICLE.....	15
BOLT EXTENSION PLATE TO VEHICLE .....	16
WELD A BOLT-ON EXTENSION PLATE TO VEHICLE .....	19
BOLT INSTALLATION BRACKETS TO EXTENSION PLATE .....	20
STEP 2 - WELD LIFTGATE TO VEHICLE .....	21
STEP 3 - ATTACH OPTIONAL BATTERY BOX & FRAME TO VEHICLE (IF EQUIPPED) .	26
STEP 4 - RUN POWER CABLE.....	34
STEP 5 - CONNECT POWER CABLE.....	36
STEP 6 - CONNECT GROUND CABLE (RECOMMENDED).....	38
STEP 7 - INSTALL CONTROL SWITCH .....	39
STEP 8 - CHECKING HYDRAULIC OIL.....	42
STEP 9 - CONNECT POWER CABLE TO BATTERY.....	44
STEP 10 - REMOVE LOCKING ANGLE AND CHECK FOR INTERFERENCE.....	45
STEP 11 - BOLT PLATFORM OPENER TO LIFTGATE.....	49
STEP 12 - PLATFORM ADJUSTMENT (IF REQUIRED) .....	51

STEP 13 - FINISH WELDING LIFTGATE TO VEHICLE ..... 54

STEP 14 - ADJUST SAFETY HOOK (IF REQUIRED) ..... 55

STEP 15 - VEHICLE TAILLIGHT POSITIONING (IF REQUIRED)..... 56

**ATTACH DECALS ..... 57**

**TOUCHUP PAINTED OR GALVANIZED FINISH ..... 59**

**SYSTEM DIAGRAMS ..... 60**

PUMP, MOTOR & SOLENOID OPERATION - GRAVITY DOWN ..... 60

PUMP, MOTOR & SOLENOID OPERATION - POWER DOWN ..... 61

**HYDRAULIC SYSTEM DIAGRAMS ..... 62**

HYDRAULIC SCHEMATIC (GRAVITY DOWN)..... 62

HYDRAULIC SCHEMATIC (POWER DOWN) ..... 63

**ELECTRICAL SYSTEM DIAGRAMS ..... 64**

ELECTRICAL SCHEMATIC (GRAVITY DOWN) ..... 64

ELECTRICAL SCHEMATIC (POWER DOWN) ..... 65

TE-25/TE-30 ELECTRICAL VALUES ..... 66

**OPTIONS ..... 67**

OPTIONAL LIFTGATE COMPONENTS..... 67

## SUMMARY OF CHANGES: M-16-33, REVISION B

PAGE	DESCRIPTION OF CHANGE
8	Revised Installation Parts Box Tables A, B & C. Added new molded, toggle switch assembly, Added new 1/2" X 5/16" flat washer, 1-1/2" long self-tapping screws for control switch assembly, and 1/2" long self-tapping screws for rubber loom clamp. Added ground cable assembly, 2 GA X 38' LG.
11	Updated clearance dimensions for high bed and low bed installations.
14	Added weld-on and bolt-on extension plates with handles.
21	Revised Note for bolt-on (galvanized) and temporarily mounted (painted) mounting plates.
22, 23	Added illustrations and table showing mounting plates for various frame widths.
24	Added electrical welder Caution for connecting welder.
43	Combined EXXON & MOBIL oils on the same row with updated part numbers.
66	Added TE-25/TE-30 electrical values.
67, 68, 69	Updated hand-held, street side and dual control kits in the OPTIONS table. Removed cold galvanize spray (16 OZ) and bright zinc spray paint (16 OZ). Added painted step kit options.

**MAXON®** 11921 Slauson Ave. Santa Fe Springs, CA. 90670 (800) 227-4116 FAX (888) 771-7713

Comply with the following **WARNINGS** and **SAFETY INSTRUCTIONS** while installing Liftgates. See Operation Manual for operating safety requirements.

## **WARNING**

- Do not stand, or allow obstructions, under the platform when lowering the Liftgate. **Be sure your feet are clear of the Liftgate.**
- **Keep fingers, hands, arms, legs, and feet clear of moving Liftgate parts (and platform edges) when operating the Liftgate.**
- **Correctly stow platform when not in use. Extended platforms could create a hazard for people and vehicles passing by.**
- **Make sure vehicle battery power is disconnected** while installing Liftgate. Connect vehicle battery power to the Liftgate only when installation is complete or as required in the installation instructions.
- If it is necessary to stand on the platform while operating the Liftgate, keep your feet and any objects clear of the inboard edge of the platform. Your feet or objects on the platform can become trapped between the platform and the Liftgate extension plate.
- Never perform unauthorized modifications on the Liftgate. Modifications may result in early failure of the Liftgate and may create hazards for Liftgate operators and maintainers.
- Recommended practices for welding on steel parts are contained in the current **AWS (American Welding Society) D1.1 Structural Welding Code - Steel**. Damage to Liftgate and/or vehicle, and personal injury can result from welds that are done incorrectly.
- Recommended practices for welding galvanized steel are contained in the current **AWS (American Welding Society) D19.0 Welding Zinc-Coated Steel**. Damage to Liftgate and/or vehicle, and personal injury can result from welds that are done incorrectly.

## SAFETY INSTRUCTIONS

- Read and understand the instructions in this **Installation Manual** before installing Liftgate.
- Before operating the Liftgate, read and understand the operating instructions in **Operation Manual**.
- Comply with all **WARNING** and instruction decals attached to the Liftgate.
- Keep decals clean and legible. If decals are illegible or missing, replace them. Free replacement decals are available from **Maxon Customer Service**.
- Consider the safety and location of bystanders and location of nearby objects when operating the Liftgate. Stand to one side of the platform while operating the Liftgate.
- Do not allow untrained persons to operate the Liftgate.
- Wear appropriate safety equipment such as protective eyeglasses, faceshield and clothing while performing maintenance on the Liftgate and handling the battery. Debris from drilling and contact with battery acid may injure unprotected eyes and skin.
- Be careful working by an automotive type battery. Make sure the work area is well ventilated and there are no flames or sparks near the battery. Never lay objects on the battery that can short the terminals together. If battery acid gets in your eyes, immediately seek first aid. If acid gets on your skin, immediately wash it off with soap and water.
- If an emergency situation arises (vehicle or Liftgate) while operating the Liftgate, release the control switch to stop the Liftgate.
- A correctly installed Liftgate operates smoothly and reasonably quiet. The only noticeable noise during operation comes from the power unit while the platform is raised and lowered. Listen for scraping, grating and binding noises and correct the problem before continuing to operate Liftgate.

## NOTICE

- Maxon Lift is responsible for the instructions to correctly install **MAXON** Liftgates on trucks or trailers only.
- Liftgate installers, not Maxon Lift, are responsible for reviewing and complying with all applicable Federal, State, and Local regulations pertaining to the trailer or truck.
- Installers of the liftgate should ensure that all trucks and trailers are equipped with grab handles as needed. Refer to Technology Maintenance Council (TMC) RP 1428: Entry And Egress Guidelines for Vehicles With Fold-Under Type Liftgates.

# TE-SERIES LIFTGATE COMPONENTS

## ⚠ CAUTION

Prevent injuries and equipment damage. Before cutting the shipping straps from the Liftgate, put Liftgate on level ground that will support at least 1500 pounds. Be careful lifting and moving components (such as extension plate) after shipping straps are removed.

**NOTE:** Make sure you have all components and parts before you start installing Liftgate. Compare parts in the part box and each kit box with packing list closed in each box. If parts and components are missing or incorrect, call:

**Maxon Customer Service**

**Call (800) 227-4116 or**

**Send e-mail to [customersupport@maxonlift.com](mailto:customersupport@maxonlift.com)**

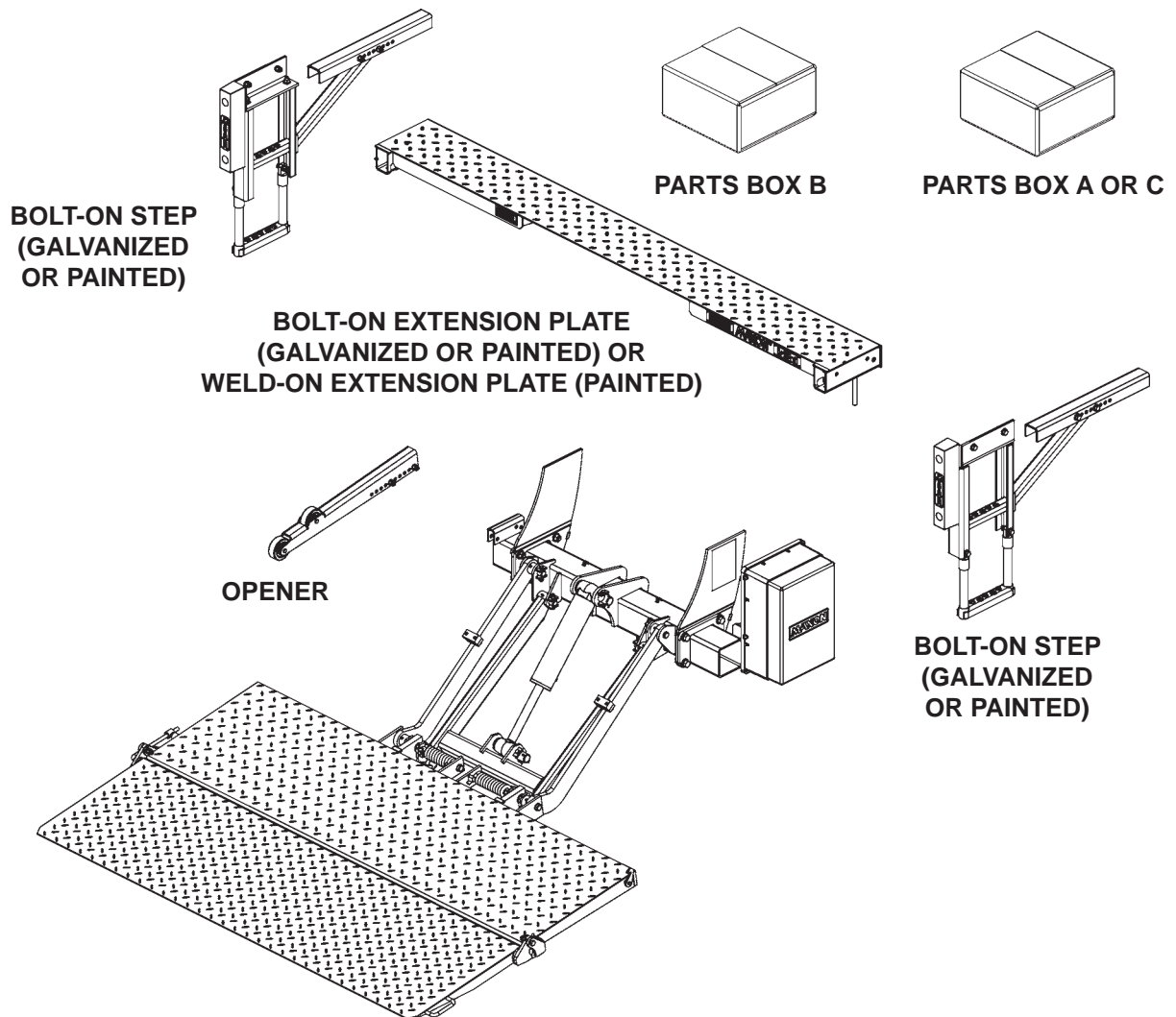

**LIFTGATE COMPONENTS**

**FIG. 7-1**

# PARTS BOXES FOR TE-SERIES

ITEM	NOMENCLATURE OR DESCRIPTION	QTY.	PART NUMBER
REF	PARTS BOX A	1	297502-01
1	SPRING CLIP	10	050079
2	PLASTIC TIE	2	206864
3	#10 LOOM CLAMP	2	801681
4	SCREW TAPPING #10 X 1/2" LG.	2	030458
5	CABLE ASSEMBLY, 2GA, 48" LG.	1	251871-26

**CONTENTS OF PARTS BOX A  
TABLE 8-1**

ITEM	DESCRIPTION	QTY.	PART NUMBER
REF	PARTS BOX B	1	297049-01
1	TOGGLE SWITCH ASSEMBLY	1	296855-01
2	FLAT WASHER	2	902000-13
3	HEX NUT, 1/2"-13	2	901011-9
4	HEX HEAD CAP SCREW, 1/2"-13 X 1-1/2" LG.	2	900035-3
5	INSTALLATION BRACKET	2	269462-01
6	SCREW, SELF TAPPING, #10-24 X 1-1/2" LG	2	900057-7
7	LUG, 2GA COPPER	1	906497-02

**CONTENTS OF PARTS BOX B  
TABLE 8-2**

ITEM	NOMENCLATURE OR DESCRIPTION	QTY.	PART NUMBER
REF	PARTS BOX C	1	297502-02
1	SPRING CLIP	20	050079
2	PLASTIC TIE	4	206864
3	GROMMET, 1" DIA, 2 HOLES	1	266428-09
4	CABLE ASSY, 175 AMP 38' LG	1	264422
5	GROUND CABLE ASSY, 2 GA X 38' LG	1	269191-01
6	SCREW TAPPING #10 X 1/2" LG.	2	030458
7	#10 LOOM CLAMP	2	801681

**CONTENTS OF PARTS BOX C  
TABLE 8-3**

**MAXON**<sup>®</sup> 11921 Slauson Ave. Santa Fe Springs, CA. 90670 (800) 227-4116 FAX (888) 771-7713



## MANUALS & DECALS KITS

To find **maintenance & parts** information for your **TE-25** or **TE-30 Liftgate**, go to **www.maxonlift.com**. Click the **PRODUCTS, TUK-A-WAY** and **TE-25/TE-30** button. Open the **Maintenance Manual** in the **PRODUCT DOCUMENTATION** window. For parts, click on the **PARTS PORTAL, TUK-A-WAY & TE-25/TE-30** buttons.

ITEM	QTY.	PART NO.	DESCRIPTION
REF.	1	297048-03	KIT, MANUAL & DECAL TE-25
1	1	220382	DECAL, 2500# CAPACITY
2	1	285800-01	DECAL, OPERATING INSTRUCTIONS
3	1	265736-03	DECAL, PINCH HAZARD WARNING
4	1	282522-01	DECAL, SHEET, SMALL WARNING & CAUTION
5	1	282847-02	DECAL, WARNING, STOW
6	1	M-16-33	MANUAL, TE-25/TE-30 INSTALLATION
7	1	M-16-34	MANUAL, TE-25/TE-30 OPERATION

**TABLE 9-1**

ITEM	QTY.	PART NO.	DESCRIPTION
REF.	1	297048-04	KIT, MANUAL & DECAL TE-30
1	1	220388	DECAL, 3000# CAPACITY
2	1	285800-01	DECAL, OPERATING INSTRUCTIONS
3	1	265736-03	DECAL, PINCH HAZARD WARNING
4	1	282522-01	DECAL, SHEET, SMALL WARNING & CAUTION
5	1	282847-02	DECAL, WARNING, STOW
6	1	M-16-33	MANUAL, TE-25/TE-30 INSTALLATION
7	1	M-16-34	MANUAL, TE-25/TE-30 OPERATION

**TABLE 9-2**

# VEHICLE REQUIREMENTS

**NOTE:** The maximum (unloaded) operating vehicle body bed height for the **TE-25 & TE-30** high bed Liftgates is 54" and 42" minimum (loaded). The maximum (unloaded) operating vehicle body bed height for the **TE-25 & TE-30** low bed Liftgates is 44" and 36" minimum (loaded). Do not install this Liftgate on vehicle bodies equipped with swing open doors.

**NOTE:** Dimensions are provided as reference for fitting Liftgate to vehicle body.

**NOTE:** Measure the width of the Liftgate and the width of the vehicle body before you start doing this procedure. Ensure the Liftgate is the correct width for vehicle.

**NOTE:** Make sure vehicle is parked on level ground while preparing vehicle and installing Liftgate.

- See **TE-25 and TE-30 high bed installation dimensions** in **FIG. 11-1**.
- See **TE-25 and TE-30 low bed installation dimensions** in **FIG. 11-2**.
- See **TE-25 and TE-30 high bed truck frame cut-out dimensions** in **FIG. 12-1**.
- See **TE-25 and TE-30 low bed truck frame cut-out dimensions** in **FIG. 12-2**.

# VEHICLE REQUIREMENTS - Continued

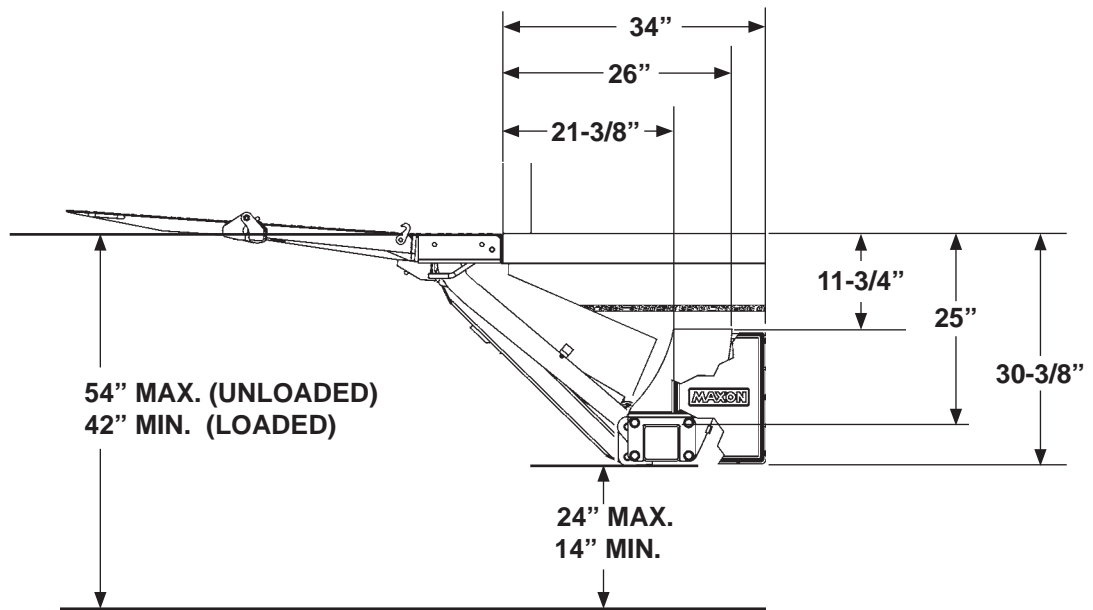

**CLEARANCES FOR TE-25 & TE-30 HIGH BED INSTALLATION  
FIG. 11-1**

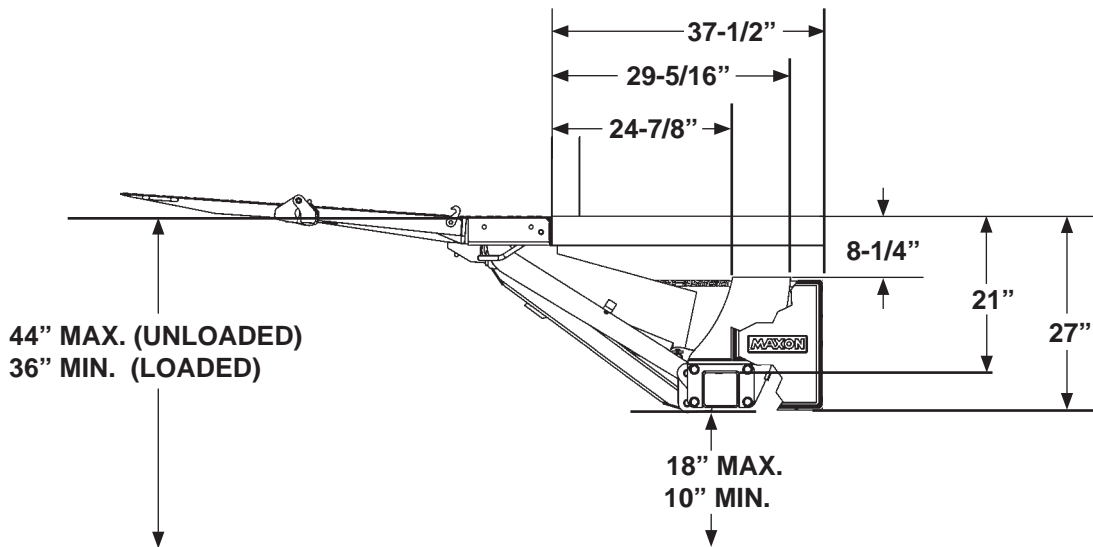

**CLEARANCES FOR TE-25 & TE-30 LOW BED INSTALLATION  
FIG. 11-2**

# VEHICLE REQUIREMENTS - Continued

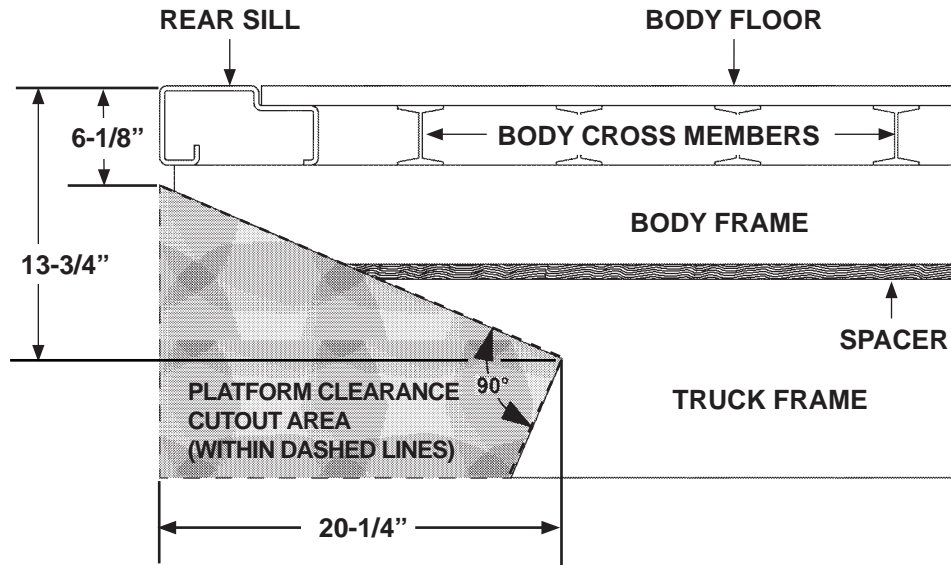

**VEHICLE FRAME CUT-OUT (42" TO 54" BED HEIGHTS)  
FIG. 12-1**

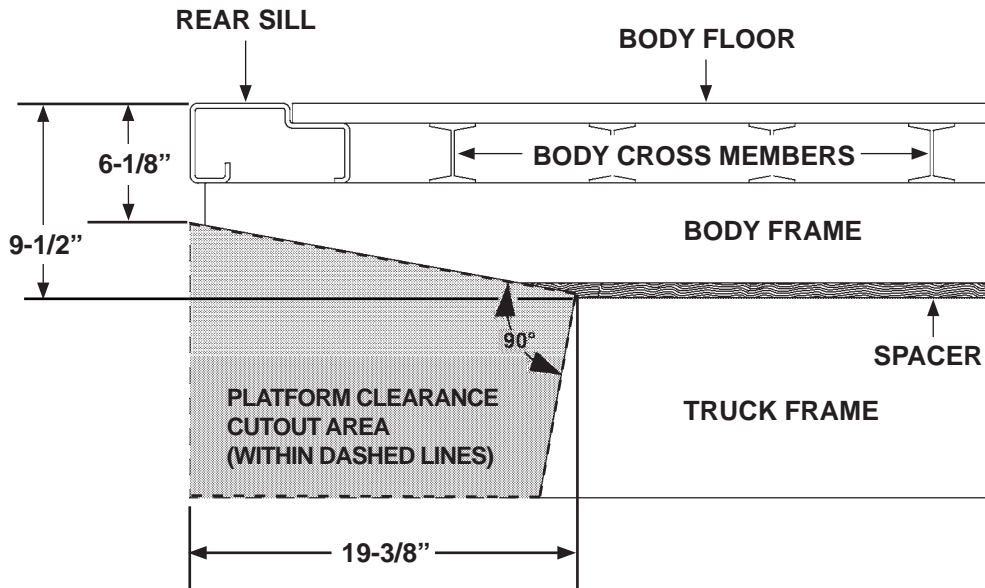

**VEHICLE FRAME CUT-OUT (36" TO 44" BED HEIGHTS)  
FIG. 12-2**

# CENTER OF MASS

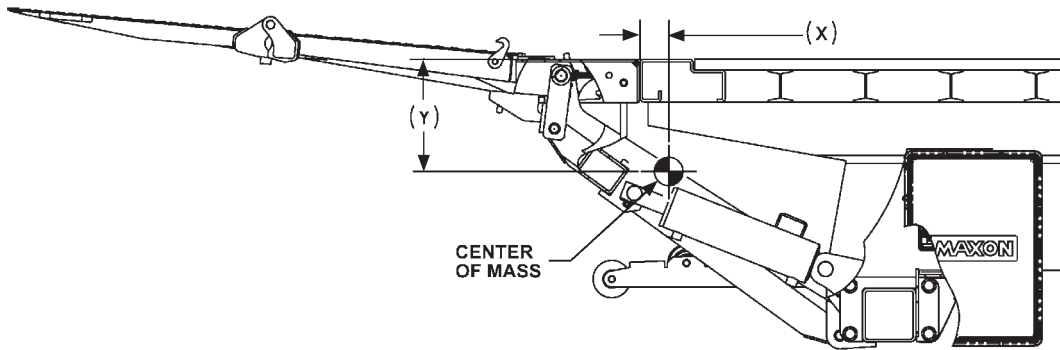

**TE-25/TE-30 CENTER OF MASS  
(PLATFORM AT BED HEIGHT)  
FIG. 13-1**

MODEL	PLATFORM	X	Y	X	Y
		(PLATFORM UNFOLDED)	(PLATFORM UNFOLDED)	(PLATFORM STOWED)	(PLATFORM STOWED)
TE-25/TE-30	22"+14" STEEL	5-5/8"	9-1/4"	5-3/4"	14-1/4"
	24"+24" STEEL	9-3/8"	8-1/2"	5-5/8"	13-7/8"
	24"+24" STEEL & ALUM	8"	9.1"	5-3/4"	14"
	24"+24" ALUM	6-9/16"	9-5/8"	5-3/8"	13-5/8"
	26"+26" STEEL & ALUM	9-1/2"	9-9/16"	6"	14.1"
	26"+26" ALUM	8-3/16"	9-3/8"	5-5/8"	13-7/8"
		TOLERANCE= +/- 3/16"			

**CENTER OF MASS DIMENSIONS  
(TE-25/TE-30 HIGH BED & LOW BED)  
TABLE 13-1**

## STEP 1 - INSTALL EXTENSION PLATES

**NOTE: TE-25 & TE-30** Liftgates may be equipped with two types of extensions plates. The **weld-on extension plate is shown in FIG. 14-1**. The bolt-on extension plate (**FIG. 14-2**) has bolt holes so it can be bolted to vehicle body. **GRADE 8** bolts are required. **MAXON** recommends getting the optional extension plate hardware kit listed in **OPTIONS** section. It also has holes for bolt-on steps and installation brackets, provided with components for installation. Refer to the following instructions for installing extension plates.

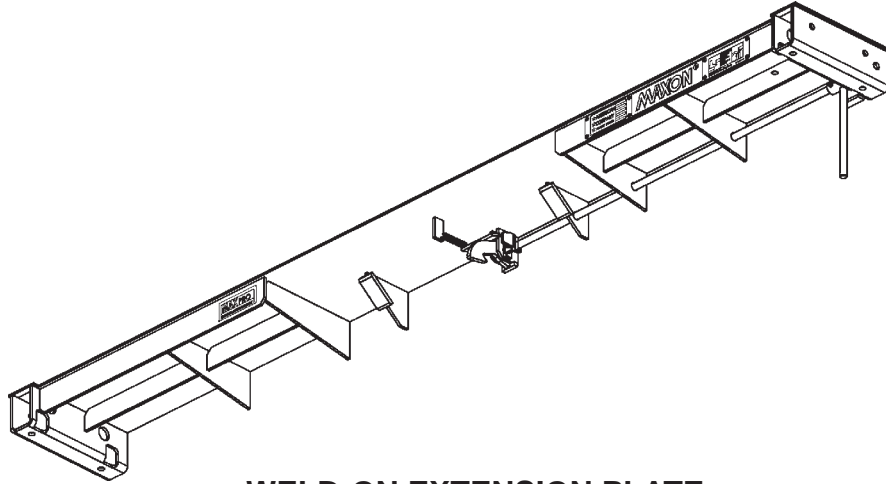

**WELD-ON EXTENSION PLATE**  
**FIG. 14-1**

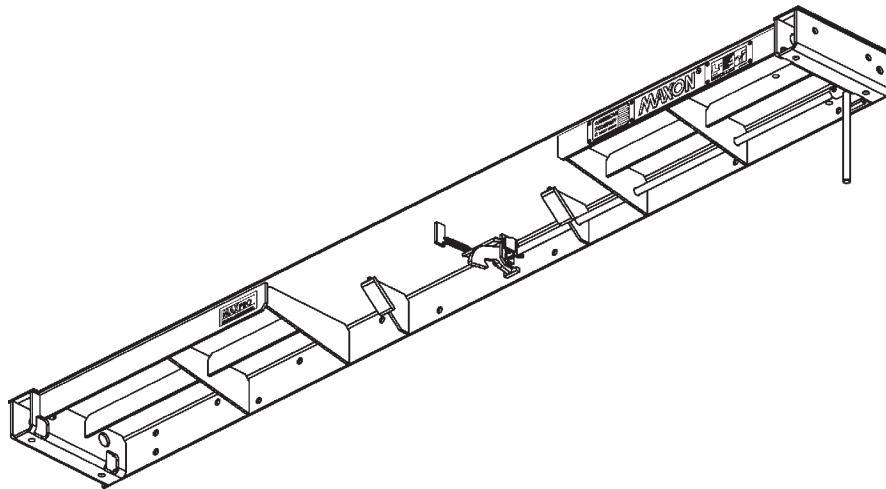

**BOLT-ON EXTENSION PLATE**  
**FIG. 14-2**

# STEP 1 - INSTALL EXTENSION PLATES - Continued

## WELD EXTENSION PLATE TO VEHICLE

### CAUTION

To protect the original paint system, a 3" wide area of paint must be removed from all sides of the weld area before welding.

**NOTE:** Before welding extension plate to vehicle body, make sure:

- Inboard edge of extension plate is flush with the top of sill on vehicle body.
- Top surface of extension plate is level with the ground.

Center the extension plate on vehicle body.  
Weld the extension plate to vehicle body rear sill as shown in **FIGS. 15-1 and 15-2.**

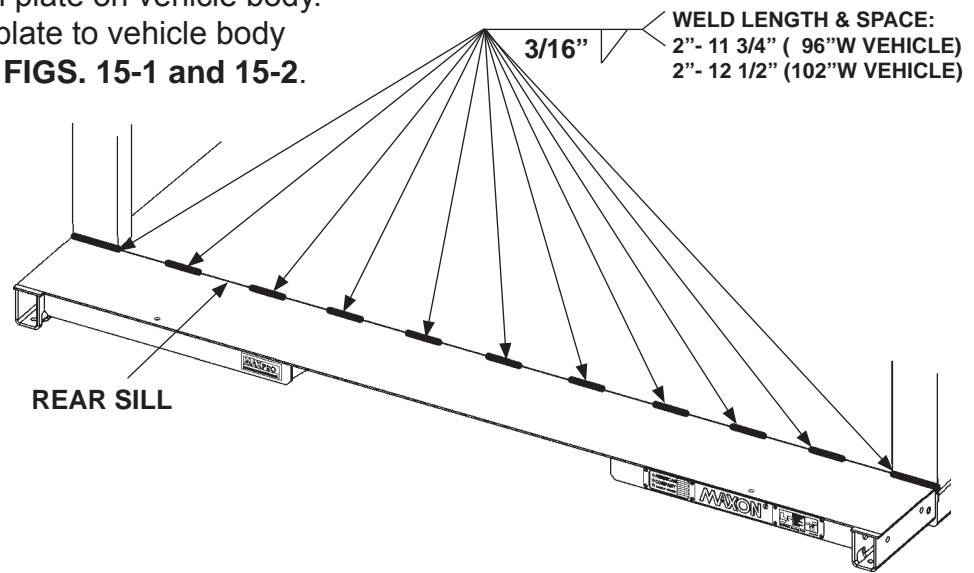

**EXTENSION PLATE WELDS - VIEWED FROM ABOVE**  
**FIG. 15-1**

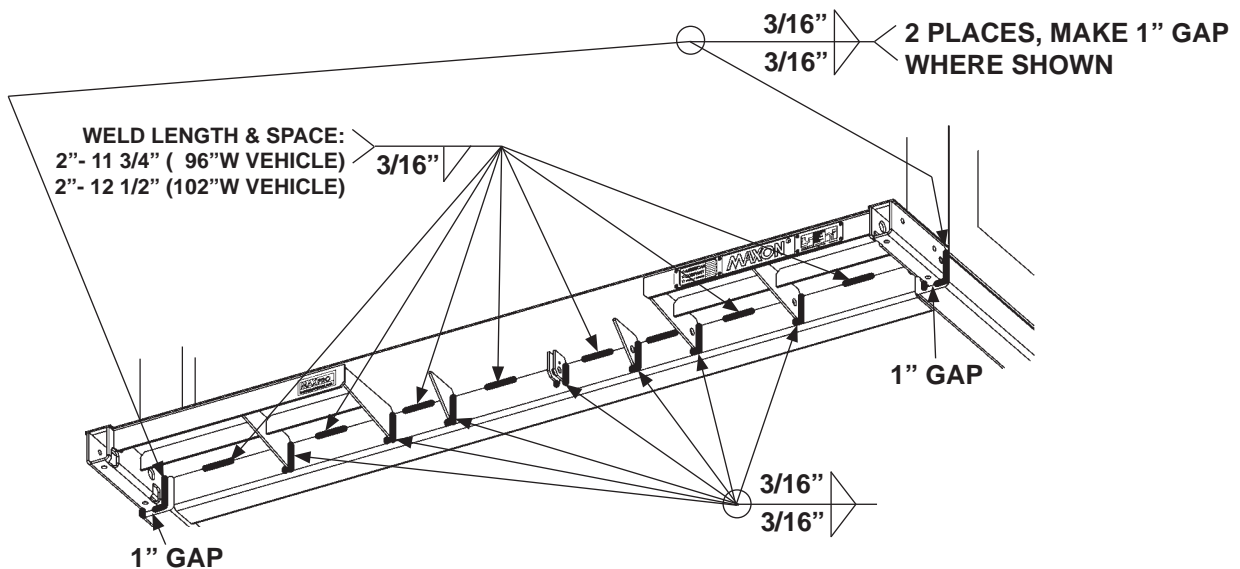

**EXTENSION PLATE WELDS - VIEWED FROM UNDERNEATH**  
**FIG. 15-2**

# STEP 1 - INSTALL EXTENSION PLATES - Continued

## BOLT EXTENSION PLATE TO VEHICLE

### CAUTION

To preserve the corrosion resistance properties of the galvanized finish, **MAXON** recommends bolting the extension plate to vehicle.

**NOTE:** The extension plate has bolt holes so it can be bolted to vehicle body. **Grade 8** bolts are required. **MAXON** recommends getting the optional extension plate hardware kit listed in **OPTIONS** section. Vehicle body must be drilled according to instructions. If necessary, extension plate may also be welded to vehicle body. Do the following bolting or welding instructions.

1. Mark and drill holes into rear sill as shown in **FIGS. 16-1 and 17-1**.

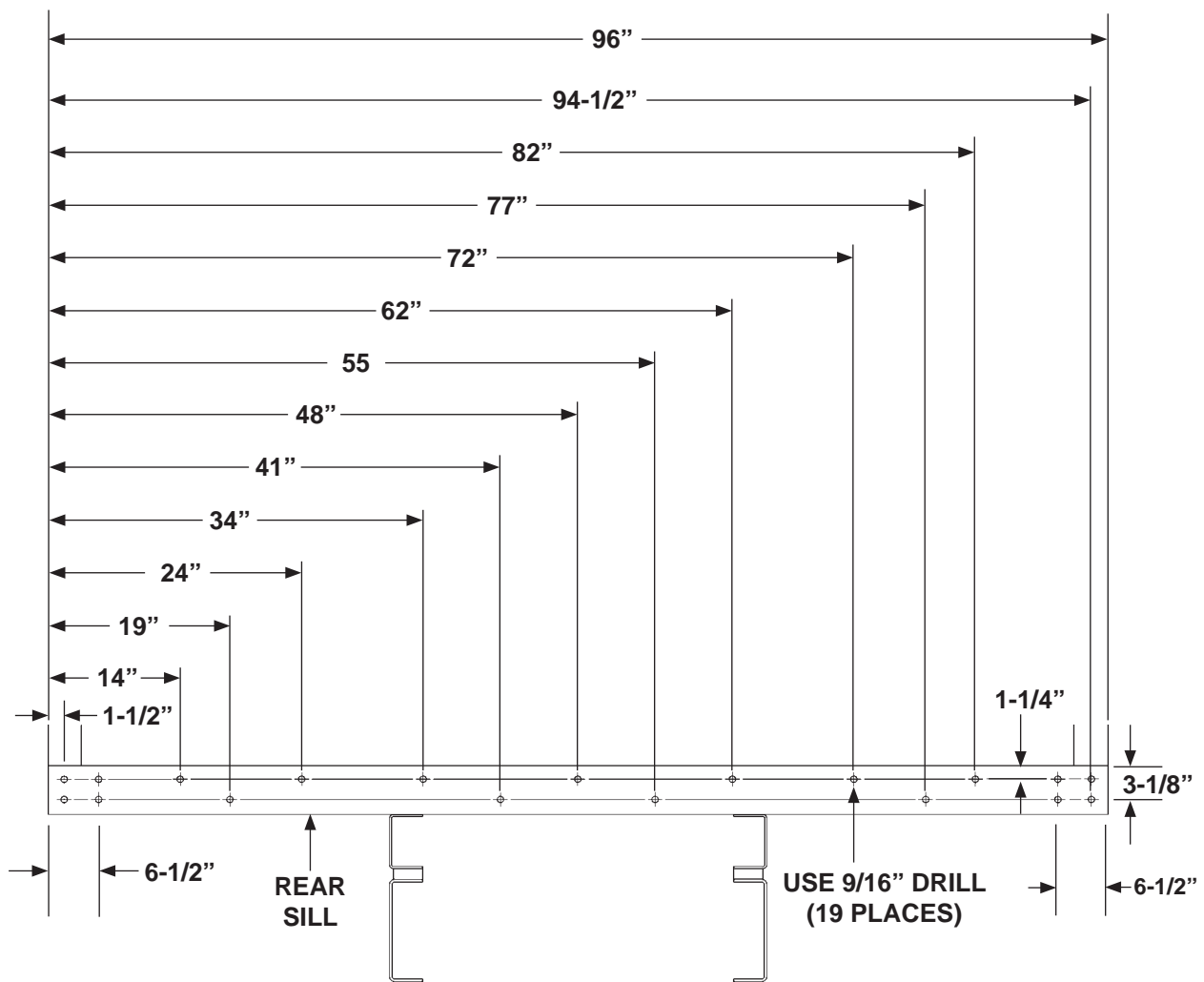

**REAR SILL - HOLE LOCATIONS FOR 96" WIDE VEHICLE**  
**FIG. 16-1**



# STEP 1 - INSTALL EXTENSION PLATES - Continued

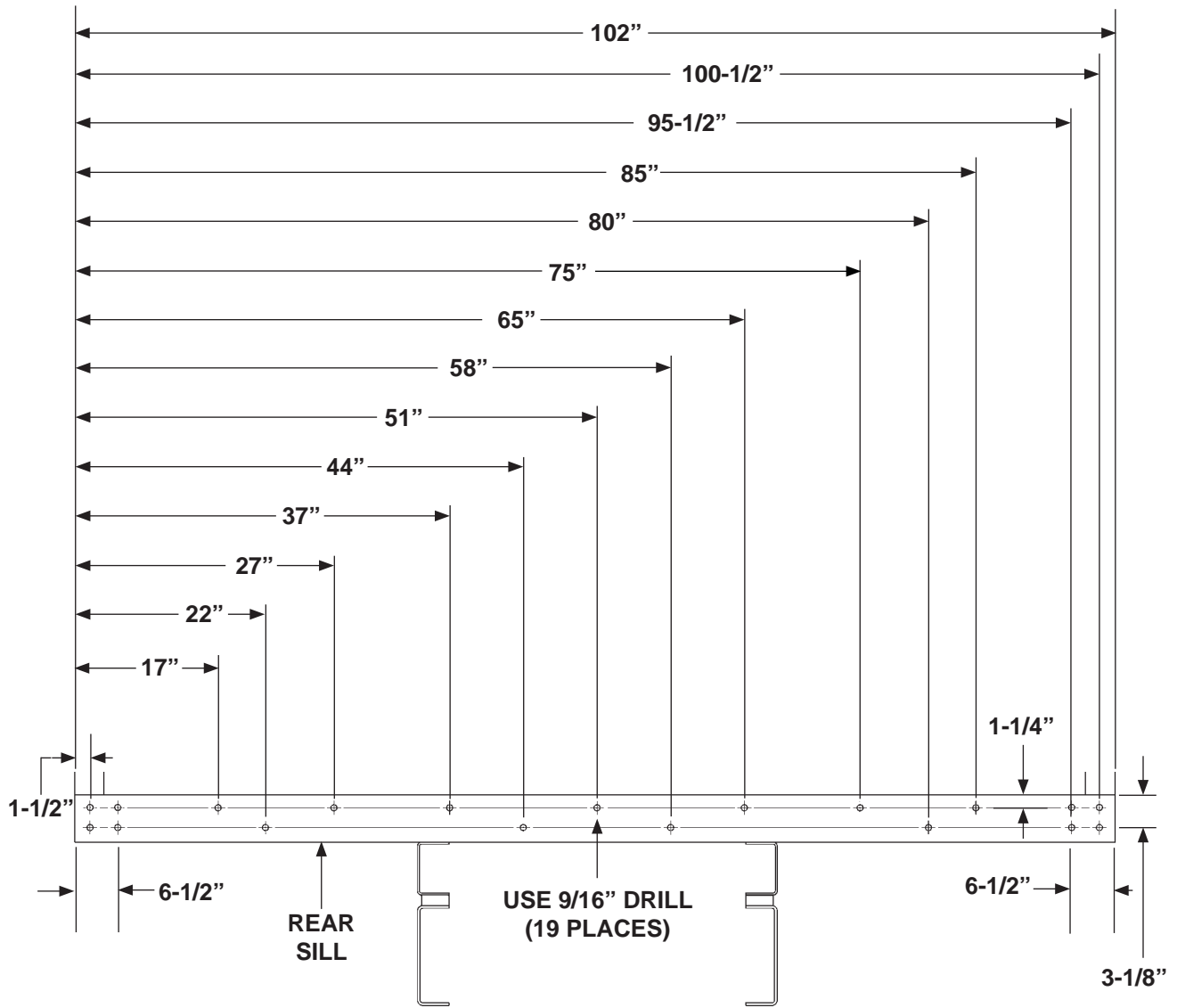

REAR SILL - HOLE LOCATIONS FOR 102" WIDE VEHICLE  
FIG. 17-1

MAXON® 11921 Slauson Ave. Santa Fe Springs, CA. 90670 (800) 227-4116 FAX (888) 771-7713

# STEP 1 - INSTALL EXTENSION PLATES - Continued

## CAUTION

The mating surface between the bolt-on extension plate and vehicle rear sill must be as flat as possible. Interference between the mating surfaces could result in a distorted top surface of extension plate when all the bolts are tightened. Distorted extension plate can also make the dual steps difficult to install correctly. Remove interference or shim rear sill to eliminate or reduce the possibility of a distorted extension plate.

**NOTE:** Do not tighten extension plate bolts and lock nuts until:

- All the bolts and lock nuts are in place.
- Mating surfaces of extension plate and rear sill are made flat as possible.
- Top of extension plate is flush with top of rear sill.

**NOTE:** Weld the LH and RH ends of the extension plate to vehicle body as shown in **FIG. 18-1** if any of the following conditions apply.

- Bolt holes are not accessible on the corner posts of the vehicle body.
- Liftgate will be used for dock loading applications.
- As required by body/trailer manufacturer

2. Bolt extension plate to vehicle as shown in **FIG. 18-1**. If necessary, reposition extension plate so top surface is flush with top surface of sill. Then, torque bolts and lock nuts to **105 +/-20 lb.-ft.**

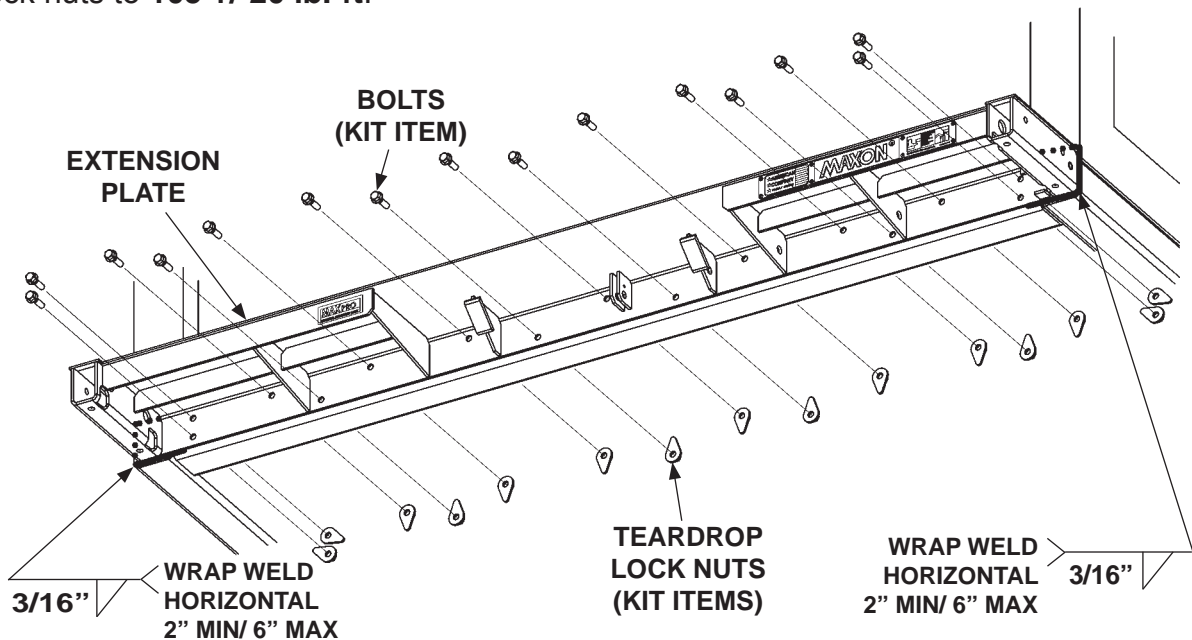

**BOLTING EXTENSION PLATE (96" WIDE EXTENSION PLATE SHOWN)  
FIG. 18-1**

**NOTE:** An optional 102" wide extension kit is available for 102" wide vehicles.

# STEP 1 - INSTALL EXTENSION PLATES - Continued

## WELD A BOLT-ON EXTENSION PLATE TO VEHICLE

### CAUTION

To preserve the corrosion resistance properties of the galvanized finish, MAXON recommends bolting the galvanized extension plate to vehicle.

Center the extension plate on vehicle body. Before welding extension plate to vehicle body, make sure top surface of extension plate is flush with floor of vehicle body. Weld the extension plate to vehicle body sill as shown in **FIGS. 19-1 and 19-2**.

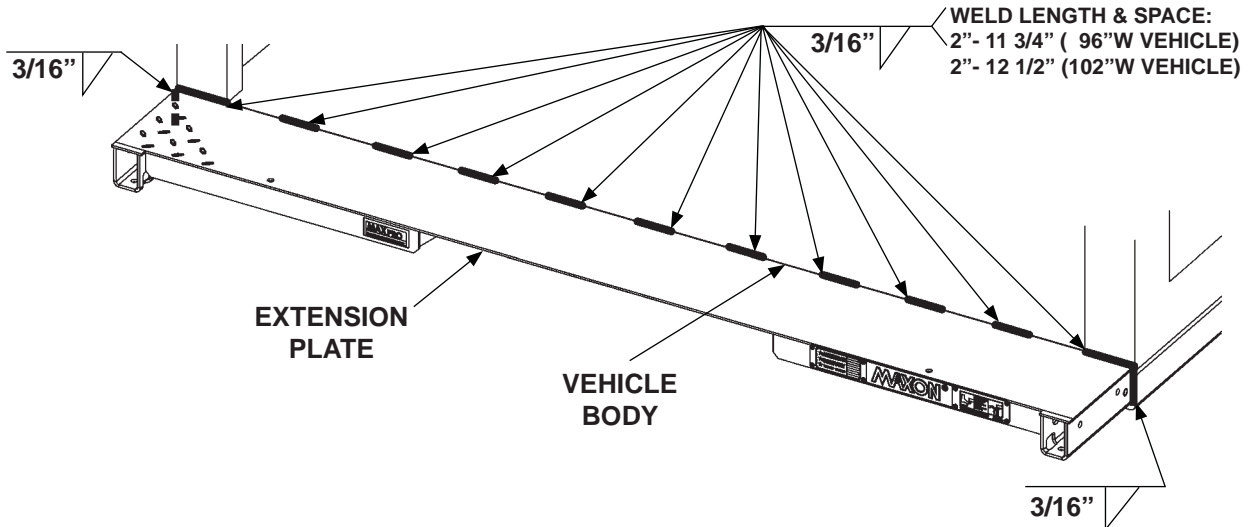

**EXTENSION PLATE WELDS - VIEWED FROM ABOVE**  
**FIG. 19-1**

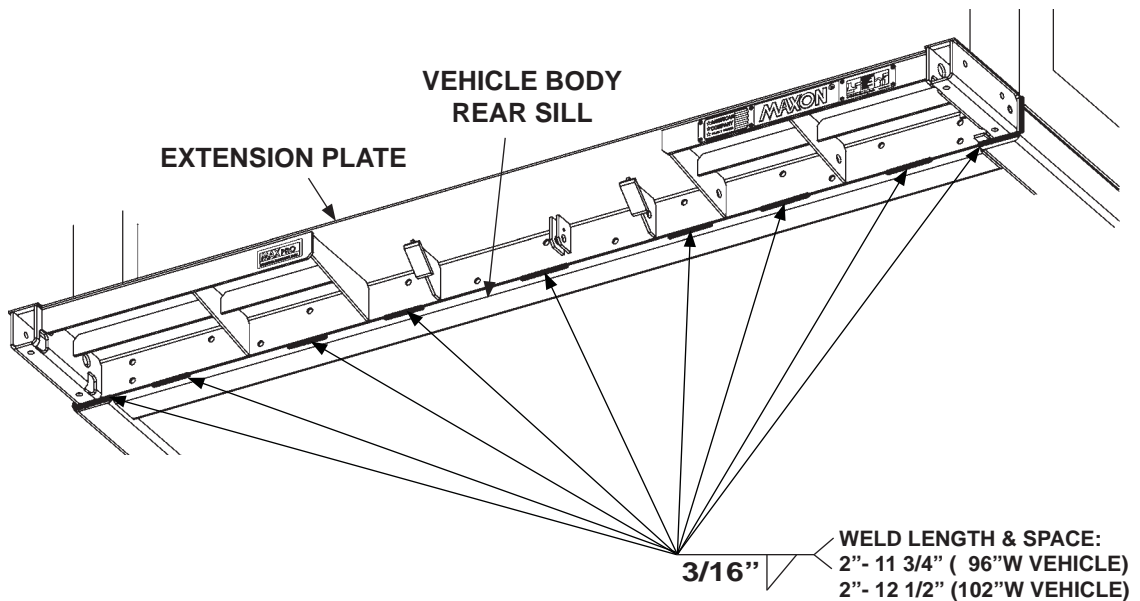

**EXTENSION PLATE WELDS - VIEWED FROM UNDERNEATH**  
**FIG. 19-2**

## STEP 1 - INSTALL EXTENSION PLATES - Continued BOLT INSTALLATION BRACKETS TO EXTENSION PLATE

**NOTE:** During installation of liftgate, installation brackets keep the heel of the platform level with extension plate and maintain a  $\frac{3}{4}$ " gap between extension plate and heel of platform. The extension plate has bolt holes for bolting on the installation brackets provided in parts box.

Bolt 2 installation brackets (parts box items) on the extension plate as shown in **FIG. 20-1**. Tighten hex nuts securely.

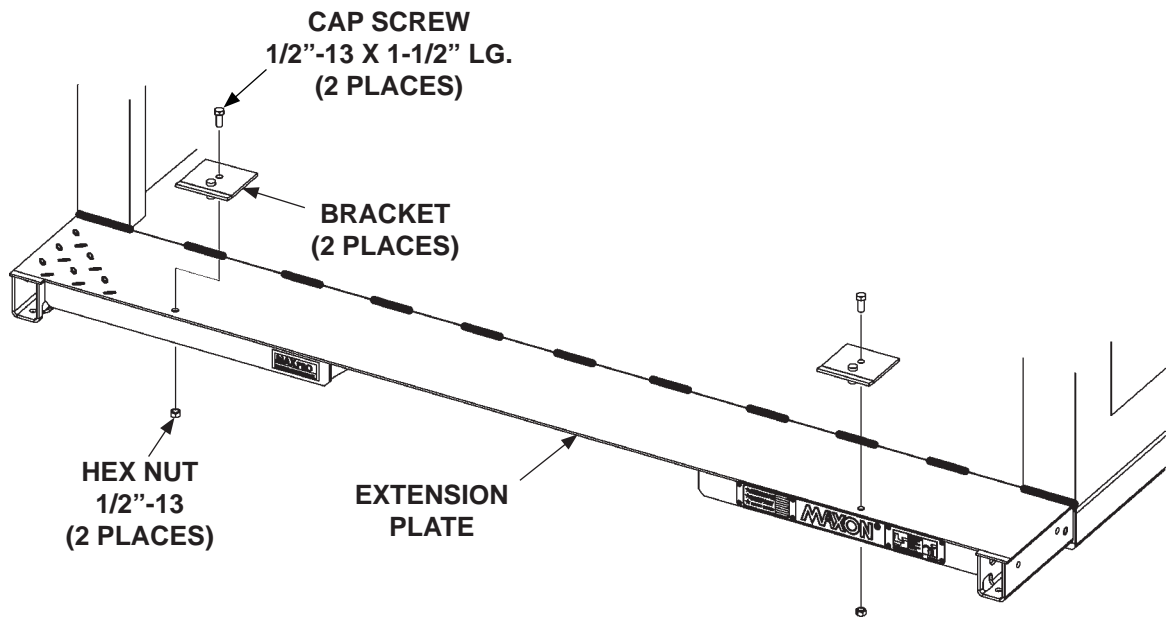

**BOLTING ON INSTALLATION BRACKETS  
FIG. 20-1**

## STEP 2 - WELD LIFTGATE TO VEHICLE

**NOTE:** TE-25 and TE-30 Liftgates are equipped with 2 types of mounting plates.

- Mounting plates on painted Liftgates are temporarily bolted to the main frame for shipping. These mounting plates must be unbolted, repositioned, and welded to main frame and truck frame as shown in these instructions.
- On galvanized Liftgates, mounting plates are bolted to the main frame. Liftgates are shipped at a standard distance of 34-1/4" between mounting plates. For narrower chassis, the RH and LH plates may be unbolted from the main frame and bolted on the opposite side. Distance is 33-3/4" between plates.

If necessary, unbolt mounting plates from galvanized main frame (FIGS. 21-1, 21-2 or 22-1). Then, bolt on opposite side (FIGS. 21-1, 21-2 or 22-1). Torque mounting plate nuts and bolts **220 - 240 lb-ft.**

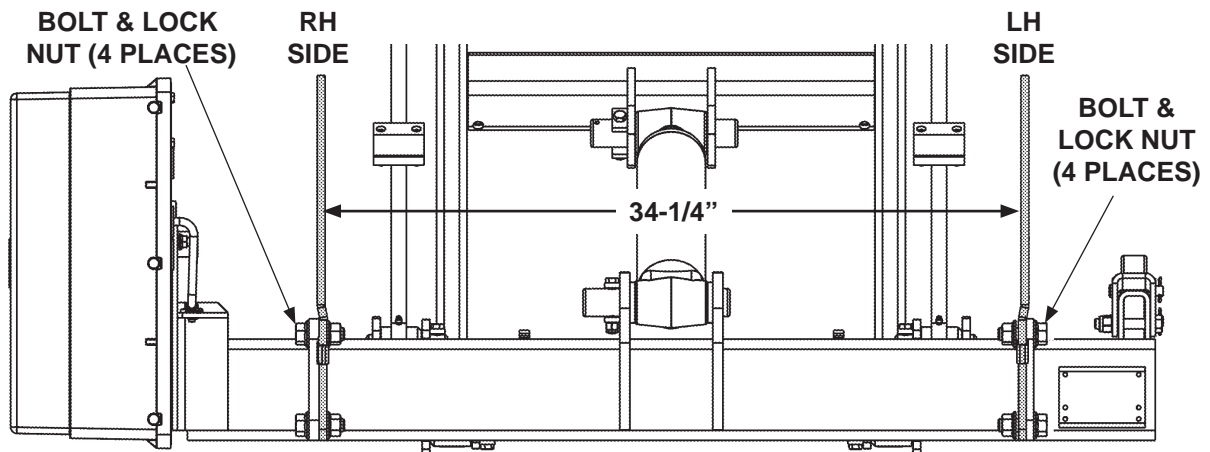

**BOLT-ON MOUNTING PLATES 34-1/4" (GALVANIZED)  
(REAR VIEW OF LIFTGATE)**

**FIG. 21-1**

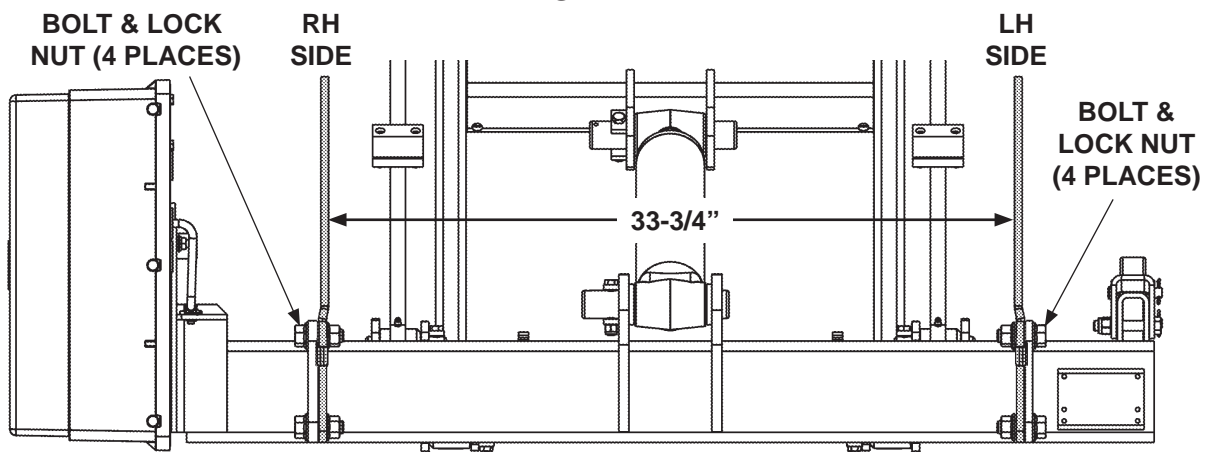

**BOLT-ON MOUNTING PLATES 33-3/4" (GALVANIZED)  
(REAR VIEW OF LIFTGATE)**

**FIG. 21-2**

## STEP 2 - WELD LIFTGATE TO VEHICLE - Continued

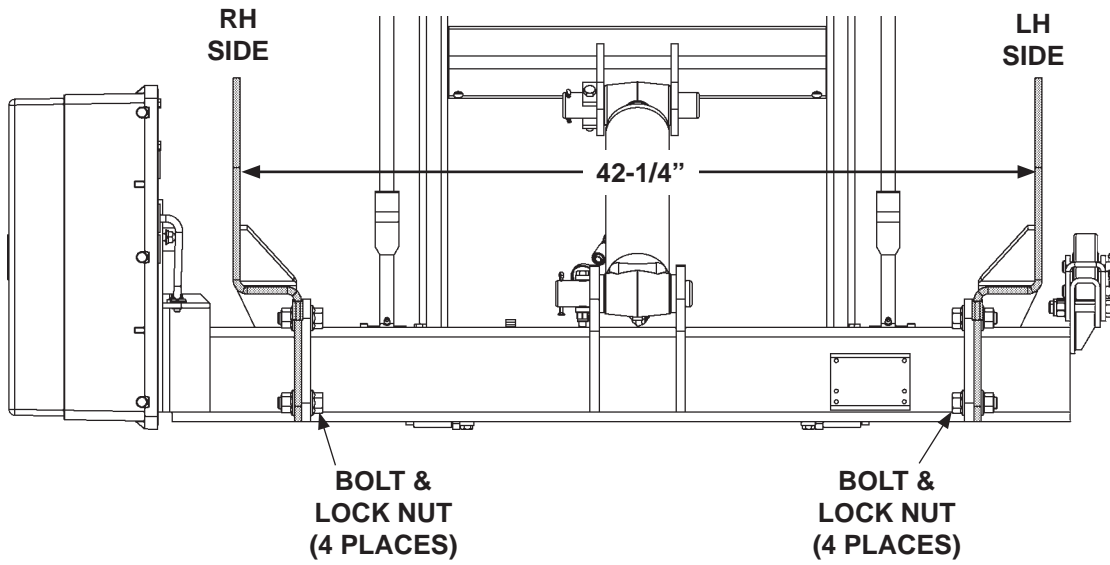

**BOLT-ON MOUNTING PLATES 42-1/4" (GALVANIZED)  
(REAR VIEW OF LIFTGATE)  
FIG. 22-1**

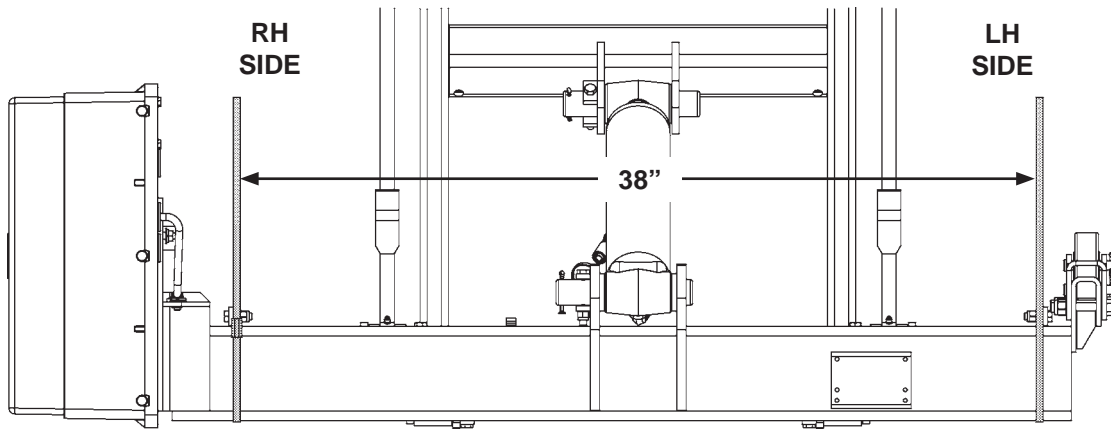

**WELD-ON MOUNTING PLATES (PAINTED) TEMPORARILY BOLTED AS SHOWN  
(REAR VIEW OF LIFTGATE)  
FIG. 22-2**

## STEP 2 - WELD LIFTGATE TO VEHICLE - Continued

### ⚠ WARNING

Do not remove lock angle except when instructed to do so in this manual.

**NOTE:** Liftgates are shipped with a locking angle that positions Liftgate correctly for high bed or low bed installation.

1. Unfold the flipover as shown in **FIG. 23-1**.
2. Measure distance "D" between the 2 cylinder pins captured by locking angle (**FIG. 23-1**). Refer to **TABLE 23-1** to verify if Liftgate is a high bed or low bed model.

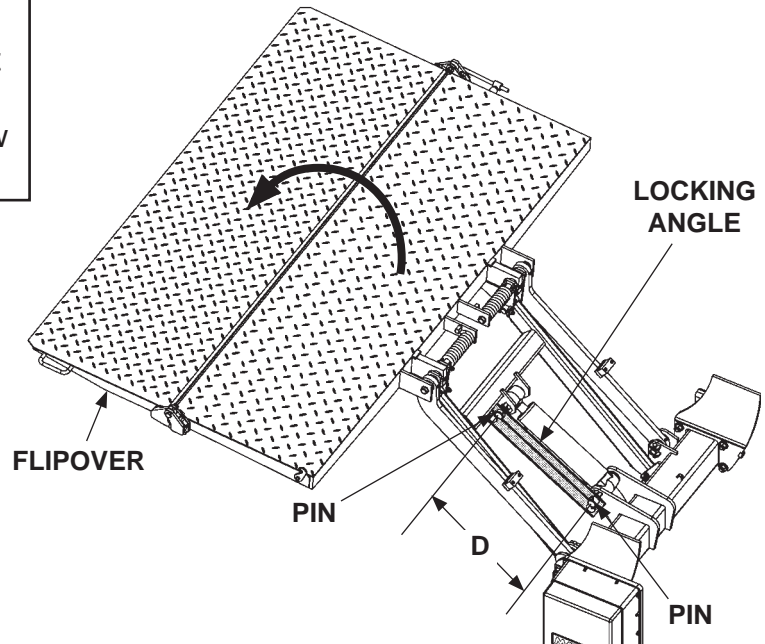

**UNFOLDING FLIPOVER**  
**FIG. 23-1**

### ⚠ WARNING

To prevent injury, support Liftgate to keep it from tipping over. Stay clear of place under the platform where Liftgate could fall on you.

### CAUTION

To prevent damage to latch on the flipover, attach hoist chains with clearance from the latch.

3. Attach chain and hoist on each side of platform near the heel (**FIG. 23-2**). (Place chain all around platform.) Hoist the Liftgate, and then place floor jack under main frame (**FIG. 23-2**). Jack the Liftgate into position. Make sure vehicle floor is horizontal. Maintain distance between floor and top of main frame as shown in **FIG. 23-2**.

LIFTGATE MODEL	DISTANCE "D" BETWEEN PINS
HIGH BED (42"-54" HT)	18-1/2"
LOW BED (36"-44" HT)	19-1/4"

**DISTANCE BETWEEN CYLINDER PINS**  
**TABLE 23-1**

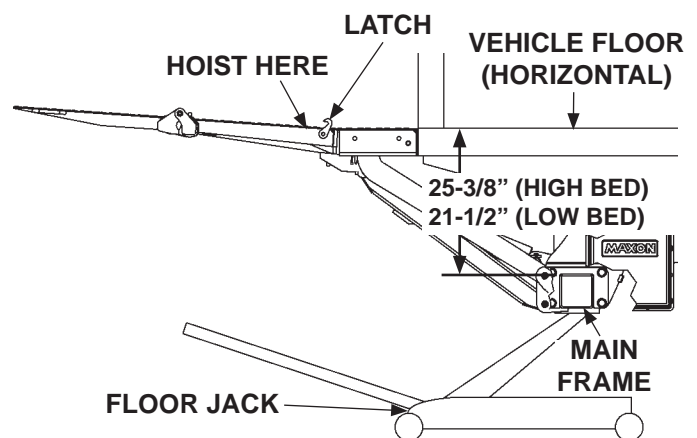

**FIG. 23-2**

## STEP 2 - WELD LIFTGATE TO VEHICLE - Continued

### CAUTION

Prevent damage to hydraulic hoses. If welding next to hydraulic hoses, use a protective cover such as a welding blanket to cover the hoses.

### CAUTION

To protect the original paint system, if equipped, a 3" wide area of paint must be removed from all sides of the weld area before welding.

### CAUTION

When using an electric welder, connect the welder ground to one of the parts being welded, as close to the weld as possible. Failure to comply could result in damage to cylinders and electrical parts.

### ⚠ WARNING

Painted Liftgate is shipped from factory with mounting plates temporarily bolted to main frame. Before operating Liftgate unbolt, position, & weld mounting plates to main frame as shown in illustrations below.

**NOTE:** On some low bed trucks, wood spacer may interfere with having two 7" vertical welds per mounting plate. If the spacer interferes with minimum 7" welds, cut and weld the top of each mounting plate 1/2" below the top radius of the truck frame.

**NOTE:** If main frame is galvanized, skip instructions 4 and 5. Go to instruction 6.

- Unbolt mounting plate from main frame. Reposition mounting plate against vehicle frame. Tack weld as shown in **FIGS. 24-1** or **25-1**. Repeat for second mounting plate (reposition and tack weld).

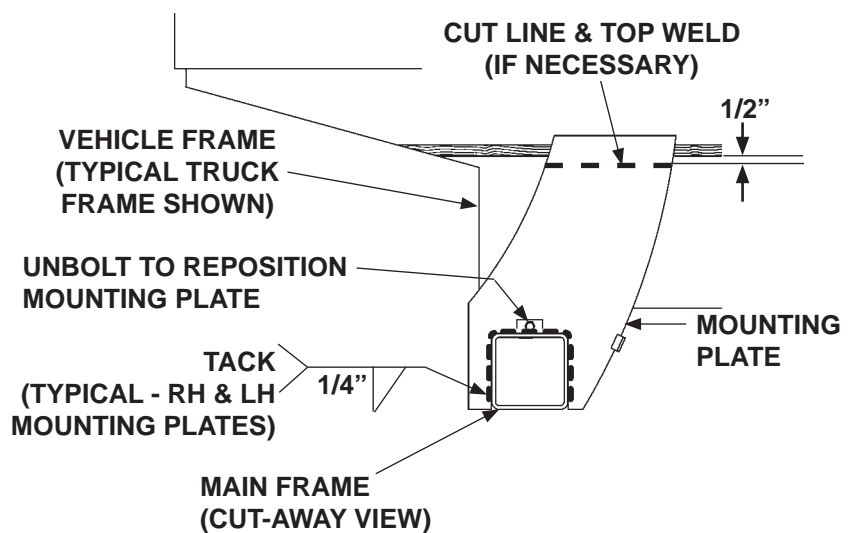

REPOSITIONING PAINTED MOUNTING PLATE  
(RH SIDE SHOWN)

FIG. 24-1



## STEP 2 - WELD LIFTGATE TO VEHICLE - Continued

**NOTE:** For painted Liftgates, weld both mounting plates to vehicle frame before fully welding mounting plates to painted main frame.

- Clamp both mounting plates to vehicle frame. Weld the mounting plates to vehicle frame as shown in **FIG. 25-1**. Remove clamps.

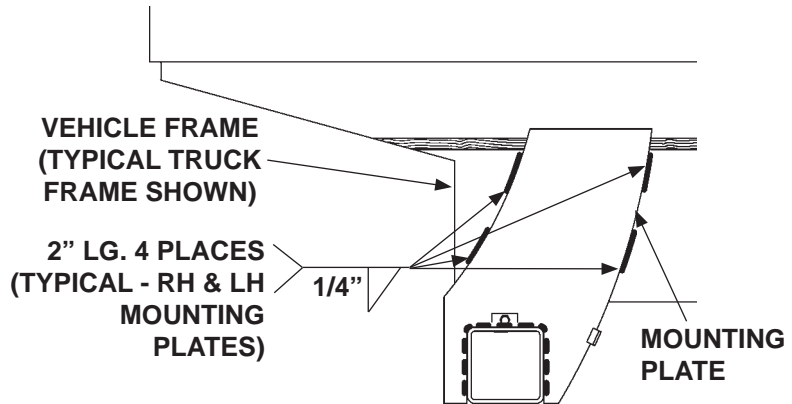

**WELD TO VEHICLE FRAME AND MAIN FRAME  
(RH SIDE SHOWN)  
FIG. 25-1**

- If necessary, unbolt mounting plate to cut at the top as shown in **FIG. 25-2**. Repeat for LH mounting plate. Then, bolt mounting plates in correct position (**FIG. 25-2**). Torque mounting plate nuts and bolts **220 - 240 lb-ft.**

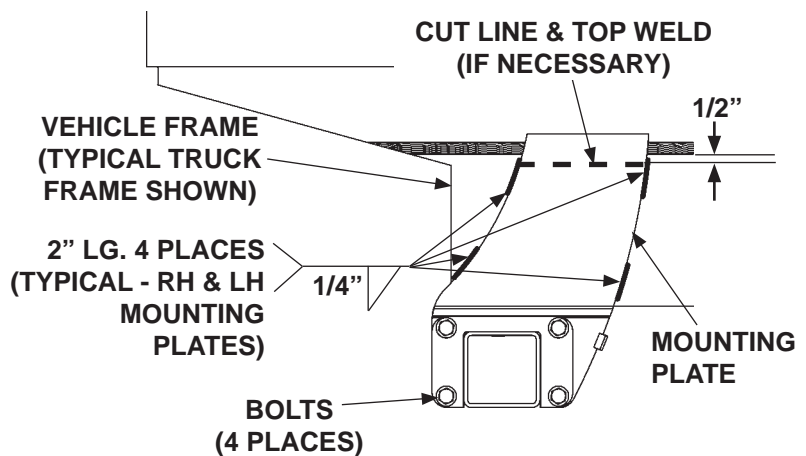

**WELD TO VEHICLE FRAME (RH SIDE SHOWN)  
FIG. 25-2**

- Clamp both mounting plates to vehicle frame. Weld the mounting plates to vehicle frame as shown in **FIGS. 25-1 and 25-2**. Remove clamps.

# STEP 3 - ATTACH OPTIONAL BATTERY BOX & FRAME TO VEHICLE (IF EQUIPPED)

## RECOMMENDED CONFIGURATION

**NOTE:** Make sure the Liftgate power unit, and all batteries on the vehicle for the power unit, are connected correctly to a common chassis ground.

1. Liftgate and optional battery box are typically installed on trucks as shown in **FIG. 26-1**. See the following page for battery and cable connections.

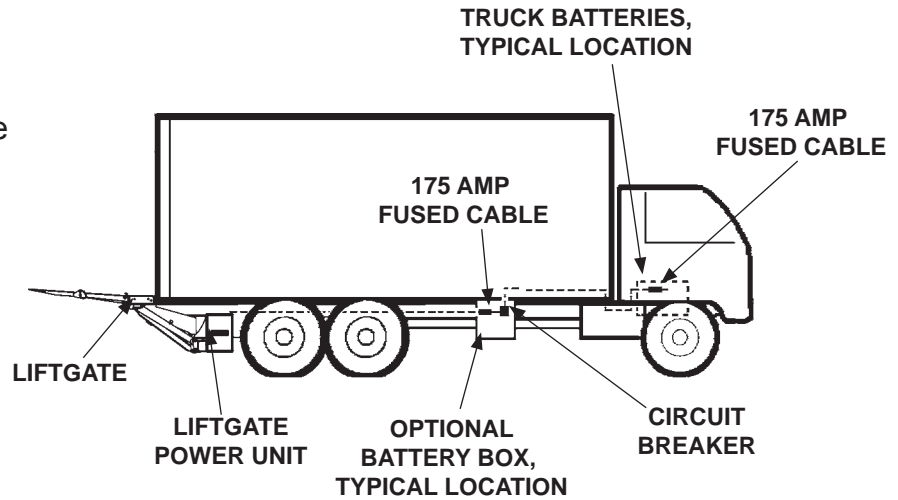

**RECOMMENDED LIFTGATE & BATTERY BOX  
INSTALLATION ON TRUCK  
FIG. 26-1**

## STEP 3 - ATTACH OPTIONAL BATTERY BOX & FRAME TO VEHICLE (IF EQUIPPED) - Continued

2. Select holes on top of battery box frame to align mounting brackets flush to cross members. Refer to **FIGS. 27-1A & 27-1B** for trailers and **FIG. 27-2** for trucks. Bolt mounting brackets to battery box frame as shown in **FIG. 27-1C**. Torque each bolt and lock nut to **85-128 lb-ft.**

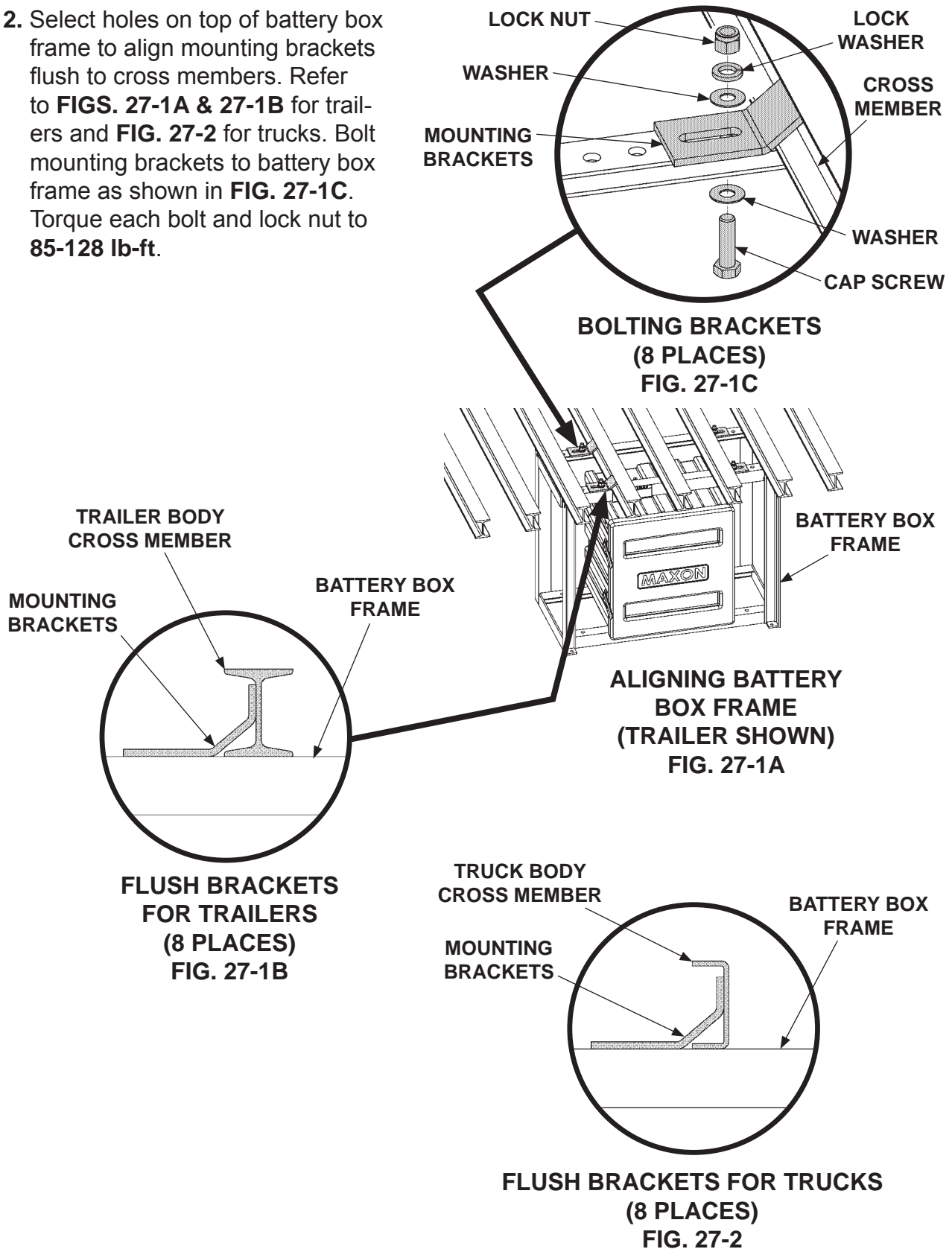

# STEP 3 - ATTACH OPTIONAL BATTERY BOX & FRAME TO VEHICLE (IF EQUIPPED) - Continued

**NOTE:** If welding mounting brackets to cross members, skip instruction 3.

- Using mounting brackets as a template mark and drill holes through cross members (FIG. 28-1). Bolt mounting brackets to cross members as shown in FIGS. 28-2A and 28-2B. Torque bolts and lock nuts to 85-128 lb-ft..

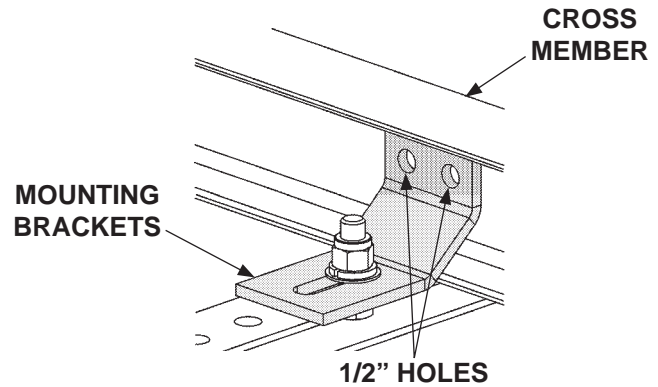

**MARK AND DRILL BRACKET HOLES**  
FIG. 28-1

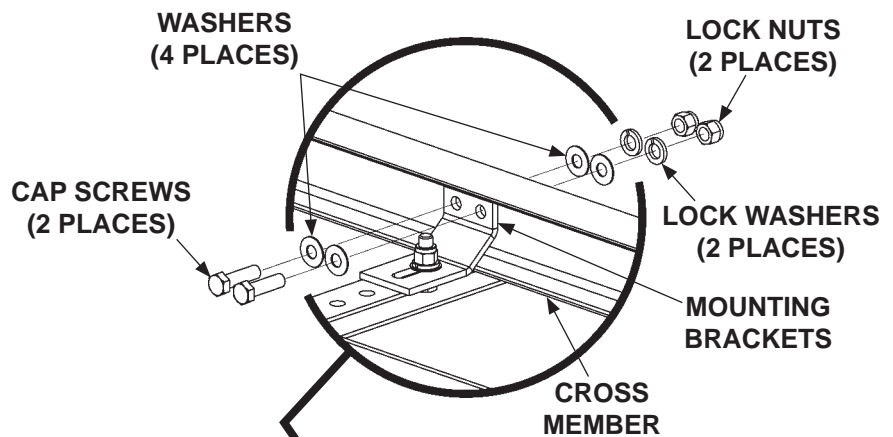

**BOLTING BRACKETS**  
(8 PLACES)  
FIG. 28-2B

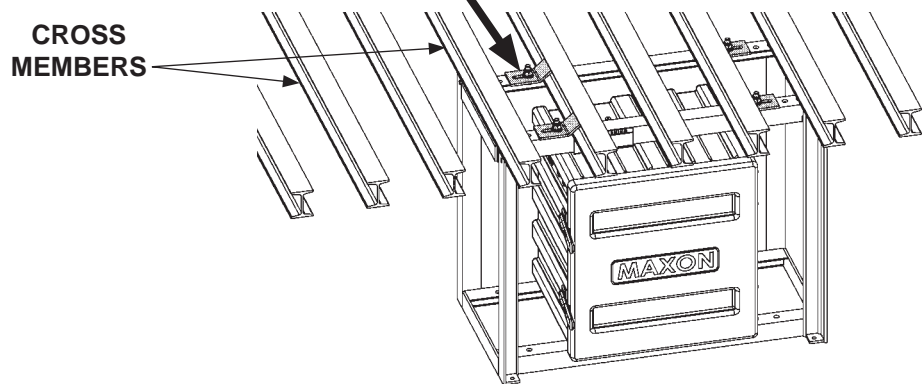

**BOLTING BATTERY BOX FRAME**  
FIG. 28-2A

## STEP 3 - ATTACH OPTIONAL BATTERY BOX & FRAME TO VEHICLE (IF EQUIPPED) - Continued

### ⚠ WARNING

Recommended practices for welding on steel parts are contained in the current AWS (American Welding Society) D1.1 Structural Welding Code - Steel. Damage to Liftgate and/or vehicle, and personal injury can result from welds that are done incorrectly.

### CAUTION

To prevent pump box components from being damaged by electric current from welding, connect welder grounding cable to the part being welded.

### CAUTION

Cover pump box and optional battery box with flame-resistant covering before welding pump box frame to vehicle.

4. Weld each bracket to cross members as shown in **FIGS. 29-1A and 29-1B**. Weld top of bracket if accessible.

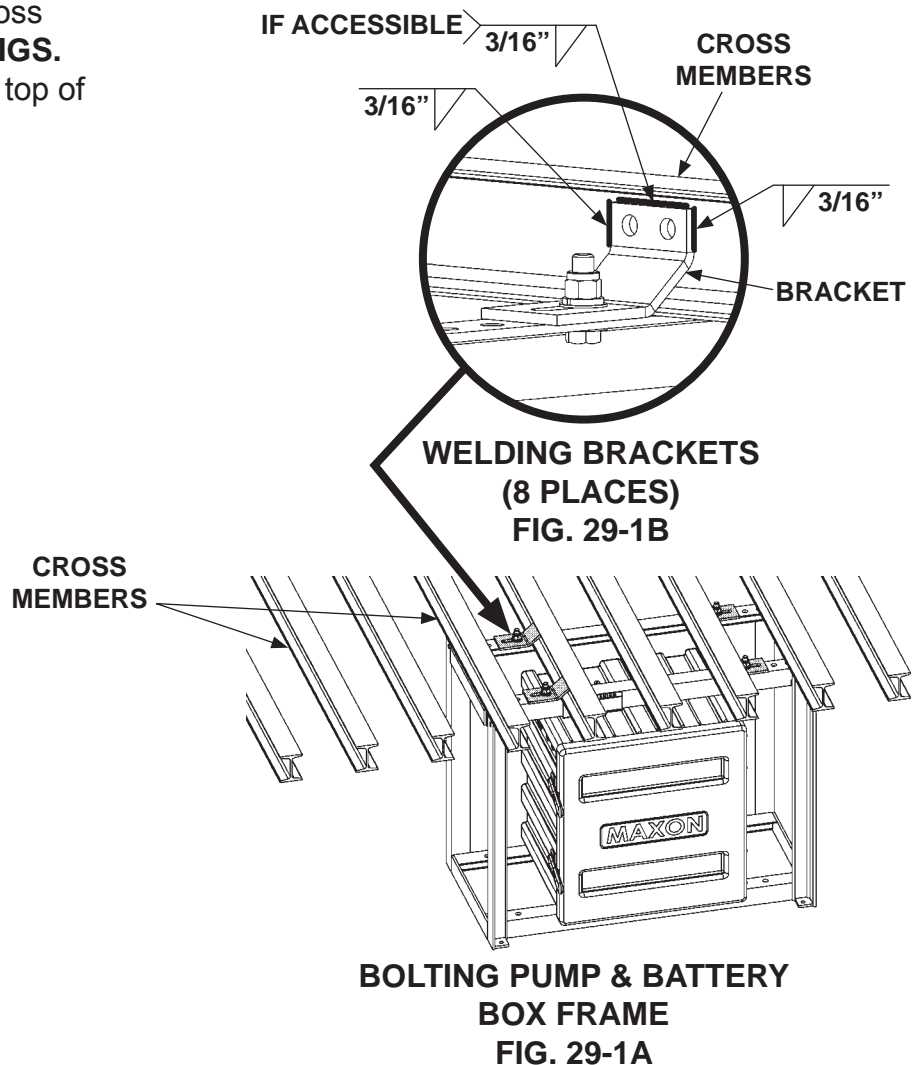

# STEP 3 - ATTACH OPTIONAL BATTERY BOX & FRAME TO VEHICLE (IF EQUIPPED) - Continued

## ⚠ WARNING

Remove all rings, watches and jewelry before doing any electrical work.

**NOTE:** Always connect fused end of power cable to battery positive (+) terminal.

**NOTE:** To connect charge lines, refer to instructions provided with each charge line kit.

5. Connect battery cables, fused cables, and ground cables for 12 volt power as shown in **FIG. 30-1** or 24 volt power as shown in **FIG. 31-1**.

GROUND CABLE TO PUMP BOX OR COMMON CHASSIS GROUND, 74" LG. (BATTERY BOX KIT ITEM)

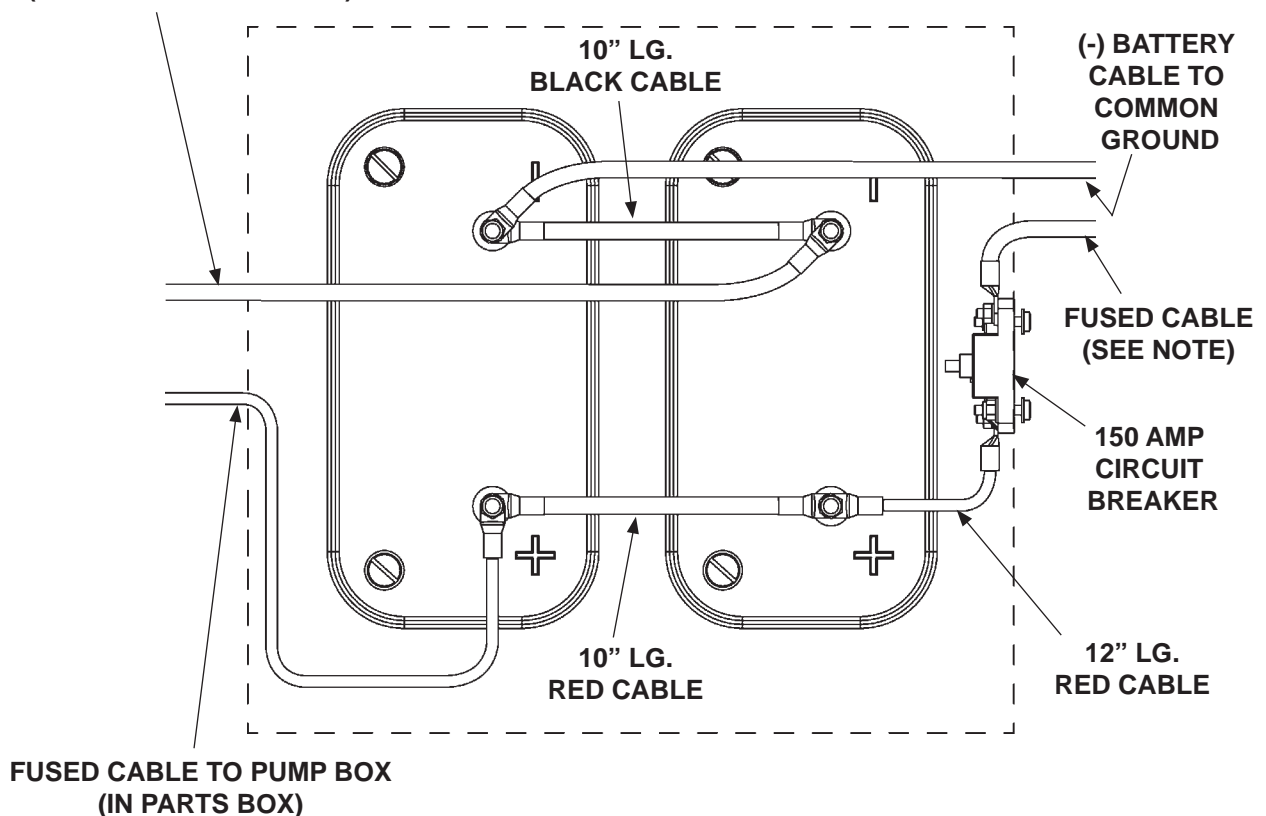

12 VOLT BATTERY CONNECTIONS FOR 12 VOLT POWER  
FIG. 30-1

# STEP 3 - ATTACH OPTIONAL BATTERY BOX & FRAME TO VEHICLE (IF EQUIPPED) - Continued

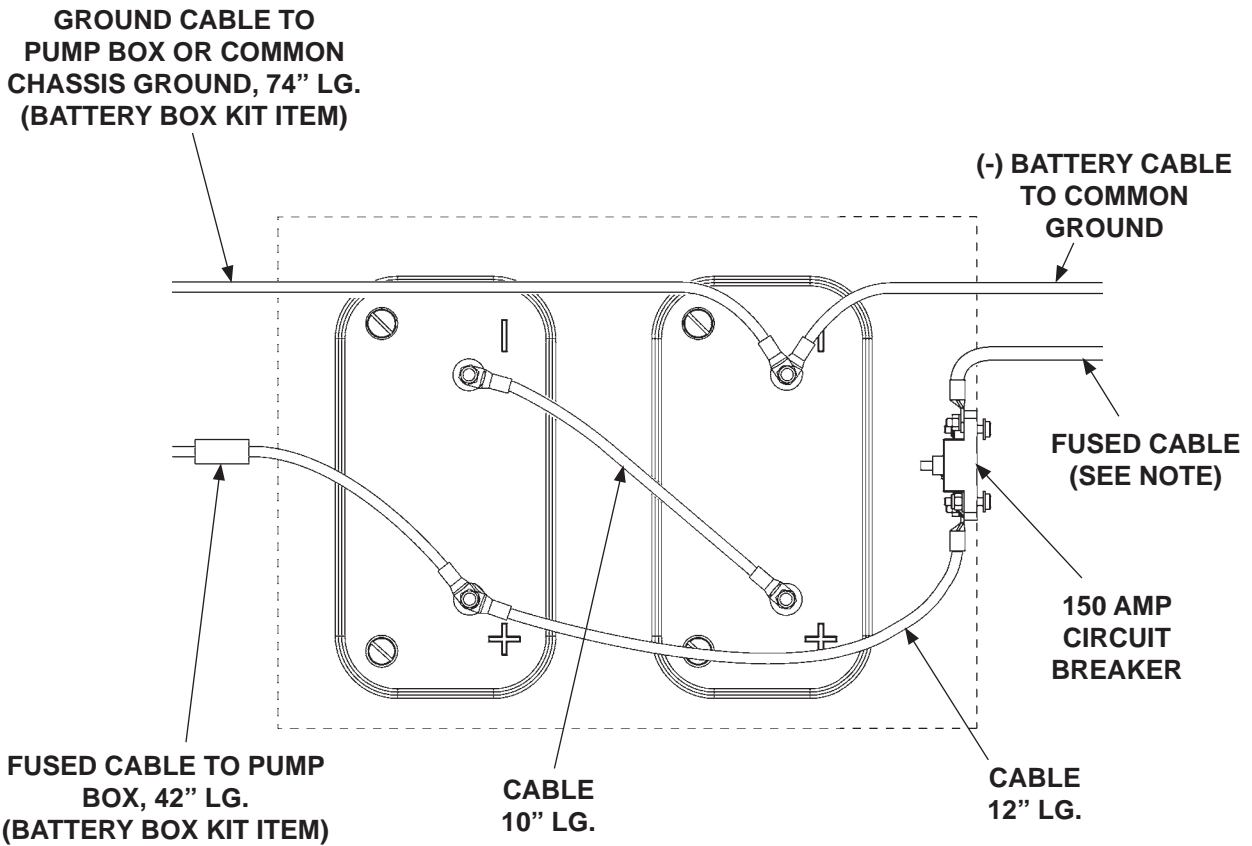

**12 VOLT BATTERY CONNECTIONS FOR 24 VOLT POWER  
FIG. 31-1**

## STEP 3 - ATTACH OPTIONAL BATTERY BOX & FRAME TO VEHICLE (IF EQUIPPED) - Continued

### ⚠ WARNING

Explosive hydrogen gas from charging batteries can accumulate in battery box if not vented from the box. To prevent hydrogen gas from accumulating, ensure the 3 ventilation holes in battery box are not plugged or covered.

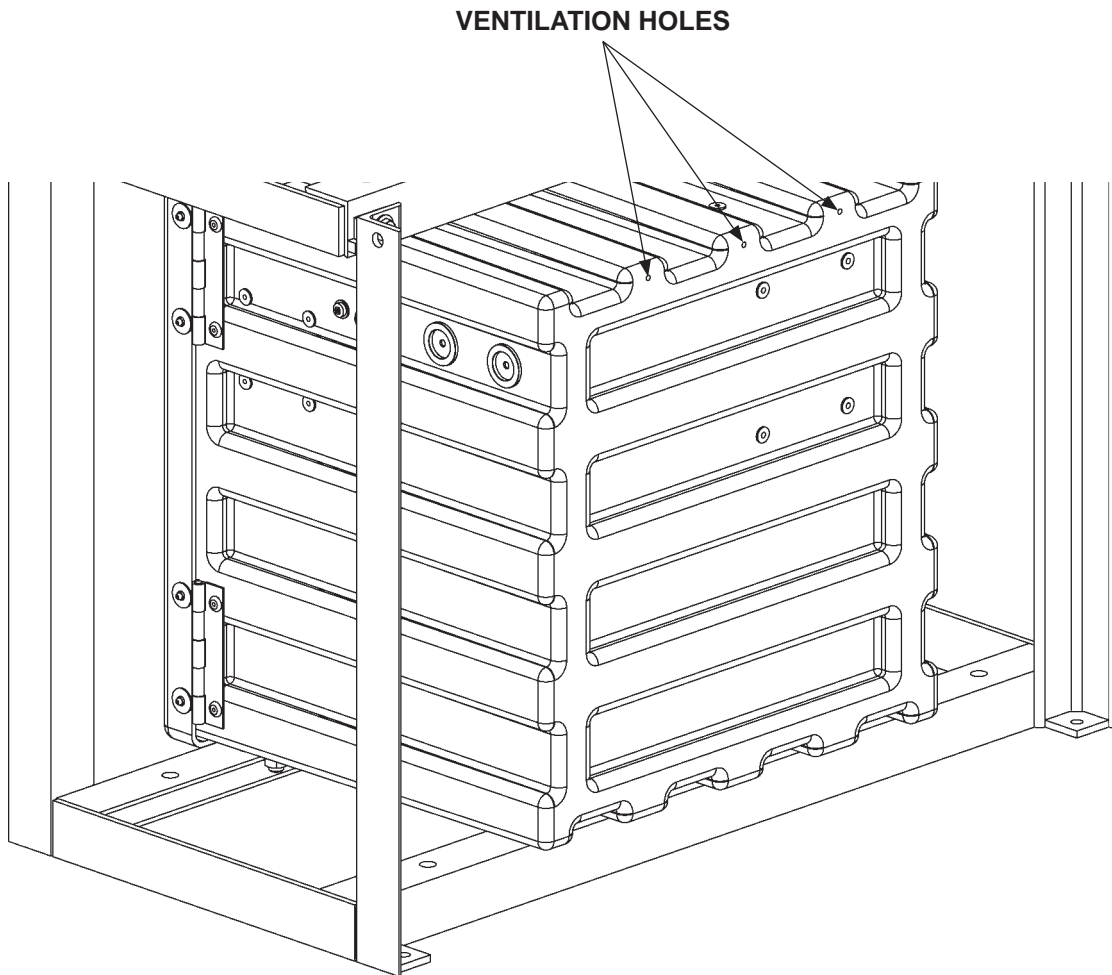

BATTERY BOX ASSEMBLY (REAR VIEW SHOWN)  
FIG. 32-1



# STEP 3 - ATTACH OPTIONAL BATTERY BOX & FRAME TO VEHICLE (IF EQUIPPED) - Continued

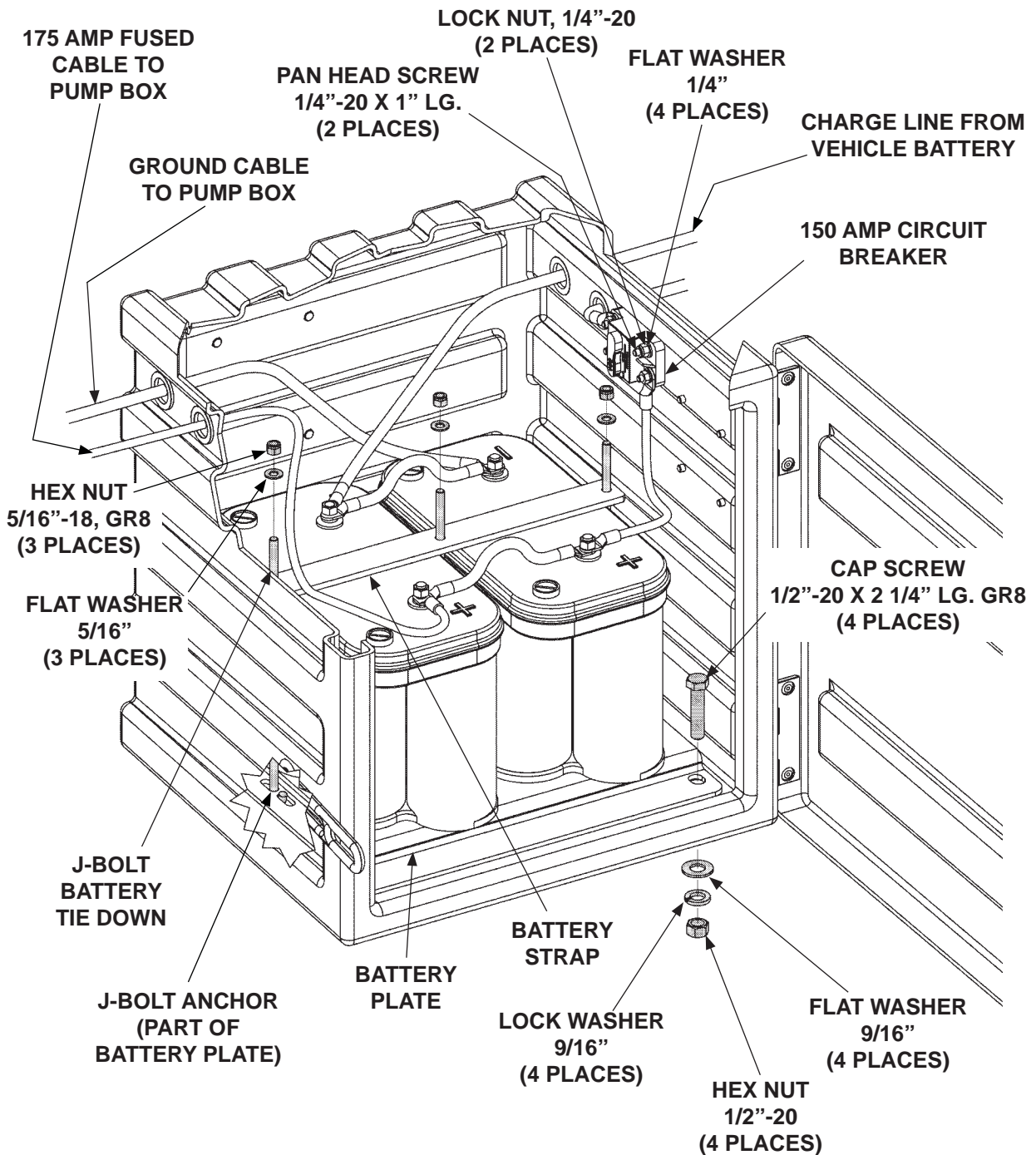

**BATTERY BOX ASSEMBLY  
(12 VOLT POWER CONNECTIONS SHOWN)**

**FIG. 33-1**

## STEP 4 - RUN POWER CABLE

**NOTE:** Make sure the Liftgate power unit, and all batteries on the vehicle for the power unit, are connected correctly to a common chassis ground.

### RECOMMENDED CONFIGURATION

1. Liftgate powered from truck batteries is typically installed on trucks as shown in **FIG. 34-1**. See the following page for running the battery cable.

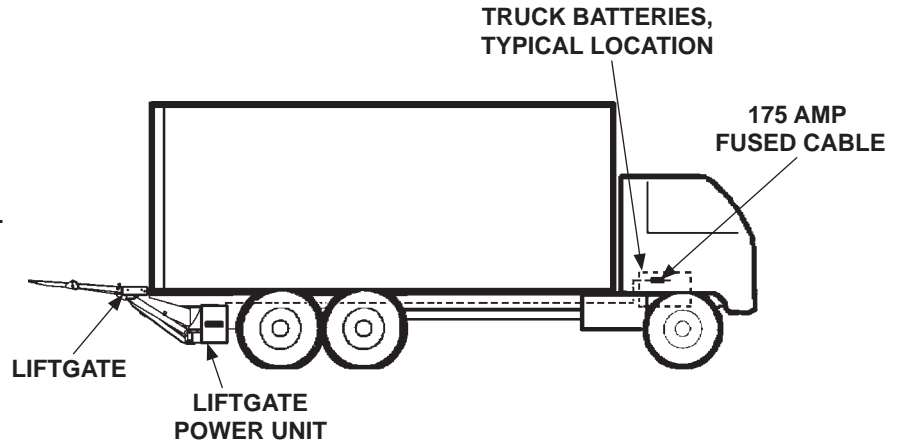

### RECOMMENDED LIFTGATE & BATTERY BOX INSTALLATION ON TRUCK

FIG. 34-1

## STEP 4 - RUN POWER CABLE - Continued

### ⚠ CAUTION

Never route an energized wire. Make sure the vehicle battery is disconnected. Always route electrical wires clear of moving parts, brake lines, sharp edges and exhaust systems. Avoid making sharp bends in wiring. Attach securely. If drilling is necessary, first check behind the drilling surface so you do not damage any fuel lines, vent lines, brake lines or wires.

2. Clip fused power cable to vehicle chassis with fuse nearest the vehicle battery, as shown in **FIG. 35-1**. Keep enough cable near the battery to reach the positive terminal without straining cable (after connection). Run cable to pump box on Liftgate.

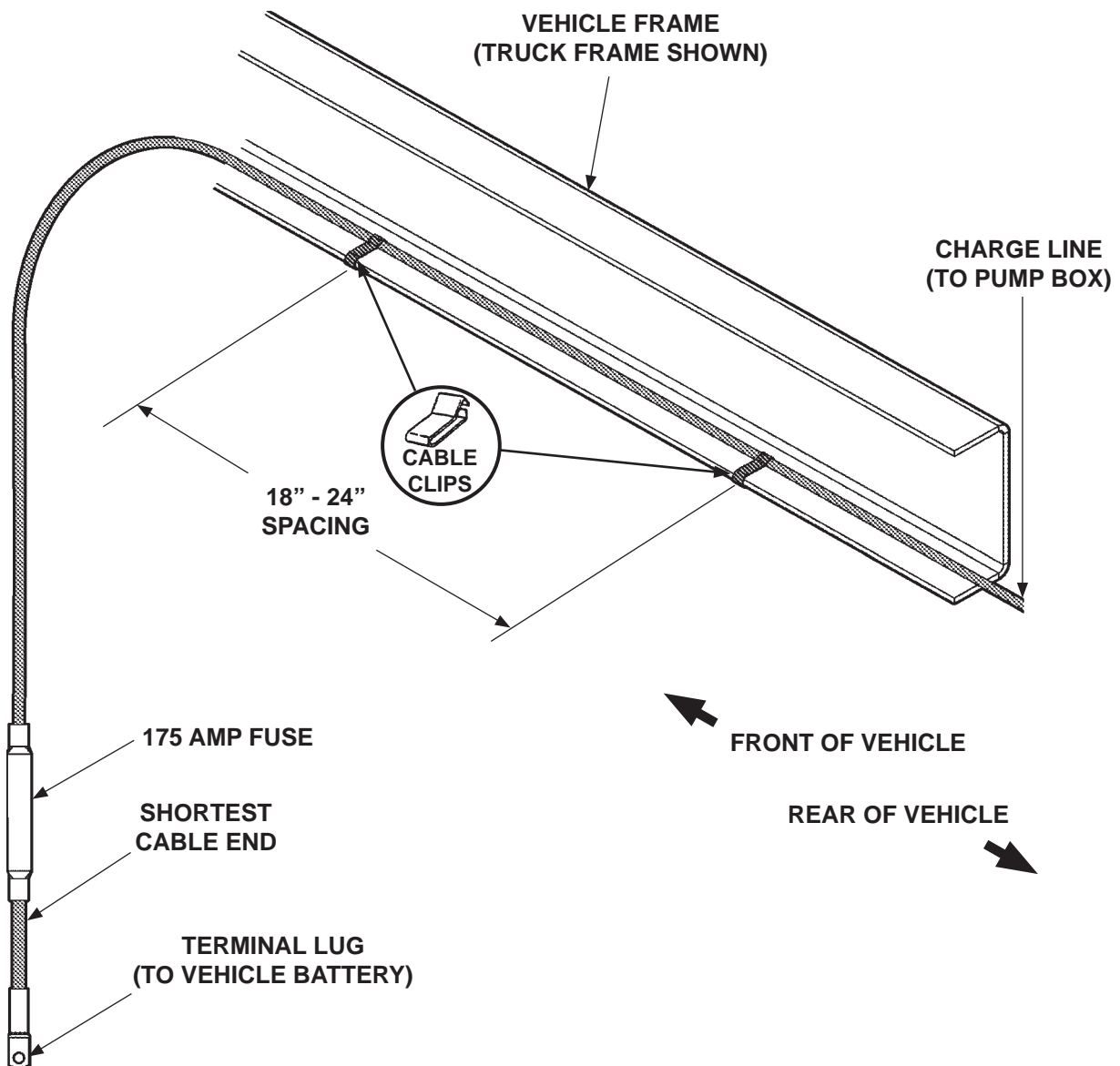
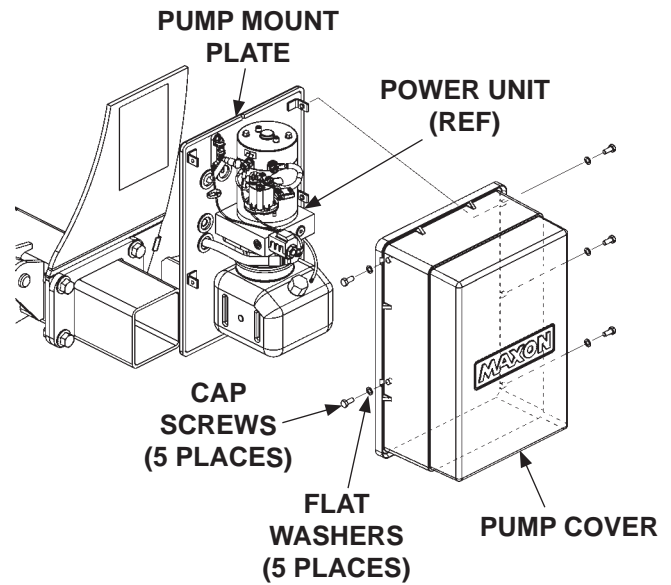

FIG. 35-1

## STEP 5 - CONNECT POWER CABLE

1. Unbolt the pump cover as shown in **FIG. 36-1**.



**UNBOLTING PUMP COVER  
FIG. 36-1**

## STEP 5 - CONNECT POWER CABLE - Continued

**NOTE:** Hydraulic lines and electrical lines must be run into pump box through sealing grommets (FIG. 37-3). To ensure a good seal on hydraulic & electrical lines, never cut the sealing grommets.

- On the bare wire end of fused power cable, keep enough length to attach copper terminal lug and reach motor solenoid without putting tension on cable (after connection) (FIG. 37-1). Measure (if needed) and then cut excess cable from bare wire end of cable. Put heat shrink tubing (parts box) (FIG. 37-2) on the end of the cable (leave room for terminal lug). Crimp copper terminal lug (from parts box) on the fused power cable and shrink the heat shrink tubing (FIG. 37-2).

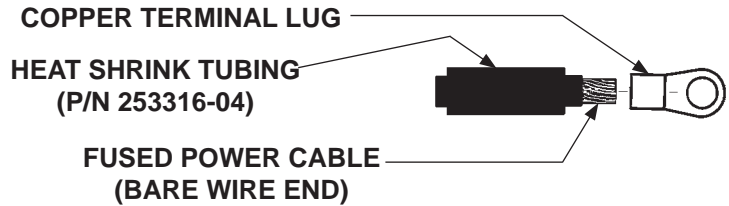

**PLACING TERMINAL LUG & HEAT SHRINK TUBING ON FUSED POWER CABLE**  
FIG. 37-1



**TYPICAL FUSED POWER CABLE WITH TERMINAL LUG INSTALLED**  
FIG. 37-2

### CAUTION

Do not over-tighten the terminal nuts. For the 5/16" load terminals, torque nuts to 35 lb-in. Torque the nuts on #10-32 control terminals to 15 lb-in.

- Remove hex nut and lock washer from battery terminal post on the motor solenoid. Connect the fused power cable to the motor solenoid as shown in FIG. 37-3. Reinstall and tighten lock washer and hex nut.

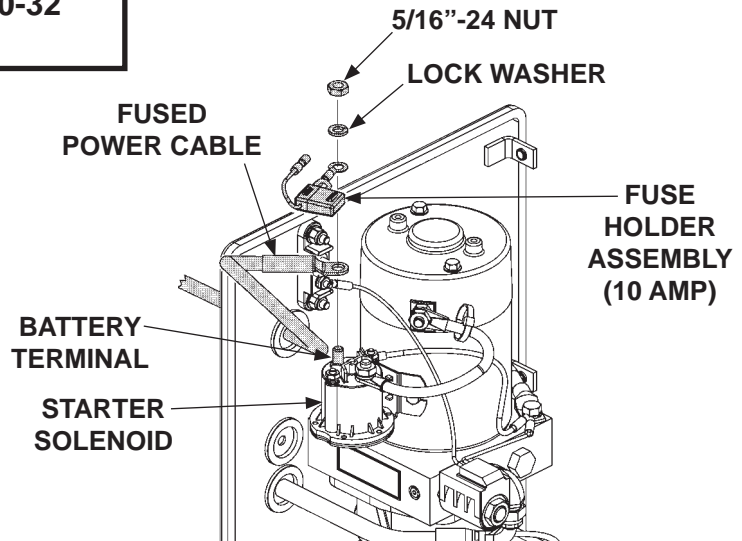

**TYPICAL FUSED POWER CABLE CONNECTION (GRAVITY DOWN PUMP SHOWN)**  
FIG. 37-3

# STEP 6 - CONNECT GROUND CABLE (RECOMMENDED)

**NOTE:** To ensure power unit is correctly grounded, MAXON recommends connecting optional 2 gauge ground cable from grounding stud on pump assembly to a grounding point on the frame, or negative battery terminal in the optional battery box.

1. Unbolt pump ground cable from the pump mounting bracket. Then, bolt and tighten pump ground cable and external ground cable (parts box) to mounting bracket (**FIG. 38-1**).

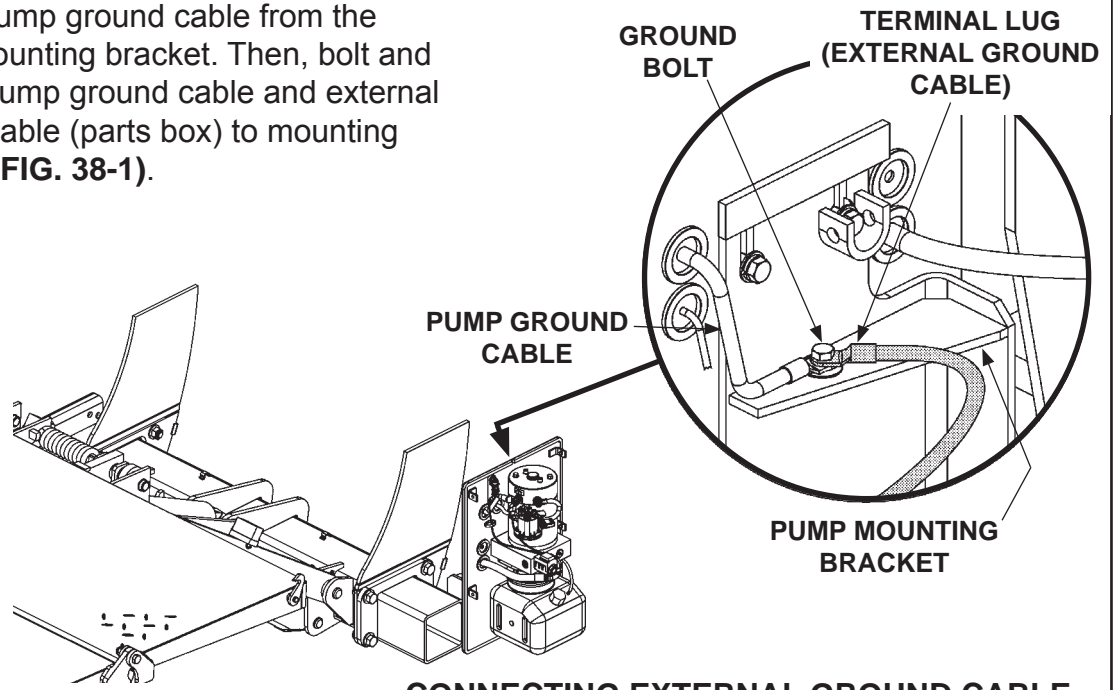

**CONNECTING EXTERNAL GROUND CABLE  
FIG. 38-1**

**NOTE:** If there is a grounding point on the frame, use it to connect ground cable. Then, skip the step for drilling a hole.

**NOTE:** Clean the ground cable connection point on the frame down to bare metal.

2. Extend the ground cable to reach vehicle frame (**FIG. 38-2**) without putting tension on cable (after connection). Connect to an existing grounding point if available.
3. If necessary, drill a 11/32" (0.343") hole in vehicle frame for bolting the ground cable terminal lug (**FIG. 38-2**).
4. Bolt the ground cable terminal lug to vehicle frame as shown in **FIG. 38-2**.

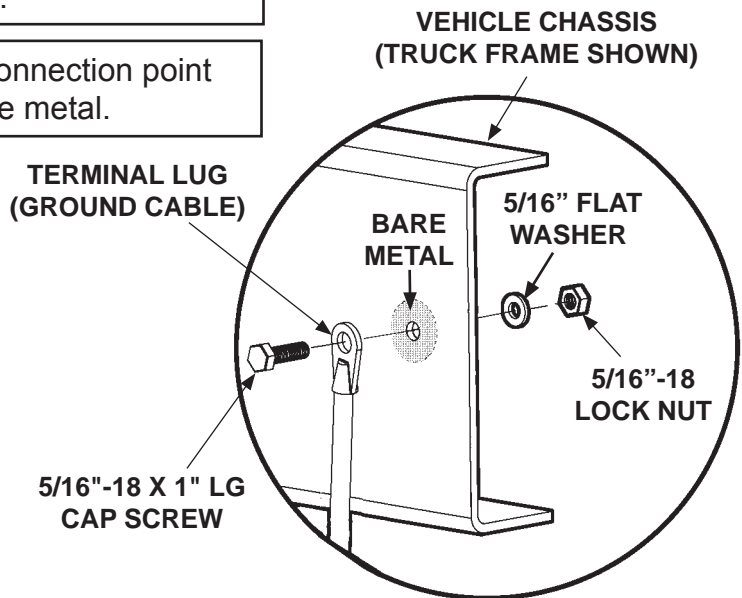

**FIG. 38-2**

## STEP 7 - INSTALL CONTROL SWITCH

1. Measure, mark and drill one 3/4" hole and two #21-size holes in the vertical post on curb side of vehicle body as shown in **FIG. 39-1**.

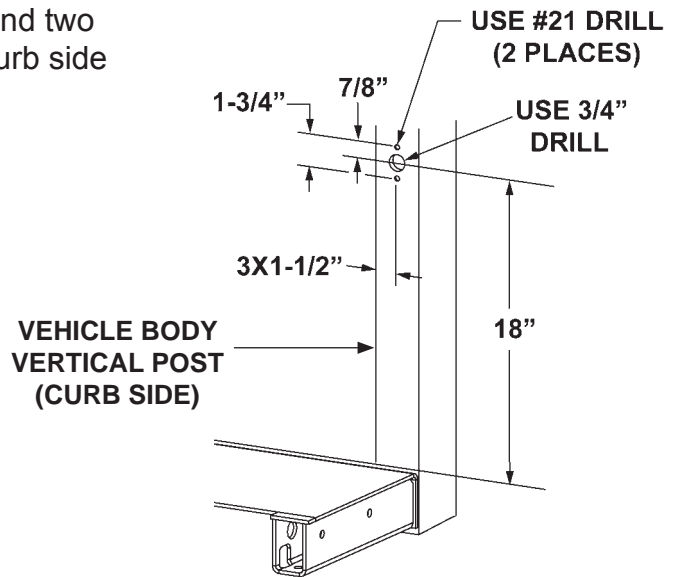

**DRILLING MOUNTING HOLES  
FIG. 39-1**

2. Insert control switch wiring (parts box) into the 3/4" hole on the corner post, down the corner post, and under the vehicle body to the pump assembly.  
(See dashed line - **FIG. 39-2**.)

3. Push control switch and cable back into the 3/4" hole in the vertical post until control switch touches the post (**FIG. 39-2**). Attach control switch to vertical post with 2 self-tapping screws (parts box) (**FIG. 39-2**).

#10-24 X 1-1/2" LG. SELF-TAPPING SCREWS

CONTROL SWITCH

VEHICLE BODY  
VERTICAL POST

3/4" HOLE

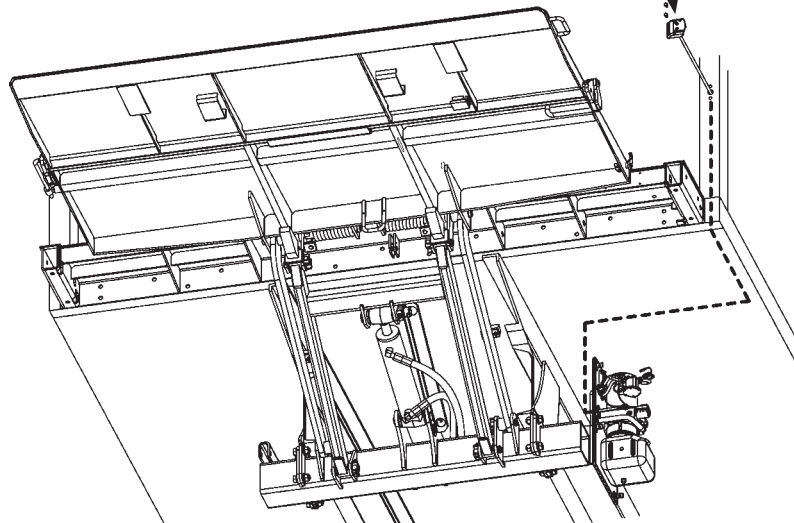

**ROUTING CONTROL SWITCH WIRING  
FIG. 39-2**

4. If necessary, use clamps and self-tapping screws (parts box) to secure switch cable to vehicle under-body and frame (**FIG. 39-2**).

## STEP 7 - INSTALL CONTROL SWITCH - Continued

### CAUTION

Do not over-tighten the terminal nuts. For the 5/16" load terminals, torque nuts to 35 lb-in. Torque the nuts on #10-32 control terminals to 15 lb-in.

**NOTE:** Hydraulic lines and electrical lines run into pump box through sealing grommets (FIG. 40-1). To ensure a good seal on hydraulic & electrical lines, never cut the sealing grommets.

5. Insert switch wiring through grommet on pump mounting plate (FIG. 40-1). Connect the switch wiring to the pump assembly as shown in FIG. 40-1.

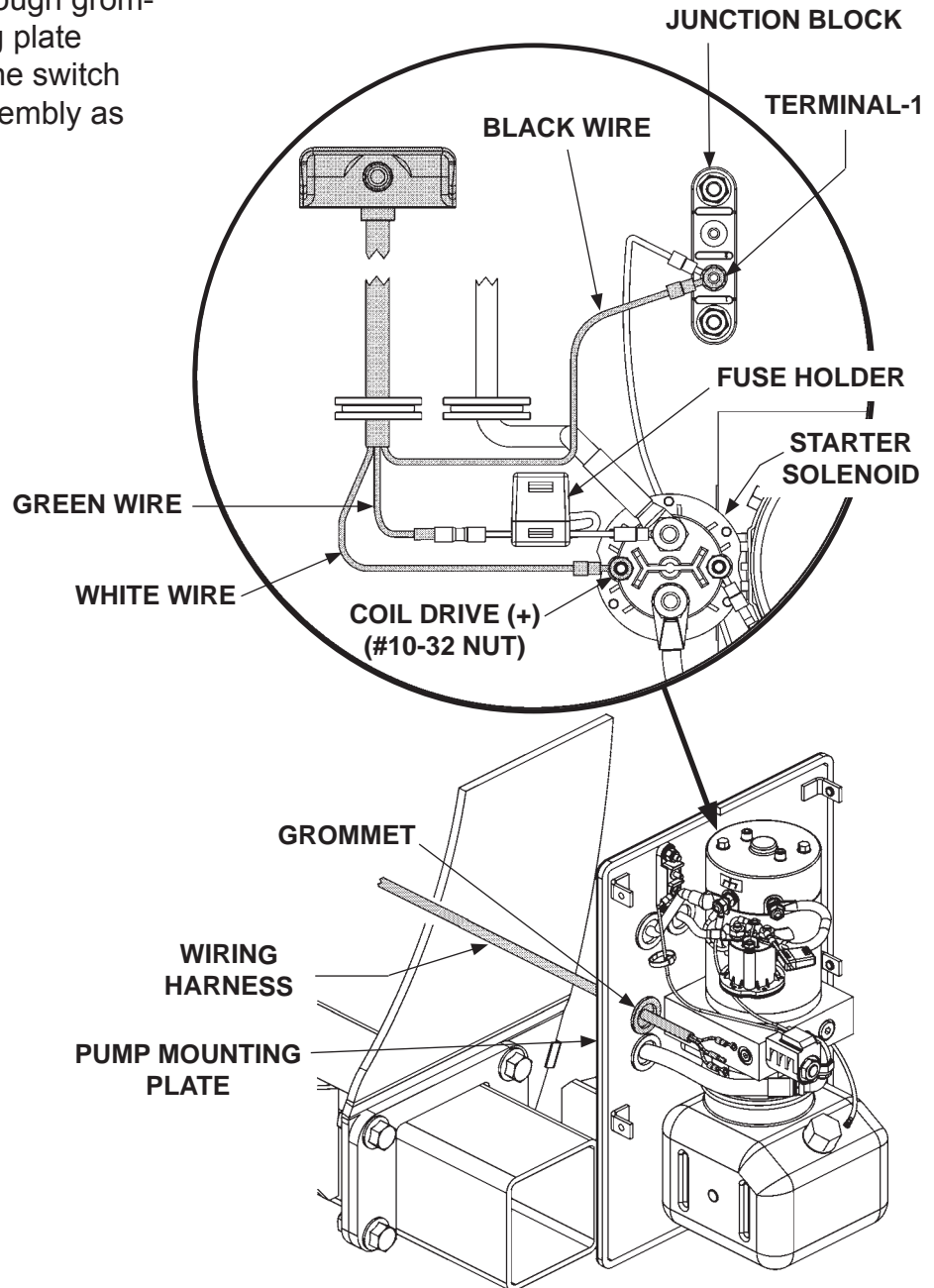

CONTROL SWITCH CONNECTED TO  
GD PUMP ASSEMBLY

FIG. 40-1



# STEP 7 - INSTALL CONTROL SWITCH - Continued

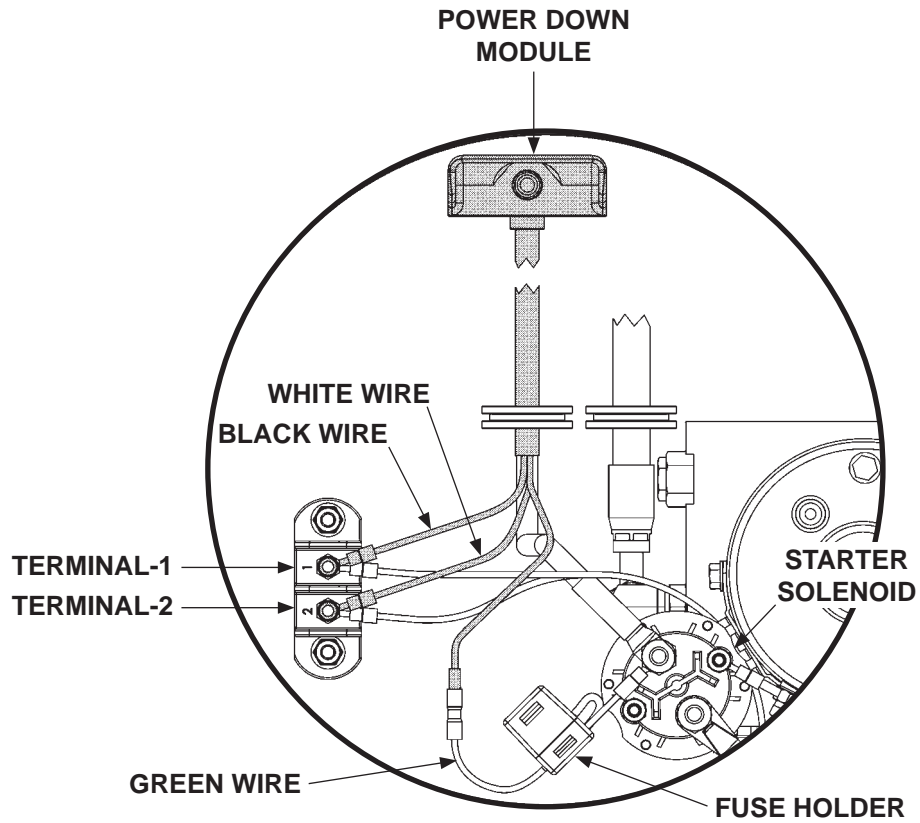

**CONTROL SWITCH CONNECTED TO  
PD PUMP ASSEMBLY  
FIG. 41-1**

## STEP 8 - CHECKING HYDRAULIC OIL

### CAUTION

Keep dirt, water and other contaminants from entering the hydraulic system. Before opening the hydraulic fluid reservoir filler cap, drain plug and hydraulic lines, clean up contaminants that can get in the openings. Also, protect the openings from accidental contamination.

**NOTE:** Liftgate is shipped with **ISO 32** oil. Use correct oil for climate conditions.

**+50 to +120 Degrees F - Grade ISO 32**

**Below + 70 Degrees F - Grade ISO 15 or MIL-H-5606**

See **TABLES 43-1 & 43-2** for recommended brands of **ISO 32 & ISO 15** oils.

**NOTE:** Hydraulic oil level must be minimum of 1-1/2" above the bottom of reservoir to operate Liftgate.

1. With platform at bed height, check oil level in the pump reservoir (**FIG. 42-1**). To add oil, pull out filler cap (no threads) (**FIG. 42-1**). Add hydraulic oil in reservoir to the level shown in **FIG. 42-1**.

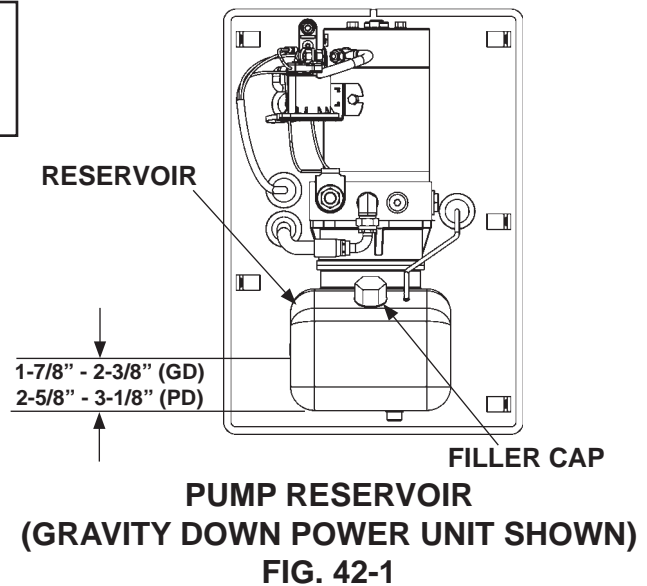

2. Reinstall filler cap (**FIG. 42-1**).

3. Bolt on the pump cover as shown in **FIG. 42-2**. Torque the bolts (cap screws) to **10 - 14 lb-in.**

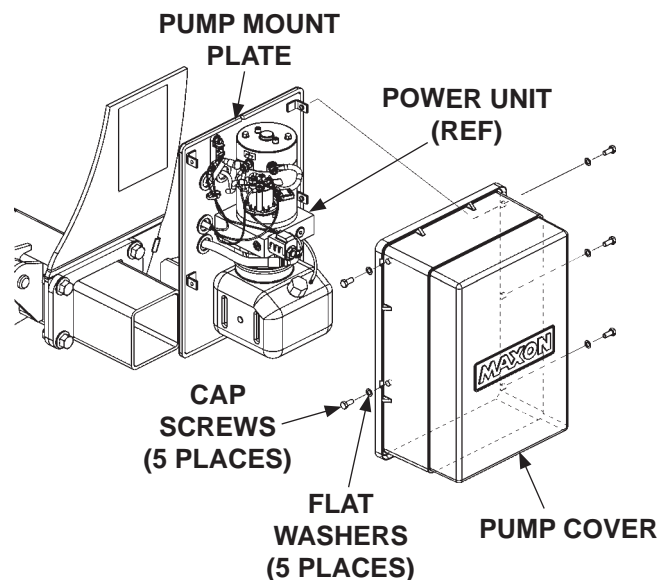

**BOLTING ON PUMP COVER**  
**FIG. 42-2**

## STEP 8 - ADD HYDRAULIC FLUID - Continued

ISO 32 HYDRAULIC OIL	
RECOMMENDED BRANDS	PART NUMBER
CHEVRON	HIPERSYN 32
KENDALL	GOLDEN MV
SHELL	TELLUS S2 VX 32
EXXONMOBIL	UNIVIS N-32, DTE-24

**TABLE 43-1**

ISO 15 OR MIL-H-5606 HYDRAULIC OIL	
RECOMMENDED BRANDS	PART NUMBER
CHEVRON	FLUID A, AW-MV-15
KENDALL	GLACIAL BLU
SHELL	TELLUS S2 VX 15
EXXONMOBIL	UNIVIS HVI-13
ROSEMEAD	THS FLUID 17111

**TABLE 43-2**

## STEP 9 - CONNECT POWER CABLE TO BATTERY

1. Remove nut from negative (-) battery terminal. Disconnect negative (-) battery cable (FIG. 44-1).

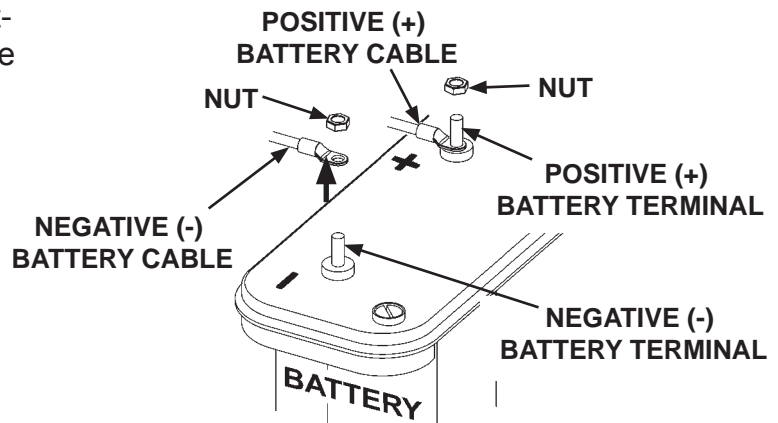

DISCONNECTING (-) BATTERY CABLE  
FIG. 44-1

2. Remove nut from positive (+) battery terminal (FIG. 44-1).

3. Connect fused positive (+) cable to positive (+) battery terminal (FIG. 44-2). Then, reinstall nut on positive (+) battery terminal (FIG. 44-2).

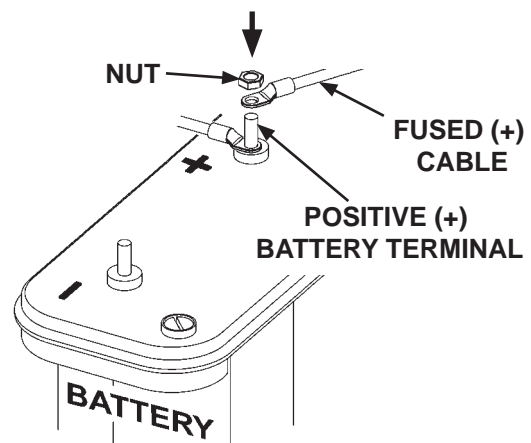

CONNECTING FUSED (+) CABLE  
FIG. 44-2

4. Reconnect negative (-) battery cable to negative (-) battery terminal (FIG. 44-3). Then, reinstall nut on negative (-) battery terminal (FIG. 44-3).

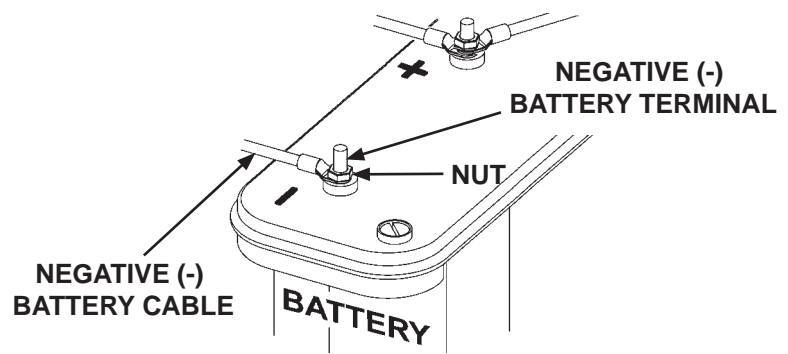

RECONNECTED BATTERY CABLES  
FIG. 44-3

# STEP 10 - REMOVE LOCKING ANGLE AND CHECK FOR INTERFERENCE

## CAUTION

Do not fully pressurize the system in this step. Fully pressurize the system and check for hydraulic leaks after Liftgate is fully welded.

1. Push control switch to **UP** position and hold just enough time to pressurize hydraulic system. Release control switch. Hydraulic system is ready.

## ⚠ WARNING

To prevent possible injury, never work in the area under the platform. Get access to the locking angle from the back of the Liftgate.

**NOTE:** To operate Liftgate, locking angle must be removed from hydraulic cylinder.

2. Remove cotter pins (**FIG. 45-1**) from 2 cylinder pins. Remove the locking angle (**FIG. 45-1**).

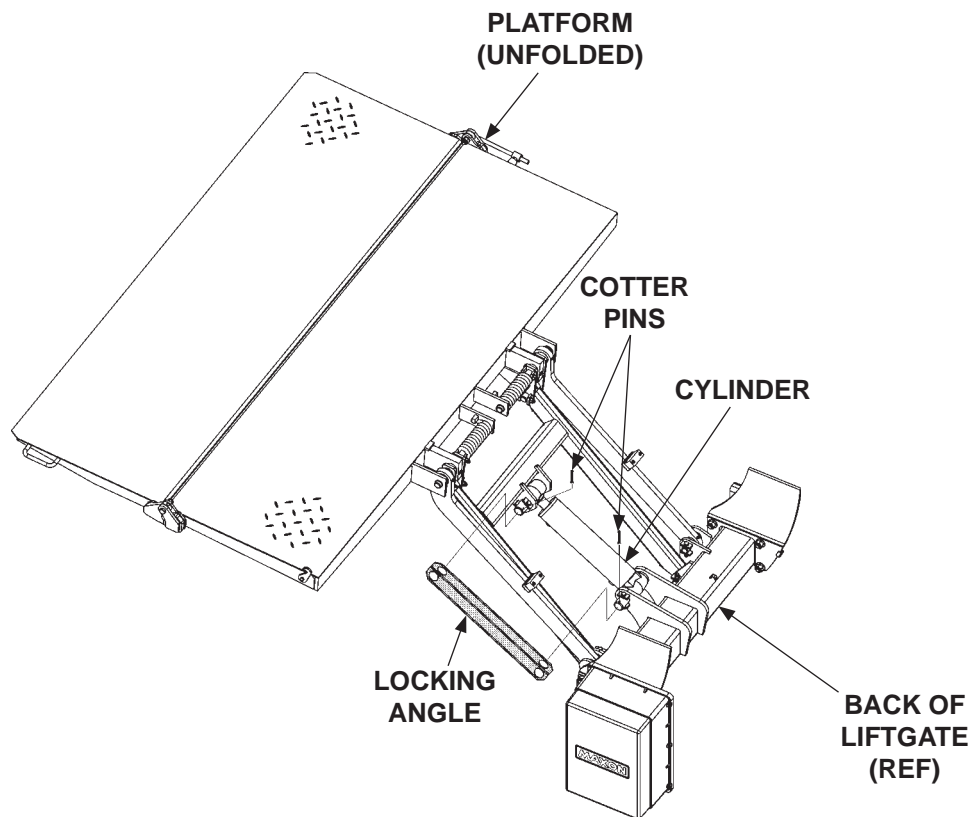

REMOVING LOCKING ANGLE  
FIG. 45-1

## STEP 10 - REMOVE LOCKING ANGLE AND CHECK FOR INTERFERENCE - Continued

3. Remove floor jack and hoist supporting Liftgate (FIG. 46-1).

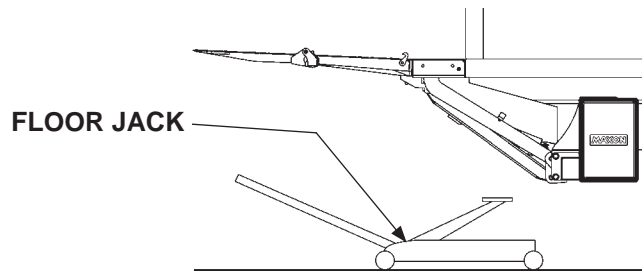
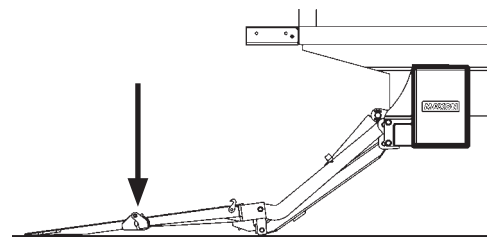
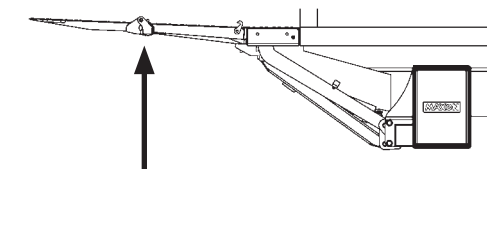

FIG. 46-1

4. Lower platform to the ground (FIG. 46-2). Look for any interference between liftgate and vehicle as platform is lowered. Then, raise the platform (FIG. 46-3). Look for any interference between liftgate and vehicle as platform is raised.



LOWERING PLATFORM  
FIG. 46-2



RAISING PLATFORM  
FIG. 46-3

5. Lower platform to the ground (FIG. 46-4).

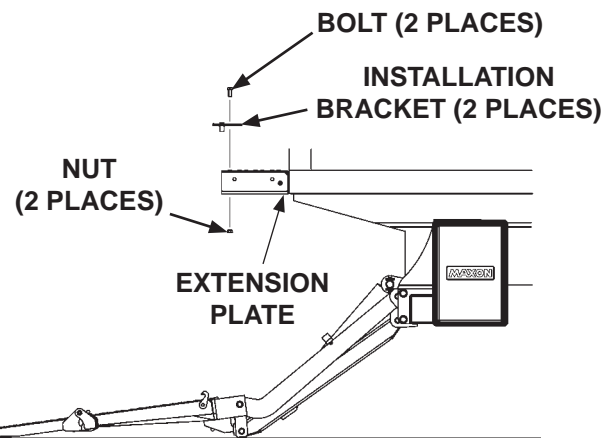

REMOVING INSTALLATION BRACKETS  
FIG. 46-4

6. Unbolt and remove the 2 installation brackets from extension plate (FIG. 46-4).

## STEP 10 - REMOVE LOCKING ANGLE AND CHECK FOR INTERFERENCE - Continued

**NOTE:** Correct any fit and interference problems before continuing with installation.

7. Raise platform to bed height (**FIG. 47-1**). There should be a 5/8" gap between the heel of platform and the extension plate (**FIG. 47-1**).

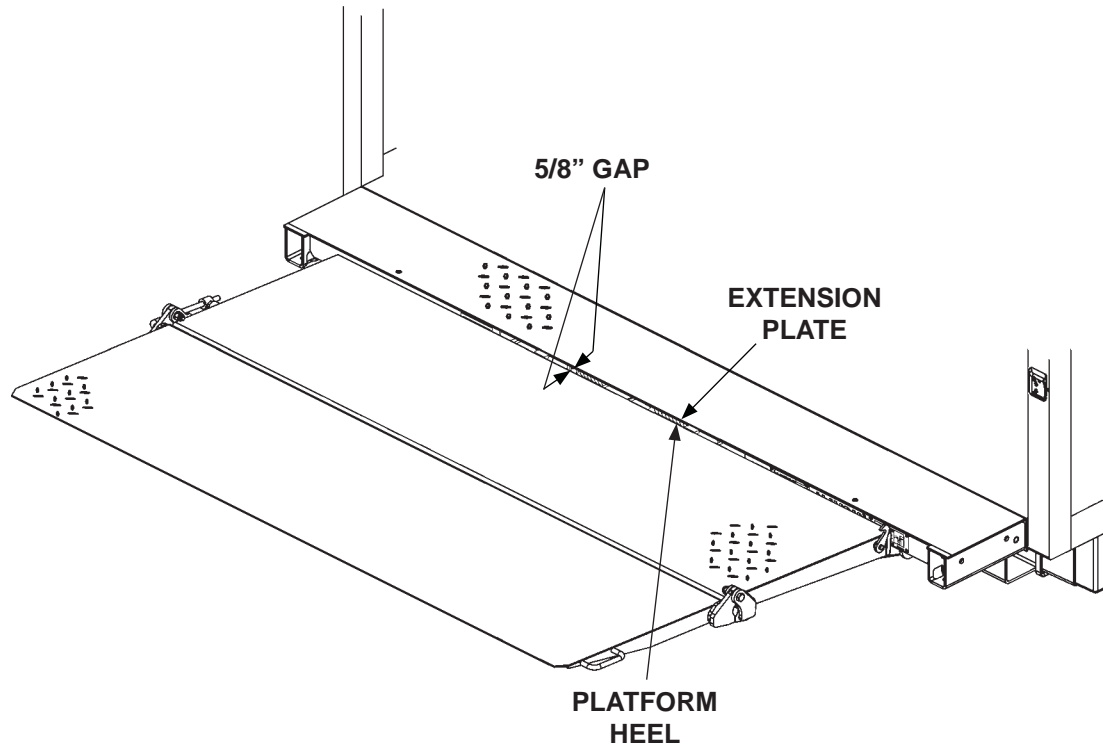

**PLATFORM AT BED LEVEL WITH 5/8" GAP  
BETWEEN HEEL & EXTENSION PLATE  
FIG. 47-1**

# STEP 10 - REMOVE LOCKING ANGLE AND CHECK FOR INTERFERENCE - Continued

**NOTE:** Correct any fit and interference problems before continuing with installation.

8. Ensure top surface of platform and extension plate are flush at the RH and LH sides of platform (**FIG. 48-1**). The allowable difference in height is  $\pm 1/8$ " maximum as shown.

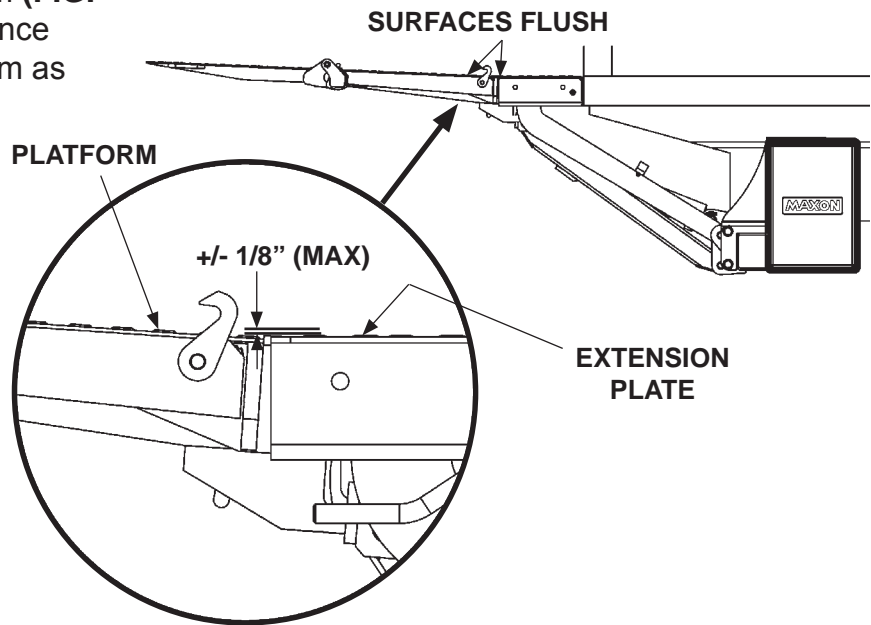

**MAXIMUM DIFFERENCE IN HEIGHT FOR TOP OF PLATFORM & EXTENSION PLATE (RH VIEW)  
FIG. 48-1**



# STEP 11 - BOLT PLATFORM OPENER TO LIFTGATE

1. Start with platform unfolded at ground level (FIG. 49-1).

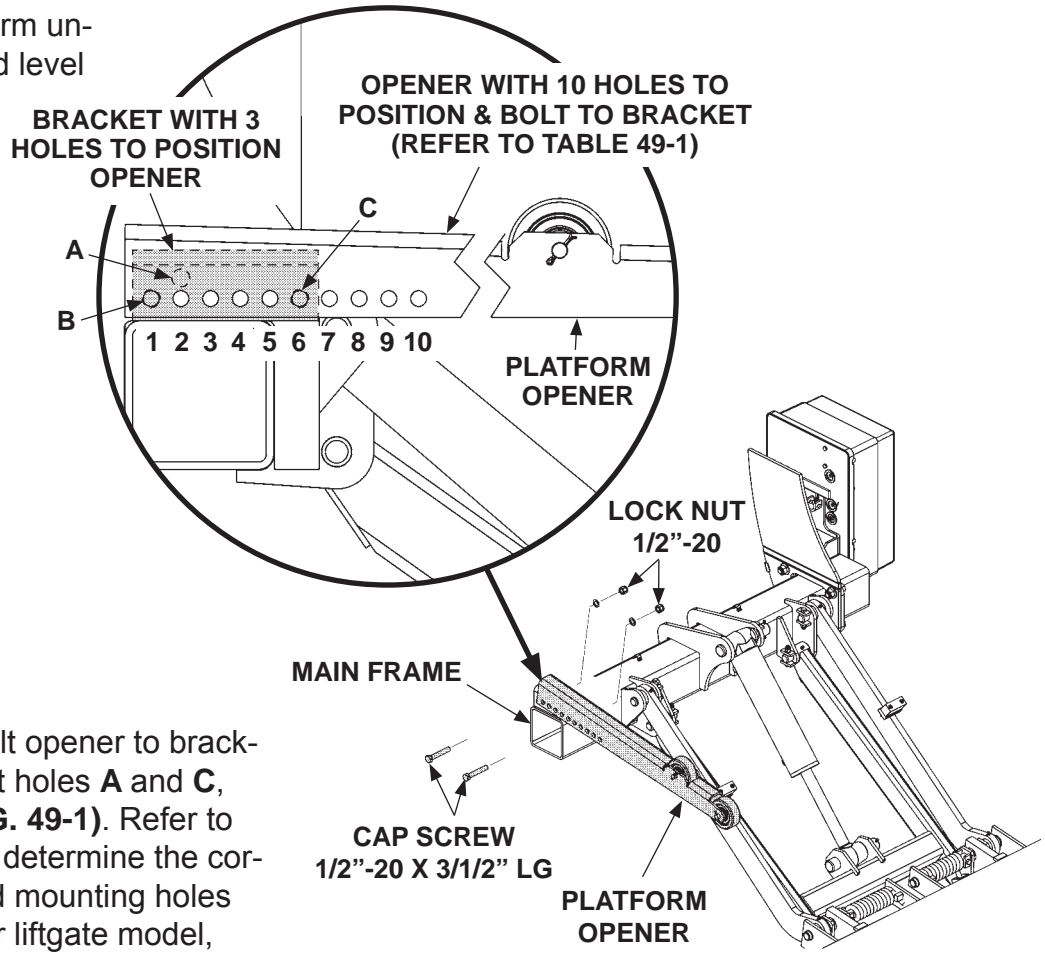

2. Position and bolt opener to bracket in 2 places at holes **A** and **C**, or **B** and **C** (FIG. 49-1). Refer to **TABLE 49-1** to determine the correct opener and mounting holes to use with your liftgate model, platform size, platform type, and vehicle bed height.

**BOLTING PLATFORM OPENER  
FIG. 49-1**

MODEL	PLATFORM	BED HEIGHT	HOLE ON OPENER ARM	HOLE ON BRACKET
TE-25/TE-30 (HIGH BED)	22"+14" STEEL	42" TO 50"	#1	B
		50" TO 54"	#2	A
	24"+24" STEEL, ALUM, OR STEEL & ALUM	42" TO 48"	#1	A
		48" TO 52"	#2	A
		52" TO 54"	#3	A
	26"+26" STEEL & ALUM, OR ALUM	42" TO 48"	#1	A
		48" TO 52"	#2	A
52" TO 54"		#3	A	
TE-25L/TE-30L (LOW BED)	22"+14" STEEL	36" TO 44"	#1	A
	24"+24" STEEL, ALUM, OR STEEL & ALUM			

**PLATFORM OPENER & BRACKET MOUNTING HOLES  
TABLE 49-1**

# STEP 11 - BOLT PLATFORM OPENER TO LIFTGATE - Continued

## ⚠ CAUTION

If there is any interference with the platform while stowing Liftgate, check for damage on bottom of platform, flipover, and the hinge in between. A damaged platform or flipover may result in personal injury and additional damage to Liftgate.

3. Fold platform and flipover against opener (**FIG. 50-1**). Platform and flipover should stay in near vertical position without falling open, .

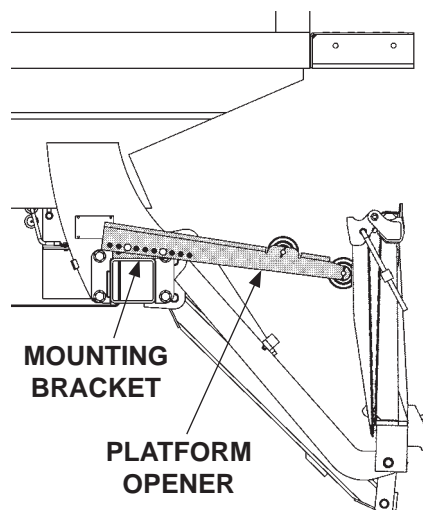

CHECKING OPENER POSITION  
FIG. 50-1

4. Stow and unstow platform several times to verify it stows and unstows correctly and there is no interference (**FIGS. 50-2 and 50-3**).

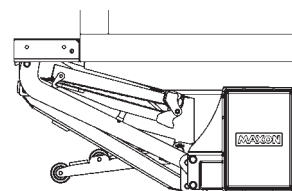

PLATFORM STOWED  
FIG. 50-2

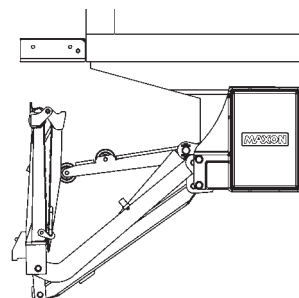

PLATFORM UNSTOWED  
FIG. 50-3

# STEP 12 - PLATFORM ADJUSTMENT (IF REQUIRED)

**NOTE:** Before doing the following procedure, make sure vehicle is parked on level ground.

1. Make sure platform is at ground level. Unfold the platform and flipover. As the platform first touches the ground, shackles and tip of flipover must touch the ground at the same time (**FIG. 51-1**). If the shackles and the tip of flipover touch the ground at the same time, raise platform to bed height. Outboard edge on top of flipover should be above bed level (**FIG. 51-2**). If indications are correct in both cases (**FIGS. 51-1 & 51-2**), Liftgate is installed correctly and no adjustment is needed. If indications are incorrect, continue with instruction 2.

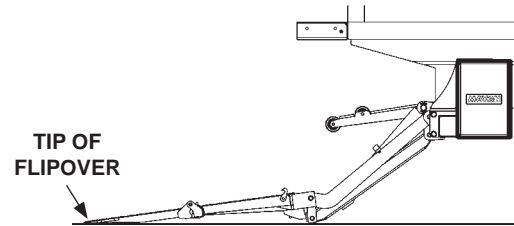

**PLATFORM & SHACKLES TOUCH GROUND**  
**FIG. 51-1**

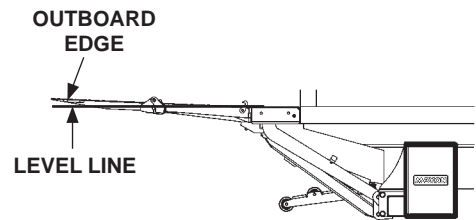

**PLATFORM EDGE ABOVE BED LEVEL**  
**FIG. 51-2**

**NOTE:** If tip of flipover touches first (**FIG. 51-3A**), do instructions 2 and 3. If the shackle touches first (see **FIG. 53-1**), skip 2 and 3 and do instructions 4 and 5.

2. Make sure platform is still at ground level. If the shackle is not touching the ground, measure and compare distance "A" (**FIG. 51-3A**) with **TABLE 51-1** to determine the correct shim. Next, mark position on shackle (**FIG. 51-3B**).

RAISE TIP OF FLIPOVER THIS DISTANCE "A"	REQUIRED SHIM THICKNESS	WELD SIZE "W"
9/16"	1/16"	1/16"
1-1/4"	1/8"	1/8"
1-15/16"	3/16"	3/16"
2-5/8"	1/4"	1/4"

**SHIMS TO RAISE TIP OF FLIPOVER**  
**TABLE 51-1**

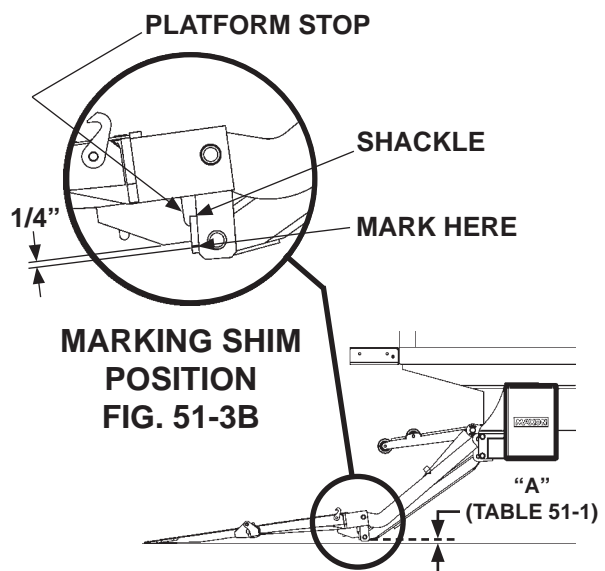

**SHACKLES DO NOT TOUCH GROUND**  
**FIG. 51-3A**

## STEP 12 - PLATFORM ADJUSTMENT (IF REQUIRED) - Continued

3. Make shims as needed (**FIG. 52-1**). Position bottom edge of shim to line up with mark on shackle (**FIG. 52-2**). Then, weld the shim to shackle as shown in **FIG. 52-2**.

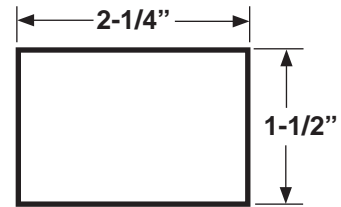

**SHIM (1/16", 1/8", 3/16", or 1/4")  
MADE FROM STEEL FLAT  
FIG. 52-1**

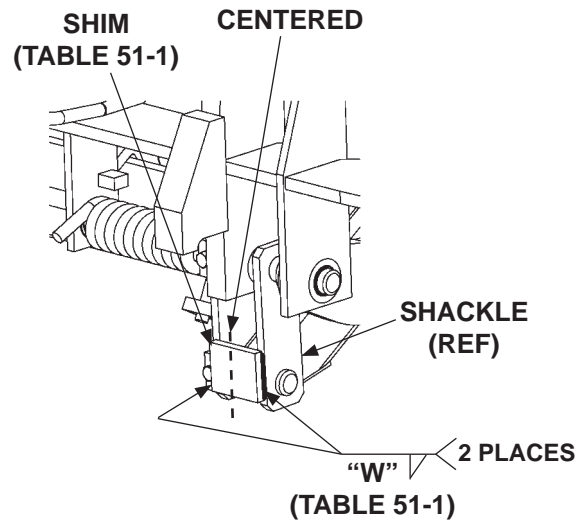

**WELDING SHIMS (RH SHACKLE SHOWN)  
FIG. 52-2**

# STEP 12 - PLATFORM ADJUSTMENT (IF REQUIRED)

## Continued

- Make sure platform is still at ground level. If the tip of flipover is not touching the ground, measure and compare distance "B" (FIG. 53-1) with TABLE 53-1 to determine how much to grind from the platform stops (FIG. 53-2).

LOWER TIP OF FLIPOVER THIS DISTANCE "B"	GRIND METAL FROM PLATFORM STOP
9/16"	1/16"
1-1/4"	1/8"
1-15/16"	3/16"
2-5/8"	1/4"

**GRIND TO LOWER TIP**  
**TABLE 53-1**

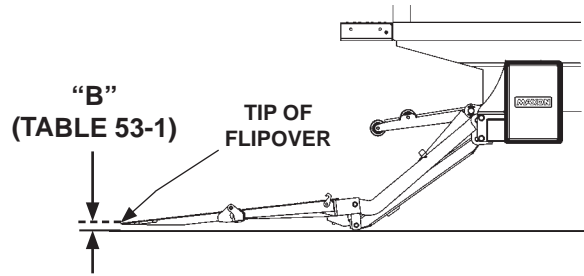

**TIP OF FLIPOVER DOES NOT TOUCH GROUND**  
**FIG. 53-1**

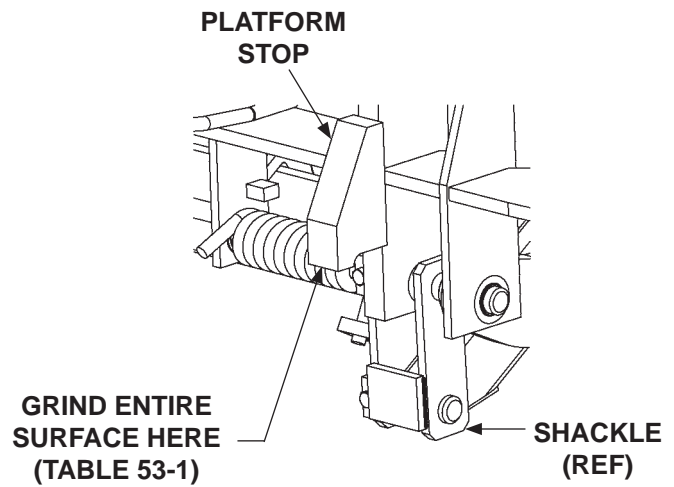

**GRINDING PLATFORM STOPS**  
**(RH SHACKLE SHOWN)**  
**FIG. 53-2**

- Grind correct amount of metal (TABLE 53-1) from platform stop as shown in FIG. 53-2.

- Raise the platform, then lower it to the ground. As the platform first touches the ground, the tip of flipover and shackle should touch at the same time as shown in FIG. 53-3.

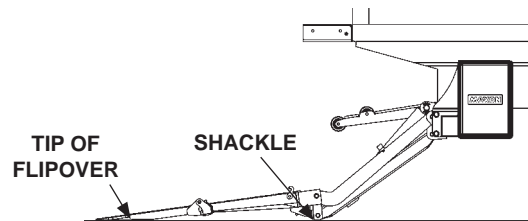

**PLATFORM & SHACKLES TOUCH GROUND**  
**FIG. 53-3**

# STEP 13 - FINISH WELDING LIFTGATE TO VEHICLE

## CAUTION

Prevent damage to hydraulic hoses. Before welding next to hydraulic hoses, protect the hoses with a heat-resistant cover such as a welding blanket.

## CAUTION

To protect the original paint system if equipped, a 3" wide area of paint must be removed from all sides of the weld area before welding.

Weld each of the two mounting plates as shown in FIGS. 54-1 or 54-2.

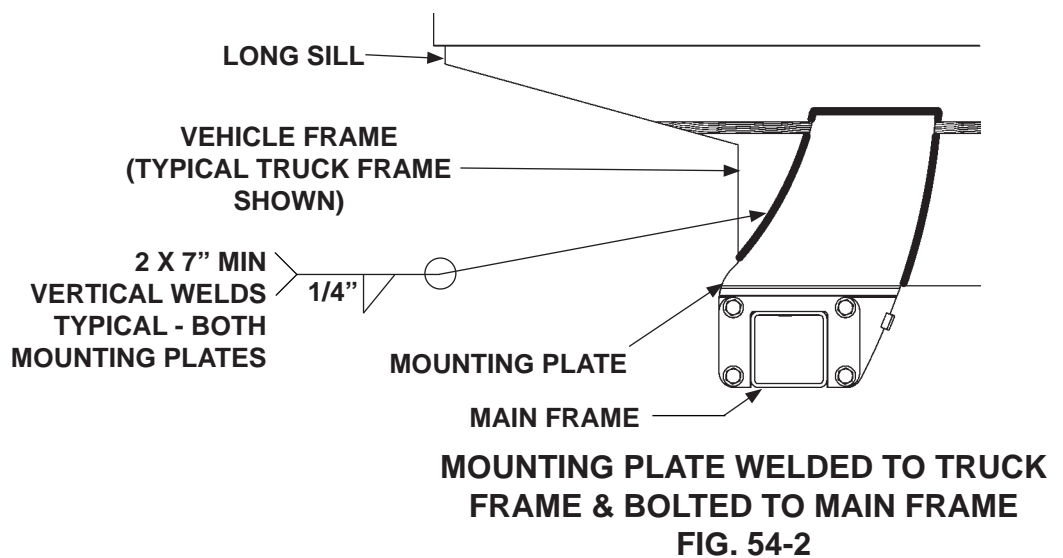
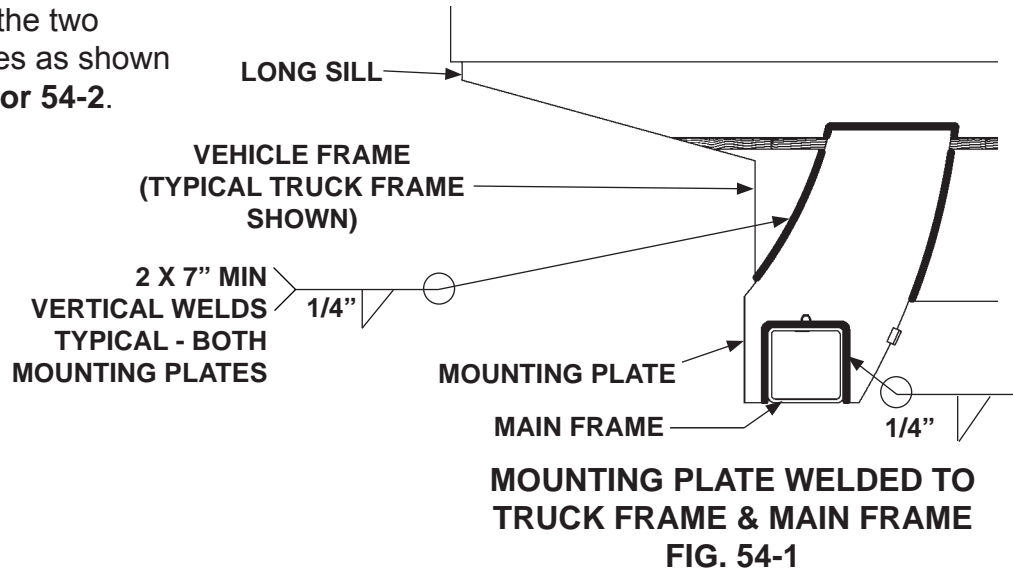

# STEP 14 - ADJUST SAFETY HOOK (IF REQUIRED)

## CHECK SAFETY HOOK FUNCTION

1. When raising platform to stowed position, listen for sound of **safety hook** engaging **platform loop**.
2. When the Liftgate is stowed, see if **platform loop** is seated in the **safety hook** as shown in **FIG. 55-1**.

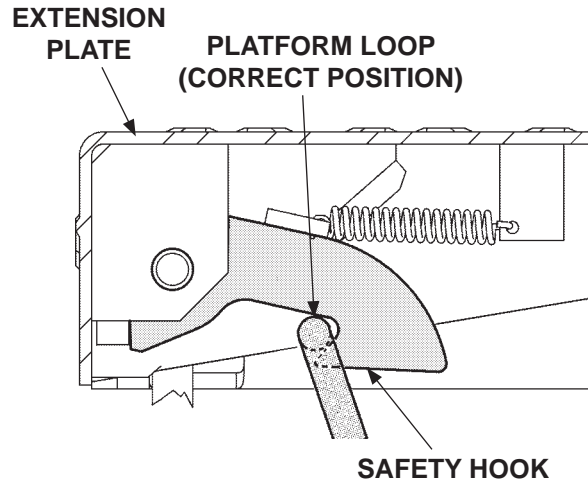

**PLATFORM LOOP SHOWN HOOKED  
IN CORRECT POSITION  
FIG. 55-1**

## LOOP ADJUSTMENT

1. If the safety hook is not positioned correctly (**FIG. 55-2**), lower platform enough to access the safety hook. (**See Operation Manual for instructions to lower the platform.**)
2. Adjust by bending the platform loop so it seats correctly in the hook as shown in **FIG. 55-2**.
3. Stow the platform and check for correct safety hook position (**FIG. 55-2**). Repeat adjustment if required.

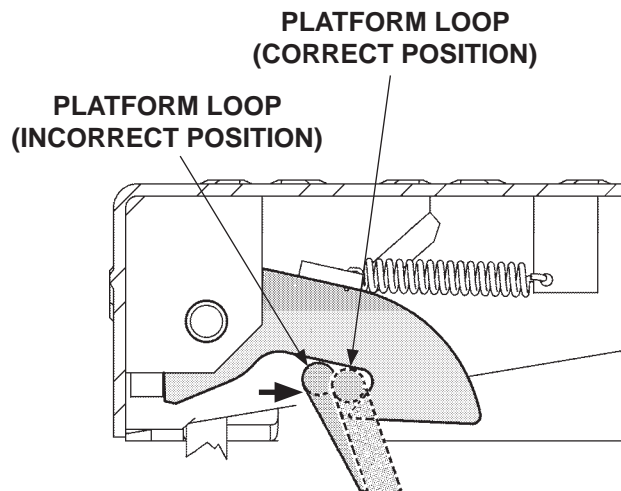

**PLATFORM LOOP SHOWN HOOKED  
INCORRECTLY  
FIG. 55-2**

## STEP 15 - VEHICLE TAILLIGHT POSITIONING (IF REQUIRED)

**NOTE:** Positions are based on using taillights of 6-3/4" height by 5-3/4" width. Larger taillights may interfere with Liftgate. Taillights and attaching hardware are not provided with the Liftgate.

Position taillights as shown (FIGS. 56-1, 56-2 & 56-3).

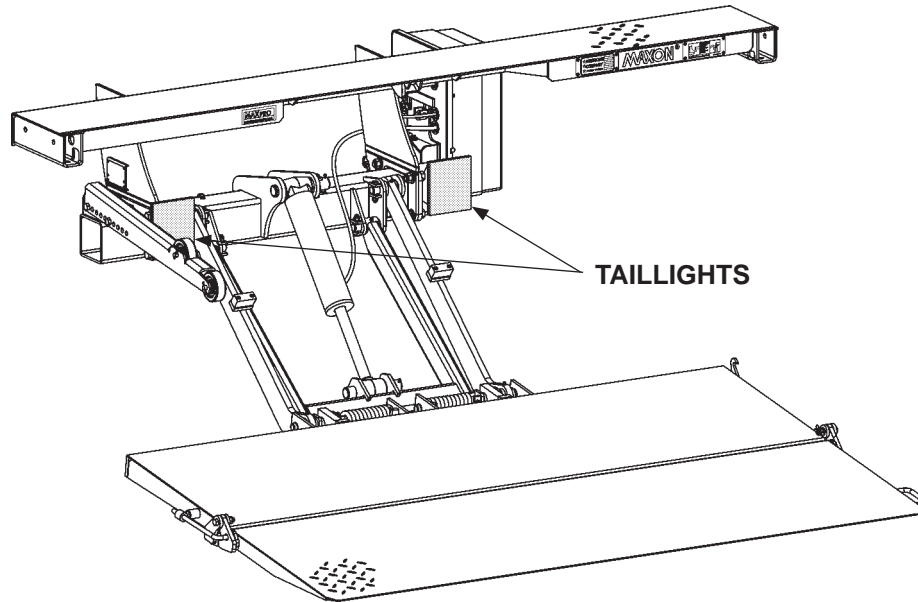
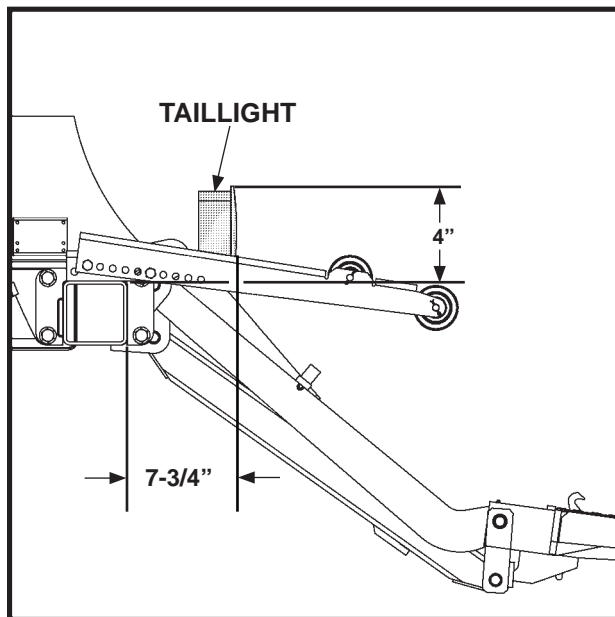
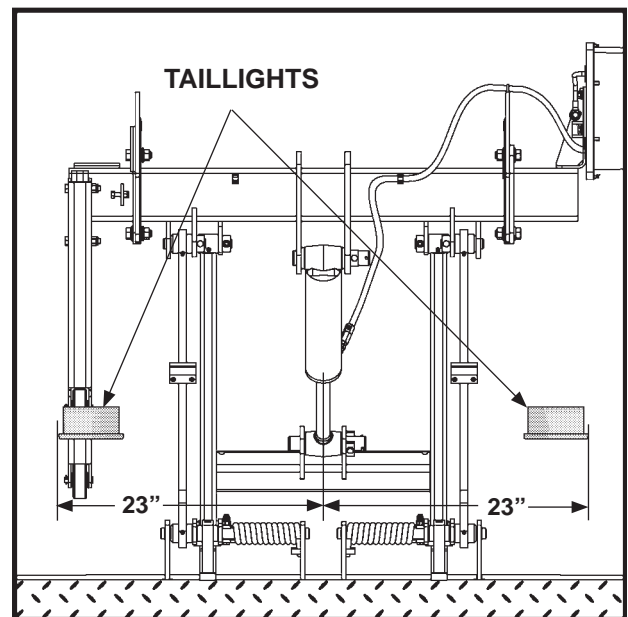

FIG. 56-1



**TAILLIGHT POSITIONS  
(LEFT HAND SIDE VIEW)  
FIG. 56-2**



**TAILLIGHT HORIZONTAL SPACING,  
TOP VIEW  
FIG. 56-3**



# ATTACH DECALS

**NOTE:** Ensure there is no residue, dirt or corrosion where decals are attached. If necessary, clean surface before attaching decals.

**NOTE:** Preferred decal layout is shown, Decals on the Liftgate are attached at the factory. If vehicle does not permit this layout, decals in the manual and decal kit must be applied so that they are easily visible when approaching vehicle to operate Liftgate. Use good common sense when locating these decals on vehicle.

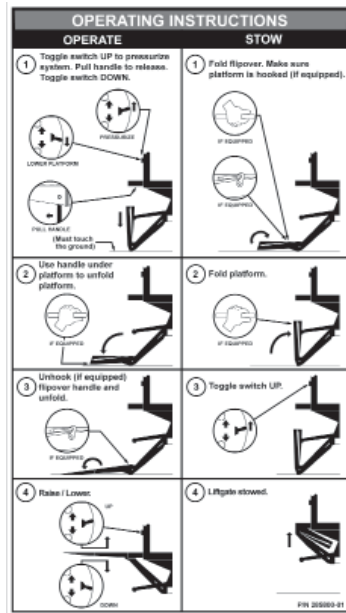

**INSTRUCTION DECAL**  
P/N 285800-01

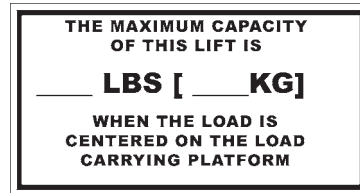

**CAPACITY DECAL**  
(REFER TO TABLE 58-1)

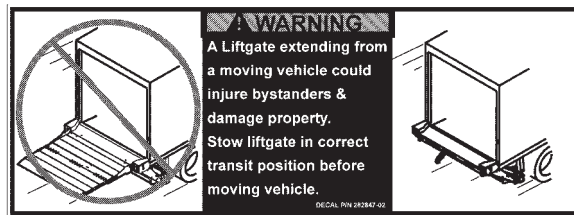

**STOW WARNING DECAL**  
P/N 282847-02

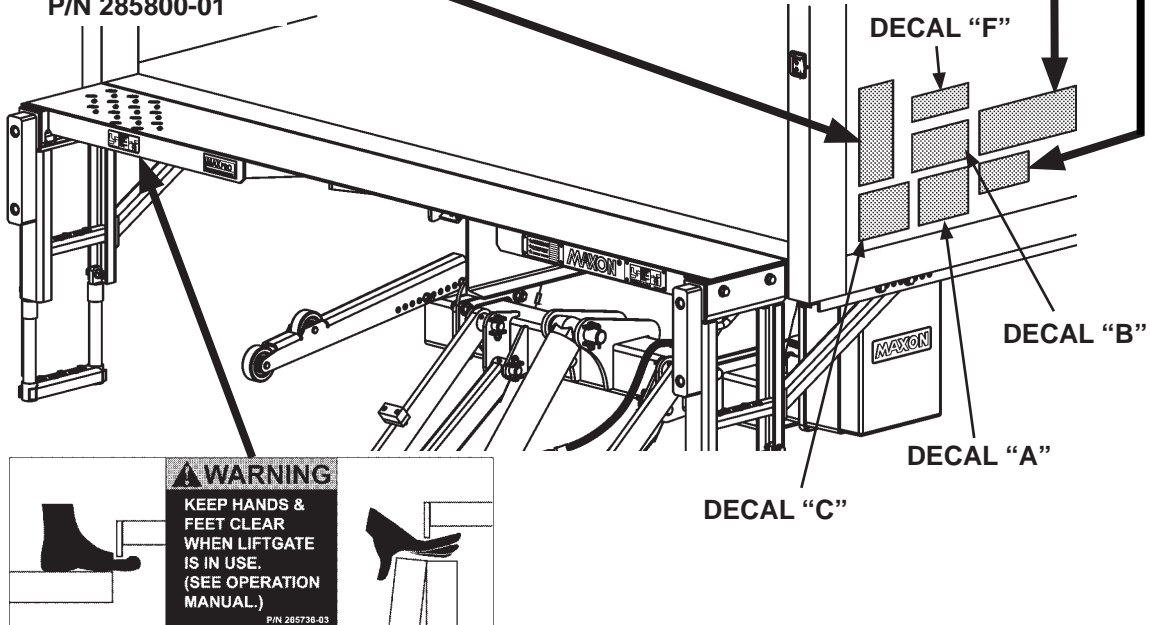

**WARNING DECAL**  
P/N 265736-03

**FIG. 57-1**

# ATTACH DECALS - Continued

**CAUTION**

**Always stand clear of platform area.**

P/N 282522-01 (F)

**WARNING**

**Read this information carefully.**

- Improper operation of this Liftgate can result in serious personal injury. If you do not have a copy of the operating instructions, please obtain them from your employer, distributor, or lessor before you attempt to operate Liftgate.
- If there are signs of improper maintenance, damage to vital parts, or slippery platform surface, do not use the Liftgate until these problems have been corrected.
- If you are using a pallet jack, be sure it can be maneuvered safely.
- Do not operate a forklift on the platform.
- Do not allow any part of yours or your helper's body to be placed under, within, or around any portion of the moving Liftgate, or its mechanisms, or in a position that would trap them between the platform and the ground or truck when the Liftgate is operated.
- If a helper is riding the platform with you, make sure you are both doing so safely and that you are not in danger of coming in contact with any moving or potentially moving obstacles.
- **USE GOOD COMMON SENSE.**
- If load appears to be unsafe, do not lift or lower it.

For a free copy of other manuals that pertain to this model Liftgate, please visit our website at [www.maxonlift.com](http://www.maxonlift.com) or call Customer Service at (800) 227-4116

P/N 282522-01 (C)

**SAFETY INSTRUCTIONS**

**Read all decals and operation manual before operating liftgate.**

1. Do not use liftgate unless you have been properly instructed and have read, and are familiar with, the operating instructions.
2. Be certain vehicle is properly and securely braked before using the liftgate.
3. Always inspect this liftgate for maintenance or damage before using it. Do not use liftgate if it shows any sign of damage or improper maintenance.
4. Do not overload
5. Make certain the area in which the platform will open and close is clear before opening or closing the platform.
6. Make certain platform area, including the area in which loads may fall from platform, is clear before and at all times during operation of liftgate.
7. This liftgate is intended for loading and unloading of cargo only. Do not use this liftgate for anything but its intended use.

P/N 282522-01 (A)

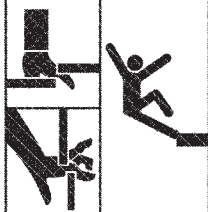

**WARNING**

**Liftgate hazards can result in crushing or falling.**

**Keep hands and feet clear of pinch points.**

**If riding liftgate, make sure load is stable and footing is solid.**

P/N 282522-01 (B)

**Read and understand all instructions and WARNINGS before use.**

**DECAL SHEET P/N 282522-01**

**FIG. 58-1**

MODEL	DECAL P/N	CAPACITY
TE-25	220382	2500 POUNDS [1134 KG]
TE-30	220388	3000 POUNDS [1360 KG]

**CAPACITY DECALS  
TABLE 58-1**

## TOUCHUP PAINTED OR GALVANIZED FINISH

### CAUTION

Damaged cylinder seals and contaminated hydraulic fluid can result from painting the polished portion of the cylinder rod. To prevent damage, protect the exposed polished portion of the cylinder rod while painting.

- If bare metal or primer is exposed on the painted portions of the Liftgate, touch up the paint. To maintain the protection provided by the original paint system, **MAXON** recommends aluminum primer touchup paint.
- If bare metal is exposed on galvanized portions of the Liftgate, touch up the galvanized finish. To maintain the protection provided by the original galvanized finish, **MAXON** recommends cold galvanize spray.

# SYSTEM DIAGRAMS

## PUMP, MOTOR & SOLENOID OPERATION - GRAVITY DOWN

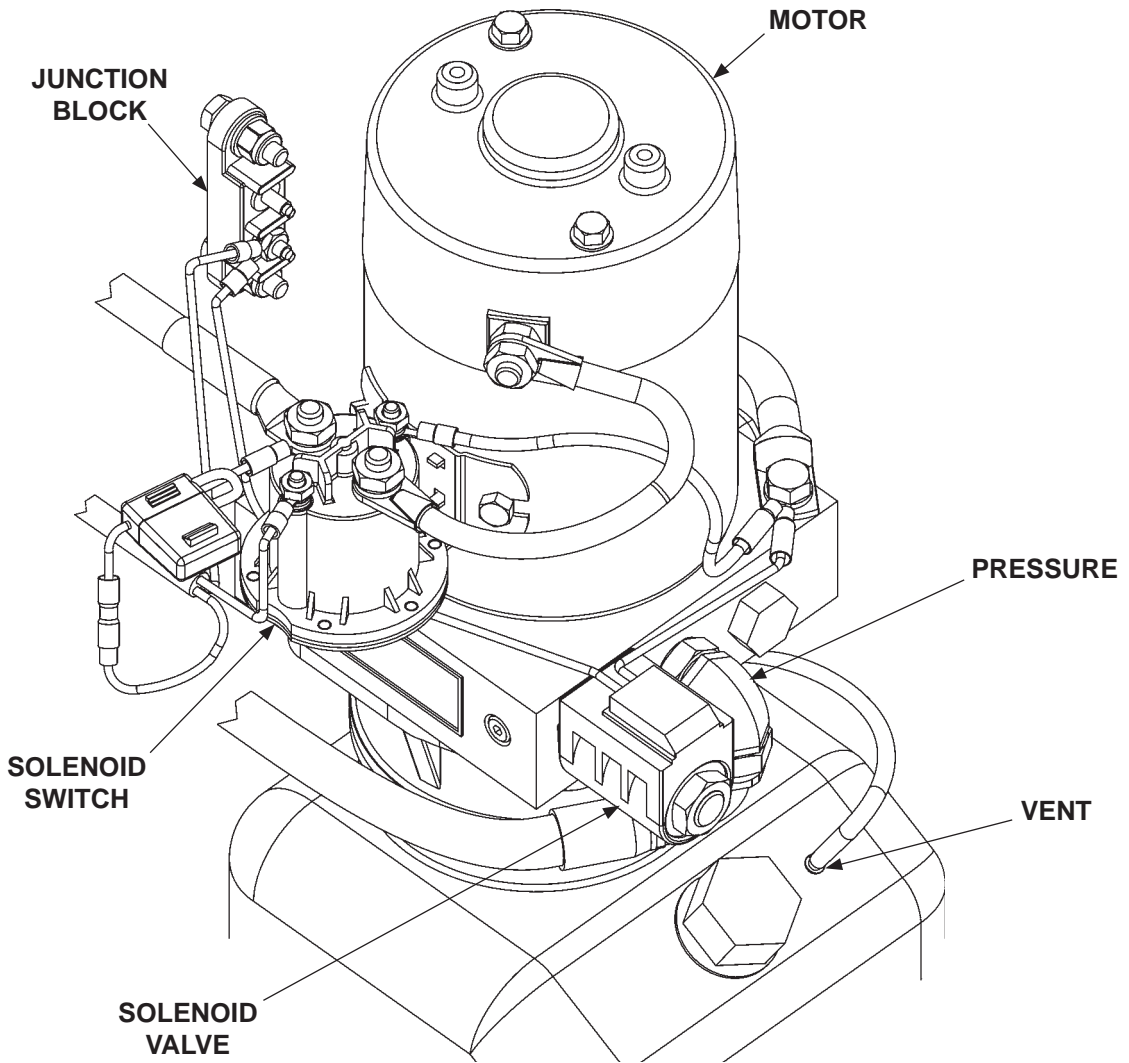

GRAVITY DOWN PUMP MOTOR & SOLENOID SWITCH OPERATION			
LIFTGATE FUNCTION	PORT	SOLENOID SWITCH OPERATION ✓ ( MEANS ENERGIZED)	
		MOTOR	SOLENOID VALVE
RAISE	PRESSURE	✓	-
LOWER	VENT	-	✓
REFER TO VALVES SHOWN ON HYDRAULIC SCHEMATIC			

**TABLE 60-1**

# SYSTEM DIAGRAMS

## PUMP, MOTOR & SOLENOID OPERATION - POWER DOWN

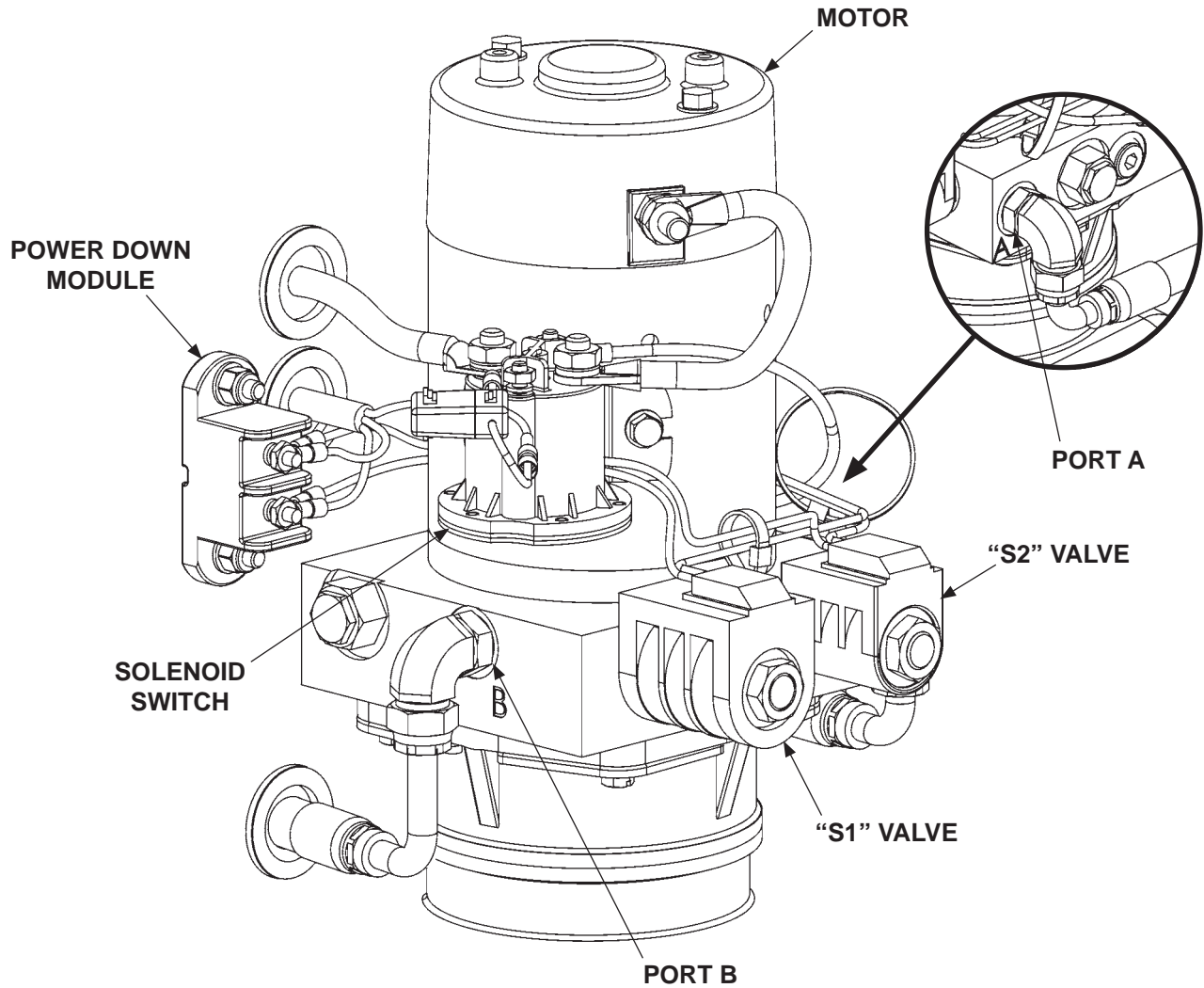

POWER DOWN PUMP MOTOR & SOLENOID SWITCH OPERATION					
LIFTGATE FUNCTION	PORT	SOLENOID SWITCH OPERATION (✓ MEANS ENERGIZED)			
		MOTOR	VALVE "S2"	VALVE "S1"	POWER DOWN MODULE
RAISE	A	✓	-	✓	-
LOWER	B	✓	✓	-	✓
REFER TO VALVES SHOWN ON HYDRAULIC SCHEMATIC					

TABLE 61-1

# HYDRAULIC SYSTEM DIAGRAMS

## HYDRAULIC SCHEMATIC (GRAVITY DOWN)

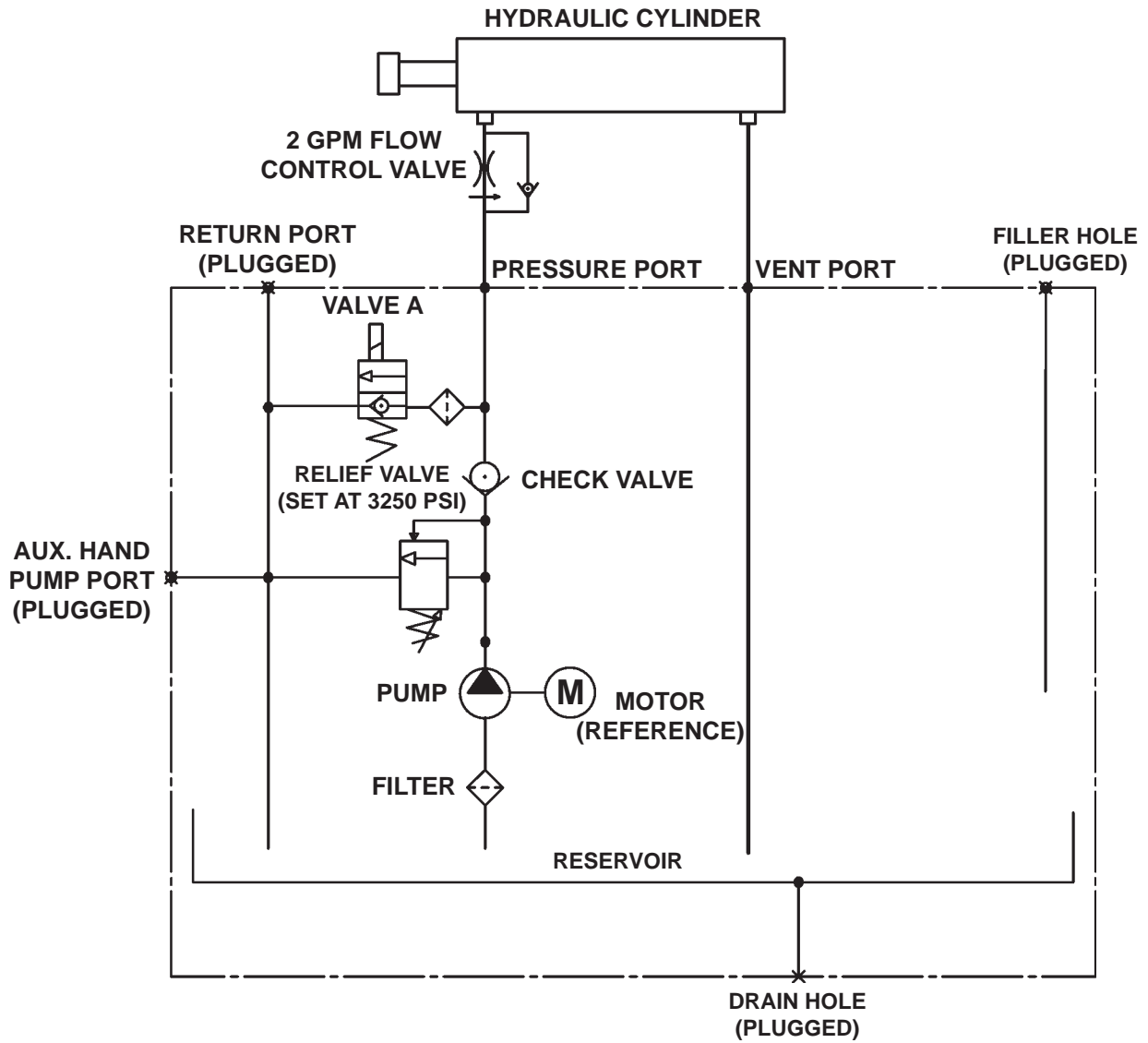

FIG. 62-1

# HYDRAULIC SYSTEM DIAGRAMS

## HYDRAULIC SCHEMATIC (POWER DOWN)

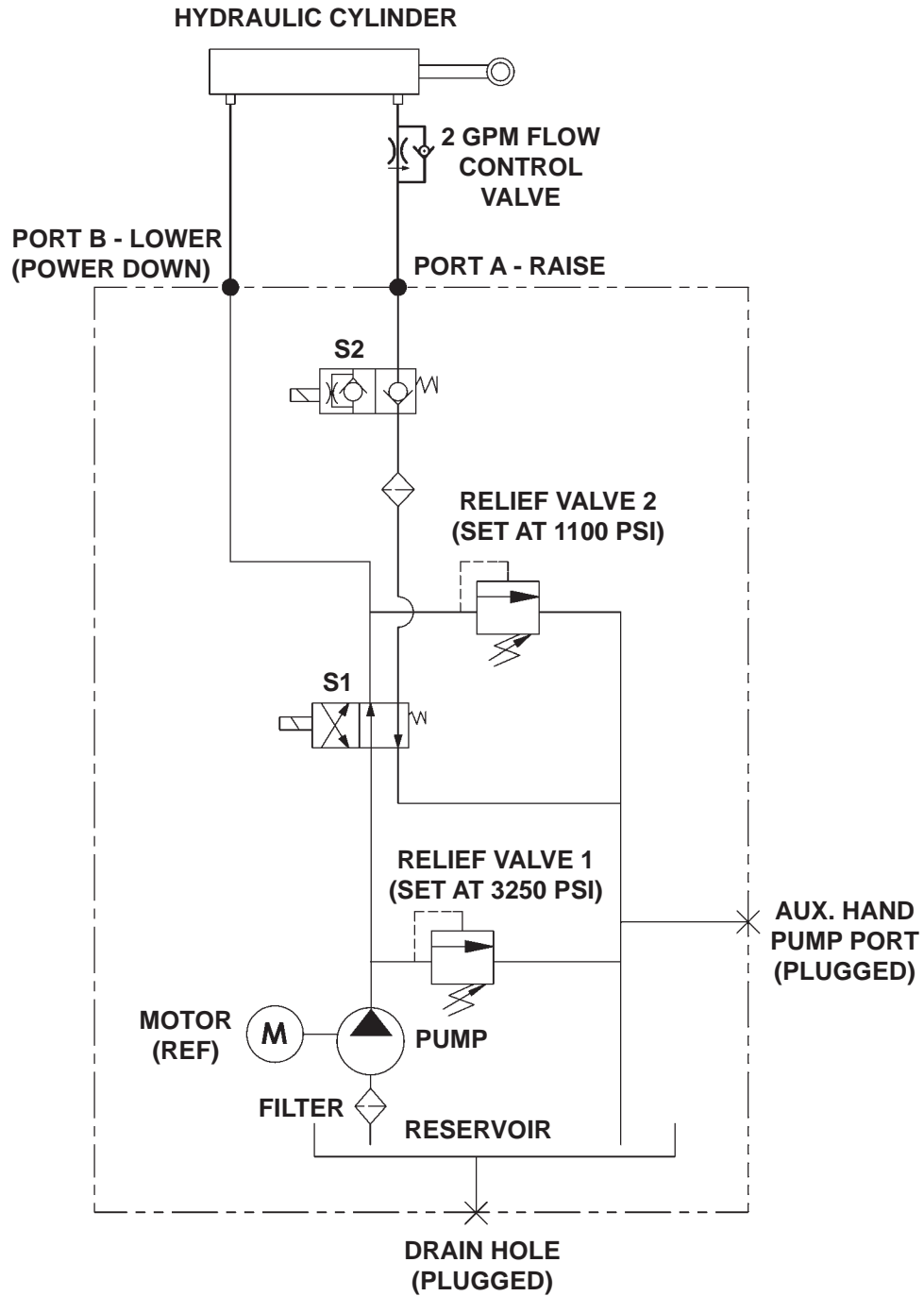

FIG. 63-1

# ELECTRICAL SYSTEM DIAGRAMS

## ELECTRICAL SCHEMATIC (GRAVITY DOWN)

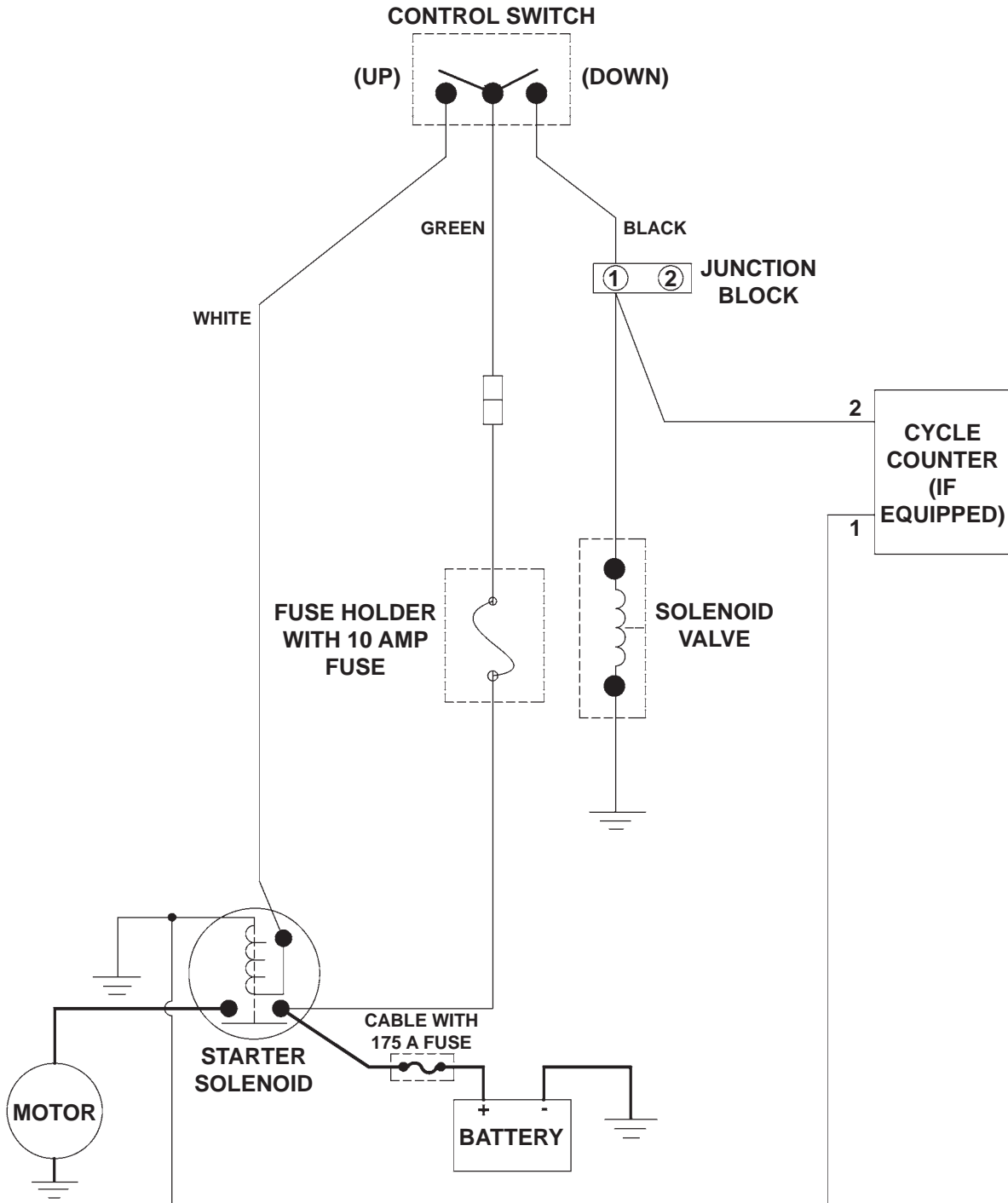

FIG. 64-1



# ELECTRICAL SYSTEM DIAGRAMS

## ELECTRICAL SCHEMATIC (POWER DOWN)

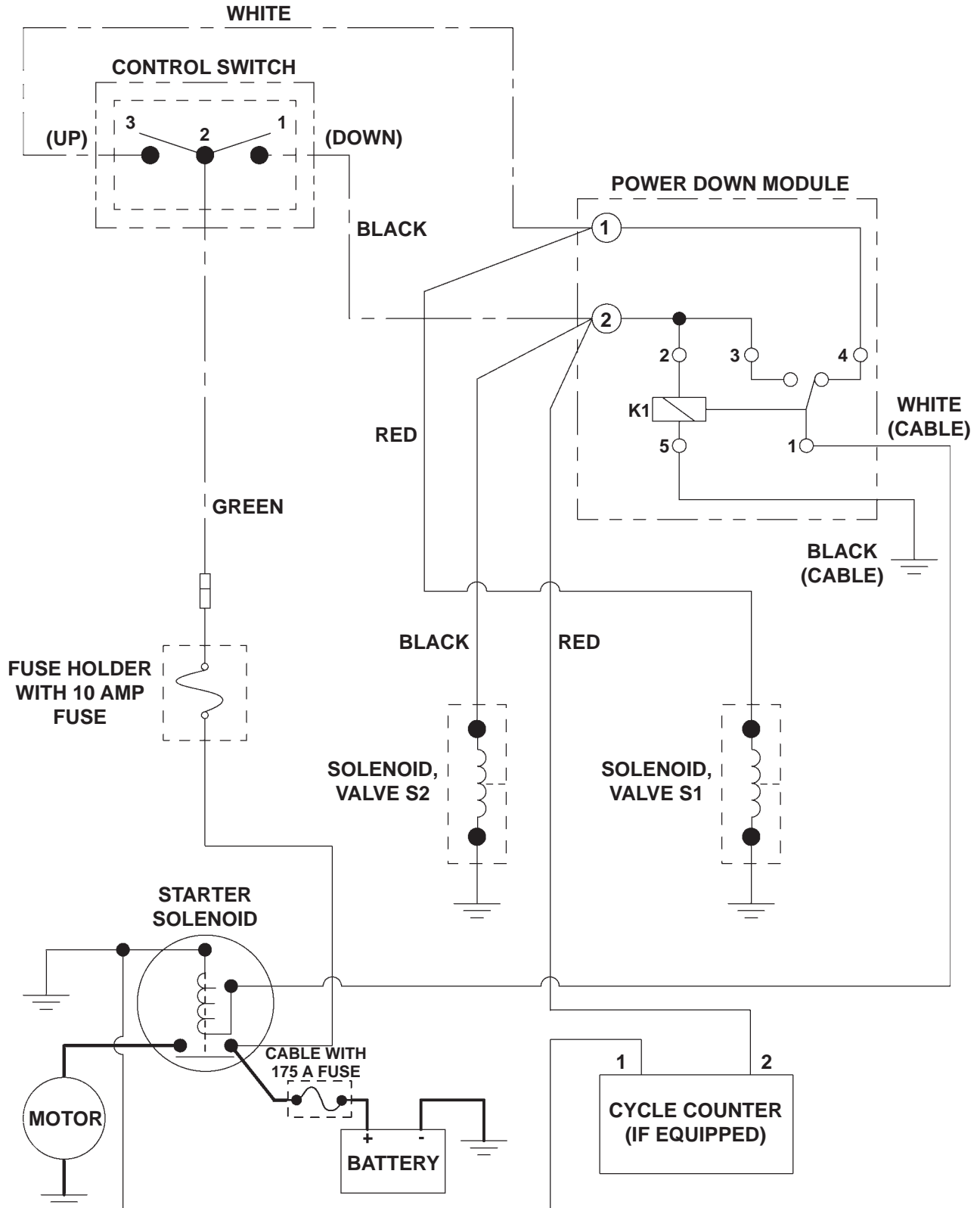

FIG. 65-1

## SYSTEM DIAGRAMS

### TE-25/TE-30 ELECTRICAL VALUES

Solenoid Switch	12V	24V
Coil Resistance:	5.4Ω @70°F. ±15%	20.1Ω @70°F. ±15%
Ampere:	2.2A	1.2A
Coil terminal torque: <b>10-15 lb-in</b> max.		
Contact terminal torque: <b>30-35 lb-in</b> max.		
<b>Solenoid Valves (A, S1, &amp; S2)</b>		
Coil Resistance:	6.6Ω @ 70°F. ±15%	26.7Ω @ 70°F. ±15%
Ampere:	1.8A	0.9A
Coil terminal torque: <b>15-45 lb-in</b> max.		
Valve cartridge torque: <b>25-30 lb-ft</b> max.		
Coil nut torque: <b>15-45 lb-in</b>		
<b>Solenoid Lock Valve</b>		
Coil Resistance:	8.0Ω @ 70°F. ±15%	30Ω @ 70°F. ±15%
Ampere:	1.5A	0.8A
Coil terminal torque: <b>3-4.5 lb-ft</b> max.		
Valve cartridge torque: <b>18.5-22 lb-ft</b> max.		
<b>Ground Cable</b>		
Cap Screw Torque: <b>24 lb-ft</b> max.		

TABLE 66-1

## OPTIONS OPTIONAL LIFTGATE COMPONENTS

MISCELLANEOUS KITS	PART NO.	GD	PD
TRAFFIC CONES	268893-01	X	X
RELOCATE PUMP MTG KIT, GD TUK-A-WAY	297619-01	X	
RELOCATE PUMP MTG KIT, GD TUK-A-WAY, GALVANIZED	297619-01G	X	
RELOCATE PUMP MTG KIT, PD TUK-A-WAY	297619-02		X
RELOCATE PUMP MTG KIT, PD TUK-A-WAY, GALVANIZED	297619-02G		X
EXTENSION PLATE HARDWARE, 96" & 102" LG INSTALLATIONS	283257-02	X	X
MOUNTING PLATES, TE, 42-1/4" INSIDE	298385-01	X	X
<b>MECHANICAL KITS</b>			
102" EXTENSION, 11" EXT. PLATE (1/4" THICK EXTENSION PLATES ONLY)	287095-01	X	X
102" EXTENSION, GALVANIZED, 11" EXT. PLATE (1/4" THICK EXT. PLATES ONLY)	287095-01G	X	X
<b>ELECTRICAL KITS</b>			
IN CAB ON-OFF SWITCH	250477	X	X
DUAL CONTROL, TUK-A-WAY	297115-01	X	X
STREET SIDE CONTROL, TUK-A-WAY	297116-01	X	X
HAND HELD CONTROL KIT	280570-07	X	X
HAND HELD CONTROL KIT, 120" LG., CURB SIDE MOUNT	263260-13	X	X
HAND HELD CONTROL KIT, 240" LG., STREET SIDE MOUNT	263260-14	X	X
FRAME MOUNTING BRACKET FOR 2 OVAL LIGHTS	282372-01	X	X
FRAME MOUNTING BRACKET FOR 2 OVAL LIGHTS, GALVANIZED	282372-01G	X	X
<b>HAND PUMP OPTIONS</b>			
KIT, HAND PUMP, TUK-A-WAY	297117-01	X	

**MAXON**<sup>®</sup> 11921 Slauson Ave. Santa Fe Springs, CA. 90670 (800) 227-4116 FAX (888) 771-7713

## OPTIONS OPTIONAL LIFTGATE COMPONENTS

HIGH BED STEP OPTIONS (42" TO 54" BED HEIGHT, 30" OVERALL STEP HEIGHT)			
	PART NO.	GD	PD
<b>PAINTED DUAL STEP KITS WITH BUMPER</b>			
DUAL STEPS, 14" RUBBER BUMPERS	288705-01	X	X
DUAL STEPS, 13.5" RUBBER BUMPERS	288705-02	X	X
DUAL FLEX STEPS 14" RBR BUMPERS WITH FLEXIBLE WIRE ROPE LOWER STEP & 14" LG. RUBBER BUMPER	288705-21	X	X
DUAL FLEX STEPS WITH FLEXIBLE WIRE ROPE LOWER STEP & 13.5" LG. RUBBER BUMPER	288705-22	X	X
DUAL STEPS W/ BRACKET FOR LIGHT AND 14" RUBBER BUMPERS	288705-31	X	X
DUAL STEPS W/ BRACKET FOR LIGHT AND 13.5" PLASTIC BUMPERS	288705-32	X	X
<b>PAINTED DUAL STEPS WITH BUMPERS AND NO STEPS ON STREET SIDE</b>			
DUAL STEPS, STREETSIDE, NO STEPS, 14" BUMPER	288705-03	X	X
DUAL STEPS, STREETSIDE, NO STEPS, 13.5" BUMPER	288705-04	X	X
DUAL FLEX STEPS, STREETSIDE, NO STEPS, 14" BUMPER	288705-23	X	X
DUAL FLEX STEPS, STREETSIDE, NO STEPS, 13.5" BUMPER	288705-24	X	X
DUAL STEPS, W/LIGHT STREETSIDE, NO STEPS, 14" BUMPER	288705-33	X	X
DUAL STEPS, W/LIGHT STREETSIDE, NO STEPS, 13.5" BUMPER	288705-34	X	X
<b>PAINTED DUAL STEPS WITHOUT BUMPERS</b>			
DUAL STEPS, NO BUMPERS	288705-05	X	X
DUAL STEPS, STREETSIDE NO STEPS, NO BUMPERS	288705-06	X	X
DUAL FLEX STEPS, NO BUMPERS	288705-25	X	X
DUAL FLEX STEPS, STREETSIDE, NO STEPS, NO BUMPERS	288705-26	X	X
DUAL STEPS W/LIGHT, NO BUMPERS	288705-35	X	X
DUAL STEPS W/LIGHT, STREETSIDE, NO STEPS, NO BUMPER	288705-36	X	X
<b>GALVANIZED DUAL STEP KITS WITH BUMPERS</b>			
DUAL STEPS, 14" RUBBER BUMPERS	288705-01G	X	X
DUAL STEPS, 13.5" PLASTIC BUMPERS	288705-02G	X	X
DUAL FLEX STEPS 14" RUBBER BUMPERS	288705-21G	X	X
DUAL FLEX STEPS 13.5" PLASTIC BUMPERS	288705-22G	X	X
DUAL FLEX STEPS W/LIGHT, 14" RUBBER BUMPERS	288705-31G	X	X
DUAL FLEX STEPS W/LIGHT, 13.5" PLASTIC BUMPERS	288705-32G	X	X
<b>GALVANIZED DUAL STEPS WITH BUMPERS AND NO STEPS STREET SIDE</b>			
DUAL STEP KIT, STREETSIDE, NO STEPS, 14" RUBBER BUMPER	288705-03G	X	X
DUAL STEP KIT, STREETSIDE, NO STEPS, 13.5" BUMPER	288705-04G	X	X
DUAL FLEX STEP KIT, STREETSIDE, NO STEPS, 14" RUBBER BUMPERS	288705-23G	X	X
DUAL FLEX STEP KIT, STREETSIDE, NO STEPS, 13.5" RUBBER BUMPERS	288705-24G	X	X
DUAL STEPS W/LIGHT, STREETSIDE, NO STEPS, 14" RUBBER BUMPERS	288705-33G	X	X
DUAL STEPS W/LIGHT, STREETSIDE, NO STEPS, 13.5" RUBBER BUMPERS	288705-34G	X	X
<b>GALVANIZED DUAL STEPS WITHOUT BUMPERS</b>			
DUAL STEPS, NO BUMPERS	288705-05G	X	X
DUAL STEPS, STREETSIDE, NO STEPS, NO BUMPERS	288705-06G	X	X
DUAL FLEX STEPS, NO BUMPERS, GALVANIZED	288705-25G	X	X
DUAL FLEX STEPS, STREETSIDE, NO STEPS, NO BUMPERS	288705-26G	X	X
DUAL STEPS W/LIGHT, NO BUMPERS	288705-35G	X	X
DUAL STEPS W/LIGHT, STREETSIDE, NO STEPS, NO BUMPER, GALVANIZED	288705-36G	X	X

**MAXON**<sup>®</sup> 11921 Slauson Ave. Santa Fe Springs, CA. 90670 (800) 227-4116 FAX (888) 771-7713

## OPTIONS OPTIONAL LIFTGATE COMPONENTS

<b>BUMPERS KIT</b>			
RUBBER BUMPER KIT, 14" BUMPERS (2.5"W X 3"H X 14" LG)	288706-01	X	X
RUBBER BUMPER KIT, 13.5" PLASTIC BUMPERS (2.9"W X 1.5"H X 13.5" LG)	288707-01	X	X
<b>LOW BED STEP OPTIONS (36" TO 44" BED HEIGHT, 21" OVERALL STEP HEIGHT)</b>			
<b>PAINTED SINGLE STEPS WITH BUMPERS</b>			
SINGLE STEPS, 14" RUBBER BUMPERS	288705-11	X	X
SINGLE STEPS, 13.5" PLASTIC BUMPERS	288705-12	X	X
<b>PAINTED SINGLE STEPS WITH BUMPERS NO STEPS ON STREET SIDE</b>			
SINGLE STEPS, STREETSIDE NO STEPS, 14" RUBBER BUMPERS	288705-13	X	X
SINGLE STEPS, STREETSIDE NO STEPS, 13.5" PE BUMPERS	288705-14	X	X
<b>PAINTED SINGLE STEPS WITHOUT BUMPERS</b>			
SINGLE STEP KIT, NO BUMPERS	288705-15	X	X
SINGLE STEP KIT, STREETSIDE, NO STEPS, NO BUMPERS	288705-16	X	X
<b>GALVANIZED SINGLE STEPS W/BUMPERS</b>			
SINGLE STEP KIT, 14" RUBBER BUMPERS	288705-11G	X	X
SINGLE STEP KIT, 13.5" PE BUMPERS	288705-12G	X	X
<b>GALVANIZED SINGLE STEPS WITH BUMPERS NO STEPS ON STREET SIDE</b>			
SINGLE STEP KIT, STREETSIDE, NO STEPS, 14" RUBBER BUMPERS	288705-13G	X	X
SINGLE STEP KIT, STREETSIDE, NO STEPS, 13.5" PE BUMPERS	288705-14G	X	X
<b>GALVANIZED SINGLE STEPS WITHOUT BUMPERS</b>			
SINGLE STEPS WITH NO BUMPERS	288705-15G	X	X
SINGLE STEPS, STREETSIDE, NO STEPS, NO BUMPERS	288705-16G	X	X
<b>PAINTED STEPS WITHOUT BUMPERS</b>			
DOCK BUMPER STEP	251416	X	X
DOCK BUMPER, RUBBER	203410	X	X

**MAXON**<sup>®</sup> 11921 Slauson Ave. Santa Fe Springs, CA. 90670 (800) 227-4116 FAX (888) 771-7713

