

INSTALLATION INSTRUCTIONS 2 STEP DOCK BUMPER # 251416

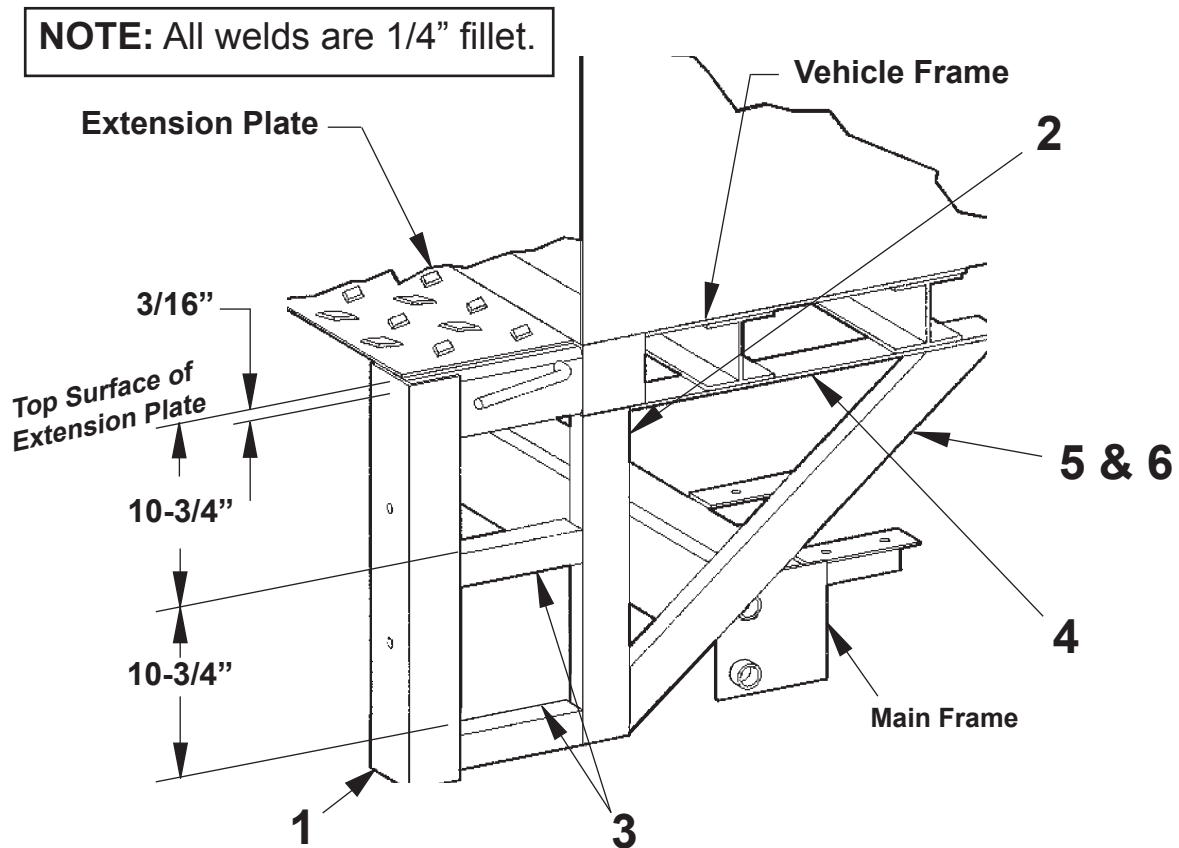

1. Weld Item 1 (P/N 226856) to each corner of extension plate.
2. Weld Item 2 (P/N 251340) under body, flush with rear surface as shown.
3. Weld Item 3 (P/N 253987) bottom step to Item 1 & 2. Weld second step, Item 3 (P/N 253987) to Item 1 & 2.
4. Weld Item 4 (P/N 263324) to underside of body cross members.
5. Weld Items 5 & 6 (P/N 252701-01 LH & P/N 252701-02 RH) to Item 2 & 4. Cut as required.

INSTALLATION INSTRUCTIONS 2 STEP DOCK BUMPER # 251416-100

NOTE: All welds are 1/4" fillet.

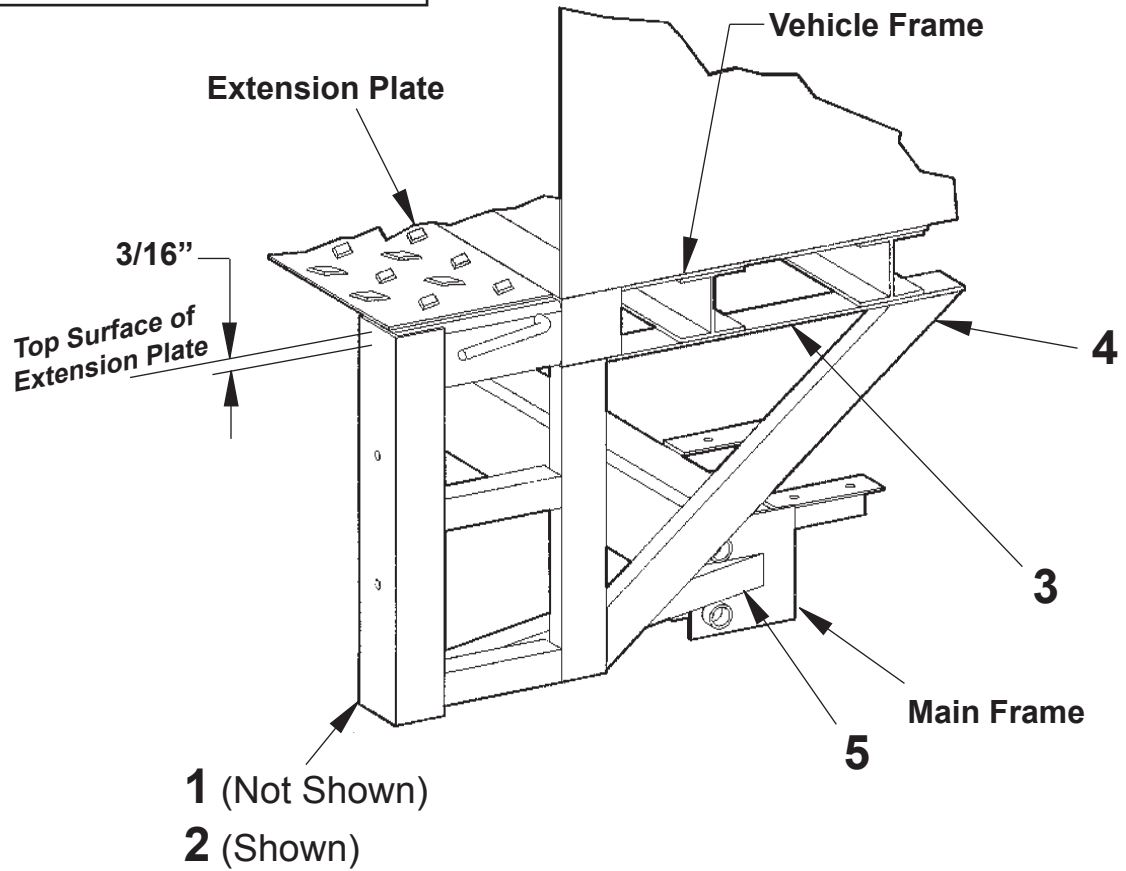

1. Weld Item 1 (P/N 263955-01 LH) & Item 2 (P/N 263955-02 RH) to each corner of extension plate.
2. Weld Item 3 (P/N 263324) to underside of body cross members.
3. Weld Item 4 (P/N 252701-01 & 02) to Item 3 and either Item 1 or 2. Cut as required.

NOTE: Item 5 is not used with 72-150, TE-20, TE-25 & TE-25L model Liftgates.

4. Weld Item 5 (P/N 264006-01 & 02) to main frame & either Item 1 or 2.