

INSTRUCTION, LIFTGATE MOUNTING KIT FOR FRAMELESS TRAILERS WITH SLIDER AXLES (GPT)

NOTE: Kits can only be installed on slider axle trailers with 48.13" distance between inboard surfaces of slider rails.

KIT FOR DRY GOODS TRAILER P/N 282665-01

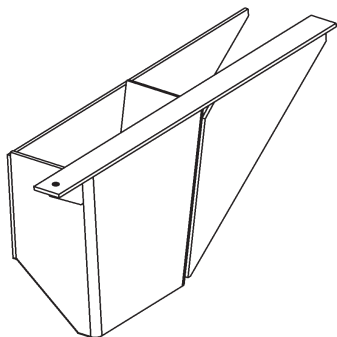

LH MOUNT BRACKET, GPT
P/N 282666-01
QTY. 1

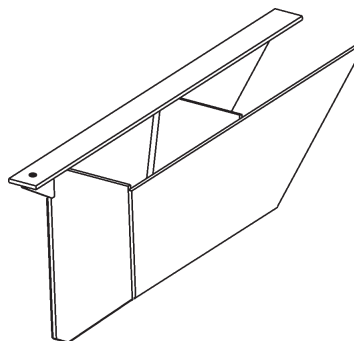

RH MOUNT BRACKET, GPT
P/N 282666-02
QTY. 1

GALVANIZED KIT FOR DRY GOODS TRAILER P/N 282665-01G

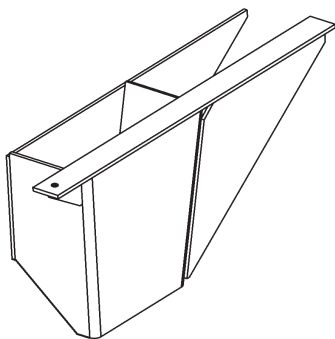

**LH MOUNT BRACKET,
GALVANIZED (GPT)**
P/N 282666-01G
QTY. 1

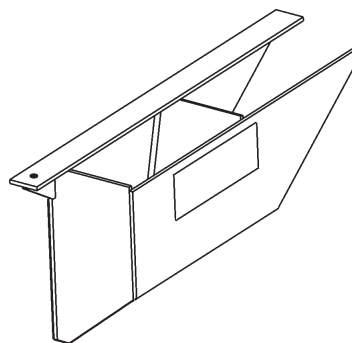

**RH MOUNT BRACKET,
GALVANIZED (GPT)**
P/N 282666-02G
QTY. 1

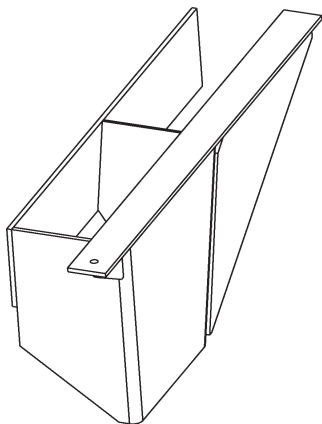
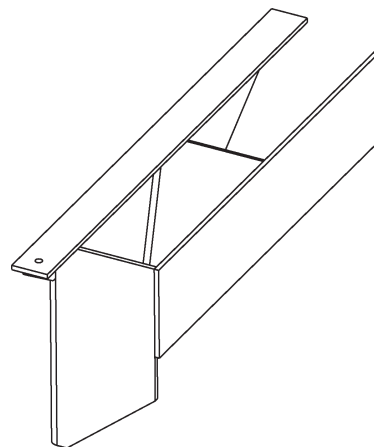
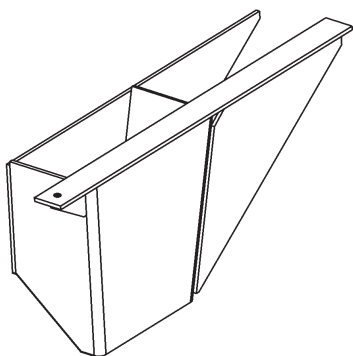
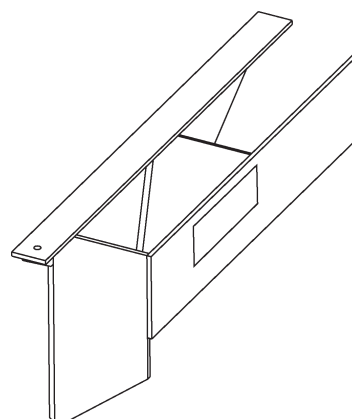
KIT FOR REFRIGERATED TRAILERS**P/N 282970-01****LH MOUNT BRACKET, GPT****P/N 282960-01****QTY. 1****RH MOUNT BRACKET, GPT****P/N 282960-02****QTY. 1****GALVANIZED KIT FOR REFRIGERATED TRAILERS****P/N 282970-01G****LH MOUNT BRACKET,
GALVANIZED (GPT)****P/N 282960-01G****QTY. 1****RH MOUNT BRACKET,
GALVANIZED (GPT)****P/N 282960-02G****QTY. 1**

NOTE: Ensure correct mounting kits are used for dry goods trailers and refrigerated trailers. Refer to kits on sheets 1 and 2.

1. Cut out trailer chassis according to dimensions shown in **FIG. 3-1**.

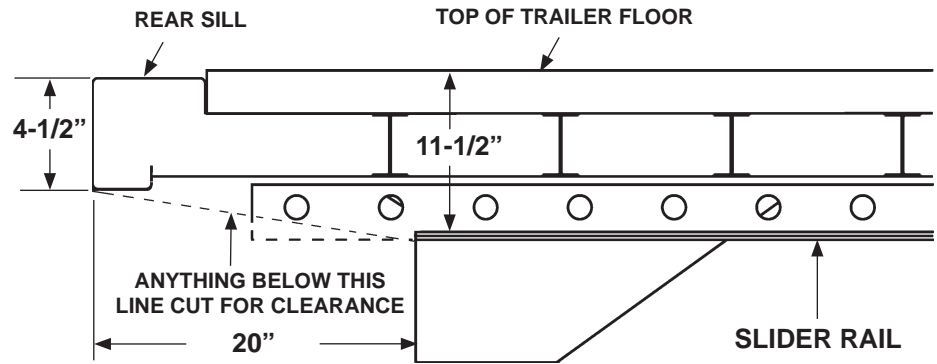

**MINIMUM
CHASSIS CUT FOR STANDARD TRAILER
FIG. 3-1**

⚠ WARNING

Welding on galvanized parts gives off especially hazardous fumes. To minimize hazard remove galvanizing from weld area, provide adequate ventilation, and wear suitable respirator.

CAUTION

Welding across width of trailer cross members weakens trailer chassis. Weld only as shown.

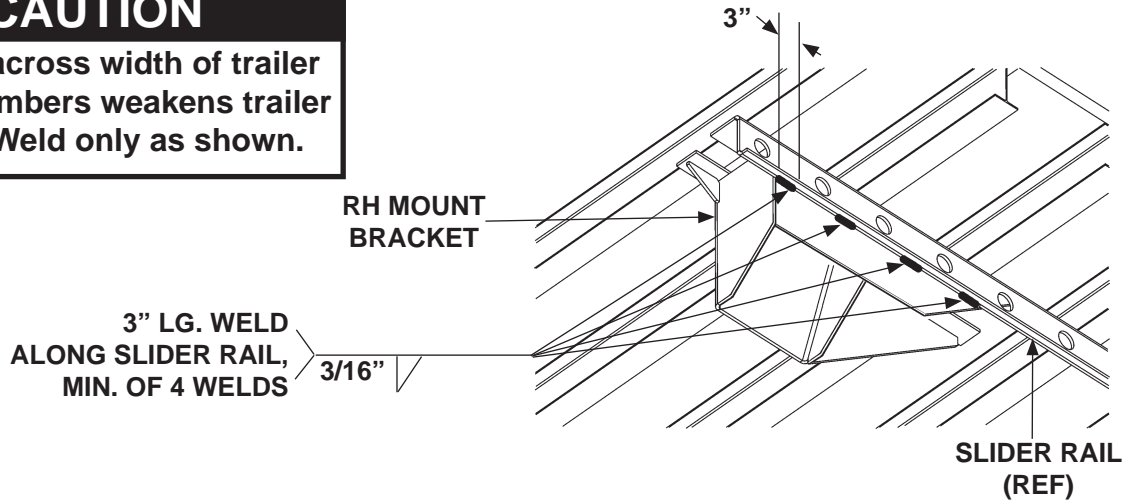

2. Weld the right mount bracket to slider rail on the Right Hand (RH) side of trailer chassis as shown in **FIGS. 4-1, 4-2, and 4-3**. Repeat for left mount bracket.

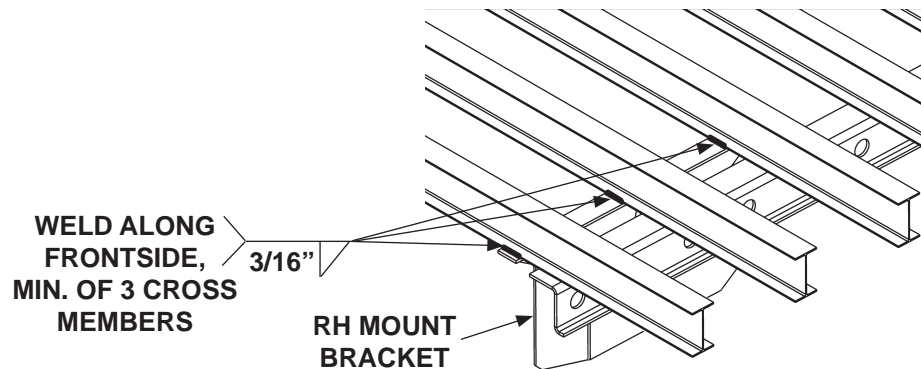
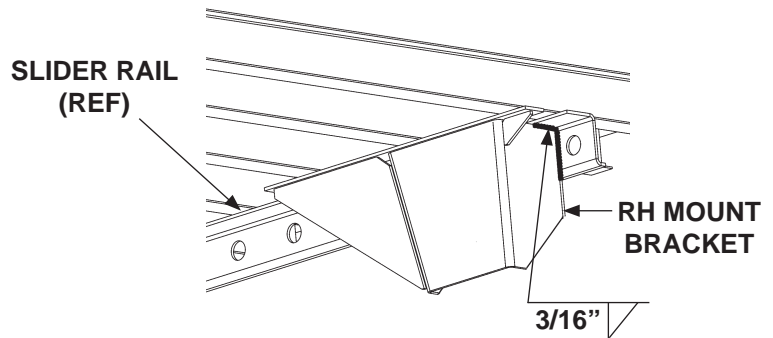

3. If slider rail is not welded to each of the crossmembers as shown, weld the RH trailer slider rail to each crossmember above mount bracket as shown in **FIG. 5-1**. Repeat for LH slider rail.

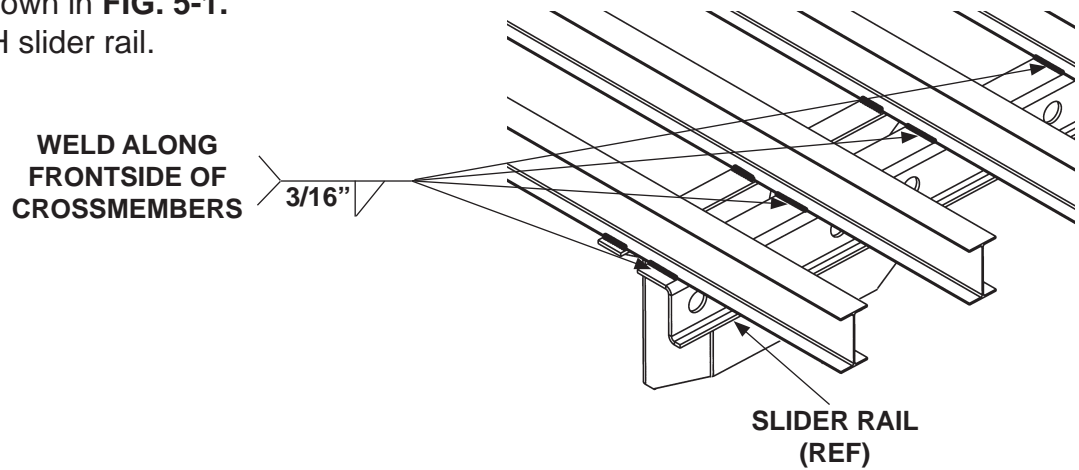

**WELDING SLIDER RAIL TO
TRAILER CROSSMEMBERS
FIG. 5-1**

NOTE: Steps 4-6 are general instructions for positioning mounting plates and welding Liftgate on a slider axle trailer. Galvanized mounting plates are fully welded to main frame at the factory. They cannot be repositioned. For correct installation, use the complete instructions from the Installation Manual supplied with your Liftgate. To get a replacement manual, go to www.maxonlift.com or call Customer Service at (800) 227-4116.

4. Adjust the mounting plates (FIG. 6-1) to proper width of mounting brackets.

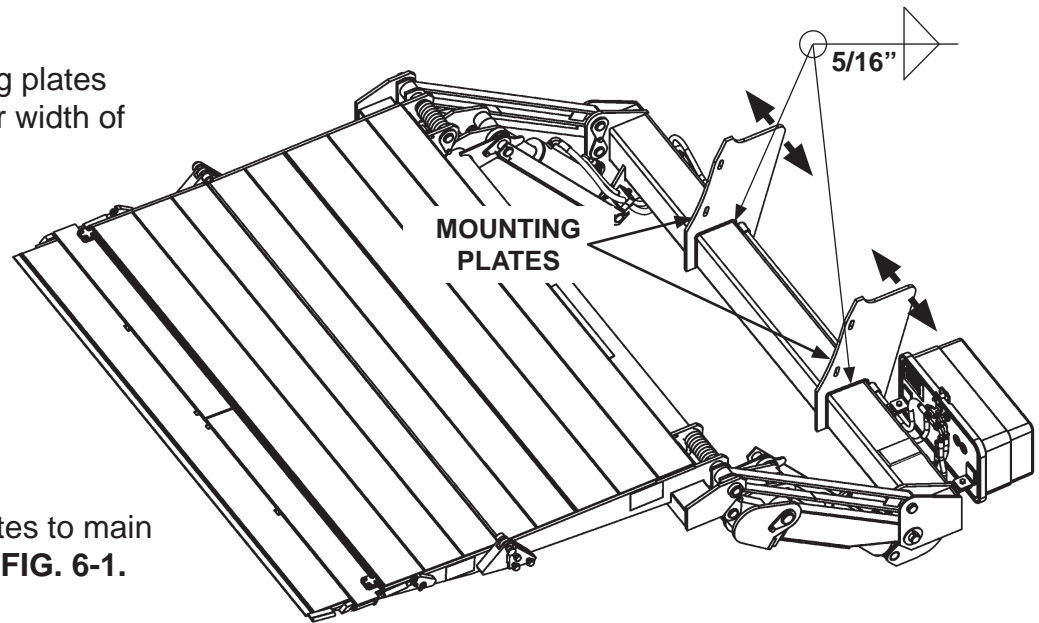

5. Weld mounting plates to main frame as shown in FIG. 6-1.

EXAMPLE OF MOVING PAINTED MOUNTING PLATES ON MAIN FRAME & WELDING IN PLACE

FIG. 6-1

6. Weld Liftgate to RH mount bracket (FIG. 6-2). Repeat for LH mount bracket.

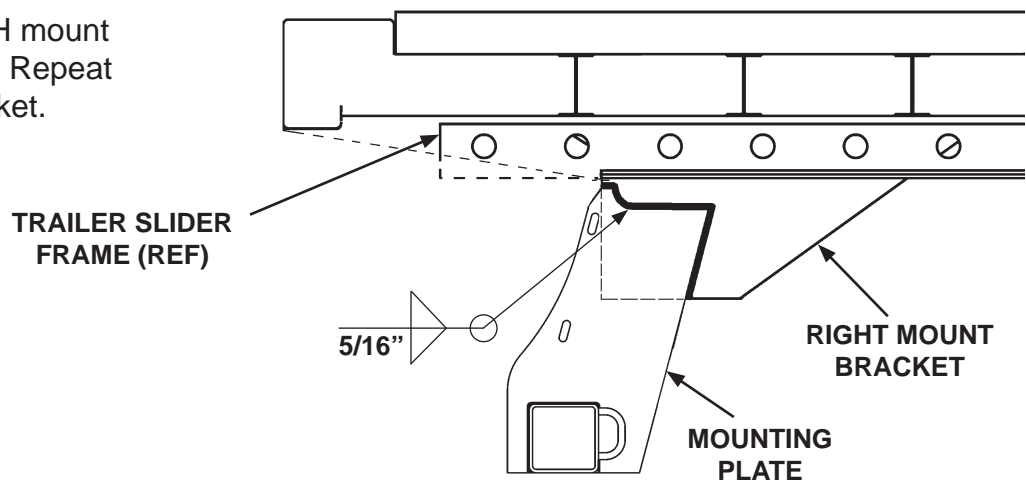

EXAMPLE OF WELDING MOUNTING PLATES TO MOUNT BRACKET ON TRAILER (RH SIDE SHOWN)

FIG. 6-2