

M-99-27
REV. C
OCTOBER 2001

MAINTENANCE MANUAL

TUK-A-WAY[®] LIFTGATE SERIES

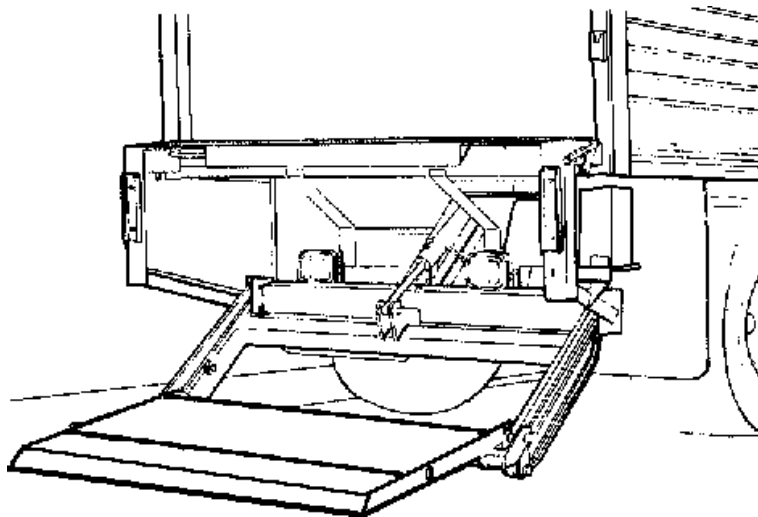

72-25 LMV

72-30 LMV

MAXON[®]
LIFT CORP.

11921 Slauson Avenue.
Santa Fe Springs, CA. 90670
(800) 227-4116

MAXON[®]

LIFT CORP.

**11921 Slauson Ave.
Santa Fe Springs, CA. 90670**

CUSTOMER SERVICE:

TELEPHONE (562) 464-0099 TOLL FREE (800) 227-4116

FAX: (888) 771-7713

**NOTE: Check with Customer Service for updated versions
of Manuals on an annual basis.**

WARRANTY POLICY & PROCEDURE

NEW LIFTGATE WARRANTY

Term of Warranty: 2 Years from Date of In-Service

Type of Warranty: Full Parts and Labor

MAXON agrees to replace any components which are found to be defective during the first 2 years of service, and will reimburse for labor based on MAXON's Liftgate Warranty Flat Rate Labor Schedule. (Call MAXON Customer Service for a copy).

All claims for warranty must be received within 30 Days of the repair date, and include the following information:

1. Liftgate Model Number
2. Liftgate Serial Number
3. Detailed Description of Problem
4. Corrective Action Taken, and Date of Repair.
5. Parts used for Repair, Including MAXON Part Number(s).
6. MAXON R.M.A. # and/or Authorization # if applicable (see below).
7. Person contacted at MAXON if applicable.

All warranty repairs must be performed by an authorized MAXON warranty station. For major repairs, MAXON Customer Service must be notified and an "Authorization Number" obtained. Major repairs would generally be considered repairs made to the structural assembly of the liftgate and/or repairs not outlined in the MAXON Liftgate Warranty Flat Rate Schedule.

Major components (i.e. hydraulic pumps, cylinders, valves, or failed structural parts) must be returned, freight pre-paid, prior to the claim being processed. To ensure timely processing of these warranty claims, an R.M.A. (Returned Merchandise Authorization) number must be obtained from MAXON Customer Service prior to the return of any defective part. Defective Parts must be returned within 60 days of the claim date for consideration to:

**MAXON Lift Corp.
16205 Distribution Way, Cerritos, CA 90703
Attn: RMA# _____**

MAXON's warranty policy does not include the reimbursement for travel time, towing, vehicle rental, service calls, oil, batteries, defects due to misuse or abuse, or loss of income due to downtime. Fabrication of parts, which are available from MAXON, are also not covered.

MAXON's Flat Rate Labor Schedule takes into consideration the time required for diagnosis of a problem.

PURCHASE PART WARRANTY

Term of Warranty: 1 Year from Date of Purchase

Type of Warranty: Part Replacement

MAXON will guarantee all returned genuine replacement parts upon receipt and inspection of parts and invoice.

TABLE OF CONTENTS

LIFTGATE TERMINOLOGY	PAGE 5
WARNINGS	PAGE 6
PERIODIC MAINTENANCE CHECKLIST	PAGE 7
DECALS	PAGE 8
DECALS - LOW VOLTAGE / THERMAL SWITCH (LVTS)	PAGE 9
PLATFORM ADJUSTMENT	PAGE 10
REPLACING PLATFORM TORSION SPRING	PAGE 11
SAFETY HOOK	PAGE 13
PARTS BREAKDOWN.....	PAGE 14
HINGE PINS & BEARINGS LOCATION	PAGE 15
72-25/30LMV ASSEMBLY	PAGE 16
HYDRAULIC ASSEMBLY	PAGE 19
PUMP ASSEMBLY, GRAVITY DOWN	PAGE 20
CONTROL SWITCH, GRAVITY DOWN	PAGE 22
HARNESS & SWITCH ASSEMBLY	PAGE 23
WIRE CONNECTIONS, GRAVITY DOWN	PAGE 24
LOW VOLTAGE / THERMAL SWITCH (LVTS)	PAGE 25
ALUMINUM RETENTION RAMP	PAGE 26
LIQUID SEALANT APPLICATION	PAGE 28
TROUBLESHOOTING	PAGE 29
PLATFORM WILL NOT RAISE	PAGE 30
PLATFORM RAISES BUT LEAKS DOWN	PAGE 31
PLATFORM RAISES PARTIALLY AND STOPS	PAGE 32
LIFTGATE WILL NOT LIFT RATED CAPACITY	PAGE 33
PLATFORM RAISES SLOWLY	PAGE 34
PLATFORM WILL NOT LOWER	PAGE 35

LIFTGATE TERMINOLOGY

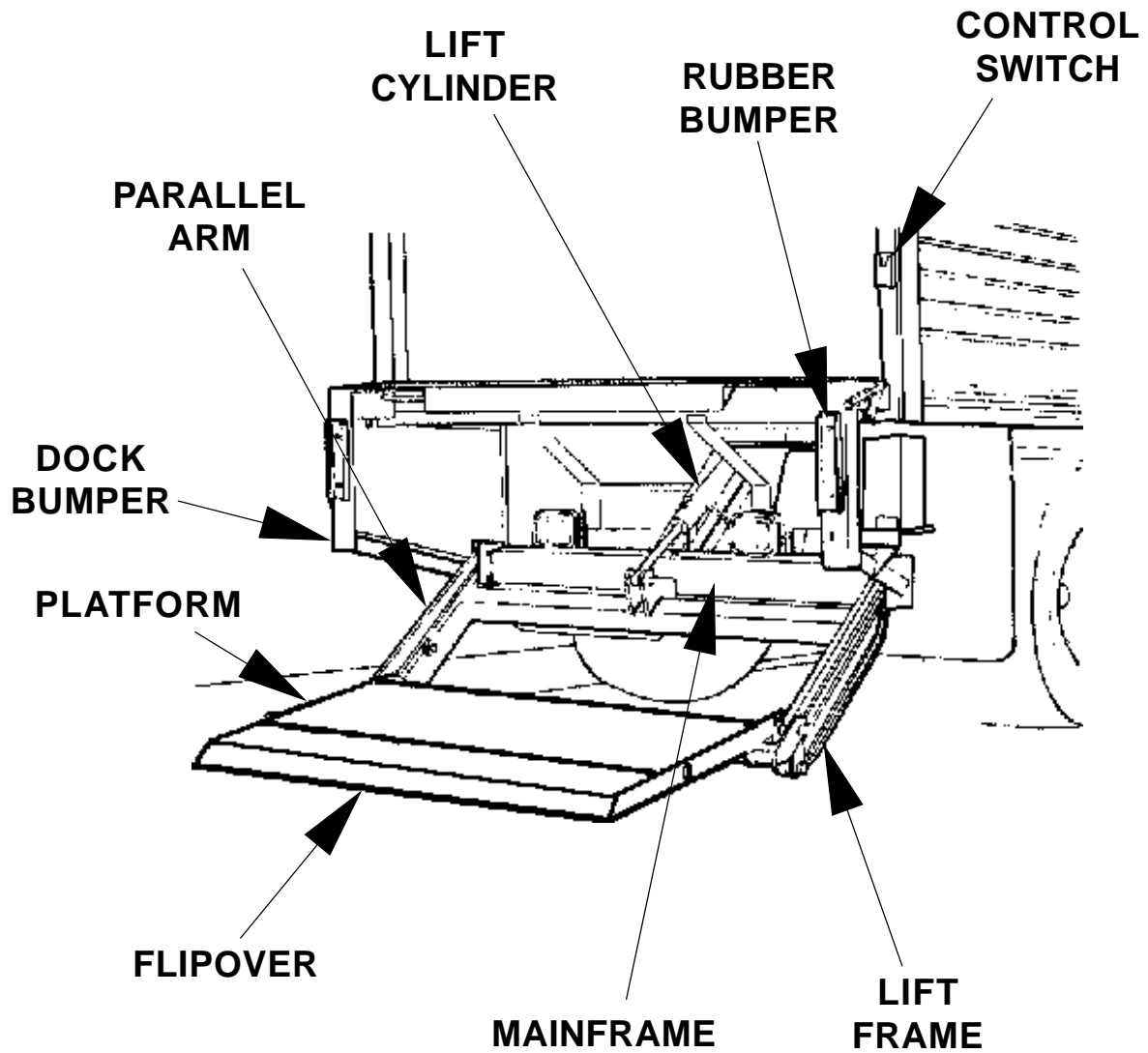

Comply with the following **WARNINGS** while maintaining Liftgates. See Operation Manual M-99-26 for operating safety requirements.

WARNING

- Read and understand the instructions in this **Maintenance Manual** before performing maintenance on the Liftgate.
- Before operating the Liftgate, read and understand the operating instructions in Operation Manual M-99-26.
- Comply with all **WARNING** and instruction decals attached to the Liftgate.
- Keep decals clean and legible. If decals are defaced or missing, replace them. Free replacement decals are available from **Maxon Parts Department**.
- Consider the safety and location of bystanders and location of nearby objects when operating the Liftgate. Stand to one side of the platform while operating the Liftgate
- Do not allow untrained persons to operate the Liftgate.
- Do not stand under, or allow obstructions under the platform when lowering the Liftgate. **Be sure your feet are clear of the Liftgate.**
- **Keep fingers, hands, arms, legs, and feet clear of moving Liftgate parts (and platform edges) when operating the Liftgate.**
- **Correctly stow platform when not in use. Extended platforms could create a hazard for people and vehicles passing by.**
- **Disconnect Liftgate power cable from battery** before repairing or servicing Liftgate.
- Wear appropriate safety equipment such as protective eyeglasses, faceshield and clothing while performing maintenance on the Liftgate and handling the battery. Debris from drilling and contact with battery acid may injure unprotected eyes and skin.
- Be careful working by an automotive type battery. Make sure the work area is well ventilated and there are no flames or sparks near the battery. Never lay objects on the battery that can short the terminals together. If battery acid gets in your eyes, immediately seek first aid. If acid gets on your skin, immediately wash it off with soap and water.
- If an emergency situation arises (vehicle or Liftgate) while operating the Liftgate, release the control Toggle Switch and the Liftgate will stop.
- A correctly installed Liftgate operates smoothly and reasonably quiet. The only noticeable noise during operation comes from the pump unit while the platform is raised. Listen for scraping, grating and binding noises and correct the problem before continuing to operate Liftgate.
- If it is necessary to stand on the platform while maintaining the Liftgate, keep your feet and any objects clear of the inboard edge of the platform. Your feet or objects on the platform could be trapped between the platform and the Liftgate extension plate.
- Never perform unauthorized modifications on the Liftgate. Modifications may result in early failure of the Liftgate and may create hazards for Liftgate operators and maintainers.
- Use only **Maxon Authorized Parts** for replacement parts. Order replacement parts from:

MAXON LIFT CORP. Parts Department
11921 Slauson Ave., Santa Fe Springs, CA 90670
Phone: (800) 227-4116

PERIODIC MAINTENANCE CHECKLIST



WARNING

Never operate the Liftgate with parts loose or missing.

Annually

Visually check the entire Liftgate for excessively worn parts and broken welds, especially the Hinge Pins. See parts breakdown illustrations for replacement parts.

Semi-annually

Visually check the Platform Hinge Pins for excessive wear and broken welds. See parts breakdown illustrations for replacement parts.

Quarterly

Check the hydraulic fluid level in the Pump Reservoir. If hydraulic fluid must be added, select the correct grade of fluid to use at your location.

20-150 Degrees F	- Grade ISO 32
Below 20 Degrees F	- Grade ISO 15

If hydraulic fluid appears contaminated, change hydraulic fluid.

Keep track of the grade of hydraulic fluid in the Pump Reservoir and never mix two different grades of fluid.

Check Hoses and Fittings for chaffing and fluid leaks. Replace if necessary.

Check electrical wiring for chaffing and make sure wiring connections are tight and free of corrosion.

Check that all bolts are tight.

Check that all WARNING decals are in place and legible.

Check that all roll pins are in place and protrude evenly from both sides of Hinge Pin collar. Replace roll pins if necessary.

Check if Safety Hook operates correctly and if it requires lubrication. Refer to Safety Hook topic in this manual for inspection, lubrication and adjustment information.

DECALS

Read and understand decals and applicable WARNINGS at the front of this Manual before operating Liftgate.

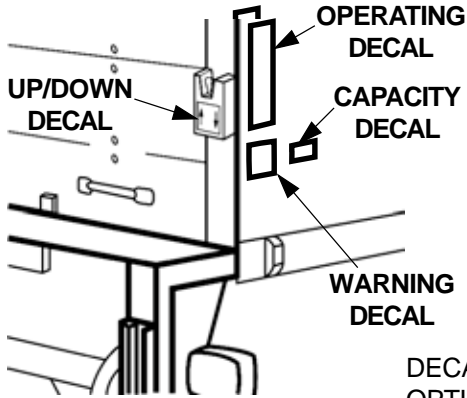

RECOMMENDED DECAL LOCATIONS

DECAL FOR CAB CUT-OFF OPTION, ONLY (LOCATED INSIDE CAB)

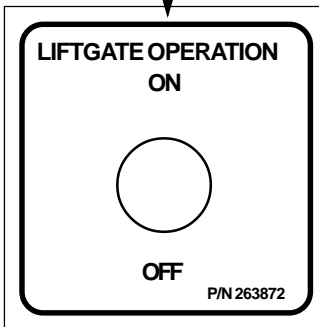
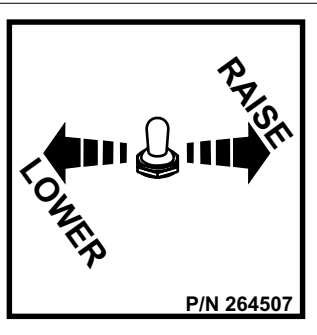

WARNING READ CAREFULLY

- Improper operation of this Lift can result in serious personal injury. Do not operate unless you have been properly instructed and have read, and are familiar with the operating instructions. If you do not have a copy of the instructions, please obtain them from your employer, distributor, or lessor, before you attempt to operate Lift.
- Be certain that the vehicle is properly and securely braked before using the Lift.
- Always inspect this Lift for maintenance or damage before using it. If there are signs of improper maintenance, damage to vital parts, or slippery Platform surface, do not use the Lift until these problems have been corrected.
- Do not overload the Lift. The load limit is based on evenly distributed cargo over the entire Platform surface. If you are using a pallet jack, be sure it can be maneuvered safely. Do not operate a forklift on the Platform or travel with the platform in an open position at any time.
- Load should be placed in a stable position close to the edge of the Platform nearest the truck. The heaviest portion of the load should never be placed beyond the center of the Platform away from the truck.
- Never allow yourself, a helper, or bystander to stand in a position where a falling load could land on either of you. Also do not allow any part of yours or your helper's body to be placed under, within, or around any portion of the moving liftgate, or its mechanisms, or in a position that would trap them between the platform and the ground or truck when the liftgate is operated.
- If a helper is riding the Platform with you, make sure you are both doing so safely and that you are not in danger of coming in contact with any moving or potentially moving obstacles. USE GOOD COMMON SENSE. If load appears to be unsafe, do not lift or lower it.

MAXON LIFT CORP.

PART NO. 264081

Operating Instructions TUK-A-WAY® Units

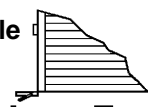
Depress handle & activate Toggle Switch to lower stowed liftgate.  This point must touch ground. **1**

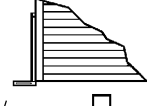
Open Platform  **2**

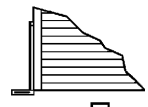
Open Flipover  **3**

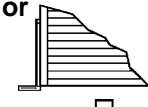
Activate toggle switch to Raise or Lower platform  **4**

To Tuck unit away, reverse steps 1,2,& 3. **5**

MAXON
LIFT CORP. P/N 251867

THE MAXIMUM CAPACITY OF THIS LIFT IS 2500 LBS. WHEN THE LOAD IS CENTERED ON THE LOAD CARRYING PLATFORM

P/N 220382

THE MAXIMUM CAPACITY OF THIS LIFT IS 3000 LBS. WHEN THE LOAD IS CENTERED ON THE LOAD CARRYING PLATFORM

P/N 220388

DECALS - LOW VOLTAGE / THERMAL SWITCH (LVTS) (IF EQUIPPED ON LIFTGATE)

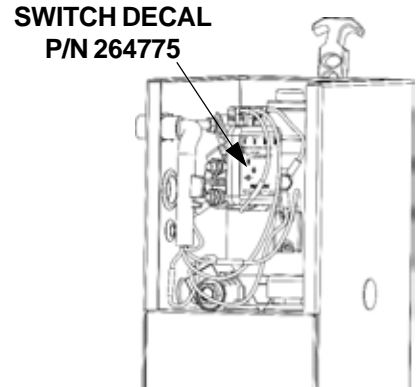
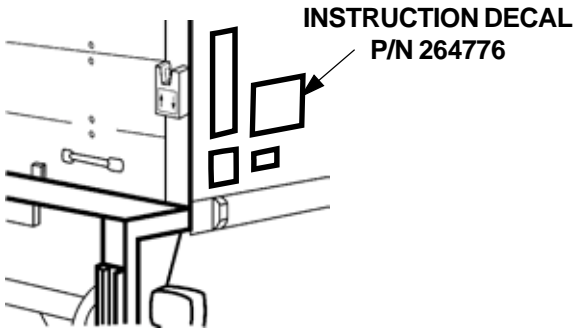

RECOMMENDED DECAL LOCATIONS

Read and understand decals on Liftgate and the applicable WARNINGS at the front of this Manual before operating Liftgate.

INSTRUCTION DECAL
P/N 264776

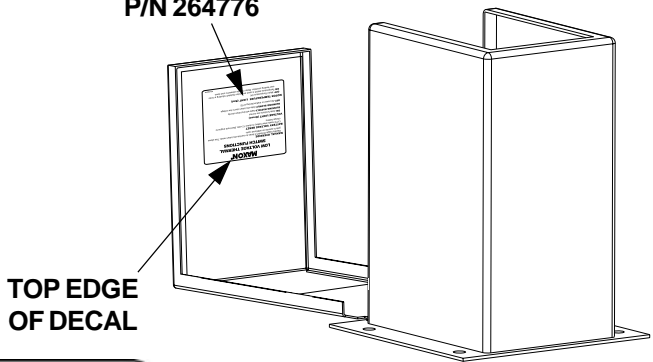

MAXON®

LOW VOLTAGE / THERMAL SWITCH (LVTS) INSTRUCTIONS

The LVTS system protection device, located inside the pump box on this liftgate, is designed to shutdown its operation when the motor temperature is too high or the battery voltage too low for reliable operation. Please follow the instructions below in the event this occurs.

VOLTAGE LIGHT (Green)

ON- Gate functions are normal

BLINKING RAPIDLY- Gate will shut down shortly

BLINKING SLOWLY- Gate shut down

OFF- No power or malfunctioning LVTS

MANUAL OVERRIDE
Rapidly toggle lift switch to the up position and back to the center position 5 times to override shut down mode. This allows gate to operate an additional cycle.

BATTERY VOLTAGE RESET
LVTS resets when battery is above 13 volts. Start truck engine to charge battery.

MOTOR TEMPERATURE LIGHT (Red)

OFF- Motor Temperature OK

ON- Motor is overheated and has shut down. Temperature switch will reset automatically and red light will go out when the motor has cooled down.

Red

Green

P/N 264776

TD IN	SW IN	BAT	GND
○ MOTOR TEMPERATURE (Red)			
○ VOLTAGE (Green)			
Refer to LVTS Instructions Decal or Operation Manual			
■ SOL			
■ MOTOR			
MAXON®			
LOW VOLTAGE THERMAL SWITCH LVTS			
S/N XXXXXXXX		P/N 264775	

PLATFORM ADJUSTMENT

1. Open and **RAISE** Platform to bed level as shown in **Operation Manual M-99-26**. Platform should be pointing up at bed level and pointing down at ground level (**FIG. 1A** and **FIG. 1B**).

2. If the platform is level at bed height (**FIG.1C**) and sags at ground level (**FIG.1D**), inspect each of the Hinge Pins for visible wear before adjusting the Platform. Refer to Hinge Pin Location illustration in the Parts Breakdown section of this manual. Replace Hinge Pins that are visibly worn.

3. Check Liftgate for structural damage that may cause incorrect platform positioning. Repair structural damage.

4. If the platform is level at bed height (**FIG.1C**) and sags at ground level (**FIG.1D**), weld 1-1/2" x 3-1/2" shims in 1/16" increments to each lift arm Shackle (roadside and curbside) as shown in **FIG. 2**. Make sure bottom edge of shim is flush with bottom edge of shackle. Each shim raises up the outboard edge of the flipover as shown in **TABLE 1**.

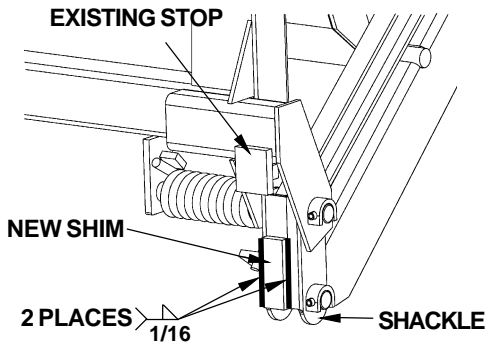

FIG. 2

NO. OF SHIMS (1/16") ADDED	RAISES FLIPOVER EDGE (OUTBOARD)
1	7/8"
2	1-3/4"
3	2-5/8"
4	3-1/2"

TABLE 1

5. If the outboard edge of the flipover will not reach level ground, grind off metal in 1/16" increments from the existing stop on the Platform (roadside and curbside) as shown in **FIG. 3**. Each 1/16" ground off the existing stop lowers the outboard edge of the flipover as shown in **TABLE 2**.

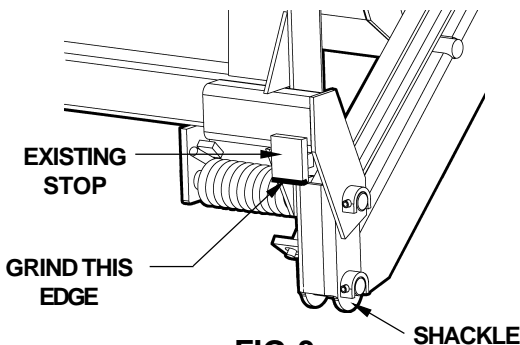
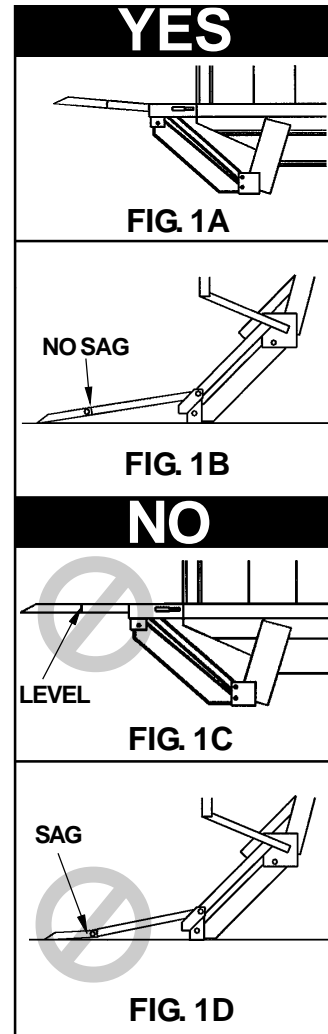

FIG. 3

GRIND OFF EXISTING SHIM	LOWERS FLIPOVER EDGE (OUTBOARD)
1/16"	7/8"
1/8"	1-3/4"
3/16"	2-5/8"
1/4"	3-1/2"

TABLE 2



REPLACING PLATFORM TORSION SPRING

1. Manually fold Flipover onto Platform as shown in **Operation Manual M-99-26**.
2. Raise Liftgate to a convenient work height to gain access and release tension on the Torsion Spring.

CAUTION
Make sure there is no tension on spring.

3. Drive out the roll pin from pin collar on the Platform Hinge Bracket. Drive the platform Hinge Pin out of the Shackle with a hammer and pin punch, just enough to free the torsion spring (**FIG. 4**). Remove spring from Shackle.
4. Install the Torsion Spring as shown in (**FIG. 5**). Make sure the long leg of the spring is inserted in the bracket located on the Shackle. Make sure the short end of the spring is visible and resting against the block on the Platform Hinge Bracket (**FIG. 5**).

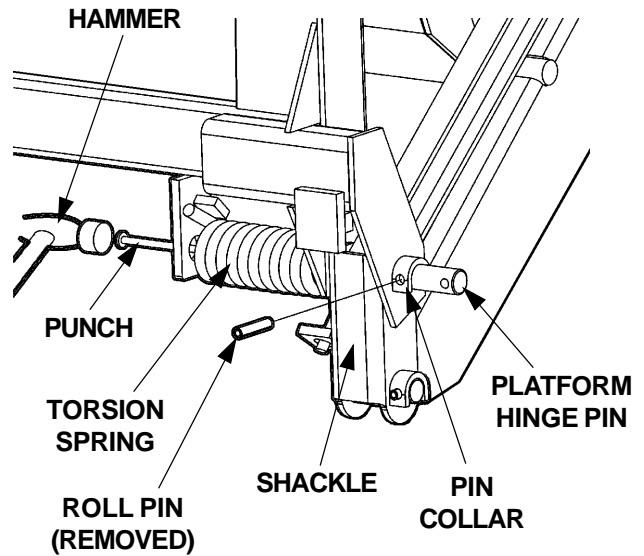

FIG. 4

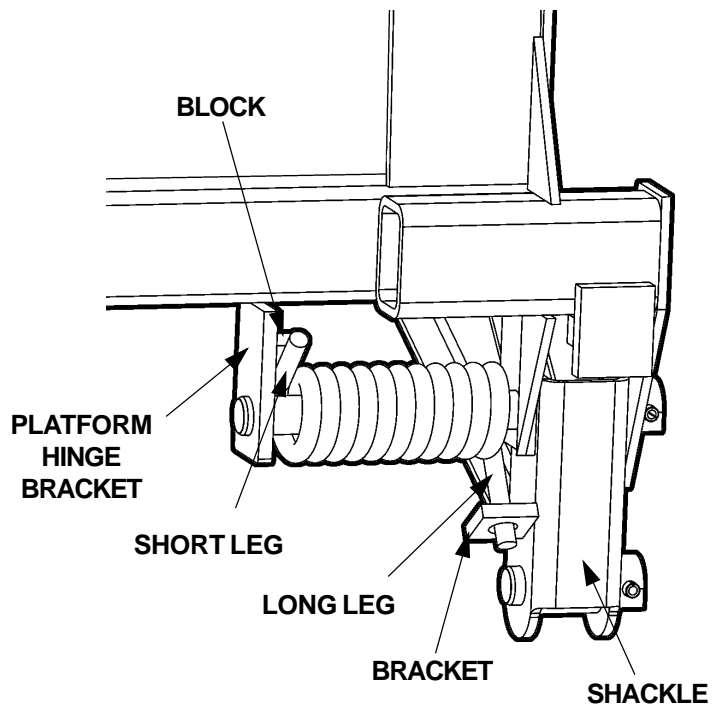

FIG. 5

REPLACING PLATFORM TORSION SPRING - Continued

5. Drive Platform Hinge Pin into correct position through the Platform Hinge Bracket with a hammer and pin punch as shown in **(FIG. 6)**. Line up the hole in the Platform Hinge Pin with the hole in the Pin Collar. Install the roll pin through the Pin Collar until roll pin protrudes equally from both sides of the collar **(FIG. 6)**.
6. Operate the Liftgate according to instructions in **Operation Manual M-99-26** to make sure it operates correctly.

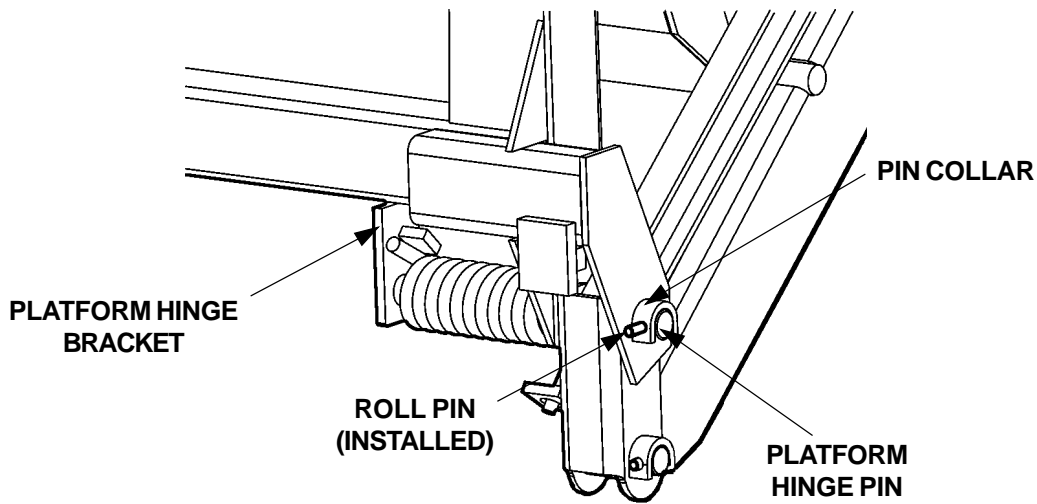

FIG. 6

MAXON[®]

11921 Slauson Ave. Santa Fe Springs, CA. 90670 (800) 227-4116 FAX (888) 771-7713

SAFETY HOOK

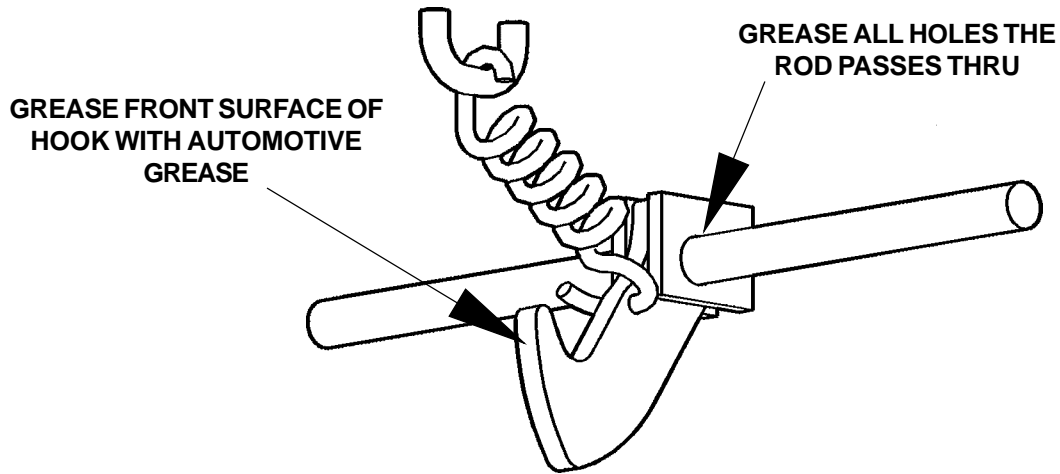

FIG. 7

CHECK SAFETY HOOK FUNCTION

1. When the Platform is raised to full "Stowed" position, listen for an audible snap when **Safety Hook** engages the **Platform Loop**.
2. Visually check if loop is fully engaged with the Safety Hook as shown in **FIG. 8**.

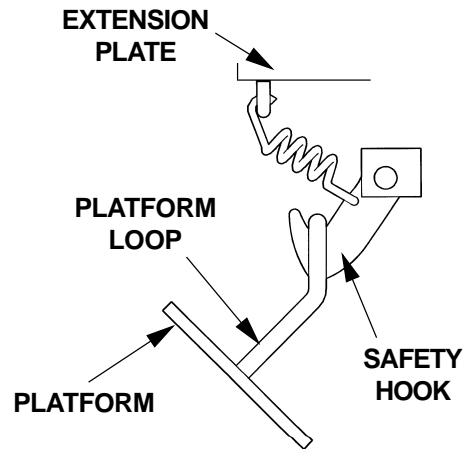

FIG. 8

LOOP ADJUSTMENT

1. If the Safety Hook is not seating correctly as shown in **FIG. 9**, **LOWER** Platform to ground level (**Operation Manual M-99-26**).
2. Adjust by bending the Platform Loop as shown in **FIG. 9**.
3. **RAISE** Platform and check for correct Safety Hook engagement. Repeat adjustment if required.

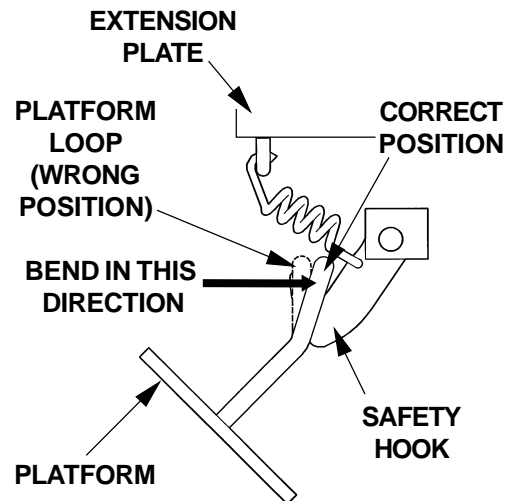

FIG. 9

MAXON[®]

11921 Slauson Ave. Santa Fe Springs, CA. 90670 (800) 227-4116 FAX (888) 771-7713

PARTS BREAKDOWN

HINGE PINS & BEARINGS LOCATION

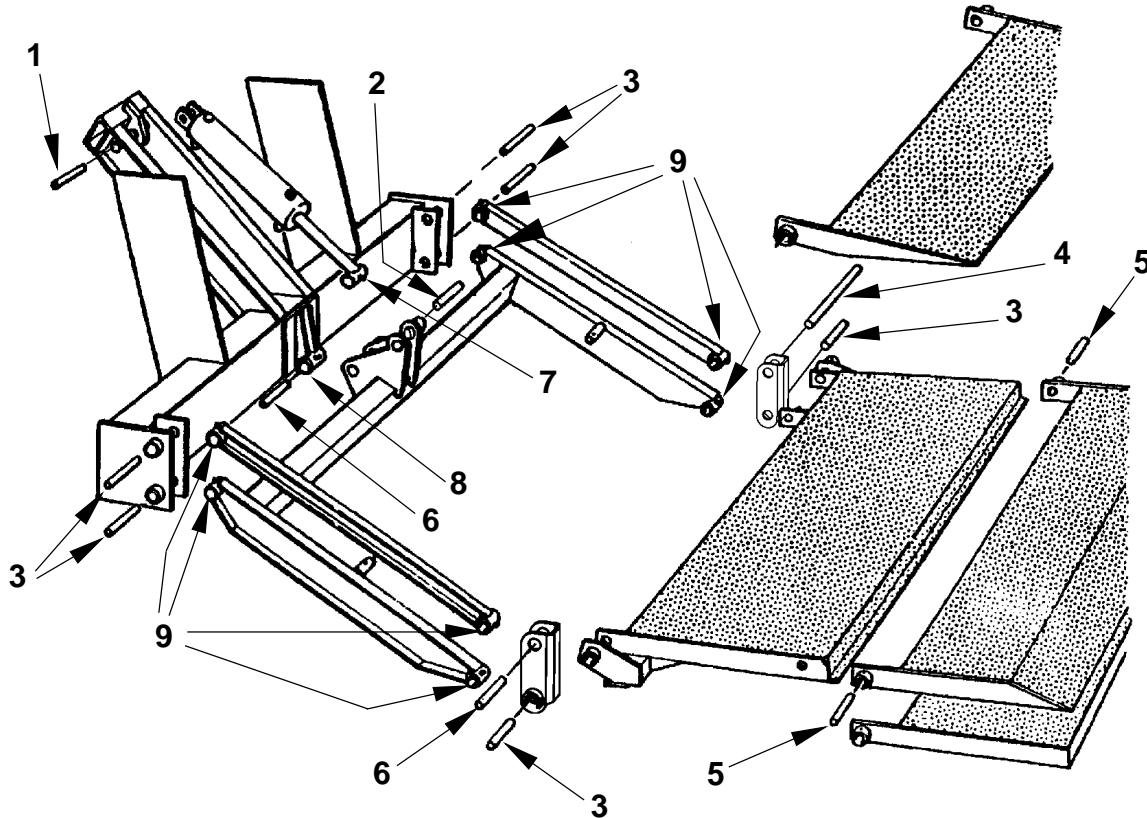

PINS				BEARINGS			
ITEM	QTY.	PART NO.	DESCRIPTION	ITEM	QTY.	PART NO.	DESCRIPTION
1	1	203405-09	PIN x 4"	8	1	260369	BEARING SELF LUBE 1-1/8 x 2"
2	1	260368-05	PIN x 5"	9	8	260363	BEARING SELF LUBE 1 x 1-1/2"
3	6	260368-03	PIN x 3-1/2"				
4	1	260368-02	PIN x 11"				
5	2	203405-05	PIN x 3-1/4"				
6	2	260368-04	PIN x 4-1/2"				
7	1	260373	BEARING SELF LUBE 1 x 2"				

72-25/30LMV ASSEMBLY

MAXON[®]

11921 Slauson Ave. Santa Fe Springs, CA. 90670 (800) 227-4116 FAX (888) 771-7713

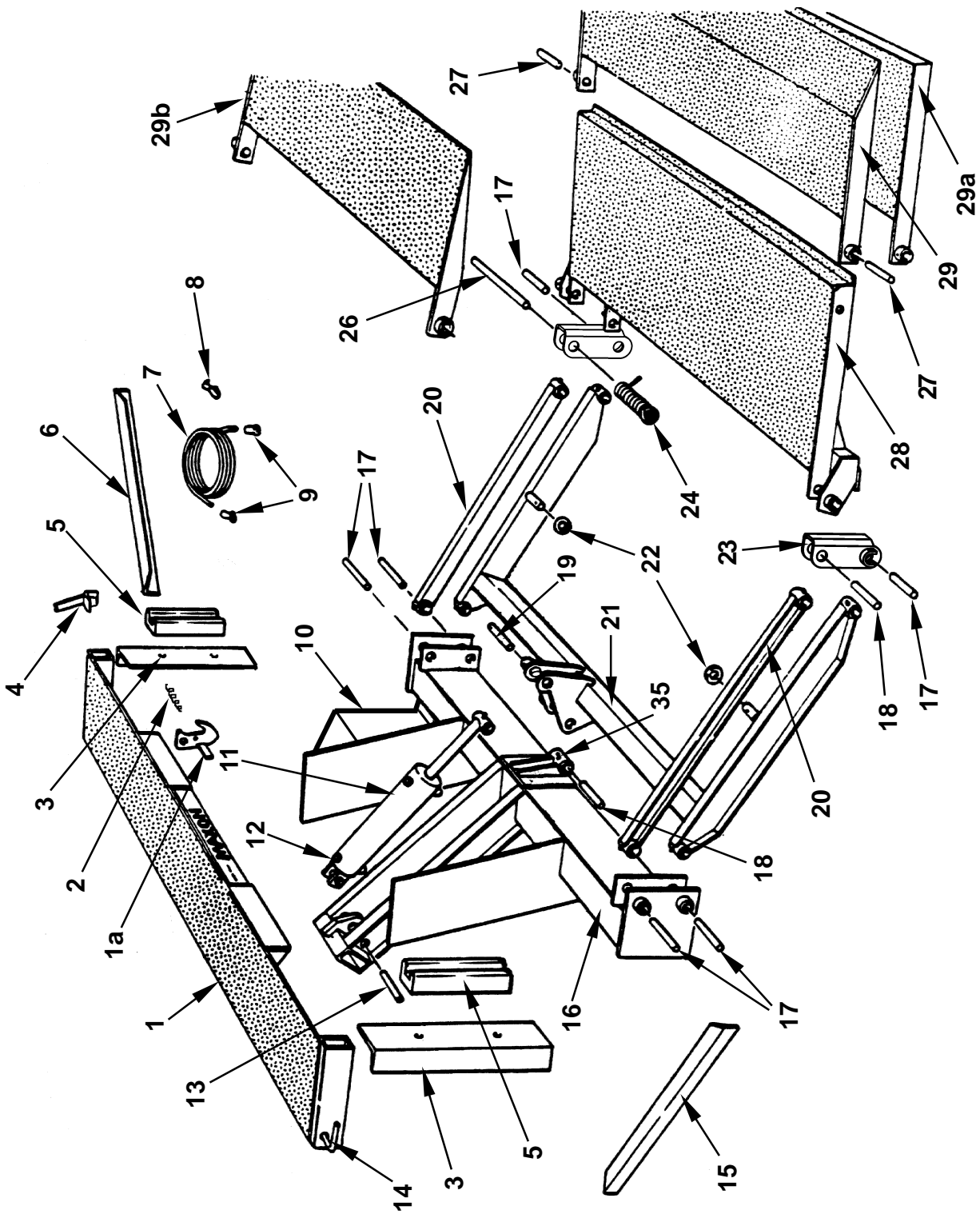

72-25/30LMV ASSEMBLY - Continued

ITEM	QTY.	PART NUMBER	DESCRIPTION
1	1	207914-100	EXTENSION PLATE WELDMENT
1a	1	215341	SAFETY HOOK WELDMENT
2	1	215345	SPRING SAFETY HOOK
3	2	201638	DOCK BUMPER
4	1	203412	RENTAL LOCK DEVICE
5	2	222988	RUBBER BUMPER
6	1	201637-02	ANGLE, DOCK BUMPER SUP. R.H.
7	1	264422	POWER CABLE ASS'Y, 200 AMPS
8	7	050079	CABLE FRAME CLIP #2
9	1	226778	CABLE END #2
10	1	263613	PUMP ASSY.
11	1	260372	CYLINDER, 3" x 10" (72-25)
		260392	CYLINDER, 3-1/2" x 10" (72-30)
11a	1	260372-SK	SEAL KIT (72-25)
		260392-SK	SEAL KIT (72-30)
12	1	201695	BREATHER, CYLINDER
13	1	203405-09	PIN x 4"
14	1	203411	STREET SIDE CNTL ROD ASSEMBLY
15	1	201637-01	ANGLE, DOCK BUMPER SUPPORT
16	1	260436	MAIN FRAME ASSEMBLY
17	6	260368-03	PIN, x 3-1/2"
18	2	260368-04	PIN, x 4-1/2"
19	1	260368-05	PIN, x 5"

72-25/30LMV ASSEMBLY - Continued

ITEM	QTY.	PART NUMBER	DESCRIPTION
20	2	260370	PARALLEL ARM ASSEMBLY
21	1	260315	LIFT FRAME ASSEMBLY
22	2	221867	ROLLER x 3/4"
23	1	280347-01	SHACKLE WELDMENT LH
24	1	201640	TORSION SPRING
25	1	280347-02	SHACKLE WELDMENT RH
26	1	260368-02	PIN, x 11"
27	2	203405-05	PIN, x 3-1/4"
28	1	280369	PLATFORM ASSEMBLY
29	1	201629	FLIPOVER ASSY. RAMP TYPE (STD.)
OPTIONAL 29a		201680	FLIPOVER ASSY. BUTT END TYPE
29b		213085	FLIPOVER ASSY. WEDGE TYPE
29c		253874-01	FLIPOVER ASSY. w/10" A.R.R. (Not Shown)
30	1	M-99-25	INSTALLATION MANUAL (Not Shown)
31	1	M-99-26	OPERATION MANUAL (Not Shown)
32	1	M-99-27	MAINTENANCE MANUAL (Not Shown)
33	1	251867	DECAL, OPERATING (Not Shown)
34	1	260008	DECAL, WARNING (Not Shown)
35	1	260369	BEARING SELF-LUBRICATING 1-1/8 x 2" LG.

MAXON®

11921 Slauson Ave. Santa Fe Springs, CA. 90670 (800) 227-4116 FAX (888) 771-7713

HYDRAULIC ASSEMBLY

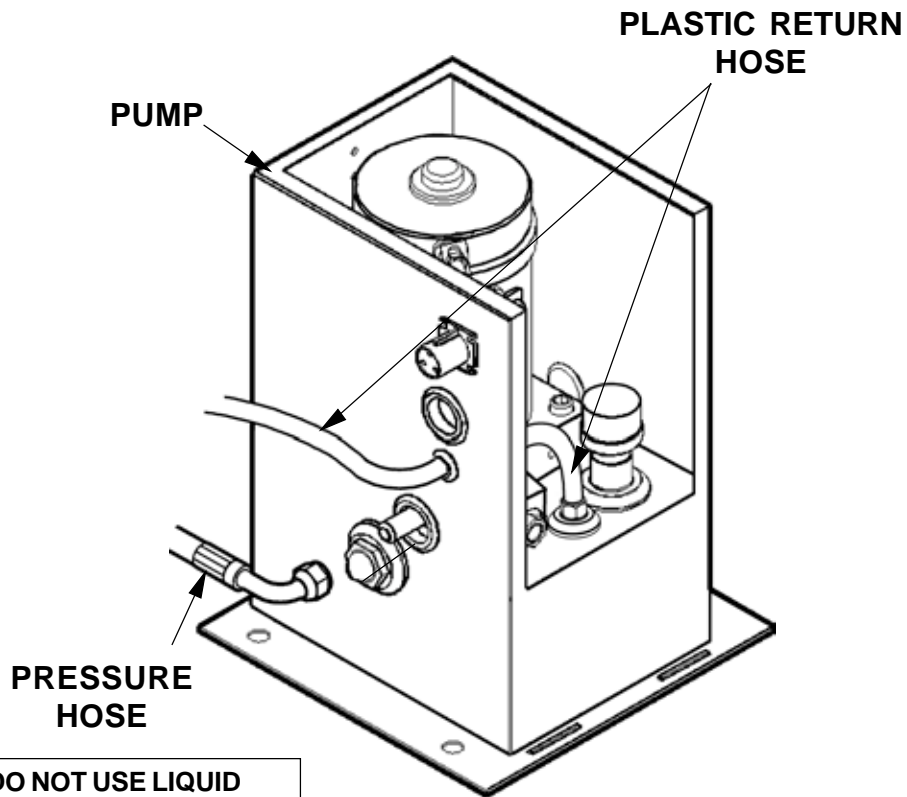

NOTE: DO NOT USE LIQUID SEALANT ON HOSE AND PUMP BOX FITTINGS SHOWN ABOVE.

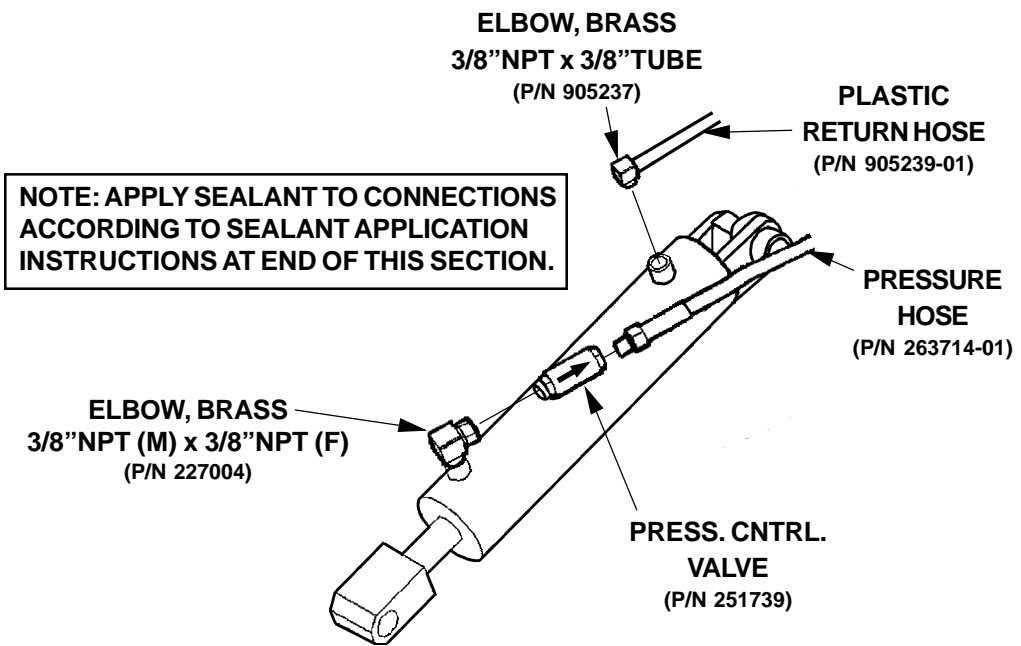

NOTE: APPLY SEALANT TO CONNECTIONS ACCORDING TO SEALANT APPLICATION INSTRUCTIONS AT END OF THIS SECTION.

MAXON[®] 11921 Slauson Ave. Santa Fe Springs, CA. 90670 (800) 227-4116 FAX (888) 771-7713

PUMP ASSEMBLY, GRAVITY DOWN

P/N 263613

MAXON[®]

11921 Slauson Ave. Santa Fe Springs, CA. 90670 (800) 227-4116 FAX (888) 771-7713

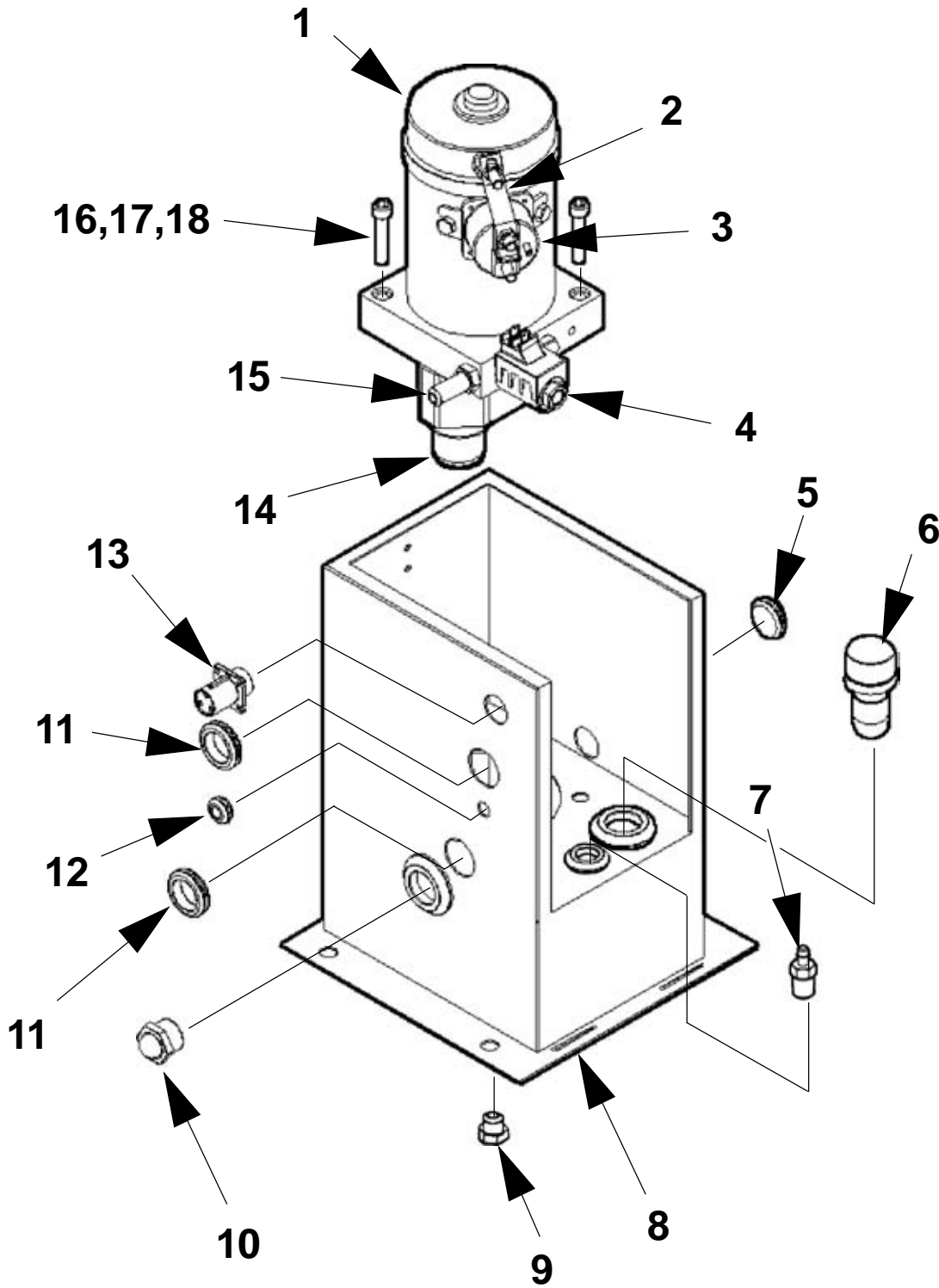

PUMP ASSEMBLY, GRAVITY DOWN - Continued



ITEM	QTY.	PART NO.	DESCRIPTION
1	1	263612	SLIMLINE PUMP ASSEMBLY 12 VDC
2	1	262966	BUS BAR
3	1	262939	MOTOR SOLENOID
4	1	253353	VALVE, SOLENOID, 2-WAY
4a	1	226594	O-RING KIT, 2-WAY VALVE
5	1	263779	PLUG
6	1	263369	FILLER
7	1	263811	CONNECTOR, 3/8"
8	1	263500	BOX ASSEMBLY
8a	1	263497	COVER
8b	1	263499	BOX WELDMENT
8c	1	263791	LATCH
9	1	030937	HEX PLUG, 1/4"
10	1	263370	FLOW SIGHT
11	2	263814	GROMMET, 1" DIA.
12	1	263795	GROMMET, 1/2" DIA.
13	1	263798	PUMP BOX HARNESS
13a	1	263802	GASKET
14	1	260250	FILTER
15	1	905100	BULKHEAD, MALE, JIC #6
16	2	030039	BOLT, 3/8-16 x 1-3/4" LG.
17	2	030555	WASHER, LOCK, 3/8"
18	2	030556	WASHER, FLAT, 3/8"

CONTROL SWITCH, GRAVITY DOWN

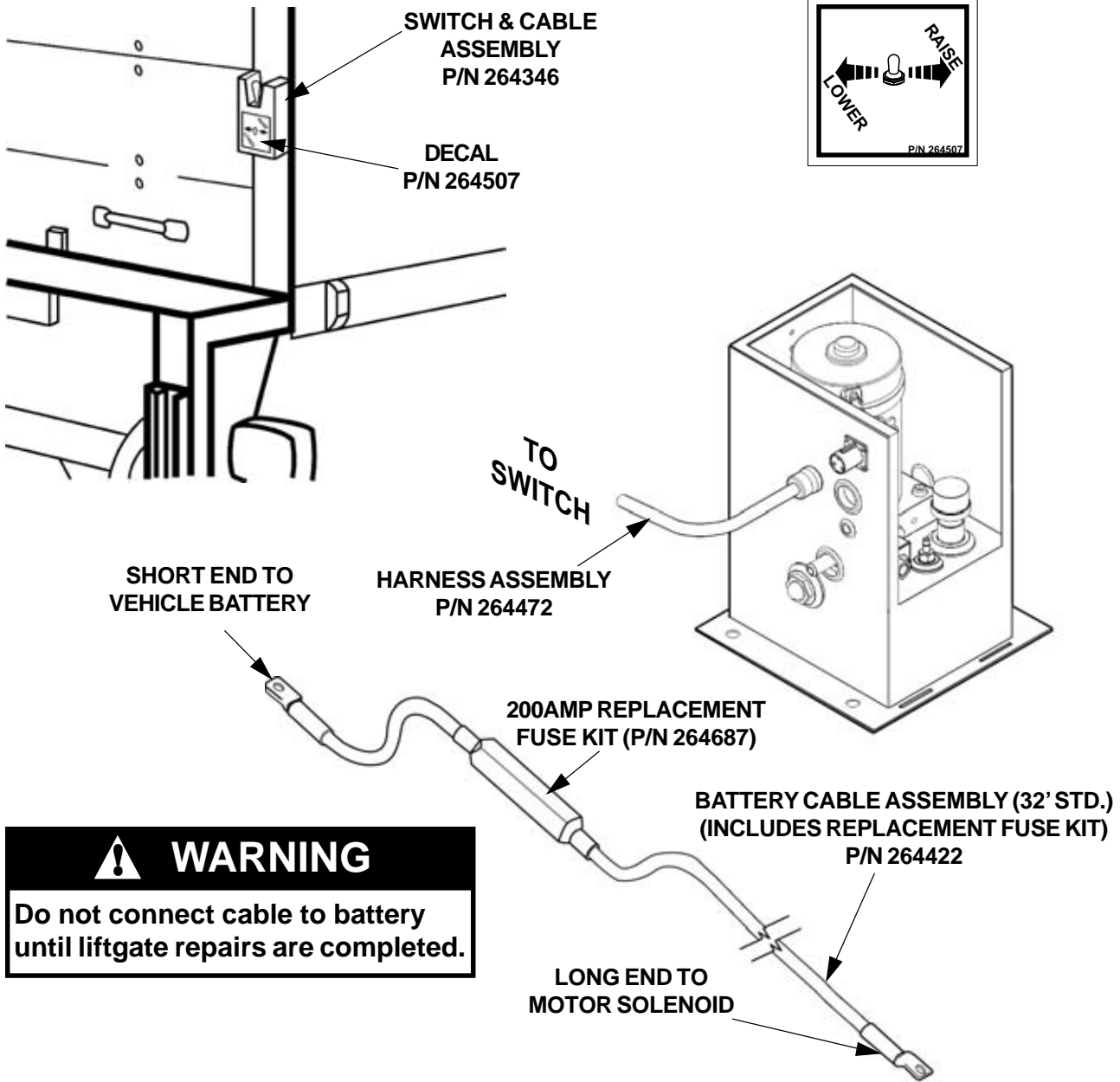
Assemble Switch to the vertical post as shown.



ADDITIONAL AVAILABLE BATTERY CABLE KITS

	PART NUMBER	
40' CABLE ASSEMBLY	264848	CABLE ASSEMBLY 
10' EXTENSION CABLE ASSEMBLY	264849	EXTENSION CABLE ASSEMBLY 

MAXON

11921 Slauson Ave. Santa Fe Springs, CA. 90670 (800) 227-4116 FAX (888) 771-7713

HARNESS & SWITCH ASSEMBLY

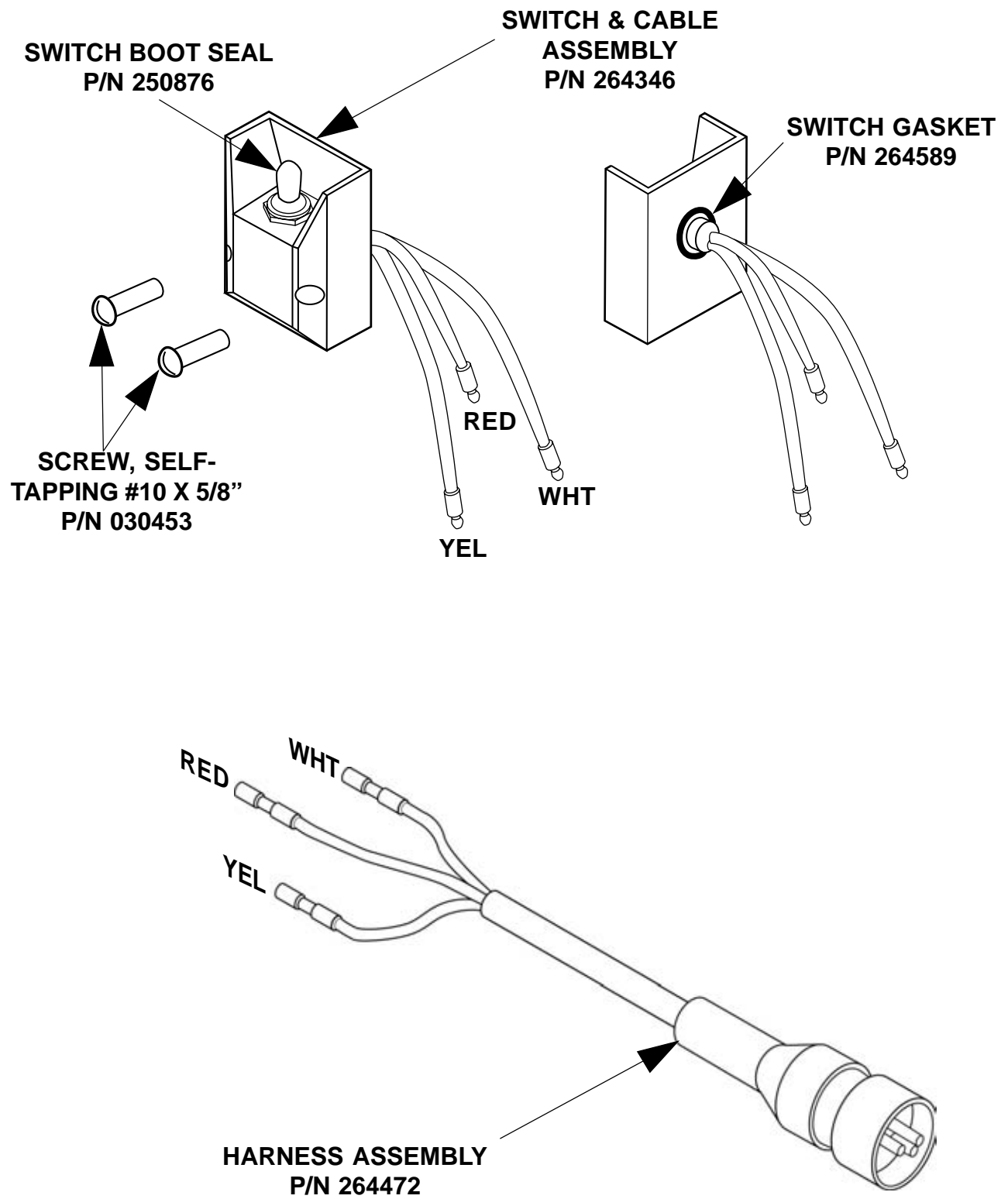

WIRE CONNECTIONS, GRAVITY DOWN

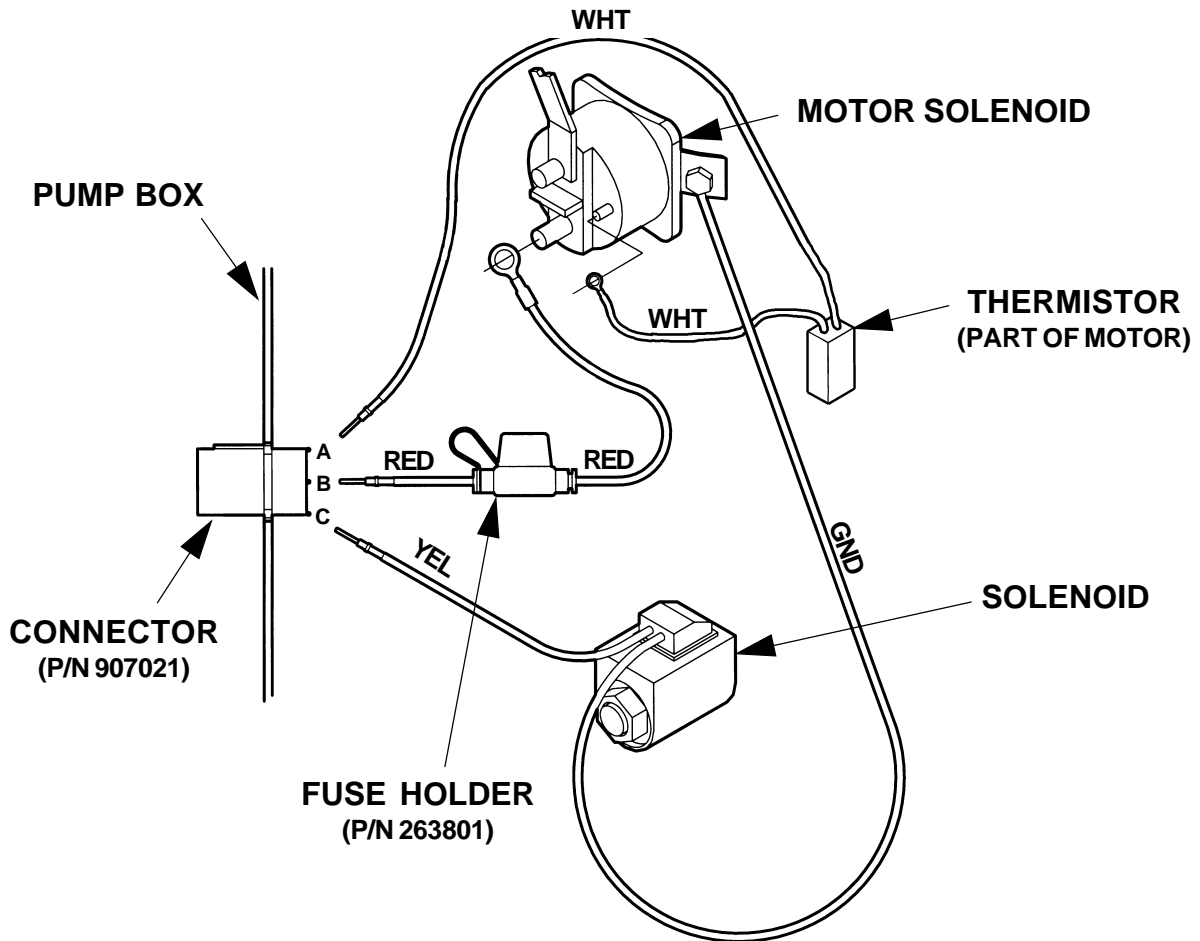
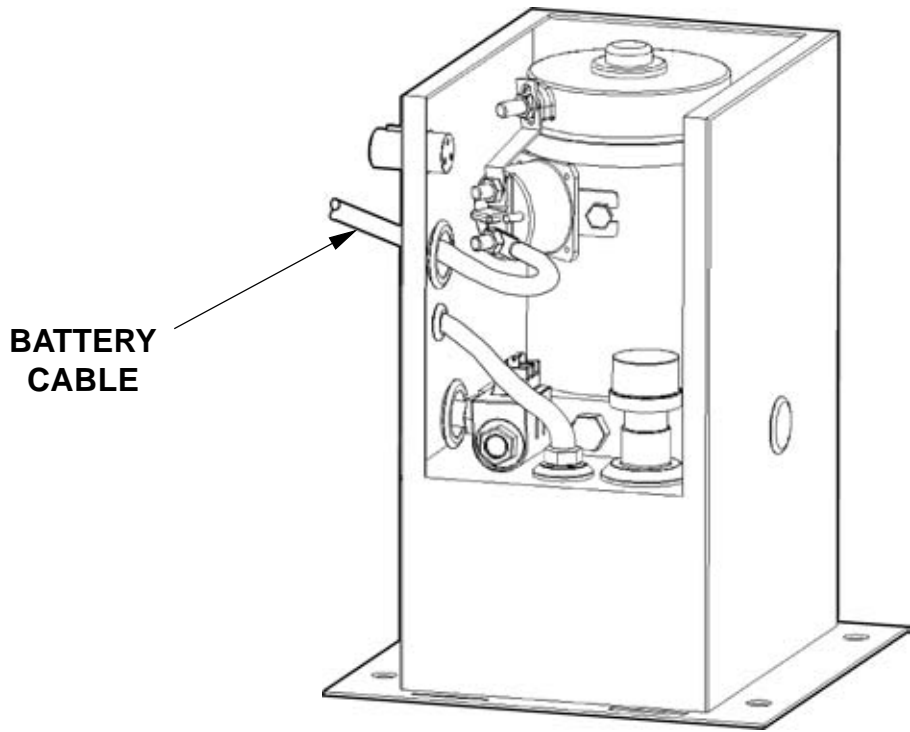

MAXON®

11921 Slauson Ave. Santa Fe Springs, CA. 90670 (800) 227-4116 FAX (888) 771-7713

LOW VOLTAGE / THERMAL SWITCH (LVTS) (IF EQUIPPED ON LIFTGATE)

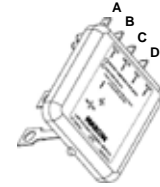
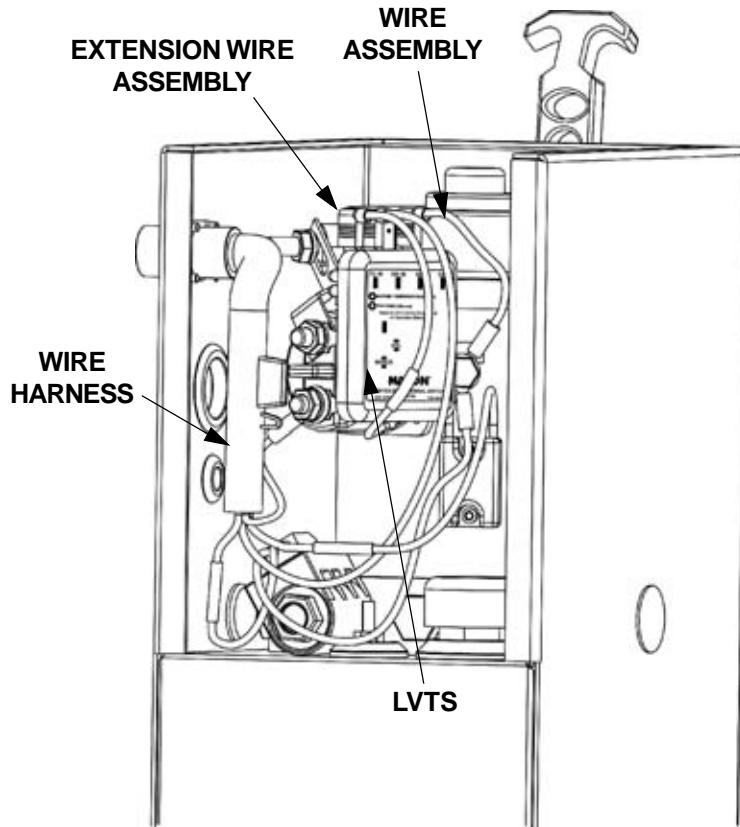

**LOW VOLTAGE/
THERMAL SWITCH
(LVTS)
P/N 905197**

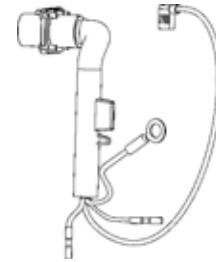

**WIRE HARNESS
P/N 264548**



**WIRE ASSEMBLY
P/N 264546**

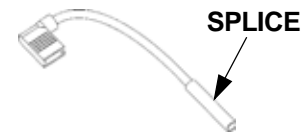
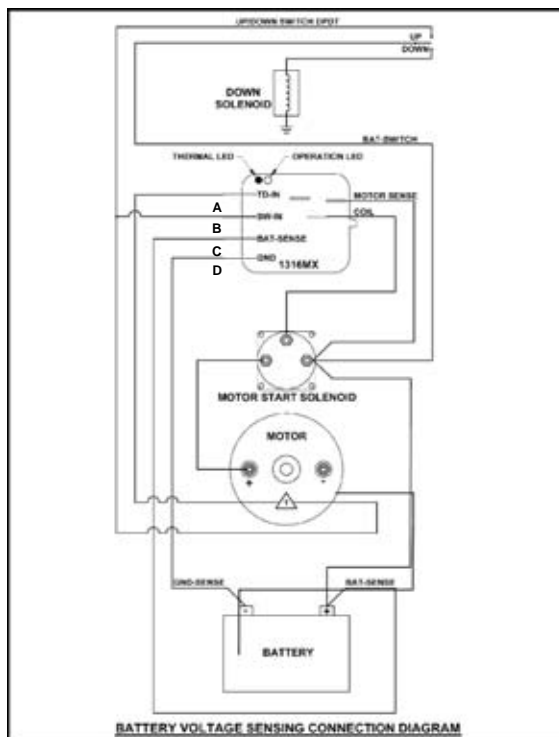

**EXTENSION
WIRE ASSEMBLY
P/N 264755**

ALUMINUM RETENTION RAMP (SPECIAL PROFILE OPTION)

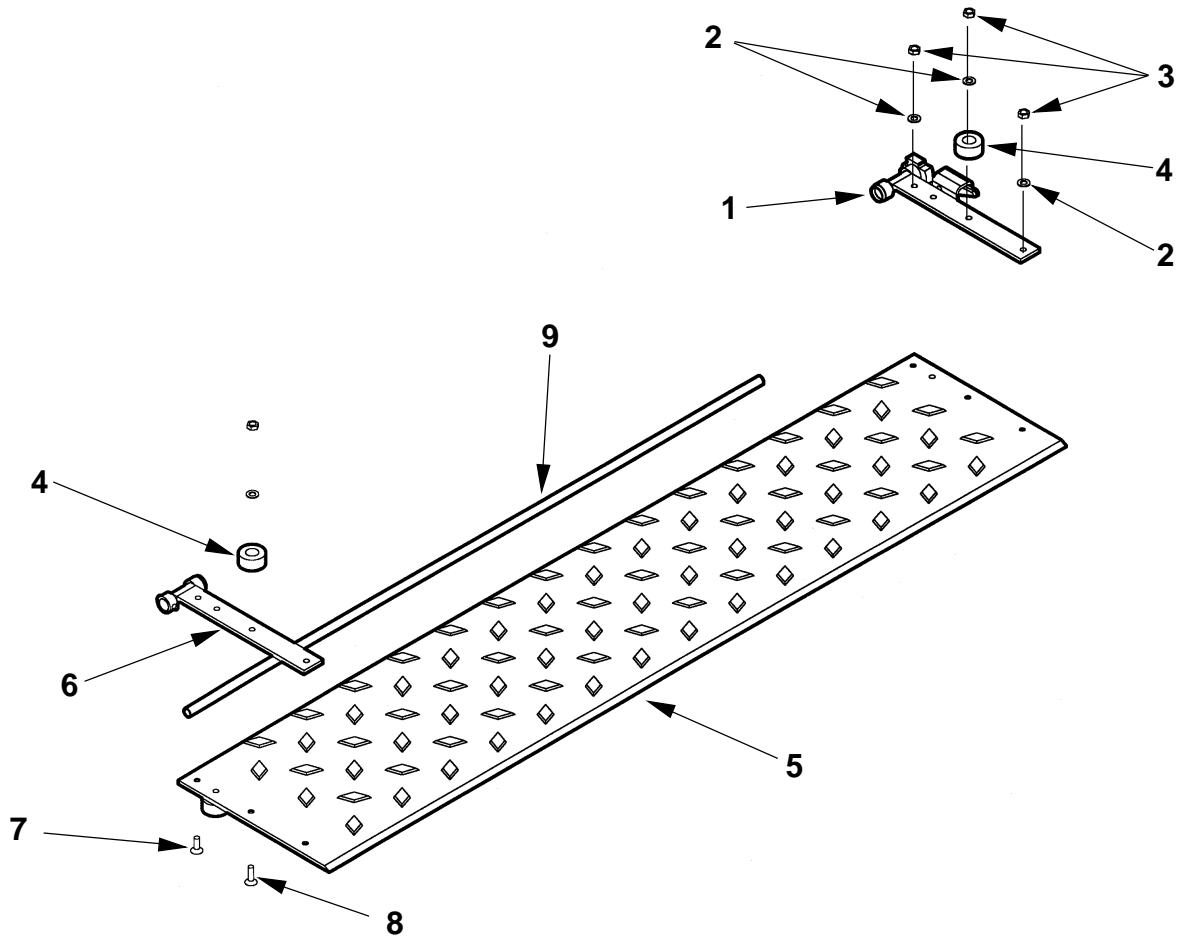

ITEM	QTY.	PART NO.	DESCRIPTION
1	1	253877	HINGE ASSEMBLY R.H
2	6	030556	WASHER FLAT 3/8"
3	6	030955	LOCK-NUT 3/8-16 UNC
4	2	253516	BUMPER 2" x 1" HIGH
5	1	253875	RAMP, ALUMINUM 3/8" x 10" x 69"
6	1	253876	HINGE ASSEMBLY L.H
7	4	040504	BOLT 3/8-16 UNC x 1-1/4" FLAT HEAD
8	2	030036	BOLT 3/8-16 UNC x 1-1/2" FLAT HEAD
9	1	225985	PIPE, 3/4" SCH. 80 x 60" LG

MAXON®

11921 Slauson Ave. Santa Fe Springs, CA. 90670 (800) 227-4116 FAX (888) 771-7713

ALUMINUM RETENTION RAMP - Continued (SPECIAL PROFILE OPTION)

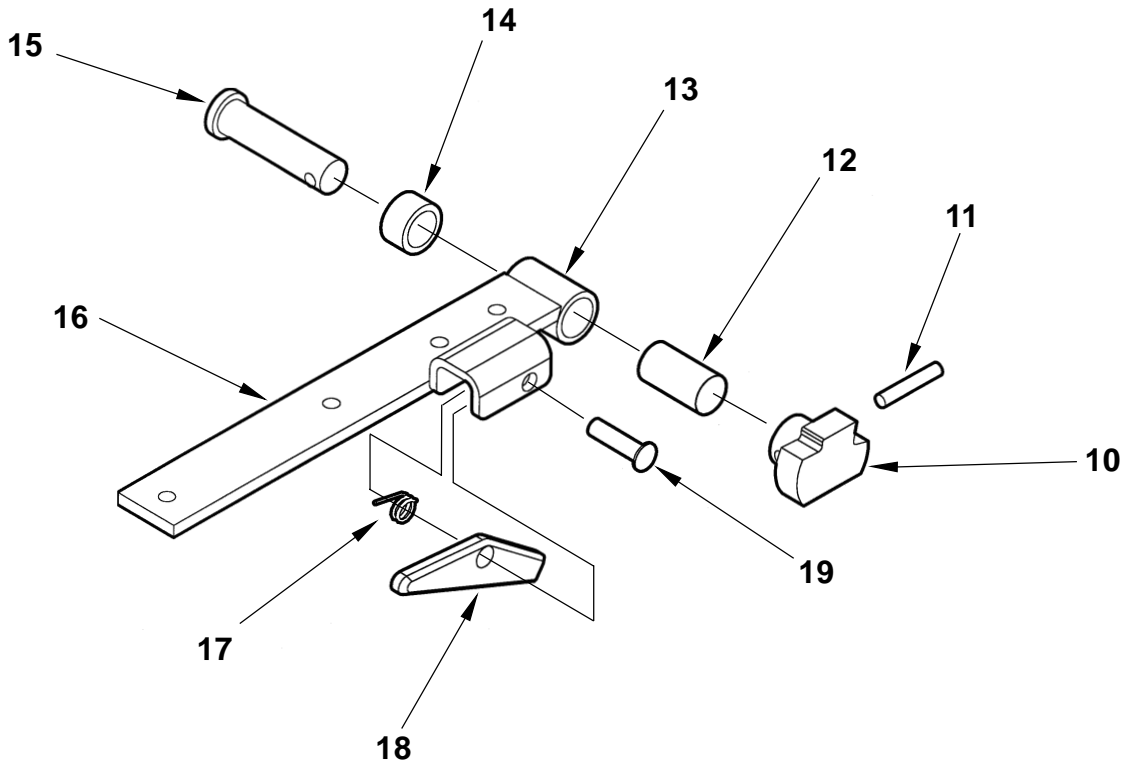

ITEM	QTY.	PART NO.	DESCRIPTION
10	1	221416	ROLL PIN 3/8" x 2"
11	1	253532	LOCK AND BUSHING WELDMENT
12	1	078202	PIN COLLAR x 3/4 LG
13	1	253541	BEARING, SELF-LUBE 1" DIA. x 2" LG
14	1	253517	BUSHING x 3/4"
15	1	253528	PIN WELDMENT
16	1	253879	HINGE ARM WELMENT R.H
17	1	252460	TORSION SPRING
18	1	260147	LOCKING ARM ASSEMBLY
19	1	253538	PIN WELDMENT
20	1	030406	ROLL PIN 1/8" x 1" ZINC PLT. (NOT SHOWN)

LIQUID SEALANT APPLICATION

NOTE: Apply Sealant to NPT threads only!

1. Clean all threads with a soft brush and a suitable cleaning solvent.
2. Dry threads thoroughly with compressed air or shop towel.
3. Apply the Liquid Sealant (Compound PLS 2), to the external threads of the Male Connector.
4. Assemble the fitting and torque it to the prescribed value.
5. Check for leakage. If leakage exists, remove the fitting and return to Step # 1.
6. If fitting is loosened or removed, return to Step # 1.

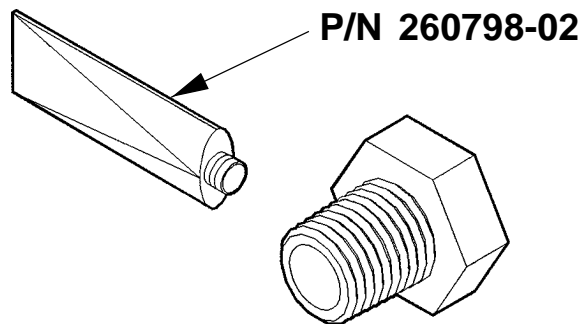

MAXON[®]

11921 Slauson Ave. Santa Fe Springs, CA. 90670 (800) 227-4116 FAX (888) 771-7713

TROUBLESHOOTING

PLATFORM WILL NOT RAISE

1. Verify that power is being supplied to the Solenoid Terminal "A". Recharge the battery if less than 12 volts.
2. Fill Reservoir to within 1/2" below the top with the recommended hydraulic fluid.
3. Touch a jumper wire to terminals "A" & "C". If motor runs, check Switch, Switch connections, and White wire. Correct the connections or replace the Switch.
4. Touch heavy jumper cables to terminals "A" & "B".
 - a. If motor runs, replace the motor solenoid.
 - b. If motor does not run, repair or replace the pump motor.
5. Check for structural damage. Replace worn parts.
6. Check filter in the pump Reservoir. Replace if necessary.
7. Check for a broken motor-to-pump coupler. Replace if necessary. A worn pump is extremely noisy, and needs replacement.
8. If equipped with a Low Voltage Thermal Switch (LVTS), system could shut down if the motor temperature or battery voltage level reach an unacceptable level. Read decal P/N 264776 located near the switch to determine what steps need to be taken to correct the problem.

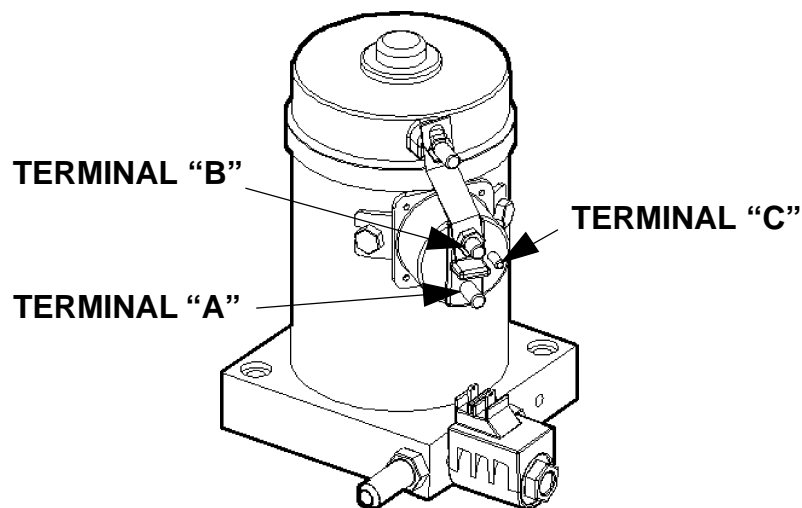

PLATFORM RAISES BUT LEAKS DOWN

1. Check Solenoid Valves for electrical shorts by holding a screwdriver approximately 1/4" from the top nut of the Solenoid. **(See FIG. 1)**. The solenoid should not draw the screwdriver to the nut with a magnetic force, unless the toggle switch is actuated. The Coil can be replaced by removing the Nut and Wires.

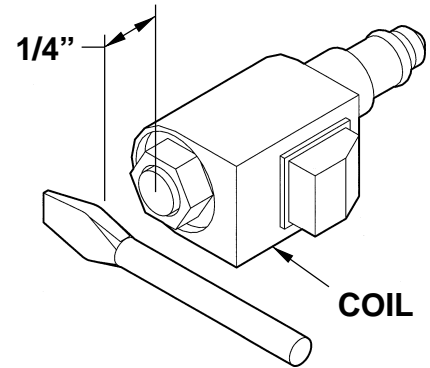

FIG. 1

2. Check the Valve Stem by removing the Coil Assembly, **(Item 1, FIG. 2)**. Unscrew the Valve Stem, **(Item 2, FIG. 2)**, from the Pump. Push on the plunger that is located inside the Valve Stem by inserting a paper clip in the end. If the Plunger does not move freely approximately 1/8", replace the Valve Stem.

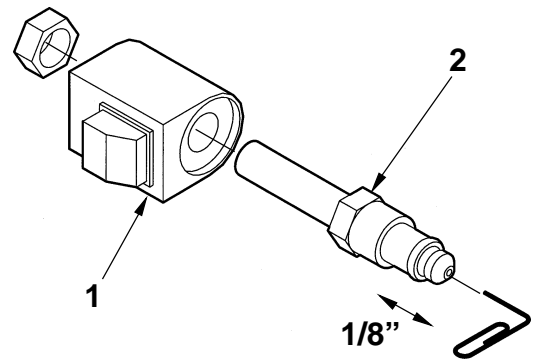

FIG. 2

3. Check the Hydraulic Cylinder. With the Platform on the ground, remove the Breather Plug or Vent Line from the Vent Port of the Cylinder. Raise the Platform to be level with the bed. If hydraulic fluid streams from the Vent Port, the Piston Seals are worn. Replace the Seals. **(See FIG. 3)**.

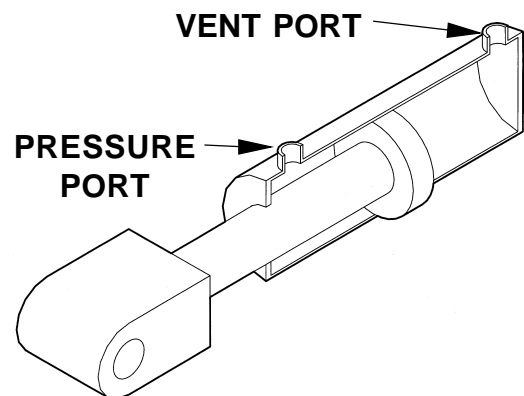

FIG. 3

PLATFORM RAISES PARTIALLY AND STOPS

- 1.** Lower the opened Platform to the ground. Fill the Reservoir to within 1” from the top with the recommended Hydraulic Fluid.
- 2.** Verify that the Battery shows 12 volts or better under load from pump motor. The use of a voltage load tester is recommended.
- 3.** Check for Structural damage, or lack of lubrication. Replace worn parts.
- 4.** Check Filter in the Pump Reservoir. Replace if necessary.
- 5.** Check for a broken motor-to-pump coupler. Replace if necessary. A worn pump is extremely noisy, and needs replacement.
- 6.** If equipped with a Low Voltage Thermal Switch (LVTS), system could shut down if the motor temperature or battery voltage level reach an unacceptable level. Read decal P/N 264776 located near the switch to determine what steps need to be taken to correct the problem.

MAXON[®]

11921 Slauson Ave. Santa Fe Springs, CA. 90670 (800) 227-4116 FAX (888) 771-7713

LIFTGATE WILL NOT LIFT RATED CAPACITY

1. Verify that the Battery shows 12 volts or better under load from pump motor. The use of a voltage load tester is recommended.
2. Check for Structural damage or lack of lubrication. Replace worn parts.

3. Check the Hydraulic Cylinder (**FIG. 1**).

With the Platform on the ground, remove the Breather Plug or Vent Line from the Vent Port of the Cylinder. Raise the Platform. If hydraulic fluid streams from the Vent Port, the Piston Seals are worn. Replace the Seals.

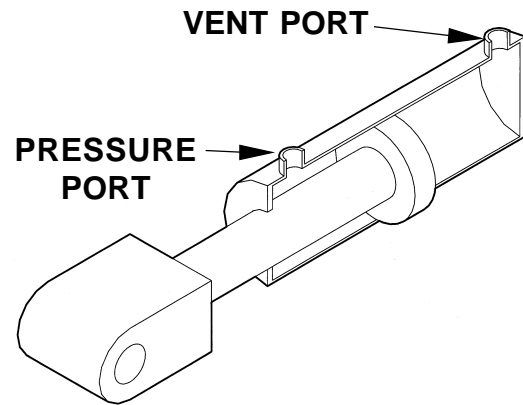

FIG. 1

4. With Platform on the ground, remove the pressure hose and fitting from the Pump and replace it with a 0-3000 PSI Pressure Gauge. Hold the switch in the "UP" position. Adjust the Relief Valve on the side of the Pump until the gauge shows 2800 to 3000 PSI. (**See FIG. 2.**)

5. If Pump cannot produce 2800-3000 PSI with a minimum of 12 Volts available, the Pump is worn and needs to be replaced.

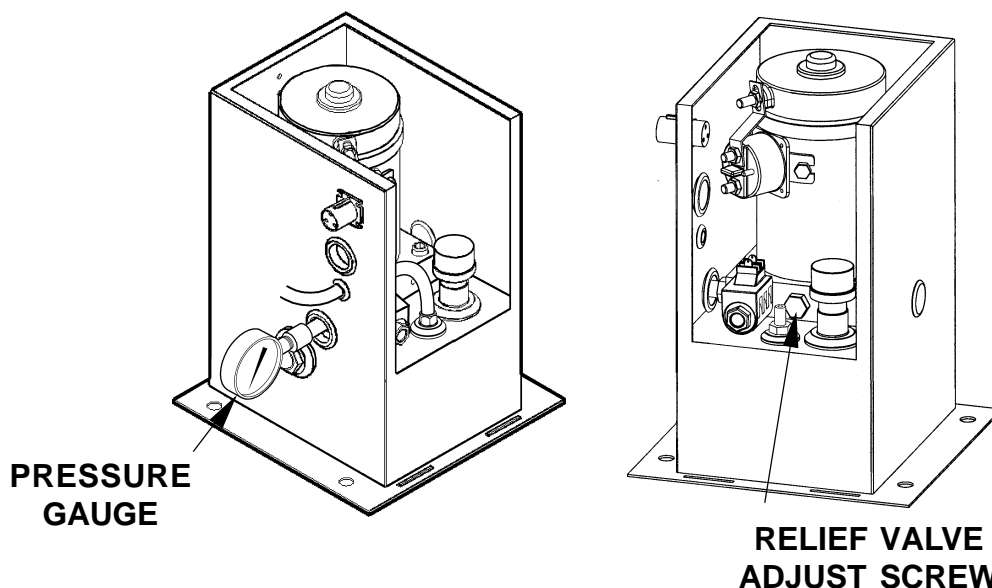

FIG. 2

PLATFORM RAISES SLOWLY

1. Verify that power is being supplied to Terminal "A". Recharge the battery if less than 12 Volts registers on the Voltage Tester. (See FIG. 1.)

2. Lower the opened Platform to the ground. Fill the Pump Reservoir to within 1" from the top with the recommended hydraulic fluid.

3. Verify the Pump Motor is grounded to the vehicle frame.

4. Check for leaking hoses and fittings. Tighten or replace as required.

5. Check for structural damage or lack of lubrication. Replace worn parts.

6. Check the Filter in the Pump Reservoir. Replace if necessary.

7. With Platform on the ground, remove the pressure hose and fitting from the Pump and replace it with a 0-3000 PSI Pressure Gauge. Hold the switch in the "UP" position. Adjust the Relief Valve on the side of the Pump until the gauge shows 2800 to 3000 PSI (See FIG. 2).

8. With the Platform on the ground, remove breather plug or vent line from vent port of cylinder. Raise the Platform to bed level. If hydraulic fluid streams from the Vent Port, the Piston Seals are worn. (See FIG. 3) Replace the Seals.

9. Check the Flow Control Valve. The arrow on the valve shows the direction of flow that is restricted, and Must point back to the Pump. (See FIG. 3)

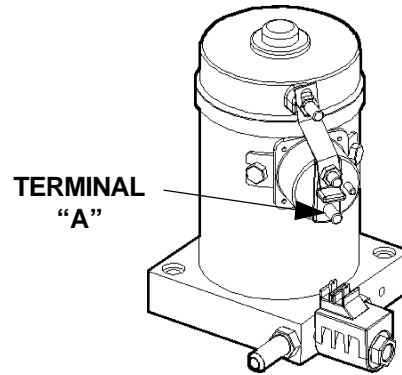

FIG. 1

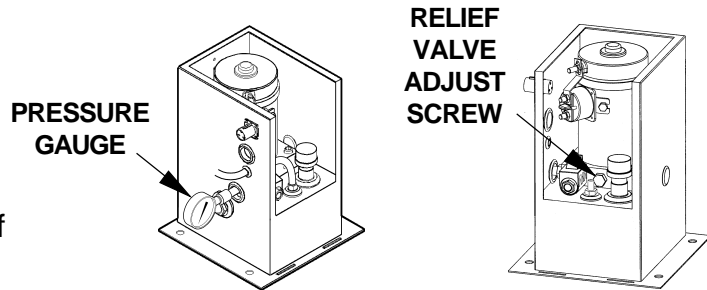

FIG. 2

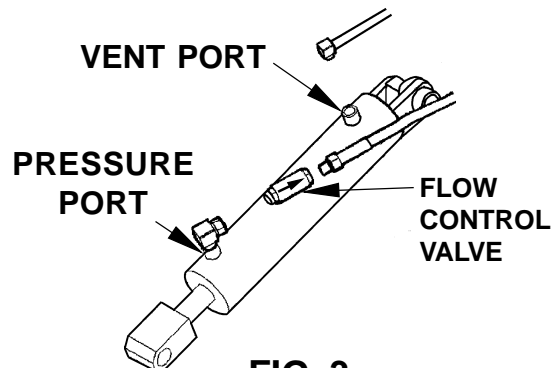

FIG. 3

PLATFORM WILL NOT LOWER

1. Verify that power is being supplied to the Solenoid Terminal "A" (Ref. FIG. 1). Recharge the battery if less than 12 volts.

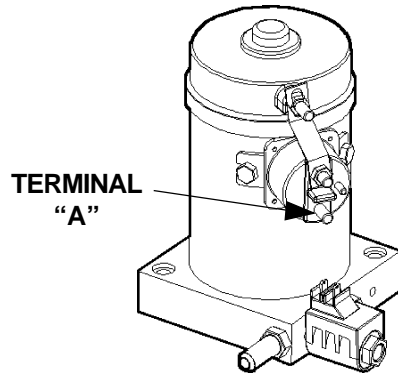

FIG. 1

2. Check for structural damage or lack of lubrication. Replace worn parts.
3. Check Solenoid Valve for power by holding a screwdriver approximately 1/4" from the top nut of the Solenoid. Energize the unit. (See FIG. 2). A good solenoid will draw the screwdriver to the nut by a magnetic force. The Coil can be replaced by removing the Nut and Wires.
4. Check the Valve Stem by removing the Coil Assembly, (Item 1, FIG. 3). Unscrew the Valve Stem, (Item 2, FIG. 3), from the Pump. Push on the plunger that is located inside the Valve Stem by inserting a paper clip in the end. If the Plunger does not move freely approximately 1/8", replace the Valve Stem.
5. If equipped with a Low Voltage Thermal Switch (LVTS), system could shut down if the motor temperature or battery voltage level reach an unacceptable level. Read decal P/N 264776 located near the switch to determine what steps need to be taken to correct the problem.

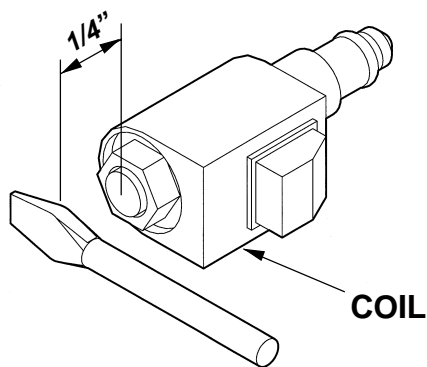

FIG. 2

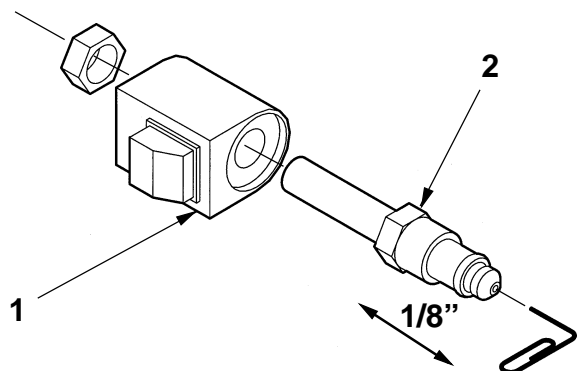

FIG. 3