

M-97-37
REV. ~
DEC. 1997

OPERATION MANUAL

TUK-A-WAY[®]

LIFT GATE SERIES

80-3LM, 80-4LM

MAXON[®]
LIFT CORP.

11921 Slauson Avenue.
Santa Fe Springs, CA. 90670
(800) 227-4116

MAXON[®]

LIFT CORP.

**11921 Slauson Ave.
Santa Fe Springs, CA. 90670**

CUSTOMER SERVICE:

TELEPHONE (562) 464-0099 TOLL FREE (800) 227-4116

FAX: (888) 771-7713

**NOTE: Check with Customer Service for updated versions
of Manuals on an annual basis.**

WARRANTY POLICY & PROCEDURE

NEW LIFTGATE WARRANTY

Term of Warranty: 2 Years from Date of In-Service

Type of Warranty: Full Parts and Labor

MAXON agrees to replace any components which are found to be defective during the first 2 years of service, and will reimburse for labor based on MAXON's Liftgate Warranty Flat Rate Labor Schedule. (Call MAXON Customer Service for a copy).

All claims for warranty must be received within 30 Days of the repair date, and include the following information:

1. Liftgate Model Number
2. Liftgate Serial Number
3. Detailed Description of Problem
4. Corrective Action Taken, and Date of Repair.
5. Parts used for Repair, Including MAXON Part Number(s).
6. MAXON R.M.A. # and/or Authorization # if applicable (see below).
7. Person contacted at MAXON if applicable.

All warranty repairs must be performed by an authorized MAXON warranty station. For major repairs, MAXON Customer Service must be notified and an "Authorization Number" obtained. Major repairs would generally be considered repairs made to the structural assembly of the liftgate and/or repairs not outlined in the MAXON Liftgate Warranty Flat Rate Schedule.

Major components (i.e. hydraulic pumps, cylinders, valves, or failed structural parts) must be returned, freight pre-paid, prior to the claim being processed. To ensure timely processing of these warranty claims, an R.M.A. (Returned Merchandise Authorization) number must be obtained from MAXON Customer Service prior to the return of any defective part. Defective Parts must be returned within 60 days of the claim date for consideration to:

**MAXON Lift Corp.
16205 Distribution Way, Cerritos, CA 90703
Attn: RMA#__**

MAXON's warranty policy does not include the reimbursement for travel time, towing, vehicle rental, service calls, oil, batteries, defects due to misuse or abuse, or loss of income due to downtime. Fabrication of parts, which are available from MAXON, are also not covered.

MAXON's Flat Rate Labor Schedule takes into consideration the time required for diagnosis of a problem.

PURCHASE PART WARRANTY

Term of Warranty: 1 Year from Date of Purchase

Type of Warranty: Part Replacement

MAXON will guarantee all returned genuine replacement parts upon receipt and inspection of parts and invoice.

Table of Contents

WARNING	PAGE 4
DECALS, 80 SERIES	PAGE 5
OPENING THE PLATFORM	PAGE 6
RAISING THE PLATFORM	PAGE 7
LOWERING THE PLATFORM	PAGE 8
STOWING THE PLATFORM.....	PAGE 8
LOADING THE PLATFORM.....	PAGE 9

WARNING

1. Read the **Operator's Manual** and understand it thoroughly before operating this unit.
2. Read the urgent warning decal on the side of the vehicle close to the unit before operating.
3. If decals are dirty, clean them. If decals are defaced or missing, replace them. **Free replacements** are available from the manufacturer. See information at the end of the Warnings !
4. Be aware that the safety and location of other people or objects should be considered before operation of this unit. Stand to one side of platform while operating this unit.
5. Do not stand under, or have any foreign object under the Platform when lowering. **Be sure that the lowering of the Platform and/or Flipover will miss your feet!**
6. Keep fingers, hands, arms, legs, and feet clear of moving parts when operating this unit.
7. If Platform is used as a ramp between vehicle and dock, **DO NOT ALLOW ANY TRANSFER OF LOADS TO EXCEED THE RATED CAPACITY OF THIS UNIT!**
8. Do not allow children to ride, play with, or operate this unit.
9. In the event of an emergency while operating the unit, release the toggle switch and the unit will stop immediately.
10. A properly installed Lift should operate smoothly and the only noise during the operation of this unit should be from the Pump Unit during the raising of the Platform. Any scraping, grating or audible indications of rough operation will need investigating. The cause will need resolving before any further deterioration of performance occurs.

Use only **Maxon Authorized Parts** for replacement. Replacement parts should be ordered from:

MAXON LIFT CORP. Parts Department
11921 Slauson Ave., Santa Fe Springs, Ca. 90670
Phone: (800) 227-4116

DECALS, 80 SERIES

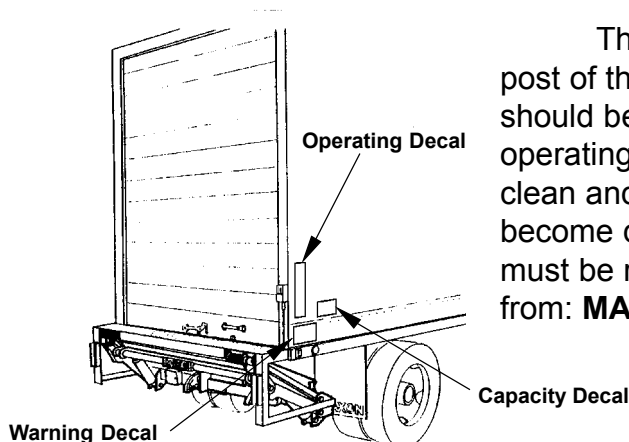

These Decals are located on the rear corner post of the vehicle, at the control position. They should be read completely and understood before operating the Lift Gate. They should also be kept clean and readable at all times. If any decal should become detached from the vehicle, or defaced, it must be replaced. Free replacements are available from: **MAXON Lift Corp.**, Parts Dept.

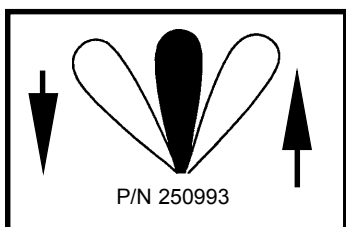

CAPACITY DECALS	
SIZE	PART NO.
3000 LBS.	220388
4000 LBS.	220389

WARNING

READ CAREFULLY

- Improper operation of this Lift can result in serious personal injury. Do not operate unless you have been properly instructed and have read, and are familiar with the operating instructions. If you do not have a copy of the instructions, please obtain them from your employer, distributor, or lessor, before you attempt to operate Lift.
- Be certain that the vehicle is properly and securely braked before using the Lift.
- Always inspect this Lift for maintenance or damage before using it. If there are signs of improper maintenance, damage to vital parts, or slippery Platform surface, do not use the Lift until these problems have been corrected.
- Do not overload the Lift. The load limit is based on evenly distributed cargo over the entire Platform surface. If you are using a pallet jack, be sure it can be maneuvered safely. Do not operate a forklift on the Platform or travel with the platform in an open position at any time.
- Load should be placed in a stable position close to the edge of the Platform nearest the truck. The heaviest portion of the load should never be placed beyond the center of the Platform away from the truck.
- Never allow yourself, a helper, or bystander to stand in a position where a falling load could land on either of you. Also do not allow your's or your helper's feet to be placed under any portion of the lowering Lift.
- If a helper is riding the Platform with you, make sure you are both doing so safely and that you are not in danger of coming in contact with any moving or potentially moving obstacles. USE GOOD COMMON SENSE. If load appears to be unsafe, do not lift or lower it.

MAXON LIFT CORP.
PART NO. 260008

OPERATING INSTRUCTIONS

GPT & 80-3/4 Units

- ①

Unhook Safety Chain First.
- ②

Activate Toggle Switch to Lower Stowed Lift Gate

This point must touch the ground
- ③

Open Platform
- ④

Open Flipover
- ⑤

Activate Toggle Switch to Raise or Lower Platform
- ⑥

To Tuck Unit Away after Use, Reverse Steps 1 thru 4

MAXON[®]

P/N 251838

MAXON[®] 11921 Slauson Ave. Santa Fe Springs, CA. 90670 (800) 227-4116 FAX (888) 771-7713

OPENING THE PLATFORM

1. Disengage Safety Chain Hook from the Lift Frame.

Safety Chain Hook

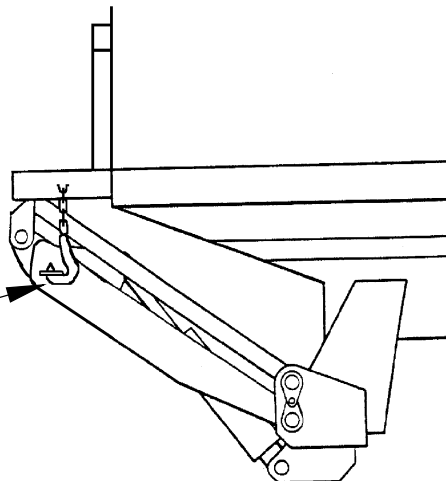

2. Standing clear of moving parts, lower Platform by pushing Toggle Switch to the "Down" arrow side shown on the Decal. When the lift touches the ground, release the switch.

NOTE:

In the event of an emergency during the operation of the unit, release the Control Switch which will **IMMEDIATELY STOP THE OPERATION OF THE UNIT.**

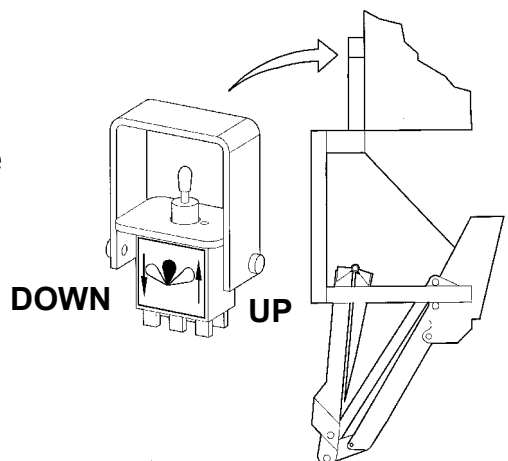

3. Keeping feet clear, unfold the Platform.

4. Keeping feet clear, unfold the Flipover to the ground.

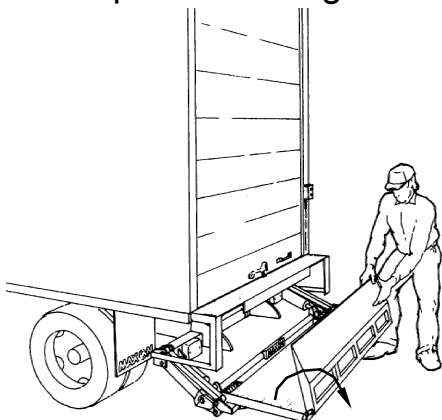
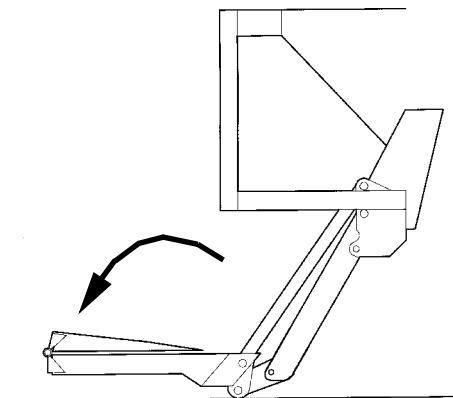

MAXON[®]

11921 Slauson Ave. Santa Fe Springs, CA. 90670 (800) 227-4116 FAX (888) 771-7713

RAISING THE PLATFORM

Push Toggle Switch in the "UP" position to raise the Platform. Platform and Flipover will raise to the Vehicle Bed.

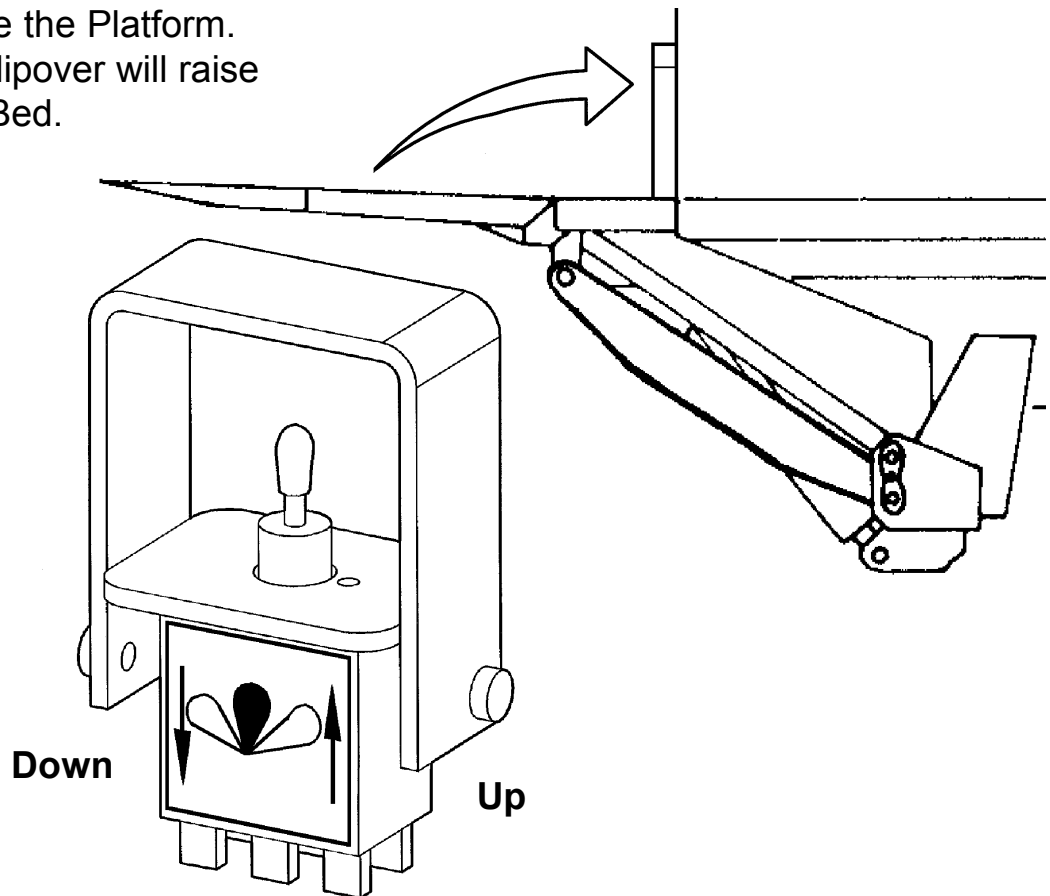

When the Platform reaches the bed height, release the "UP" switch. **DO NOT CONTINUE TO HOLD THE SWITCH IN ITS RAISED POSITION. THIS WILL BURN OUT THE PUMP MOTOR.**

LOWERING THE PLATFORM

1. Activate the toggle switch to the “DOWN” position to lower the Platform. KEEP FEET CLEAR OF DESCENDING PLATFORM.

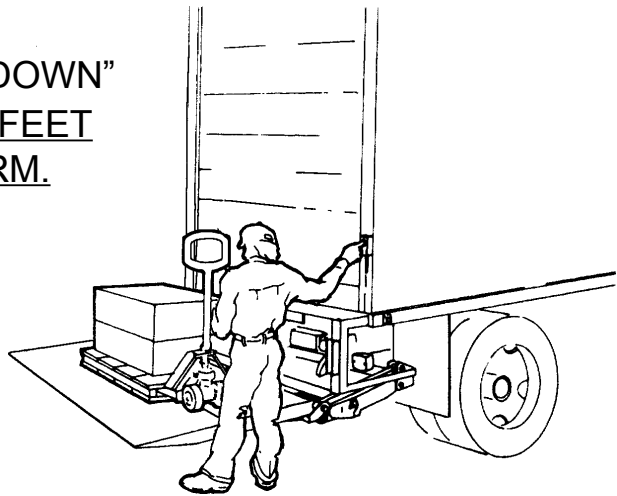
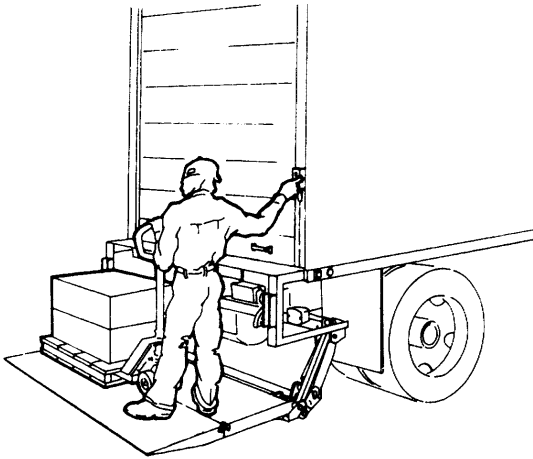

2. When lift touches the ground, release the toggle switch.

STOWING THE PLATFORM

Fold the Platform/Flipover by reversing the Opening Instructions. Standing clear of moving parts, raise the Platform by activating the “RAISE” switch. This should automatically fold the Platform in the Tuk-A-Way position under your vehicle. Once the Platform has stopped folding, release the switch. Engage the Safety Chain Hook from the Extension Plate to the Lift Frame as shown.

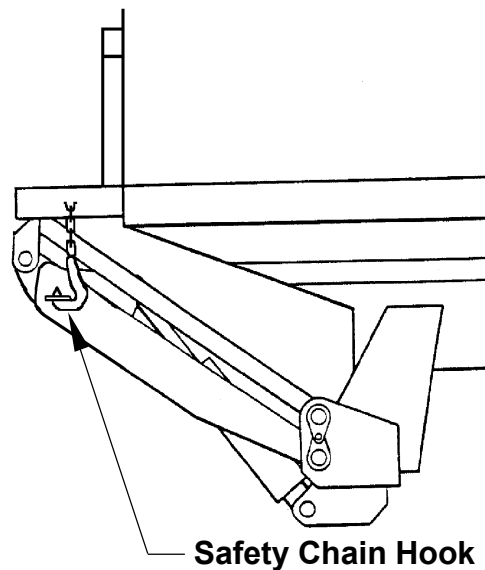

MAXON[®]

11921 Slauson Ave. Santa Fe Springs, CA. 90670 (800) 227-4116 FAX (888) 771-7713

LOADING THE PLATFORM

All loads must be placed as close to the edge of the Platform, nearest the vehicle floor as possible. No part of any load should be allowed to extend over the edges of the Platform. Never place the heaviest portion beyond the center of the Platform. Do not place unstable loads on the Platform. Do not allow any load to exceed the rated capacity for the unit.

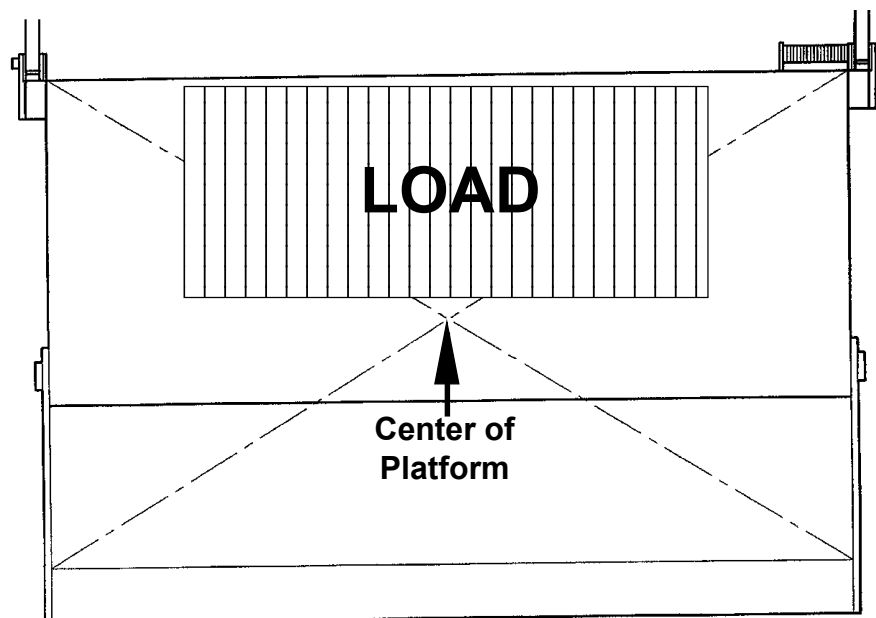

Before lifting load, check that there are no people close to the Liftgate, especially children. Accidents can occur when unstable loads topple off the lifting area and people are in close proximity to the lifting operation.