

MAXON®

M-97-15
REV. G
JANUARY 2003

MAINTENANCE 
GPT MANUAL

- GPT-25
- GPT- 3
- GPT- 4
- GPT- 5

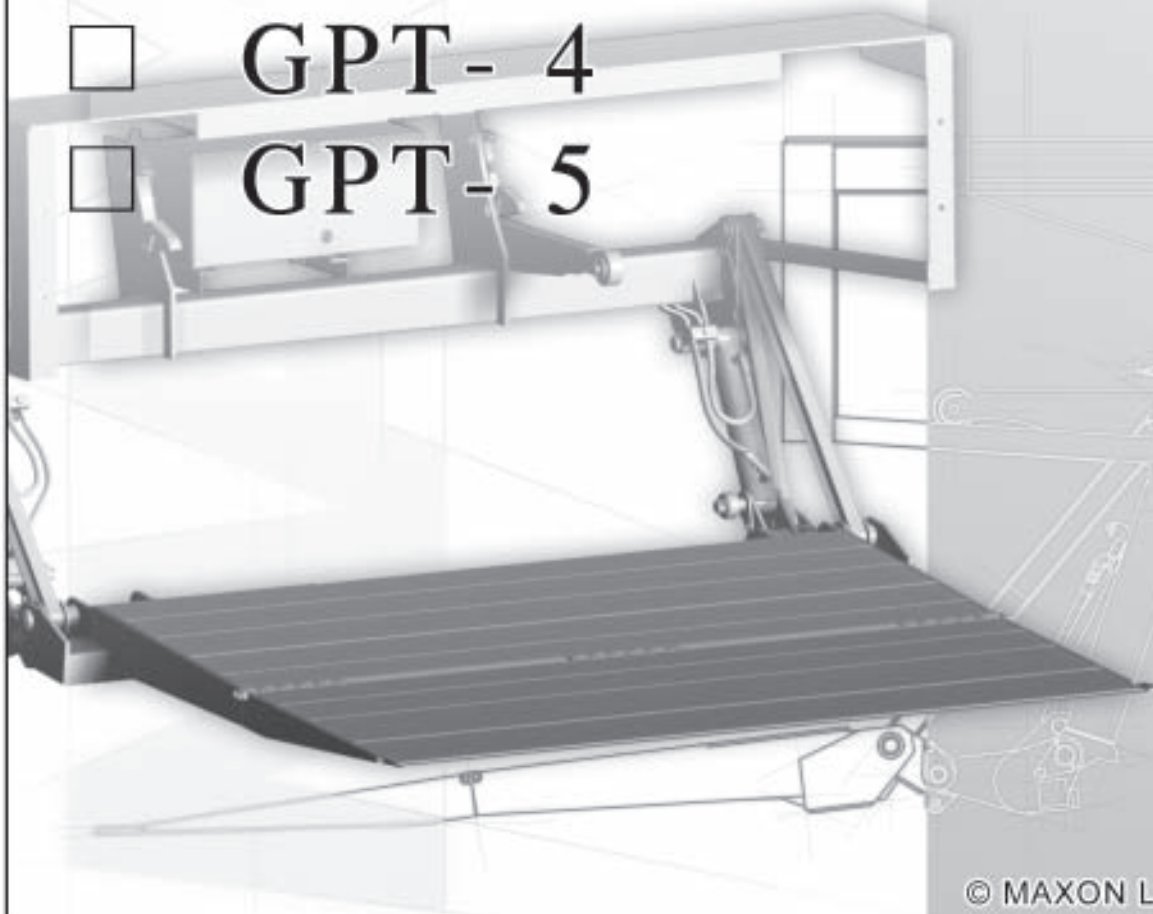

MAXON[®]

LIFT CORP.

11921 Slauson Ave.
Santa Fe Springs, CA. 90670

CUSTOMER SERVICE:

TELEPHONE (562) 464-0099 TOLL FREE (800) 227-4116

FAX: (888) 771-7713

NOTE: For latest version Manuals (and replacements), download
Manuals from Maxon's website at www.maxonlift.com.

WARRANTY/ RMA POLICY & PROCEDURE

LIFTGATE WARRANTY

Term of Warranty: 2 Years from Date of In-Service (In service date cannot exceed 3 months from ship date.)

Type of Warranty: Full Parts and Labor

This warranty shall not apply unless the product is installed, operated and maintained in accordance with MAXON Lift's specifications as set forth in MAXON Lift's Installation, Operation and Maintenance manuals. This warranty does not cover normal wear, maintenance or adjustments, damage or malfunction caused by improper handling, installation, abuse, misuse, negligence, or carelessness of operation. In addition, this warranty does not cover equipment that has had unauthorized modifications or alterations made to the product.

MAXON agrees to replace any components which are found to be defective during the first 2 years of service, and will reimburse for labor based on MAXON's Liftgate Warranty Flat Rate Schedule. (Copy of the Flat Rate is available at www.maxonlift.com.)

All warranty repairs must be performed by an authorized MAXON warranty facility. For any repairs that may exceed \$500, including parts and labor, MAXON's Technical Service Department must be notified and an "Authorization Number" obtained.

All claims for warranty must be received within 30 Days of the repair date, and include the following information:

1. Liftgate Model Number and Serial Number
2. The End User must be referenced on the claim
3. Detailed Description of Problem
4. Corrective Action Taken, and Date of Repair
5. Parts used for Repair, Including MAXON Part Number(s)
6. MAXON R.M.A. # and/or Authorization # if applicable (see below)
7. Person contacted at MAXON if applicable
8. Claim must show detailed information i.e. Labor rate and hours of work performed

Warranty claims can also be placed on-line at www.maxonlift.com. On-line claims will be given priority processing.

All claims for warranty will be denied if paperwork has not been received or claim submitted via Maxon website for processing by MAXON's Warranty Department within 30 days of repair date.

All components may be subject to return for inspection, prior to the claim being processed. MAXON products may not be returned without prior written approval from MAXON's Technical Service Department. Returns must be accompanied by a copy of the original invoice or reference with original invoice number and are subject to a credit deduction to cover handling charges and any necessary reconditioning costs. **Unauthorized returns will be refused and will become the responsibility of the returnee.**

Any goods being returned to MAXON Lift must be pre-approved for return, and have the R.M.A. number written on the outside of the package in plain view, and returned freight prepaid. All returns are subject to a 15% handling charge if not accompanied by a detailed packing list. Returned parts are subject to no credit and returned back to the customer.

Defective Parts requested for return must be returned within 30 days of the claim date for consideration to:

MAXON Lift Corp.
16205 Distribution Way, Cerritos, CA 90703

Attn: RMA#__

MAXON's warranty policy does not include the reimbursement for travel time, towing, vehicle rental, service calls, oil, batteries or loss of income due to downtime. Fabrication or use of non Maxon parts, which are available from MAXON, are also not covered.

MAXON's Flat Rate Labor Schedule takes into consideration the time required for diagnosis of a problem.

All Liftgates returned are subject to inspection and a 15% restocking fee. Any returned Liftgates or components that have been installed or not returned in new condition will be subject to an additional reworking charge which will be based upon the labor and material cost required to return the Liftgate or component to new condition.

PURCHASE PART WARRANTY

Term of Warranty: 1 Year from Date of Purchase.

Type of Warranty: Part replacement only

MAXON will guarantee all returned genuine MAXON replacement parts upon receipt and inspection of parts and original invoice.

All warranty replacements parts will be sent out via ground freight. If a Rush Shipment is requested all freight charges will be billed to the requesting party.

TABLE OF CONTENTS

WARNING	6
LIFTGATE TERMINOLOGY	7
SERVICE TIME CHART	8
PERIODIC MAINTENANCE CHECKLIST	11
CHANGING HYDRAULIC FLUID	11
ADJUSTMENTS	13
SADDLE ADJUSTMENT	14
REPLACING PLATFORM TORSION SPRING	15
PLATFORM ADJUSTMENT	16
PARTS BREAKDOWN	18
GPT ASSEMBLY	19
GPT-25/-3 MAIN FRAME ASSEMBLY	20
GPT-4/-5 MAIN FRAME ASSEMBLY	22
PLATFORM & FLIPOVER ASSY (NO CART STOP)	24
PLATFORM & FLIPOVER ASSY (SINGLE CART STOP)	25
FLIPOVER (SINGLE CART STOP)	26
PLATFORM & FLIPOVER ASSY (DUAL CART STOP)	27
DOCK BUMPER.....	29
HYDRAULIC COMPONENTS - POWER DOWN	30
PUMP BOX ASSEMBLY - POWER DOWN	31
CONTROL SWITCH AND POWER CABLE	32
DECALS	33

TABLE OF CONTENTS - Continued

SCHEMATICS	37
HYDRAULIC SCHEMATIC - POWER DOWN	38
ELECTRICAL SCHEMATIC - POWER DOWN	39
TROUBLESHOOTING	40
PLATFORM WILL NOT RAISE	41
PLATFORM RAISES BUT LEAKS DOWN	42
PLATFORM RAISES PARTIALLY AND STOPS	43
LIFTGATE WILL NOT LIFT RATED CAPACITY	44
PLATFORM RAISES SLOWLY	45
PLATFORM WILL NOT LOWER, LOWERS TOO SLOWLY, OR LOWERS TOO QUICKLY ..	46

Comply with the following **WARNINGS** while maintaining Liftgates. See Operation Manual M-97-16 for operating safety requirements.

WARNING

- Read and understand the instructions in this **Maintenance Manual** before performing maintenance on the Liftgate.
- Before operating the Liftgate, read and understand the operating instructions in **Operation Manual M-97-16**.
- Comply with all **WARNING** and instruction decals attached to the Liftgate.
- Keep decals clean and legible. If decals are defaced or missing, replace them. Free replacement decals are available from **Maxon Parts Department**.
- Consider the safety and location of bystanders and location of nearby objects when operating the Liftgate. Stand to one side of the platform while operating the Liftgate
- Do not allow untrained persons to operate the Liftgate.
- Do not stand under, or allow obstructions under the platform when lowering the Liftgate. **Be sure your feet are clear of the Liftgate.**
- **Keep fingers, hands, arms, legs, and feet clear of moving Liftgate parts (and platform edges) when operating the Liftgate.**
- **Correctly stow platform when not in use. Extended platforms could create a hazard for people and vehicles passing by.**
- **Disconnect Liftgate power cable from battery** before repairing or servicing Liftgate.
- Wear appropriate safety equipment such as protective eyeglasses, faceshield and clothing while performing maintenance on the Liftgate and handling the battery. Debris from drilling and contact with battery acid may injure unprotected eyes and skin.
- Be careful working by an automotive type battery. Make sure the work area is well ventilated and there are no flames or sparks near the battery. Never lay objects on the battery that can short the terminals together. If battery acid gets in your eyes, immediately seek first aid. If acid gets on your skin, immediately wash it off with soap and water.
- If an emergency situation arises (vehicle or Liftgate) while operating the Liftgate, release the control Toggle Switch and the Liftgate will stop.
- A correctly installed Liftgate operates smoothly and reasonably quiet. The only noticeable noise during operation comes from the pump unit while the platform is raised. Listen for scraping, grating and binding noises and correct the problem before continuing to operate Liftgate.
- If it is necessary to stand on the platform while maintaining the Liftgate, keep your feet and any objects clear of the inboard edge of the platform. Your feet or objects on the platform could be trapped between the platform and the Liftgate extension plate.
- Never perform unauthorized modifications on the Liftgate. Modifications may result in early failure of the Liftgate and may create hazards for Liftgate operators and maintainers.
- Use only **Maxon Authorized Parts** for replacement parts. Provide Liftgate model and serial number information with your parts order. Order replacement parts from:

MAXON LIFT CORP. Customer Service
11921 Slauson Ave., Santa Fe Springs, CA 90670
Phone: (800) 227-4116

- To order parts by e-mail, submit orders to partssales@maxonlift.com.

LIFTGATE TERMINOLOGY (GPT SERIES)

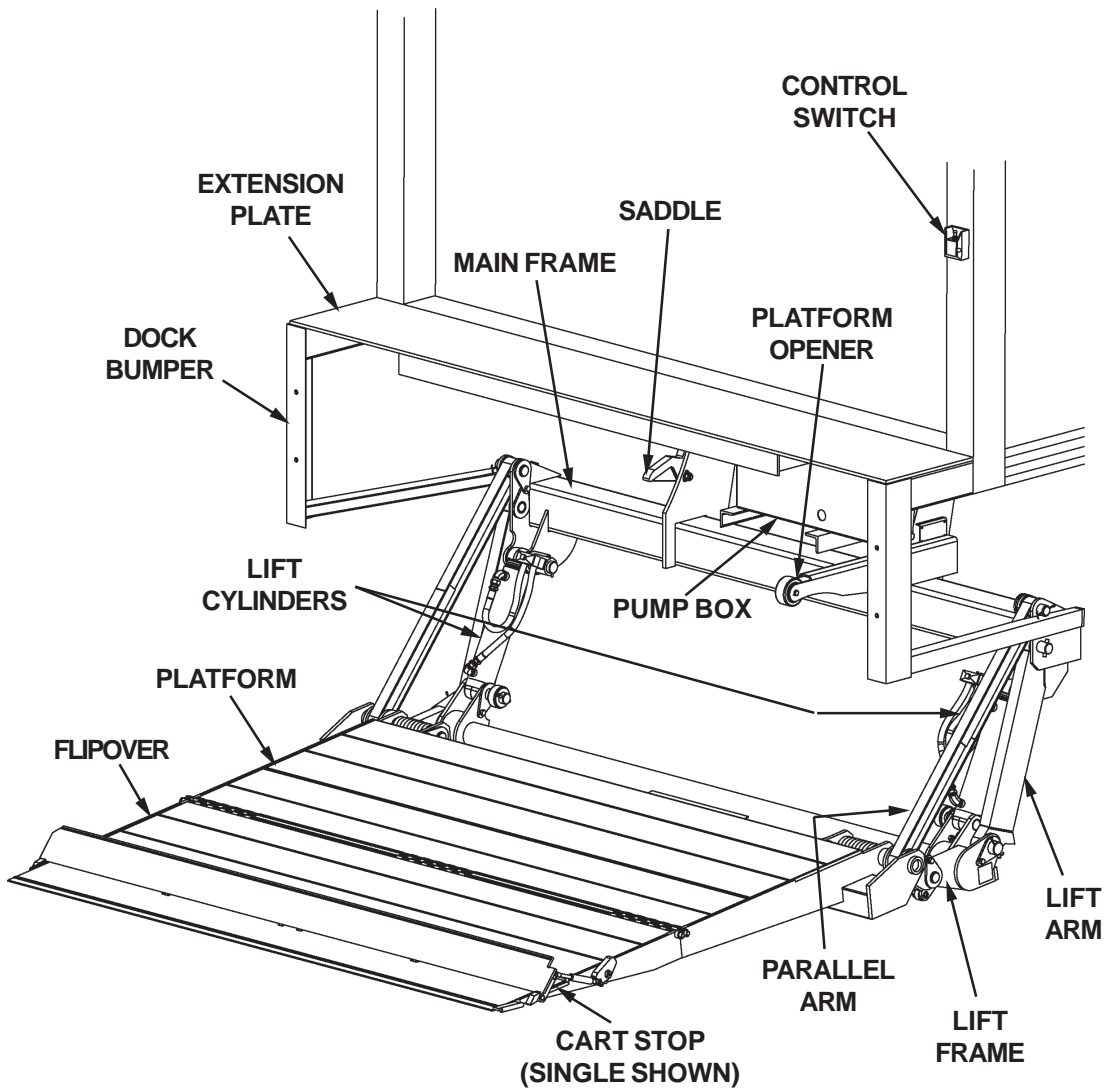

11921 Slauson Ave. Santa Fe Springs, CA. 90670 (800) 227-4116 FAX (888) 771-7713
MAXON

SERVICE TIME CHART

MAXON[®]

11921 Slauson Ave. Santa Fe Springs, CA. 90670 (800) 227-4116 FAX (888) 771-7713

STRUCTURAL SERVICE TO BE PERFORMED	TIME REQ'D. (HOURS)
CHANGE PLATFORM PINS (EACH)	.50
CHANGE ALL PINS	3.00
CHANGE GREASELESS BUSHINGS (EACH)	.25
CHANGE PLATFORM TORSION SPRING	1.00
CHANGE EXTENSION PLATE	1.50
CHANGE LIFTFRAME ASSEMBLY	1.00
CHANGE PARALLEL ARM (EACH)	.50
CHANGE SHACKLES (EACH)	.50
CHANGE PLATFORM OPENER	.50
CHANGE PLATFORM LOCKING LATCH	.50
CHANGE ENTIRE PLATFORM	2.00
CHANGE PLATFORM MAIN SECTION	1.50
CHANGE PLATFORM FOLDING SECTION (ALUMINUM)	1.00
REPLACE FOLDING SECTION HINGE PIN (ALUMINUM)	2.00
ADJUST PLATFORM SLOPE	.50

ELECTRICAL SERVICE TO BE PERFORMED	TIME REQ'D. (HOURS)
CHANGE MOTOR	1.00
CHANGE MOTOR SOLENOID	.50
CHANGE SOLENOID VALVE COIL (EACH)	.50
CHANGE POWER PACK, COMPLETE	1.00
CHANGE OUTSIDE SWITCH ASSEMBLY	.50
CHANGE CIRCUIT BREAKER	.50
CHANGE TOGGLE SWITCH (EACH)	.50
CHANGE WIRING HARNESS OUTSIDE	1.00

HYDRAULIC SERVICE TO BE PERFORMED	TIME REQ'D. (HOURS)
CHANGE PUMP ASSEMBLY	1.00
CHANGE PUMP RESERVOIR	1.00
CHANGE AUXILIARY HAND PUMP	1.00
RESET PUMP AND RELIEF VALVE PRESSURE	.50
ADJUST LOWERING SPEED	.25
CHANGE EXTERNAL FLOW CONTROL VALVE	.50
CHANGE/CLEAN CARTRIDGE VALVE	1.00
CHANGE LIFT CYLINDER (EACH)	1.00
CHANGE EXTERNAL HYDRAULIC HOSES (EACH)	.25
CHANGE RETURN LINE (EACH)	.50

MAXON[®] 11921 Slauson Ave. Santa Fe Springs, CA. 90670 (800) 227-4116 FAX (888) 771-7713

PERIODIC MAINTENANCE CHECKLIST



WARNING

Never operate the Liftgate with parts loose or missing.

Annually

Visually check the entire Liftgate for excessively worn parts and broken welds, especially the Hinge Pins. See **PARTS BREAKDOWN** section for replacement parts. Also, do the **Semi-annual** and **Quarterly Maintenance** checks.

Semi-annually

Visually check the Platform Hinge Pins for excessive wear and broken welds. See **PARTS BREAKDOWN** section for replacement parts. Also, do the **Quarterly Maintenance** checks.

Quarterly

Check the Hydraulic Fluid level in the Pump Reservoir. If hydraulic fluid must be added, select the correct grade of fluid to use at your location.

+20 to +150 Degrees F	- Grade ISO 32
Below + 20 Degrees F	- Grade ISO 15

If Hydraulic Fluid appears contaminated, refer to the **CHANGING HYDRAULIC FLUID** procedure on following page.

Keep track of the grade of Hydraulic Fluid in the Pump Reservoir and never mix two different grades of fluid.

Check all Hoses and Fittings for chaffing and fluid leaks. Replace if necessary.

Check electrical wiring for chaffing and make sure wiring connections are tight and free of corrosion.

Check that all **WARNING and instruction decals** are in place and legible.

Check that all roll pins are in place and protrude evenly from both sides of Hinge Pin collar. Replace roll pins if necessary.

MAXON[®]

11921 Slauson Ave. Santa Fe Springs, CA. 90670 (800) 227-4116 FAX (888) 771-7713

CHANGING HYDRAULIC FLUID

CAUTION

Keep dirt, water and other contaminants from entering the hydraulic system. Before opening the hydraulic fluid reservoir filler cap, drain plug and hydraulic lines, clean up contaminants that can get in the openings. Also, protect the openings from accidental contamination.

NOTE: To prevent spills, drain used hydraulic fluid through a funnel into waste fluid container.

1. Place empty 5 Gallon Bucket under Drain Plug.
2. Open and raise Platform to vehicle bed height. Remove the Drain Plug (**FIG. 1A**). Drain hydraulic fluid.
3. Disconnect the White Wire (**FIG. 1B**) from Motor Solenoid. Lower the Platform while draining the remaining hydraulic fluid from system. Re-install Drain Plug. Reconnect the White Wire to Motor Solenoid.
4. Remove Filler Cap and refill reservoir (**FIG. 1B**) to 2" from top. Use correct grade of hydraulic fluid for your location.

+20 to +150 Degrees F - Grade ISO 32
Below + 20 Degrees F - Grade ISO 15

5. Raise Platform to vehicle bed height. Check hydraulic fluid again and, if needed, add more hydraulic fluid (**FIG. 1A**).

6. Re-install Filler Cap (**FIG. 1B**).

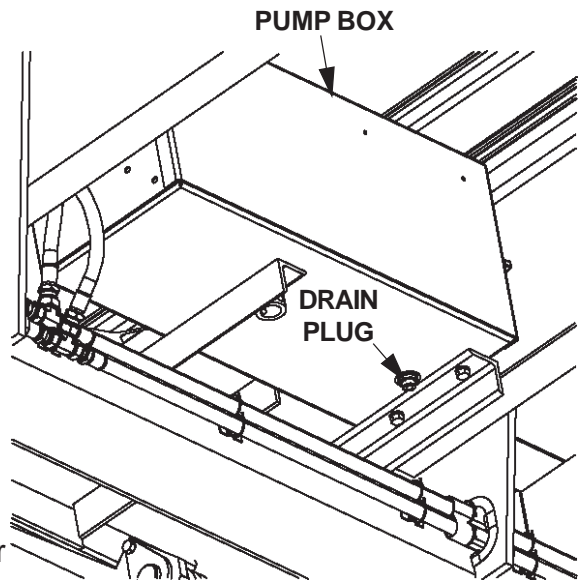

FIG. 1A

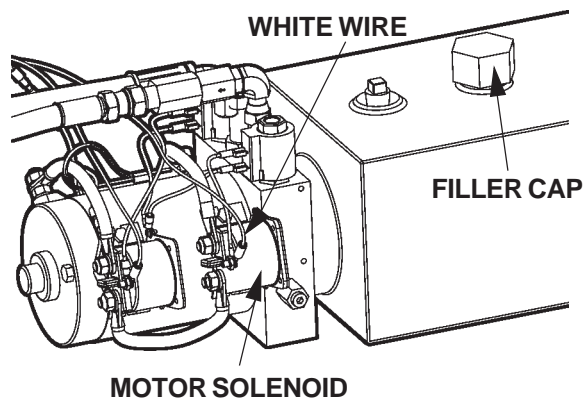

FIG. 1B

MAXON[®]

11921 Slauson Ave. Santa Fe Springs, CA. 90670 (800) 227-4116 FAX (888) 771-7713

THIS PAGE INTENTIONALLY LEFT BLANK

ADJUSTMENTS

SADDLE ADJUSTMENT

1. Make sure Platform is at ground level.

2. Remove bolts, lock nuts (**FIG. 2B**), and Saddle from Right Hand side (RH) Mounting Plate. Repeat step for Left Hand (LH) side.

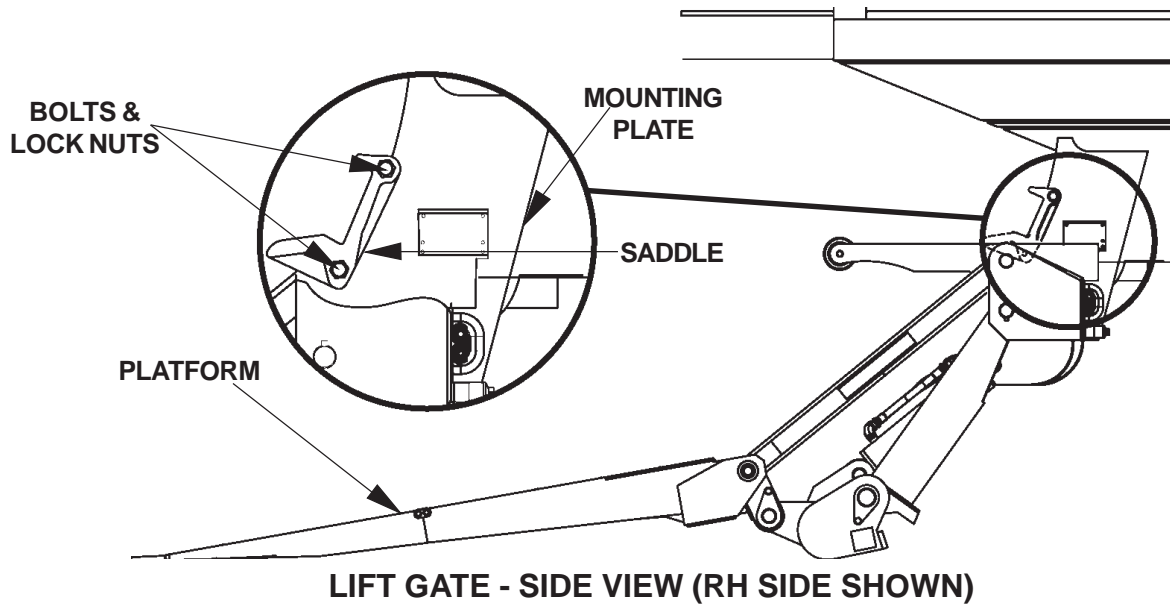

3. Stow the Platform as shown in **FIG. 3A**. Use floor jack positioned at center of Platform (near hinge) to raise Platform 1/8" above Roller (**FIG. 3B**). Reinstall Saddle, Bolts and Locknuts on RH side Mounting Plate (**FIG. 3A**). Repeat for Saddle on LH side. Butt each Saddle against Platform, and tighten lock nuts.

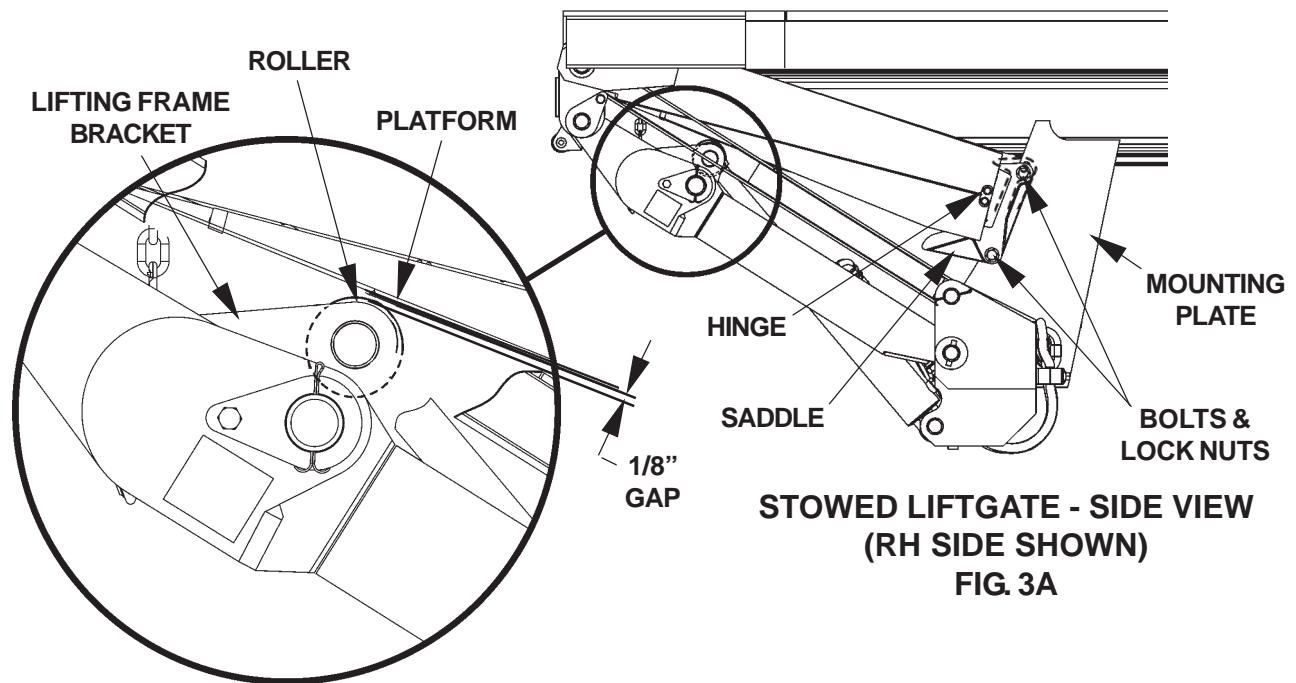

GAP BETWEEN PLATFORM & ROLLER FIG. 3B

MAXON[®]

11921 Slauson Ave. Santa Fe Springs, CA. 90670 (800) 227-4116 FAX (888) 771-7713

REPLACING PLATFORM TORSION SPRING

1. Manually fold Flipover onto Platform.
2. Raise Platform to a convenient work height to gain access and release tension on the Torsion Spring.

CAUTION
To prevent injury and equipment damage, make sure there is no tension on torsion spring before removing hinge pin.

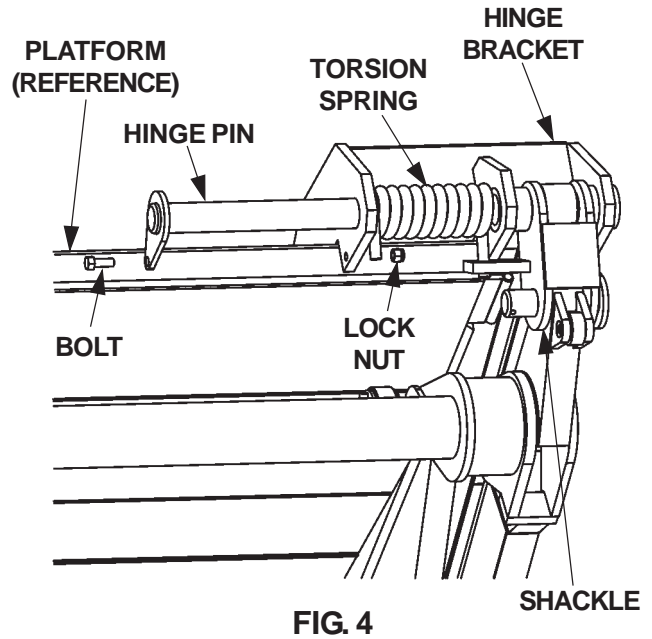

3. Unbolt Hinge Pin from Hinge Bracket (**FIG. 4**). Remove bolt and lock nut. Drive the Hinge Pin inboard toward the Shackle with a hammer and pin punch, just enough to free the torsion spring (**FIG. 4**). Remove spring from Shackle.
4. Install the Torsion Spring as shown in **FIG. 5**. Make sure the long leg of the spring is inserted in the bracket located on Shackle (**FIG. 5**). Make sure the short end of the spring is visible and resting against the edge of the Hinge Bracket (**FIG. 5**).

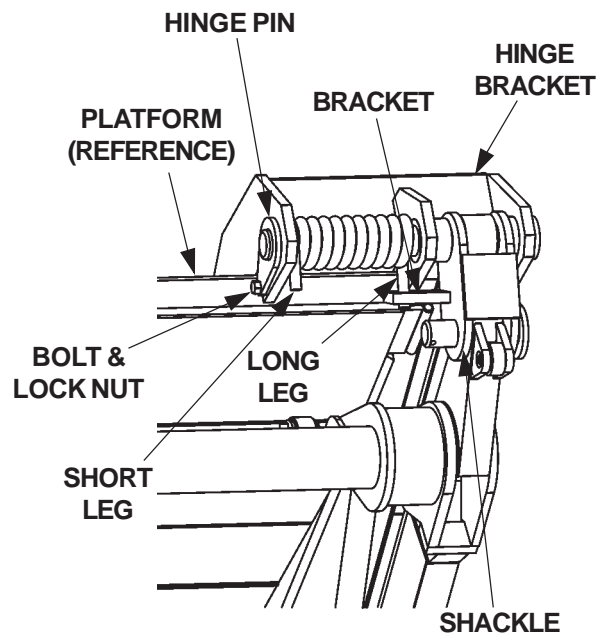

5. Drive the Hinge Pin into correct position (**FIG. 5**) through the Hinge Bracket with a hammer and pin punch. Line up the bolt hole in the Hinge Pin with the hole in the Hinge Bracket. Bolt the Hinge Pin to Hinge Bracket with bolt and lock nut (**FIG. 5**).

6. Operate the Liftgate to make sure it operates correctly.

FIG. 5

PLATFORM ADJUSTMENT

NOTE: Before doing the following procedure, make sure vehicle is parked on level ground.

1. Make sure Platform is at ground level. Unfold the Platform and Flipover. The Shackles and the outboard edge of Platform must touch the ground at the same time as shown in **FIG. 7**. If the Shackles and the outboard edge of Platform are touching the ground, **RAISE** Platform to bed height. Outboard edge of Platform should be above bed level (**FIG. 6**). If indications are correct (**FIGS. 6 & 7**), Liftgate is installed correctly and no adjustment is needed. If indications are incorrect, continue with instruction 2.

2. If the platform is level at bed level (**FIG. 8**), if Shackles do not touch the ground (**FIG. 9**), or if edge of Platform does not touch the ground (**FIG. 10**), inspect each of the Hinge Pins for visible wear before adjusting the Platform. Replace Hinge Pins that are visibly worn. Refer to Parts Breakdown section of this manual for repair parts.

3. Check Liftgate for structural damage that may cause incorrect platform positioning. Repair structural damage.

NOTE: If the Platform is like **FIG. 7** and there is no structural damage or damaged hinge pins, do instruction 4. If the Shackle touches and the Platform edge does not (**FIG. 9**), skip 4 and do 5.

4. Make sure Platform is still at ground level. If the Shackle is not touching the ground, measure and compare distance "A" (**FIG. 9**) with **TABLE 1** to determine the correct shim. Make shims as needed (**FIG. 11**). Weld shim as shown in **FIG. 12**.

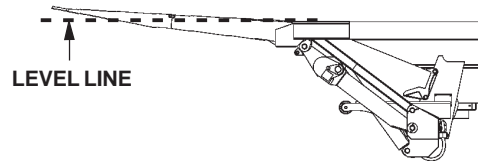

**PLATFORM EDGE ABOVE BED LEVEL
FIG. 6**

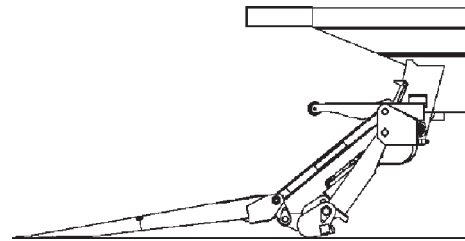

**PLATFORM & SHACKLES
TOUCH GROUND
FIG. 7**

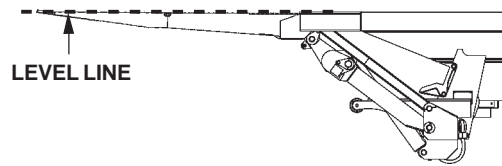

**PLATFORM EDGE AT BED LEVEL
FIG. 8**

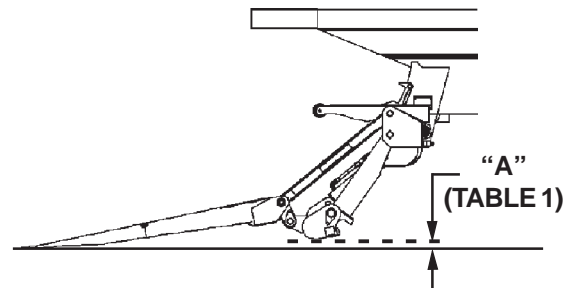

**SHACKLES DO NOT TOUCH GROUND
FIG. 9**

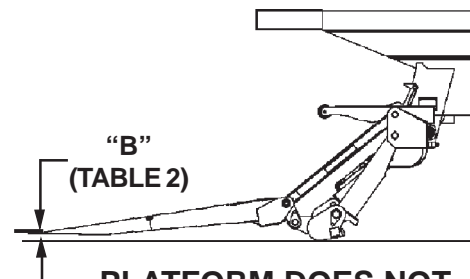

**PLATFORM DOES NOT
TOUCH GROUND
FIG. 10**

5. Make sure Platform is still at ground level. If edge of the Platform is not touching the round, measure and compare distance "B" (FIG. 10) with TABLE 2 to determine how much to grind from the Platform Stops (FIG. 13). Grind correct amount of metal (TABLE 2) from Platform Stop as shown in FIG. 13 .

RAISE PLATFORM EDGE (OUTBOARD) THIS DISTANCE ("A")	REQUIRED SHIM THICKNESS	WELD SIZE "W"
1"	1/16"	1/16"
2"	1/8"	1/8"
3"	3/16"	3/16"
4"	1/4"	1/4"

TABLE 1

LOWER PLATFORM EDGE (OUTBOARD) THIS DISTANCE("B")	GRIND METAL FROM PLATFORM STOP
1"	1/16"
2"	1/8"
3"	3/16"
4"	1/4"

TABLE 2

6. RAISE the Platform, then LOWER it to the ground. Platform and Shackle should touch the ground at the same time as shown in FIG. 7.

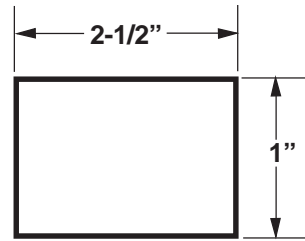

SHIM (1/16", 1/8", or 1/4") MADE FROM STEEL FLAT
FIG. 11

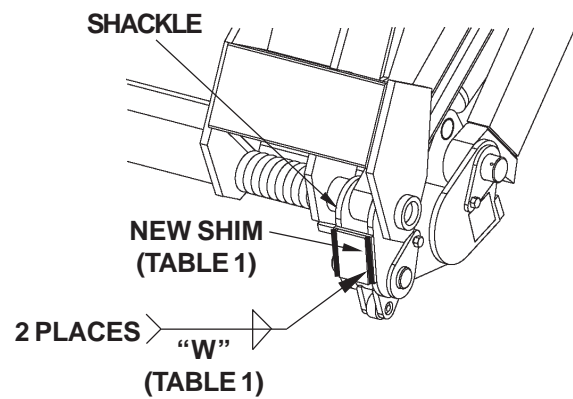

WELDING SHIMS (CURBSIDE SHOWN)
FIG. 12

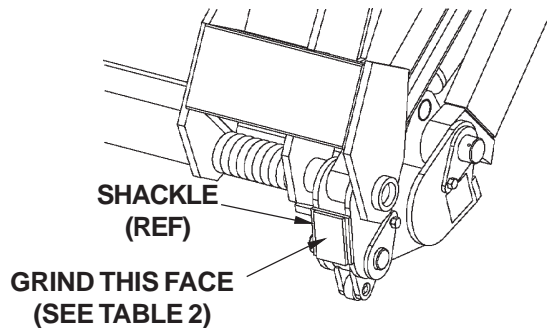

GRINDING PLATFORM STOPS (CURBSIDE SHOWN)
FIG. 13

MAXON®

11921 Slauson Ave. Santa Fe Springs, CA. 90670 (800) 227-4116 FAX (888) 771-7713

PARTS BREAKDOWN

GPT ASSEMBLY

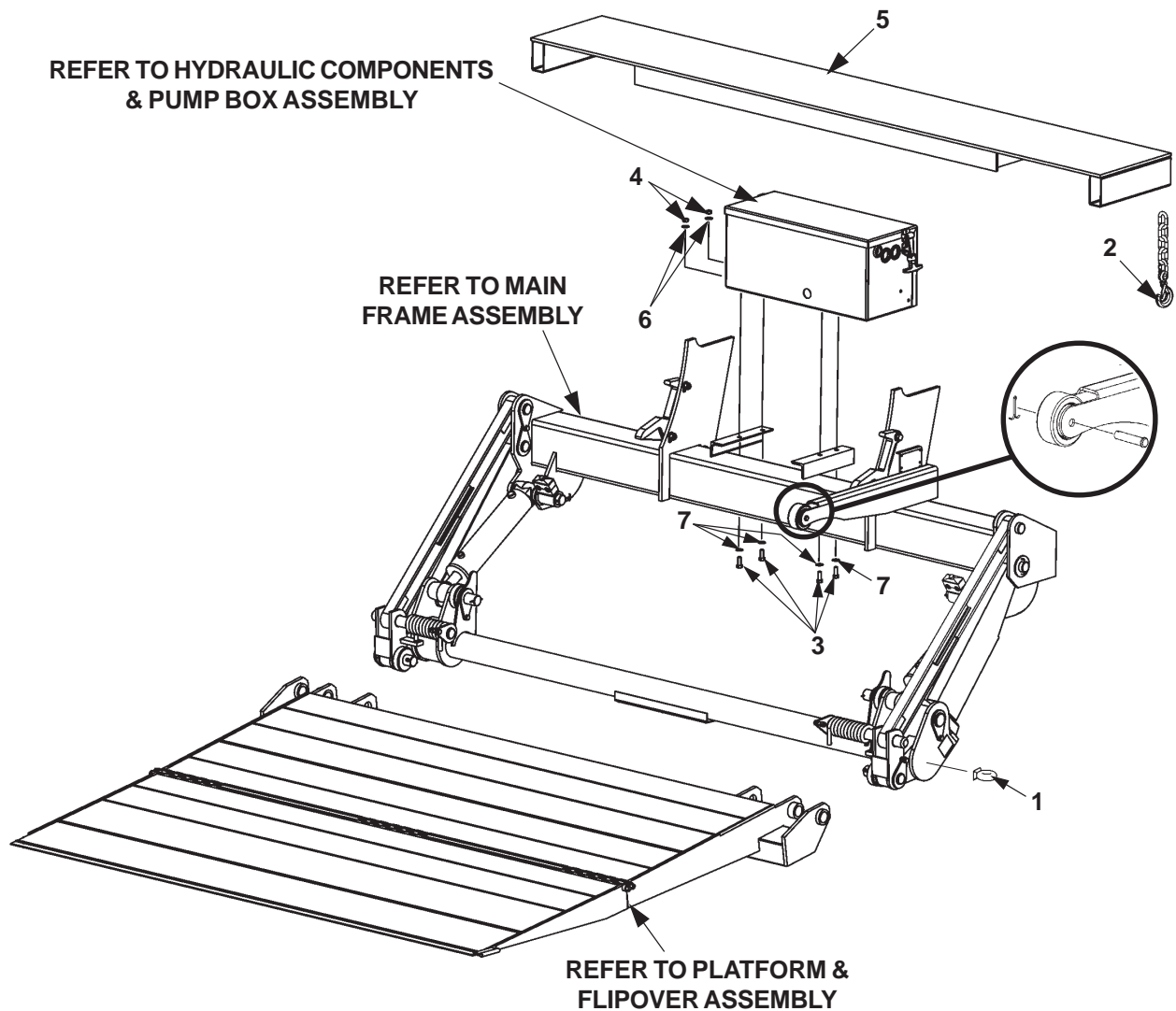

ITEM	QTY.	PART NO.	DESCRIPTION
1	1	226938	EYE, DROP FORGED PAD 3/4" X 1-1/2"
2	1	227700	HOOK ASSEMBLY
3	4	900014-4	BOLT, HEX HEAD 3/8-16 X 1"
4	2	901011-5	NUT, HEX HEAD 3/8-16 UNC-2B
5	1	226355	EXTENSION PLATE
6	2	902001-2	WASHER, FLAT 3/8" X 1/16"
7	4	902011-4	WASHER, LOCK 3/8" X 15/16"
8	1	265994-01	OPENER ASSEMBLY
8A	1	030805	COTTER PIN 1/8" X 1"
8B	1	280082-01	ROLLER
8C	1	905202-03	PIN

MAXON® 11921 Slauson Ave. Santa Fe Springs, CA. 90670 (800) 227-4116 FAX (888) 771-7713

GPT-25/-3 MAIN FRAME ASSEMBLY

MAXON®

11921 Slauson Ave. Santa Fe Springs, CA. 90670 (800) 227-4116 FAX (888) 771-7713

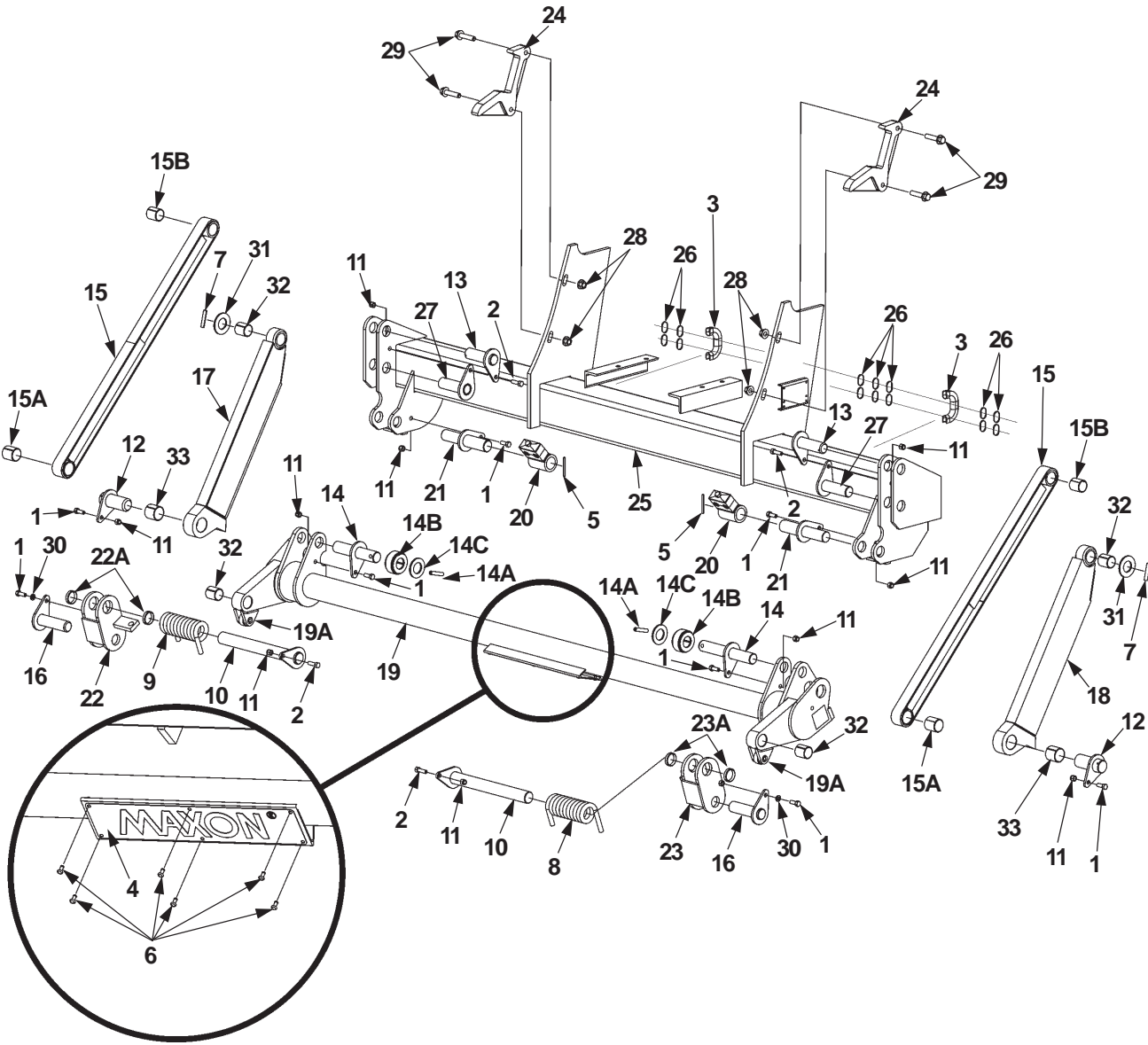

GPT-25/-3 MAIN FRAME ASSEMBLY

ITEM	QTY.	PART NO.	DESCRIPTION
1	8	30034	BOLT, 3/8-24 X 1"
2	4	30035	BOLT 3/8-24 X 1-1/4"
3	2	040103-5	LOOM, SPLIT 1/2" X 5" LG
4	1	50175	PLATE, MAXON HORIZONTAL
5	2	907026	PIN, ROLL 3/16" DIA. X 2-1/4" LG
6	6	207644	RIVET, POP 3/16" X 13/32"
7	2	221416	PIN, ROLL 3/8" X 2"
8	1	226363-01	SPRING, TORSION 1/2" X 5-3/4" RH
9	1	226363-02	SPRING, TORSION 1/2" X 5-3/4" LH
10	2	226364	SUPPORT PIN WELDMENT
11	10	226941	NUT, NYLON LOCK 3/8-24 THIN
12	2	229657	PIN WELDMENT
13	2	250310	PIN WELDMENT
14	2	253085-01	ROLLER PIN, ASSEMBLY
14A	1	221416	PIN, ROLL 3/8" X 2"
14B	1	261793-01	ROLLER
14C	1	264272	FLAT, WASHER 2-1/4"
15	2	261788-01	PARALLEL ARM ASSEMBLY
15A	2	905112-05	BEARING, SELF LUBE 1-3/8" X 1-5/8"
15B	2	905114-04	BEARING, SELF LUBE 1-1/4" X 1-1/2"
16	2	262280	PIN, WELDMENT LIFT FRAME/SHACKLE
17	1	262322-01	LIFT, ARM WELDMENT L/H
18	1	262322-02	LIFT, ARM WELDMENT R/H
19	1	262396	LIFT FRAME WELDMENT ASSEMBLY
19A	2	263473	ROLLER, KNUCKLE DOWN
20	2	262437	BUSHING WELDMENT HOSE CLAMP
21	2	262440	PIN, 1-3/8" X 3-3/8" LG
22	1	265815-01	SHACKLE ASSEMBLY, LEFT HAND
22A	2	905112-06	BEARING SELF LUBE 1-3/8" X 3/8"
23	1	265815-02	SHACKLE ASSEMBLY, RIGHT HAND
23A	2	905112-06	BEARING SELF LUBE 1-3/8" X 3/8"
24	2	265849-01	SADDLE, LOW PROFILE HINGE
25	1	265865-01	MAIN FRAME WELDMENT
26	14	205780	PLASTIC TIE, 7" LG
27	2	266035-01	PIN, WELDMENT UNDERRIDE
28	4	901023	FLANGE LOCK NUT
29	4	901024-3	BOLT, HEX FRAME 2-1/4" LG
30	6	902011-4	WASHER, LOCK 3/8" X 15/16" ZC
31	2	902013-20	WASHER, FLAT 1-1/4" ZC
32	4	905114-04	BEARING, SELF LUBE 1-1/4" X 1-1/2"
33	2	905115-02	BEARING, SELF LUBE 1-1/2" X 1-1/2"

MAXON[®] 11921 Slauson Ave. Santa Fe Springs, CA. 90670 (800) 227-4116 FAX (888) 771-7713

GPT-4/-5 MAIN FRAME ASSEMBLY

MAXON®

11921 Slauson Ave. Santa Fe Springs, CA. 90670 (800) 227-4116 FAX (888) 771-7713

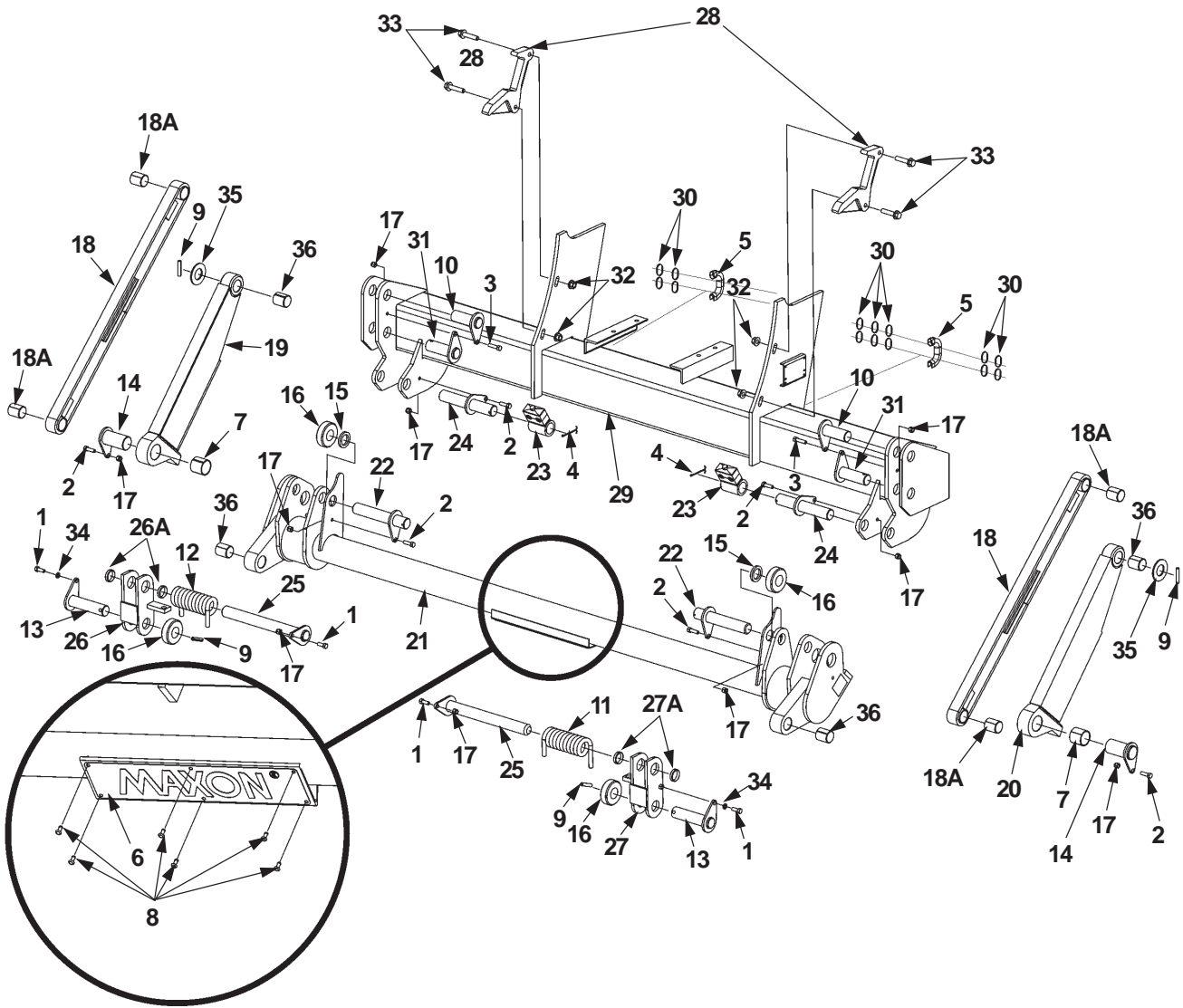

GPT-4/-5 MAIN FRAME ASSEMBLY

ITEM	QTY.	PART NO.	DESCRIPTION
1	4	30034	BOLT, 3/8-24 X 1"
2	6	30035	BOLT 3/8-24 X 1-1/4"
3	2	30038	BOLT, 3/8-24 X 1-1/2"
4	2	30414	PIN, COTTER 1/8" X 2-1/2"
5	2	040103-5	LOOM, SPLIT 1/2" X 5" LG
6	1	50175	PLATE, MAXON HORIZONTAL
7	2	905113-03	BEARING, SELF LUBE 1-3/4" X1-3/4"
8	6	207644	RIVET, POP 3/16" X 13/32"
9	4	221416	PIN, ROLL 3/8" X 2" ZINC
10	2	226358	PIN WELDMENT
11	1	226363-01	SPRING, TORSION 1/2" X 5-3/4" RH
12	1	226363-02	SPRING, TORSION 1/2" X 5-3/4" LH
13	2	226365	PIN, SHACKLE WELDMENT
14	2	226368	LOWER ARM PIN WELDMENT
15	2	226372	ROUND TUBE X 1/4" (2" X 5/16"W)
16	4	226375	ROLLER X 1"
17	10	226941	NUT, NYLON LOCK 3/8-24 THIN
18	2	261785-01	ARM, PARALLEL WELDMENT
18A	4	905112-07	BEARING, SELF LUBE 1-3/8" X 1-3/4"
19	1	262332-01	LIFT ARM WELDMENT R/H
20	1	262332-02	LIFT ARM WELDMENT L/H
21	1	262397	LIFT FRAME WELDMENT ASSEMBLY
22	2	262435	PIN WELDMENT, CYLINDER 1-3/8" DIA.
23	2	262437	BUSHING WELDMENT HOSE CLAMP
24	2	262462	PIN WELDMENT, CYLINDER 1-3/8" DIA.
25	2	265807-01	PIN WELDMENT, PLATFORM
26	1	265813-01	SHACKLE ASSEMBLY, LEFT HAND
26A	2	905112-06	BEARING SELF LUBE 1-3/8" X 3/8"
27	1	265813-02	SHACKLE ASSEMBLY, RIGHT HAND
27A	2	905112-06	BEARING, SELF LUBE 1-3/8" X 3/8"
28	2	265849-01	SADDLE, LOW PROFILE HINGE
29	1	265866-01	MAIN FRAME WELDMENT
30	14	205780	PLASTIC TIE, 7" LG
31	2	266033-01	PIN, WELDMENT UNDERRIDE
32	4	901023	FLANGE LOCK NUT
33	4	901024-3	BOLT, HEX FRAME 2-1/4" LG
34	2	902011-4	WASHER, LOCK 3/8" X 15/16"
35	2	902013-21	WASHER, FLAT 1-3/8"
36	4	905112-07	BEARING, SELF LUBE 1-3/8" X1-3/4"

MAXON[®] 11921 Slauson Ave. Santa Fe Springs, CA. 90670 (800) 227-4116 FAX (888) 771-7713

PLATFORM & FLIPOVER ASSY (NO CART STOP) P/N 265204-01

MAXON®

11921 Slauson Ave. Santa Fe Springs, CA. 90670 (800) 227-4116 FAX (888) 771-7713

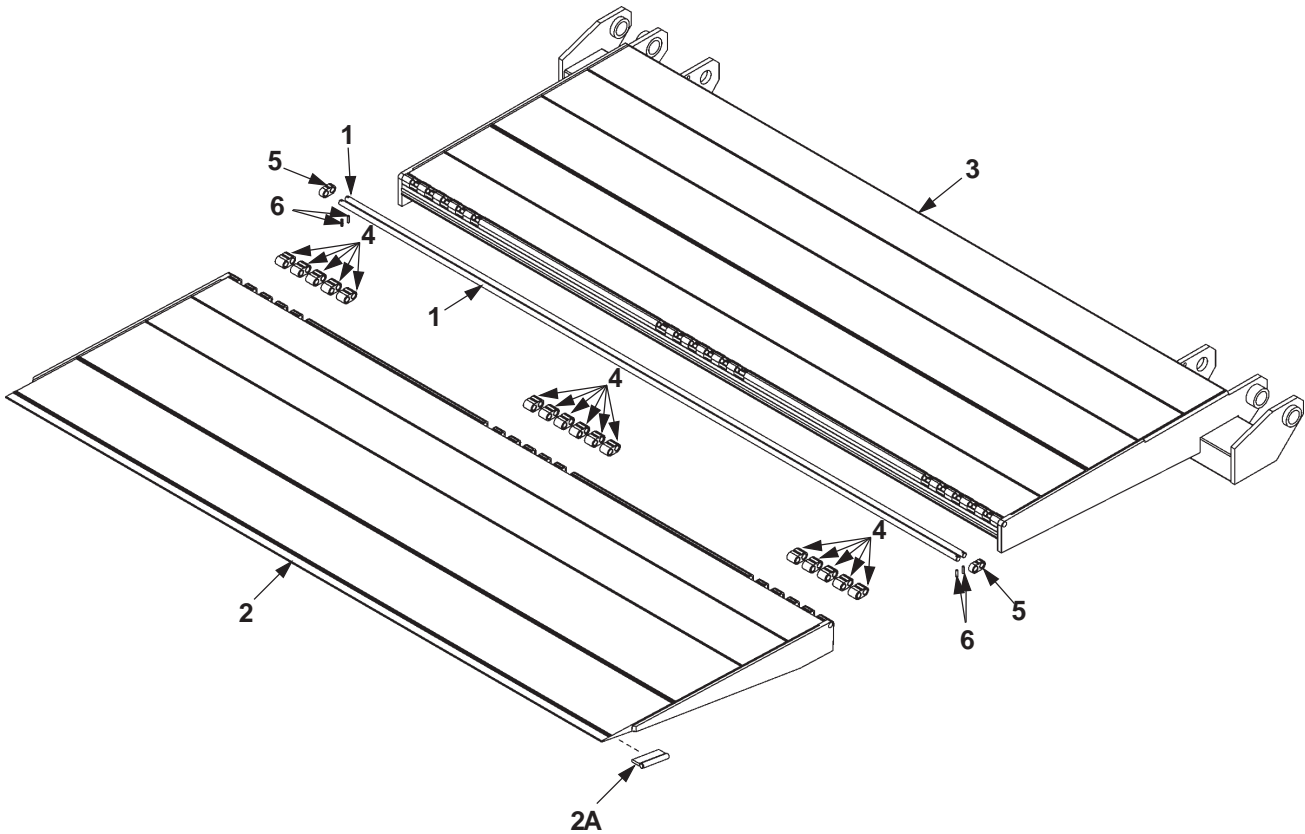

ITEM	QTY.	PART NO.	DESCRIPTION
1	2	263456-04	HINGE ROD 1/2" DIA X 80-13/16" LG
2	1	263665-01	FLIPOVER WELDMENT, ALUMINUM, 30"
2A	1	265819-01	HANDLE WELDMENT
3	1	265203-01	PLATFORM WELDMENT, ALUMINUM, 30"
4	16	280109	HINGE ASSEMBLY
5	2	280110	HINGE ASSEMBLY
6	4	905015-1	ROLL PIN, 3/16" X 3/4"

PLATFORM & FLIPOVER ASSY (SINGLE CART STOP) P/N 265462-01

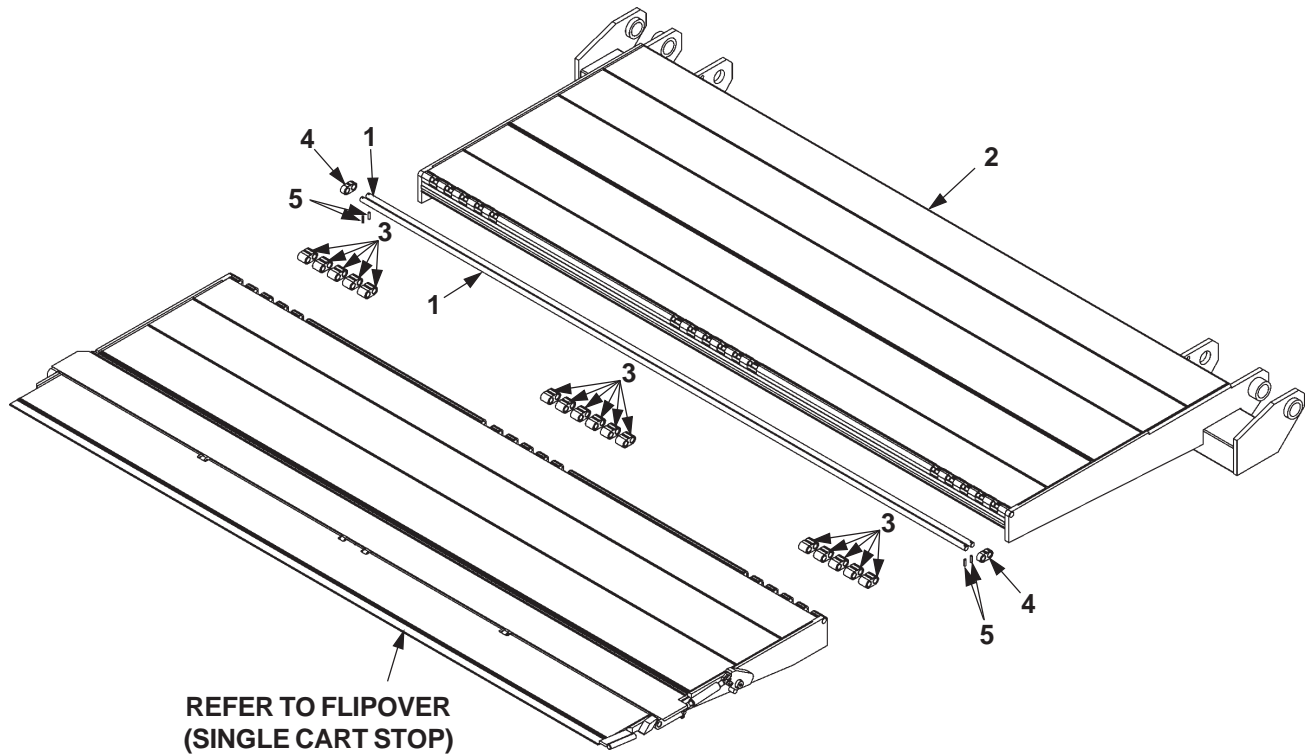

ITEM	QTY.	PART NO.	DESCRIPTION
1	2	263456-04	HINGE ROD 1/2" DIA X 80-13/16" LG
2	1	265203-01	PLATFORM WELDMENT, ALUMINUM, 30"
3	16	280109	HINGE ASSEMBLY
4	2	280110	HINGE ASSEMBLY
5	4	905015-1	ROLL PIN, 3/16" X 3/4"

FLIPOVER (SINGLE CART STOP)

P/N 265457-01

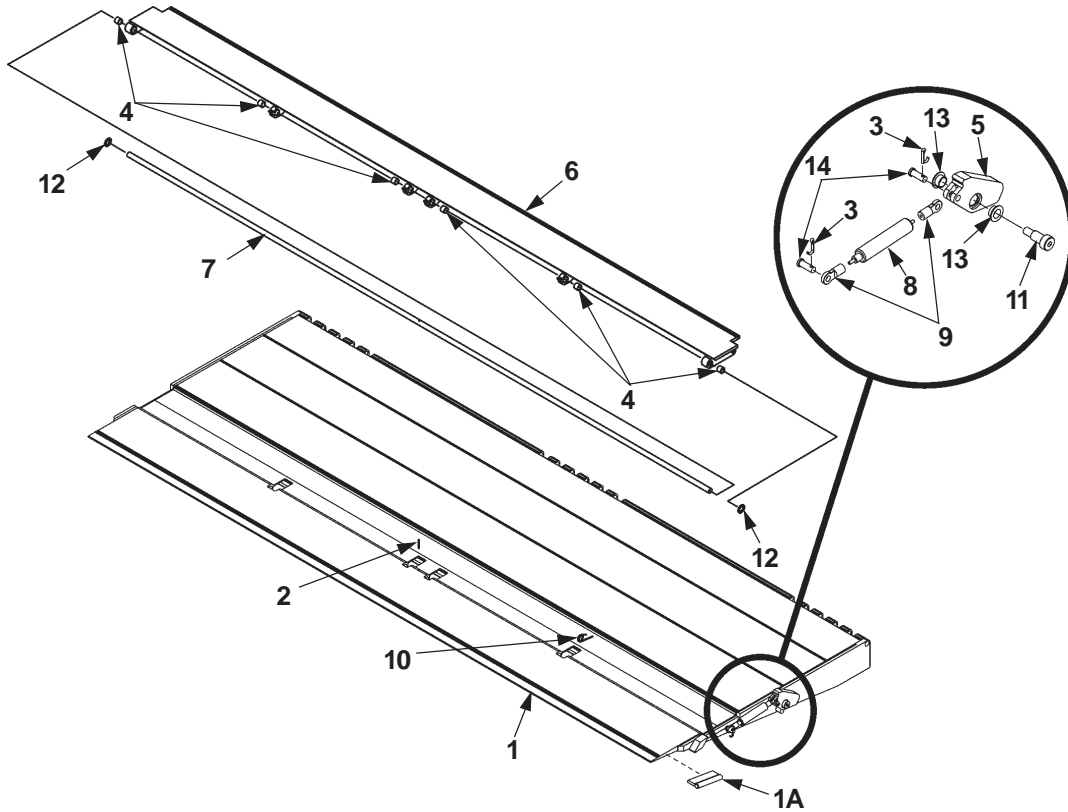

ITEM	QTY.	PART NO.	DESCRIPTION
1	1	263670-01	FLIPOVER WELDMENT, ALUMINUM
1A	1	265819-01	HANDLE WELDMENT
2	1	030406	ROLL PIN, 1/8" X 1"
3	2	030805	COTTER PIN 1/8" X 1"
4	6	253542	BEARING, SELF LUBE 1/2" X 1/2"
5	1	262481-02	ARM, OPENING AND CLOSING, RH
6	1	262508-01	RAMP WELDMENT, SINGLE CART STOP
7	1	262513-01	PIN, 1/2" DIA X 80-39/64" LG
8	1	262514	GAS SPRING
9	2	262515	METAL EYELET END FITING
10	1	262536	SPRING, TORSION, 1/8"
11	1	900047	SCREW, SHOULDER, 1/2" X 3/4" LG
12	2	902022	FLAT WASHER, 1/2"
13	2	905122-02	BEARING, SELF LUBE 1/2" X 5/16"
14	2	905135	PIN, CLEVIS 5/16" X 7/8"

MAXON[®]

11921 Slauson Ave. Santa Fe Springs, CA. 90670 (800) 227-4116 FAX (888) 771-7713

PLATFORM & FLIPOVER ASSY (DUAL CART STOP) P/N 265463-01

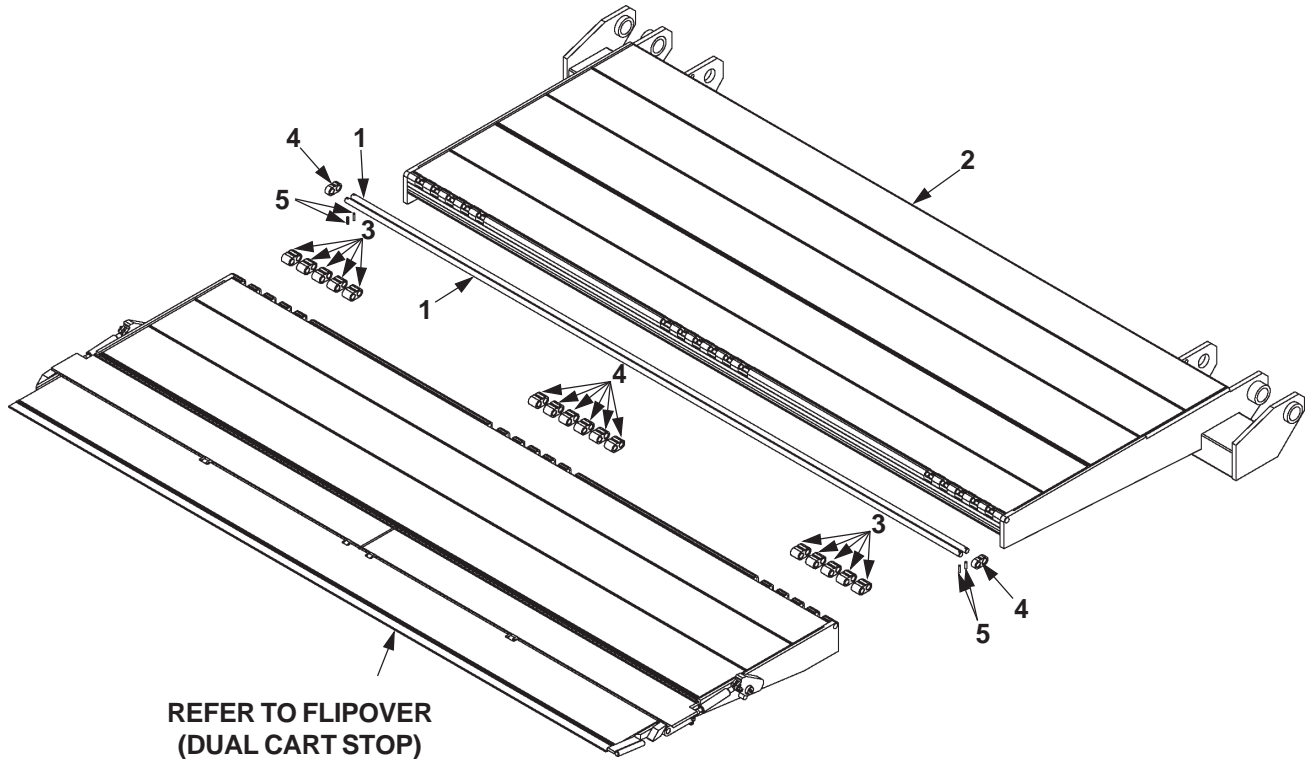

ITEM	QTY.	PART NO.	DESCRIPTION
1	2	263456-04	HINGE ROD, 1/2" DIA X 80-13/16" LG
2	1	265203-01	PLATFORM WELDMENT, ALUMINUM, 30"
3	16	280109	HINGE ASSEMBLY
4	2	280110	HINGE ASSEMBLY
5	4	905015-1	ROLL PIN, 3/16" X 3/4"

FLIPOVER (DUAL CART STOP) P/N 265459-01

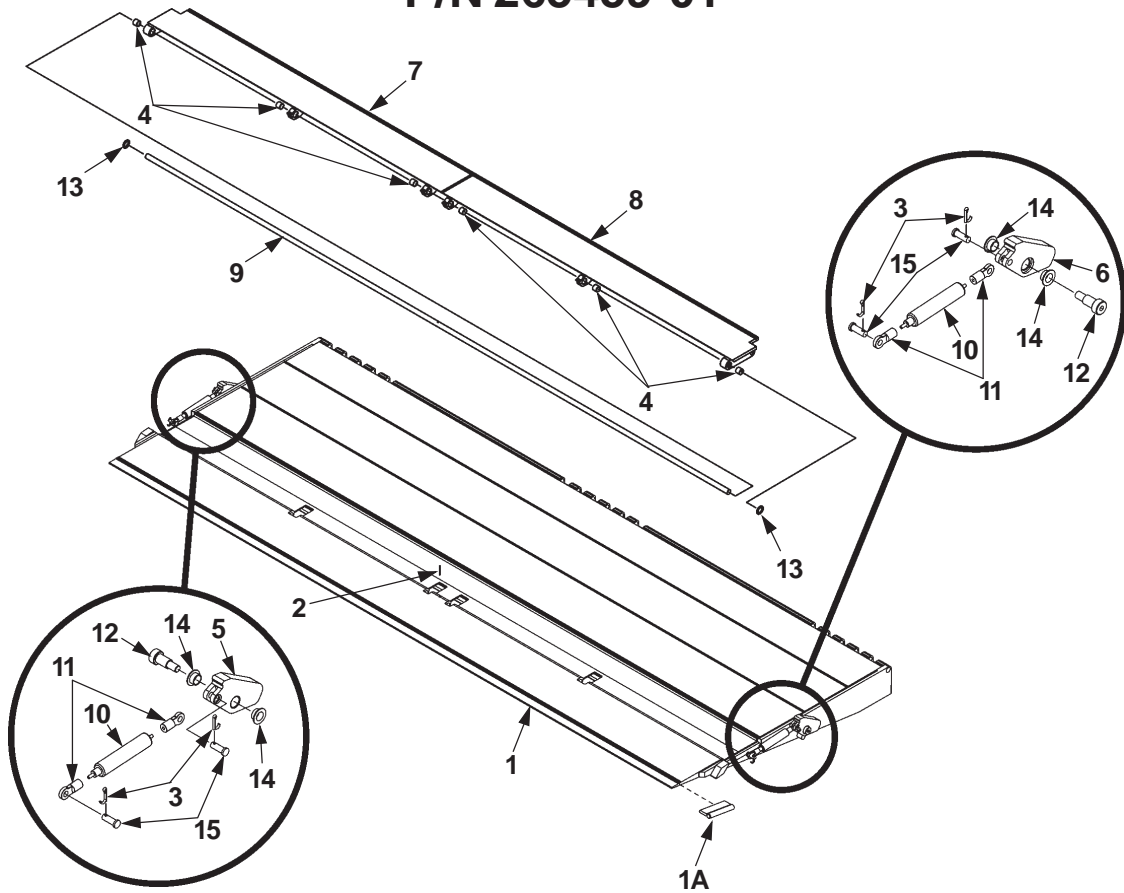

ITEM	QTY.	PART NO.	DESCRIPTION
1	1	263670-02	FLIPOVER ASSEMBLY, ALUMINUM
1A	1	265819-01	HANDLE WELDMENT
2	1	030406	ROLL PIN, 1/8" X 1"
3	4	030805	COTTER PIN 1/8" X 1"
4	6	253542	BEARING, SELF LUBE 1/2" X 1/2"
5	1	262481-01	ARM, OPENING AND CLOSING LH
6	1	262481-02	ARM, OPENING AND CLOSING RH
7	1	262509-03	RAMP WELDMENT, DUAL CART STOP, LH
8	1	262509-04	RAMP WELDMENT, DUAL CART STOP, RH
9	1	262513-01	PIN, 1/2" DIA X 80 39/64" LG
10	2	262514	GAS SPRING
11	4	262515	METAL EYELET END FITING
12	2	900047	SCREW, SHOULDER, 1/2" X 3/4" LG
13	2	902022	FLAT WASHER, 1/2"
14	4	905122-02	BEARING, SELF LUBE 1/2" X 5/16"
15	4	905135	PIN, CLEVIS 5/16" X 7/8"

MAXON[®]

11921 Slauson Ave. Santa Fe Springs, CA. 90670 (800) 227-4116 FAX (888) 771-7713

DOCK BUMPER

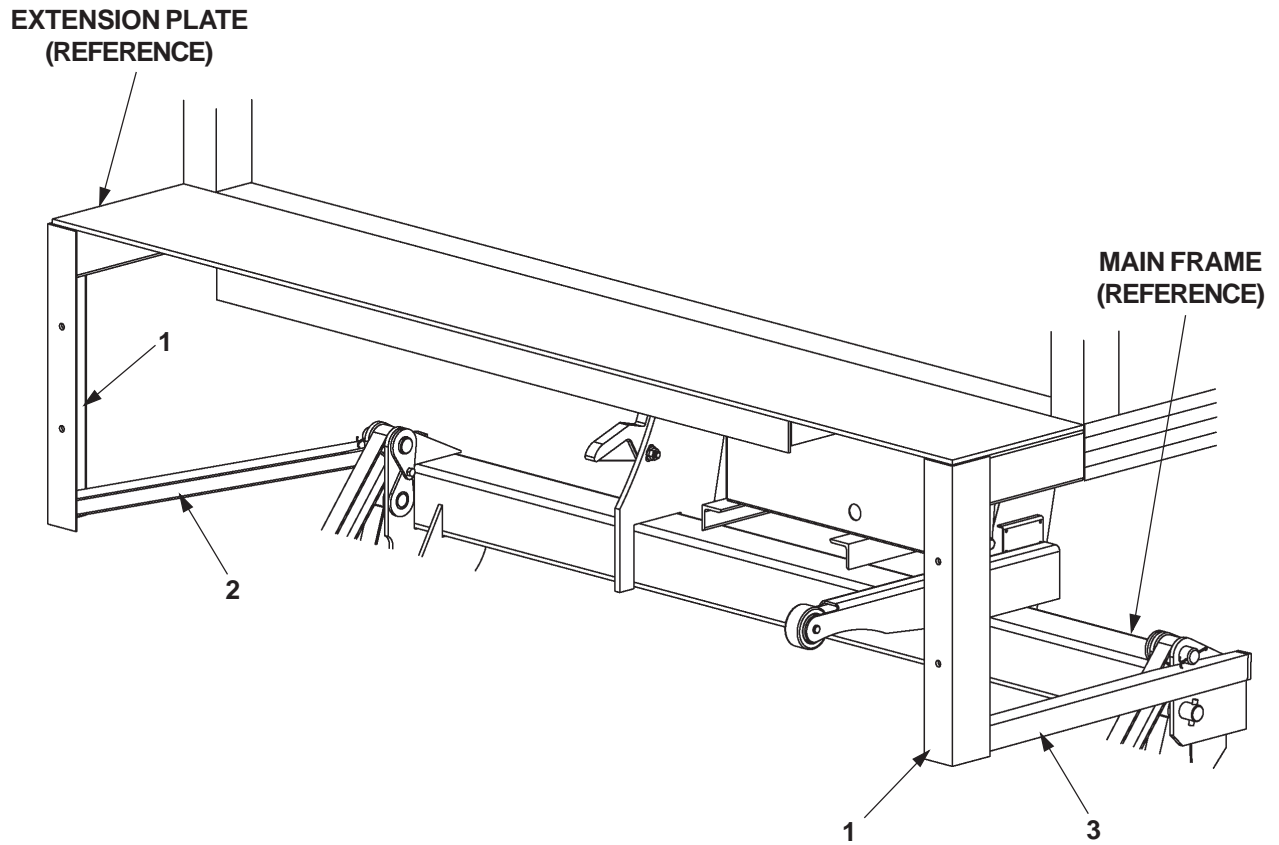

ITEM	QTY.	PART NO.	DESCRIPTION
1	2	226856	DOCK BUMPER ANGLE X 23-1/2"
2	1	266019-01	BRACE ANGLE L/H
3	1	266019-02	BRACE ANGLE R/H

MAXON[®] 11921 Slauson Ave. Santa Fe Springs, CA. 90670 (800) 227-4116 FAX (888) 771-7713

HYDRAULIC COMPONENTS - POWER DOWN

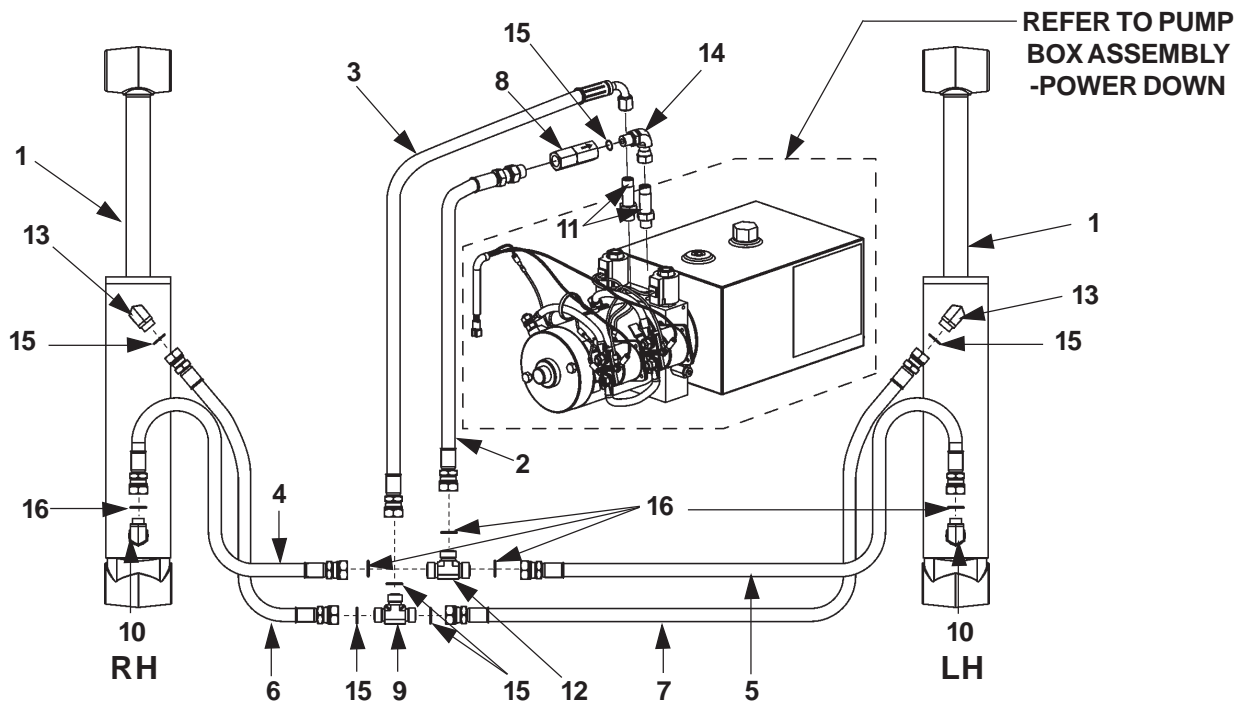

ITEM	QTY.	PART NO.	DESCRIPTION
1	2	266038-01	CYLINDER, 80-3
	2	266039-01	CYLINDER, 80-4
2	1	265846-01	HOSE ASSY, 3/8"HP SAE#8F,#6M, 21" LG.
3	1	265847-01	HOSE ASSY, 3/8"HP SAE#6 F-F, 28" LG.
4	1	265888-01	HOSE ASSY, 3/8"HP SAE#8 F-F, 57" LG.
5	1	265888-02	HOSE ASSY, 3/8"HP SAE#8 F-F, 83" LG.
6	1	265889-01	HOSE ASSY, 3/8"HP SAE#6 F-F, 55" LG.
7	1	265889-02	HOSE ASSY, 3/8"HP SAE#6 F-F, 77" LG.
8	1	906709-01	VALVE, FLOW REGULATOR #6 SAE, 4GPM
9	1	905150	TEE, UNION, 3/8" F/S MALE, 6-JLO
10	2	906704-01	ELBOW, STRAIGHT THR. #8F/S O-RING M-M
11	2	906705-01	CONNECTOR, LONG STR, THD SAE #6
12	1	906706-01	TEE, UNION SAE#8 F/S M-M
13	2	906707-01	ELBOW, STRAIGHT THD. #6F/S O-RING M-M
14	1	906708-01	ELBOW, STRAIGHT THD F/S O-RING #6M-F SW
15	6	906712-02	O-RING #6 (3/8" FACE SEAL TUBE-END)
16	5	906712-03	O-RING #8 (1/2" FACE SEAL TUBE-END)

PUMP BOX ASSEMBLY - POWER DOWN

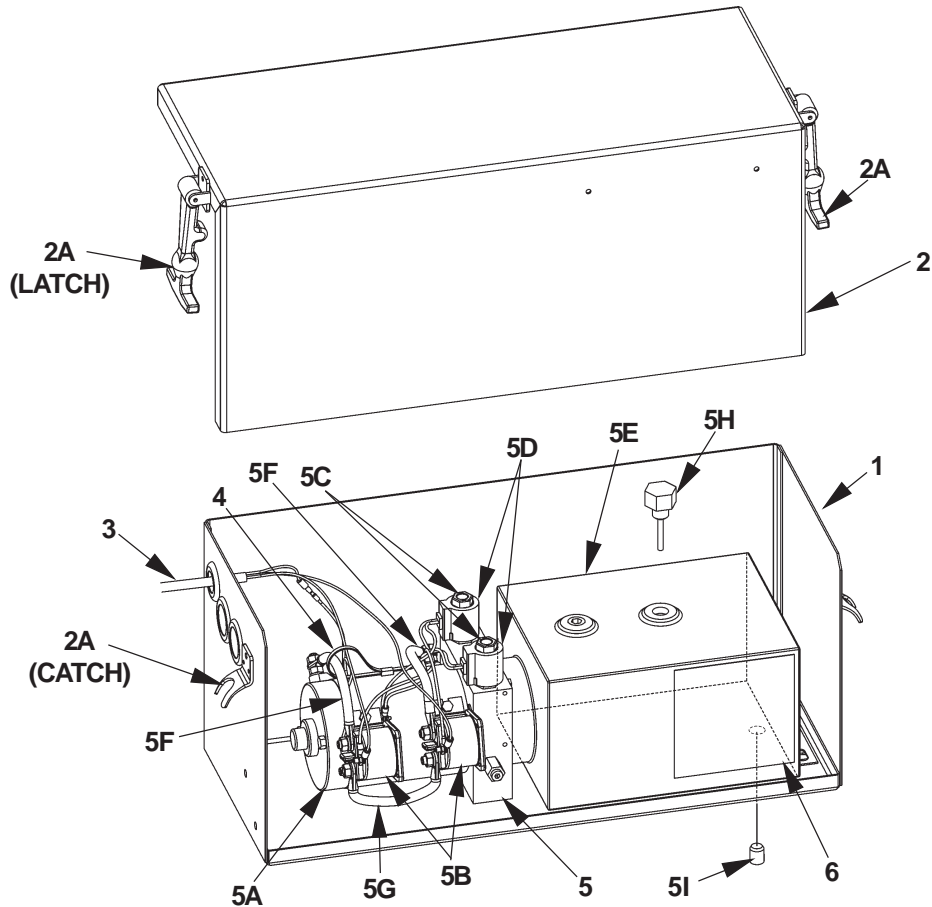

ITEM	QTY.	PART NO.	DESCRIPTION
1	1	266016-01	PUMP BOX WELDMENT
2	1	229383	PUMP BOX COVER
2A	2	215139	CATCH & FASTENER
3	1	266032-01	CABLE ASSEMBLY, 16 GA/3-WIRE
4	1	205780	PLASTIC TIE
5	1	266030-01	PUMP ASSEMBLY, POWER DOWN
5A	1	280381	MOTOR, 12 VOLTS DC
5B	2	280394	MOTOR STARTER SOLENOID, 12 VOLTS DC
5C	2	906719-01	VALVE
5D	2	906720-01	10 VDC COIL
5E	1	906721-01	RESERVOIR
5F	2	280402	CABLE ASSEMBLY (2 GA)
5G	1	280543	CABLE ASSEMBLY (2 GA)
5H	1	229193	FILLER-BREATHER
5I	1	TBD	DRAIN PLUG
6	1	REF	DECAL (SEE DECAL SECTION)

CONTROL SWITCH AND POWER CABLE

MAXON[®]
 11921 Slauson Ave. Santa Fe Springs, CA. 90670 (800) 227-4116 FAX (888) 771-7713

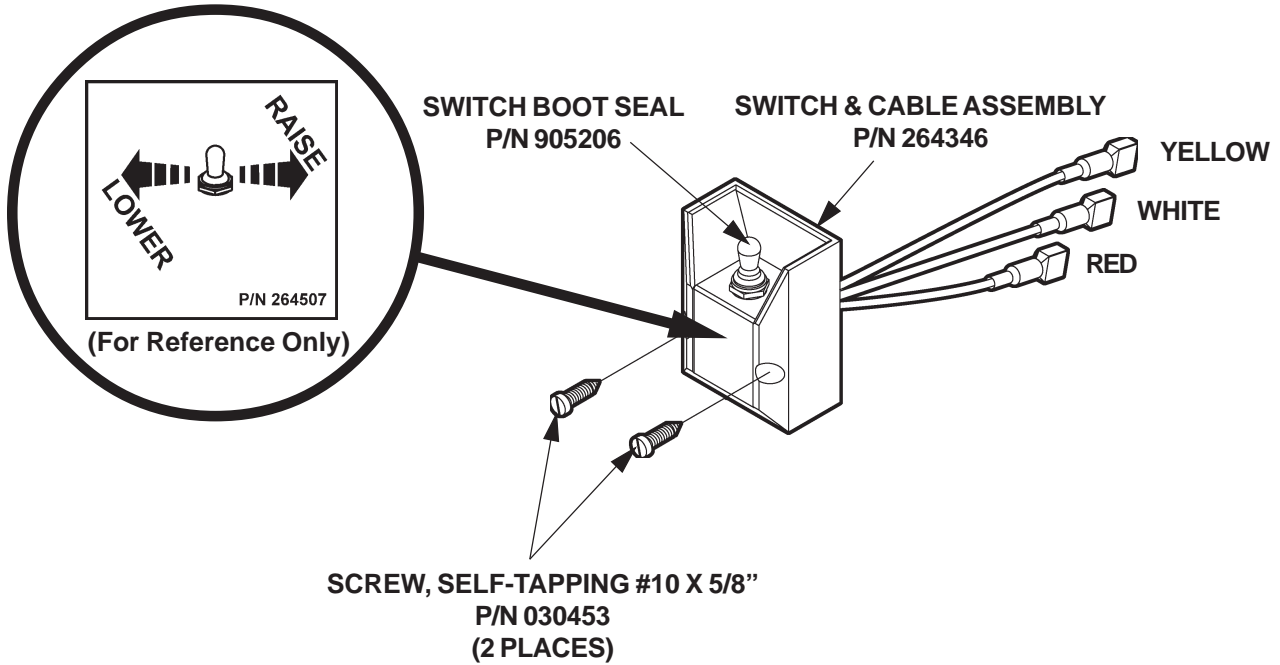

NOTE: Use Switch to **RAISE** and **LOWER** Liftgate to make sure Switch operates as shown on the decal.

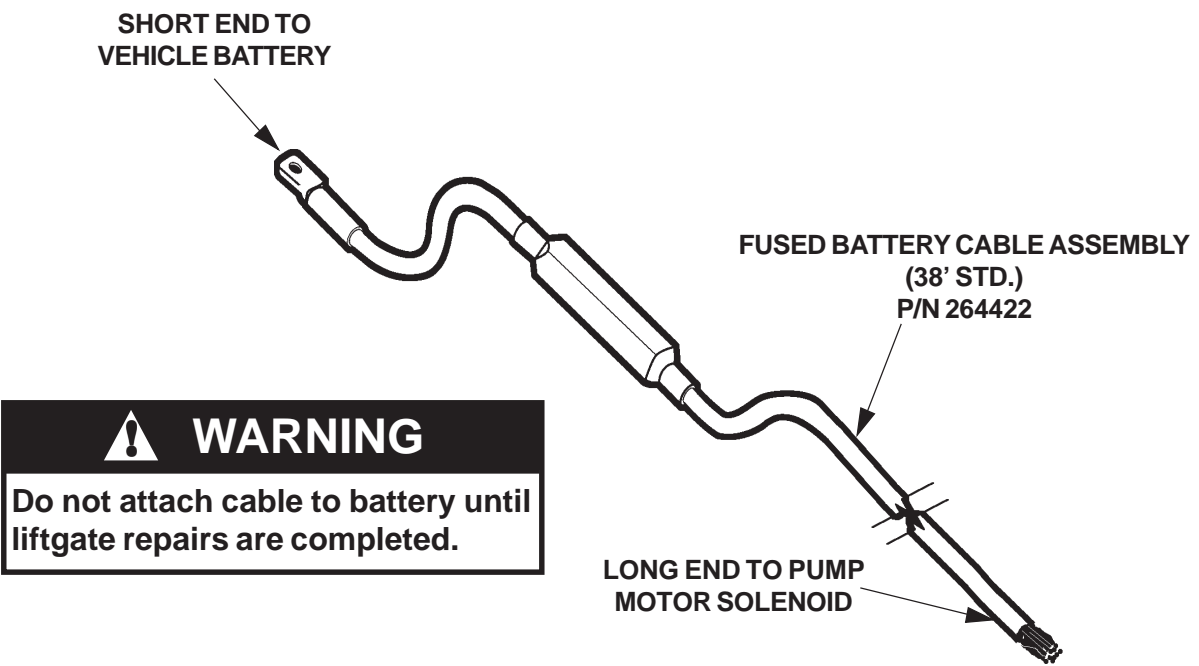

! WARNING
 Do not attach cable to battery until liftgate repairs are completed.

DECALS

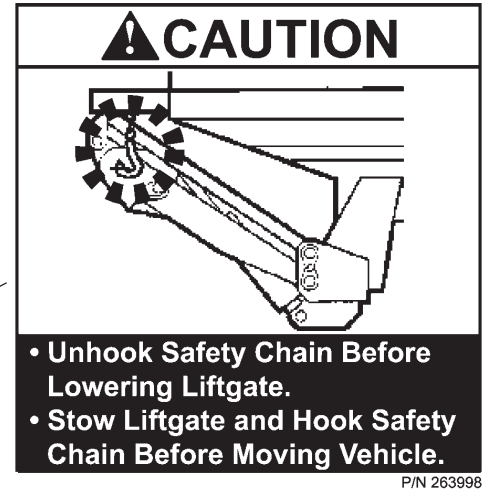
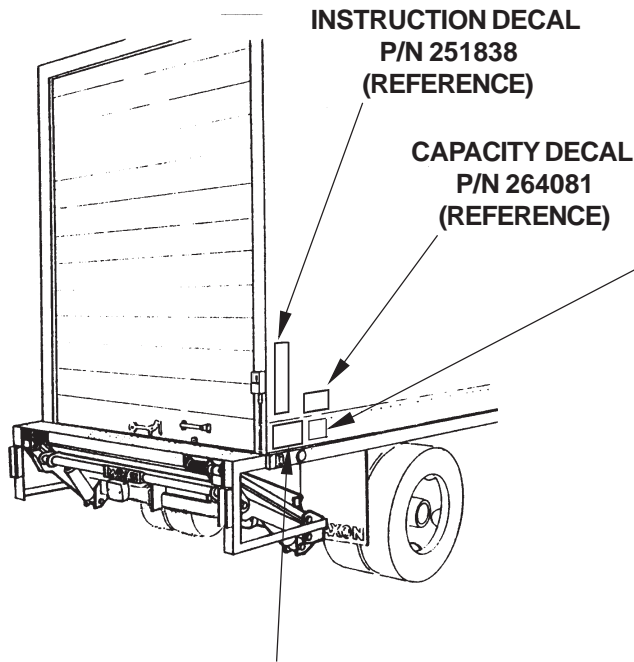

CAUTION DECAL
P/N 263998

WARNING

READ THIS INFORMATION CAREFULLY

- Improper operation of this Lift can result in serious personal injury. Do not operate unless you have been properly instructed and have read, and are familiar with the operating instructions. If you do not have a copy of the instructions, please obtain them from your employer, distributor, or lessor, before you attempt to operate Lift.
- Be certain that the vehicle is properly and securely braked before using the Lift.
- Always inspect this Lift for maintenance or damage before using it. If there are signs of improper maintenance, damage to vital parts, or slippery Platform surface, do not use the Lift until these problems have been corrected.
- Do not overload the Lift. The load limit is based on evenly distributed cargo over the entire Platform surface. If you are using a pallet jack, be sure it can be maneuvered safely. Do not operate a forklift on the Platform or travel with the platform in an open position at any time.
- Load should be placed in a stable position close to the edge of the Platform nearest the truck. The heaviest portion of the load should never be placed beyond the center of the Platform away from the truck.
- Never allow yourself, a helper, or bystander to stand in a position where a falling load could land on either of you. Also do not allow any part of yours or your helper's body to be placed under, within, or around any portion of the moving liftgate, or its mechanisms, or in a position that would trap them between the platform and the ground or truck when the liftgate is operated.
- If a helper is riding the Platform with you, make sure you are both doing so safely and that you are not in danger of coming in contact with any moving or potentially moving obstacles. USE GOOD COMMON SENSE. If load appears to be unsafe, do not lift or lower it.

For a free copy of other manuals that pertain to this model Liftgate, please visit our website at www.maxonlift.com or call Customer Service at (800) 227- 4116.

MAXON LIFT CORP. PART NO. 264081

WARNING DECAL
P/N 264081

MAXON[®] 11921 Slauson Ave. Santa Fe Springs, CA. 90670 (800) 227-4116 FAX (888) 771-7713

DECALS - Continued

MAXON[®]

11921 Slauson Ave. Santa Fe Springs, CA. 90670 (800) 227-4116 FAX (888) 771-7713

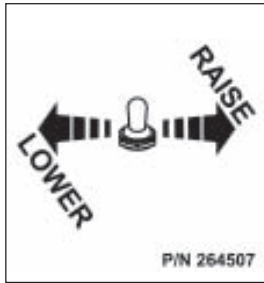

WARNING DECAL
P/N 264081
(REFERENCE)

CAUTION DECAL
P/N 263998
(REFERENCE)

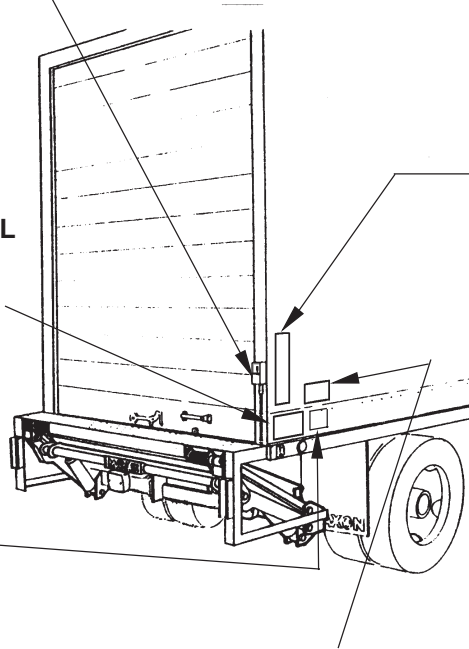

THE MAXIMUM CAPACITY
OF THIS LIFT IS

POUNDS

WHEN THE LOAD IS
CENTERED ON PLATFORM

CAPACITY DECAL (SEE TABLE 1)
P/N 264081

LIFT CAPACITY DECALS	
CAPACITY	PART NO.
2500 LBS.	220382
3000 LBS.	220388
4000 LBS.	220389
5000 LBS.	220390

TABLE 1

OPERATING INSTRUCTIONS

GPT & 80 SERIES LIFTGATES

- 1** UNHOOK SAFETY CHAIN. (SEE CAUTION DECAL.)
- 2** PUSH CONTROL SWITCH

(MUST TOUCH THE GROUND)
- 3** UNFOLD PLATFORM.
- 4** UNFOLD FLIPOVER.
- 5** USE SWITCH TO RAISE / LOWER.
- 6** TO TUCK UNIT AWAY REVERSE STEPS 1, 2, 3, & 4.

DECAL, P/N 251838

INSTRUCTION DECAL
P/N 251838

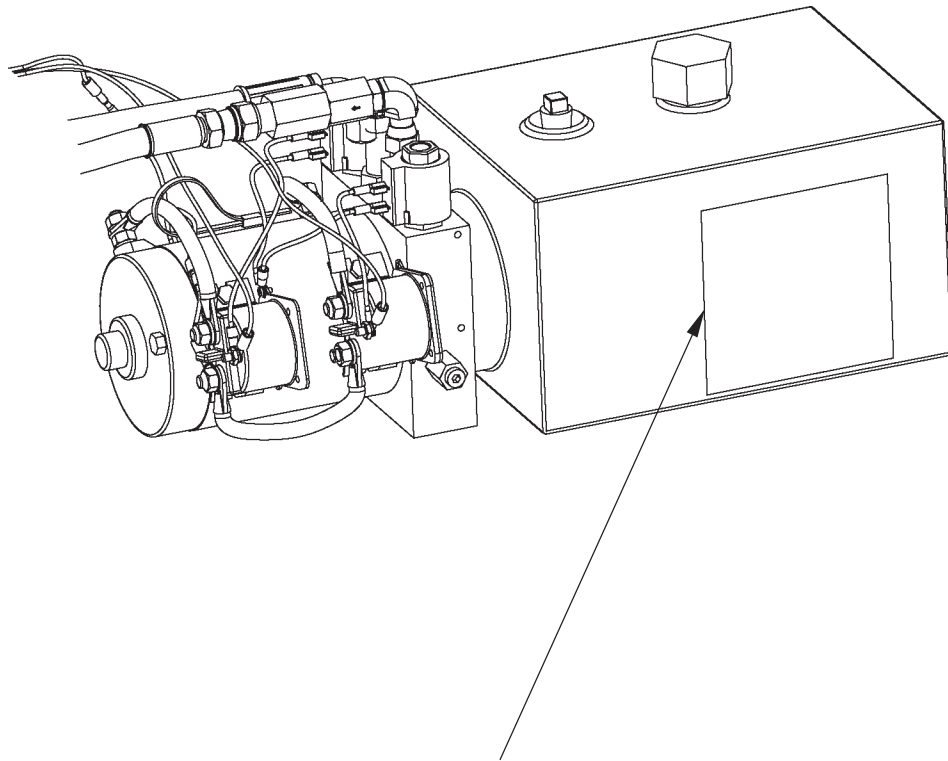

HYDRAULIC FLUID LEVEL

1. Platform must be open and on the ground to check hydraulic fluid level (see illustration). Remove Filler Cap and look in filler hole. Reservoir is full if fluid level is even with top of **FILL LEVEL** bar.

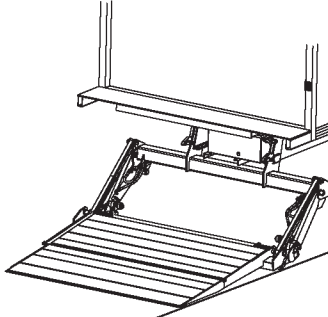



FILL LEVEL



2. If fluid level is lower than top of **FILL LEVEL** bar, add hydraulic fluid (see **SPECS**). Fill until fluid level is even with top of **FILL LEVEL** bar. Re-install Filler Cap.

HYDRAULIC FLUID SPECS.

	+150°F	Use
	+ 20°F	ISO - 32
	+ 20°F	Use
		ISO - 15

P/N 265330-03

FLUID LEVEL DECAL
P/N 265330-03

MAXON[®]

11921 Slauson Ave. Santa Fe Springs, CA. 90670 (800) 227-4116 FAX (888) 771-7713

THIS PAGE INTENTIONALLY LEFT BLANK

SCHEMATICS

HYDRAULIC SCHEMATIC - POWER DOWN

MAXON[®]

11921 Slauson Ave. Santa Fe Springs, CA. 90670 (800) 227-4116 FAX (888) 771-7713

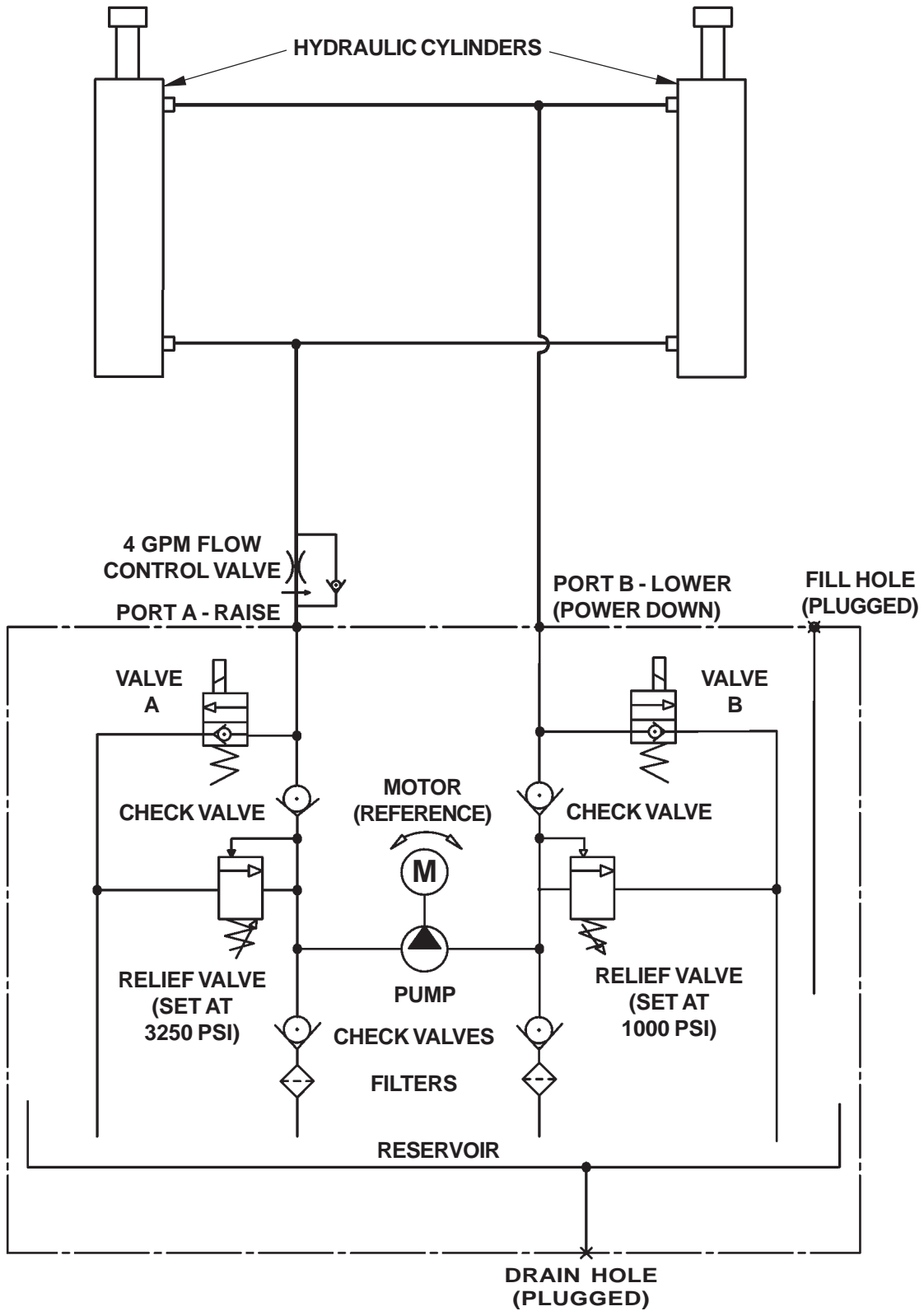

ELECTRICAL SCHEMATIC - POWER DOWN

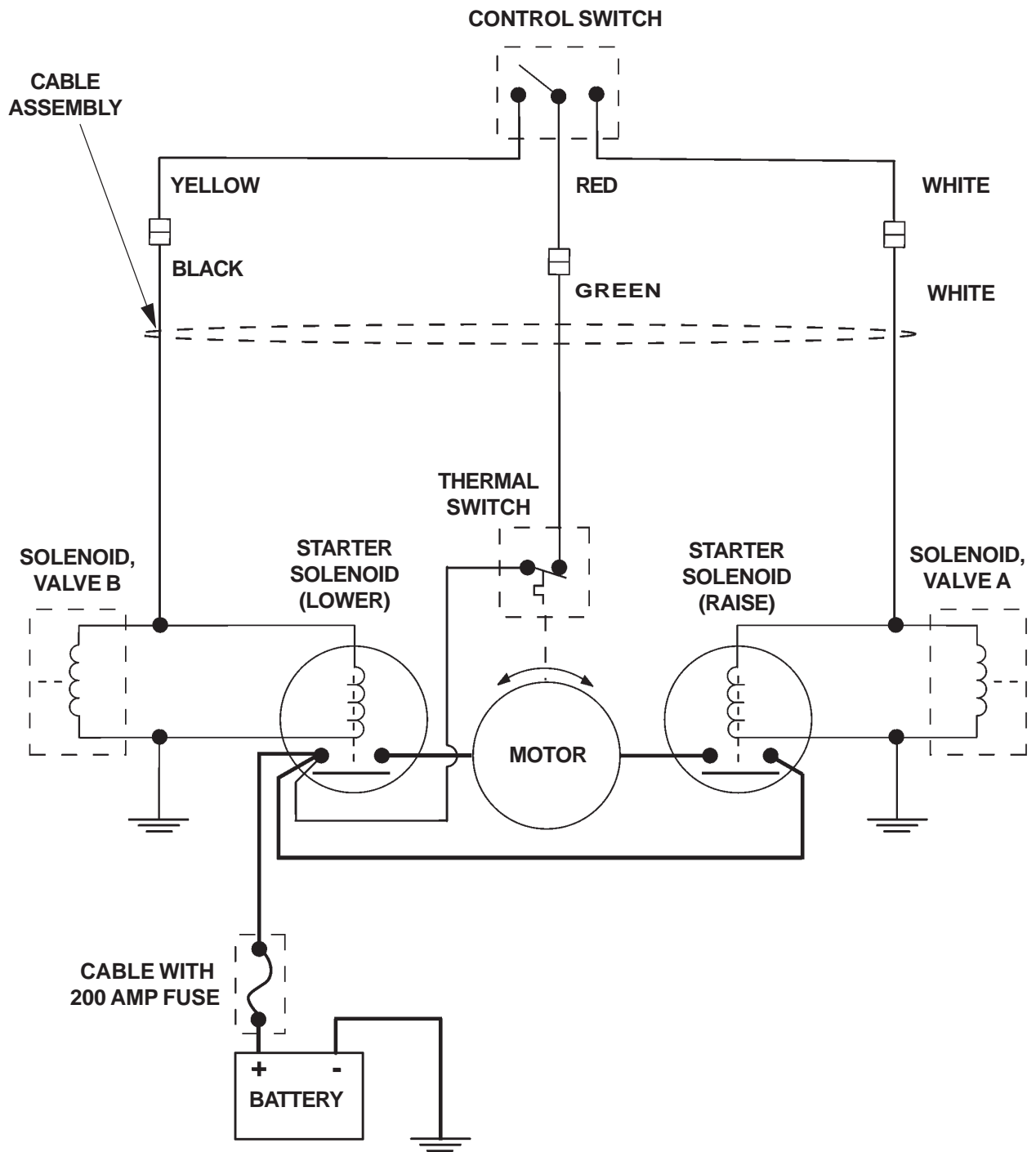

11921 Slauson Ave. Santa Fe Springs, CA. 90670 (800) 227-4116 FAX (888) 771-7713

MAXON

MAXON®

11921 Slauson Ave. Santa Fe Springs, CA. 90670 (800) 227-4116 FAX (888) 771-7713

TROUBLESHOOTING

PLATFORM WILL NOT RAISE

1. Connect voltmeter between Motor Solenoid Terminal “A” and Bracket (**FIG. 1**) to verify that battery power is getting to “A”. Recharge the battery if voltmeter indicates less than 12.6 Volts DC.

CAUTION

Keep dirt, water and other contaminants from entering the hydraulic system. Before opening the hydraulic fluid reservoir filler cap, drain plug and hydraulic lines, clean up contaminants that can get in the openings. Also, protect the openings from accidental contamination during maintenance.

2. Fill Reservoir to within 1/2” below the top with the hydraulic fluid recommended in the Periodic Maintenance Checklist.
3. Touch a jumper wire to terminals “A” & “C” (**FIG. 1**). If motor runs check Switch, switch connections, and White wire. Check and correct wiring connections or replace the Switch.
4. Touch heavy jumper cables to terminals “A” & “B” (**FIG. 1**).
 - a. If motor runs, replace the motor solenoid.
 - b. If motor does not run, repair or replace the pump motor.

NOTE: In most cases, you can avoid having to manually bleed Hydraulic System by correctly positioning Liftgate Platform before disconnecting any Lifting Cylinder high pressure Hydraulic Lines. The following procedure can save time and prevent accidental fluid spills and hazards.

5. Check for structural damage and replace worn parts.
6. Check filter in the pump Reservoir. Replace filter if necessary.
7. Check for dirty pump motor relief valve. Clean if necessary. Replace any worn out relief valve parts.

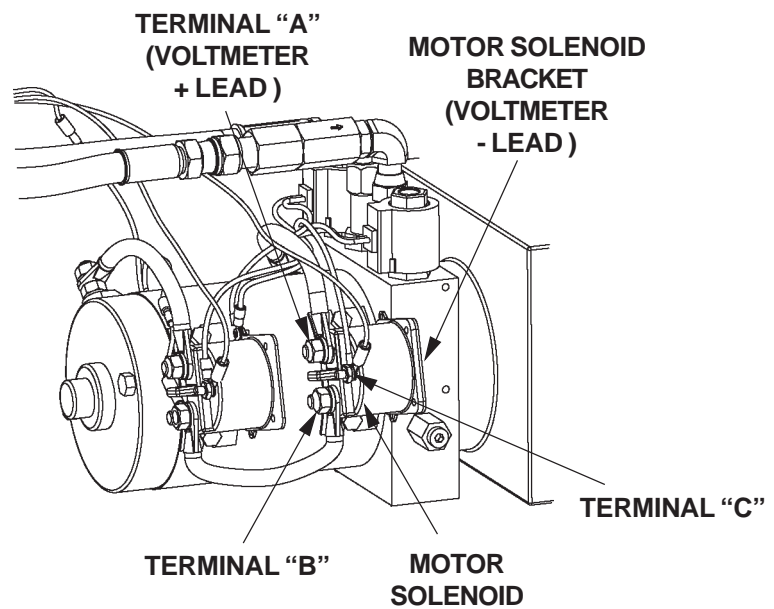
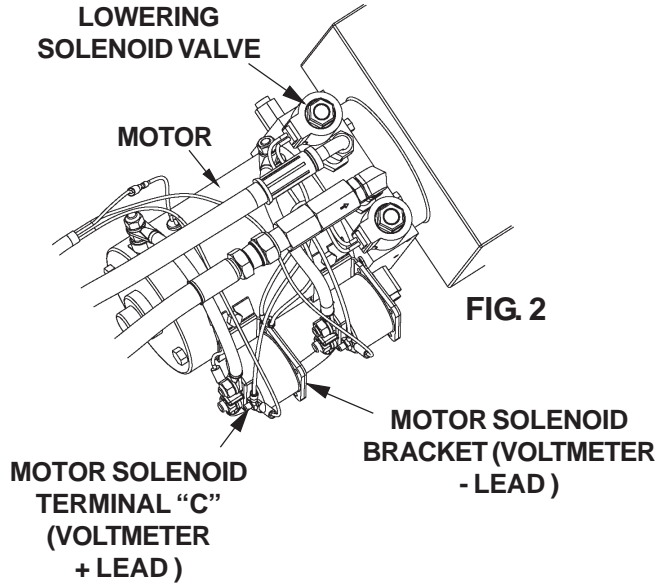

FIG. 1

PLATFORM RAISES BUT LEAKS DOWN

1. Check if Lowering Solenoid Valve is constantly energized. Connect voltmeter negative (-) lead to Motor Solenoid bracket and positive (+) lead to Motor Solenoid terminal "C" (FIG. 2). If voltmeter reads battery voltage (+12.6 Volts DC minimum) without pushing the toggle switch, the control circuit is operating incorrectly. Check if toggle switch, wiring or coil are faulty.



CAUTION

Keep dirt, water and other contaminants from entering the hydraulic system. Before opening the hydraulic fluid reservoir filler cap, drain plug and hydraulic lines, clean up contaminants that can get in the openings. Also, protect the openings from accidental contamination during maintenance.

NOTE: In most cases, you can avoid having to manually bleed Hydraulic System by correctly positioning Liftgate Platform before disconnecting any Lifting Cylinder high pressure Hydraulic Lines. The following procedure can save time and prevent accidental fluid spills and hazards.

2. Check the Valve Stem by removing the Coil Assembly (Item 1, FIG. 3). With platform on ground, unscrew the Valve Stem, (Item 2, FIG. 3) from the Pump. Push on the plunger that is located inside the Valve Stem by inserting a small screwdriver blade in the end. If the Plunger does not move freely (approximately 1/8") replace the Valve Stem. **When re-installing valve stem, torque hex nut to 30 in-lbs.**
3. Check the Hydraulic Cylinder. With the Platform on the ground, remove the hydraulic line from the Down Port of the Cylinder (FIG. 4). Raise the Platform even with the bed. Allow pump motor to run two seconds more while you watch for hydraulic fluid at the Down Port. A few drops of hydraulic fluid escaping the Down Port is normal; however, if it streams from the Down Port, Piston Seals are worn. Replace Seals.

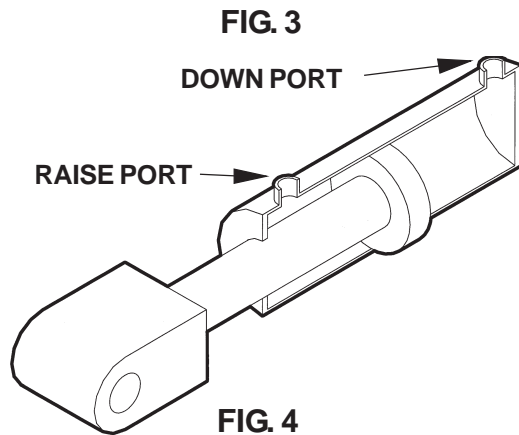
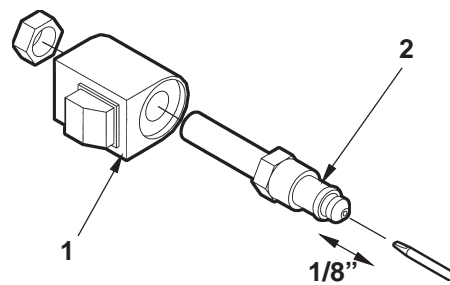

PLATFORM RAISES PARTIALLY AND STOPS

CAUTION

Keep dirt, water and other contaminants from entering the hydraulic system. Before opening the hydraulic fluid reservoir filler cap, drain plug and hydraulic lines, clean up contaminants that can get in the openings. Also, protect the openings from accidental contamination during maintenance.

1. Lower the opened Platform to the ground. Fill the Pump Reservoir on Gravity-Down Liftgates to within 1/2" below the top with hydraulic fluid recommended in Periodic Maintenance Checklist.
2. Use voltmeter to verify that the Battery shows 12.6 volts or more.
3. Check for Structural damage, or poor lubrication. Replace worn parts.

NOTE: In most cases, you can avoid having to bleed the hydraulic system by correctly positioning Liftgate Platform before opening hydraulic lines. Refer to following procedure. Save time on the job and prevent accidental fluid spills and hazards.

4. Check the Hydraulic Cylinder. With the Platform on the ground, remove the Breather Plug or Vent Line from the Vent Port of the Cylinder (**FIG. 5**). Raise the Platform even with the bed. Allow pump motor to run two seconds more while you watch for hydraulic fluid at the Vent Port. A few drops of hydraulic fluid escaping the Vent Port is normal; however, if it streams from the Vent Port, Piston Seals are worn. Replace Seals.
5. Check Filter in the Pump Reservoir. Replace filter if necessary.
6. Check for dirty pump motor relief valve. Clean if necessary. Replace any worn out relief valve parts.

LIFTGATE WILL NOT LIFT RATED CAPACITY

1. Use voltmeter to verify that the Battery shows 12.6 volts or more under load from pump motor.
2. Check for Structural damage or lack of lubrication. Replace worn parts.

CAUTION

Keep dirt, water and other contaminants from entering the hydraulic system. Before opening the hydraulic fluid reservoir filler cap, drain plug and hydraulic lines, clean up contaminants that can get in the openings. Also, protect the openings from accidental contamination during maintenance.

NOTE: In most cases, you can avoid having to bleed the hydraulic system by correctly positioning Liftgate Platform before opening hydraulic lines. Refer to following procedure. Save time on the job and prevent accidental fluid spills and hazards.

3. With Platform on the ground, remove the pressure hose and fitting from the Pump and replace it with a 0-3000 PSI Pressure Gauge. Hold the switch in the "UP" position. Adjust the Relief Valve on the side of the Pump until the gauge shows 2800 to 3000 PSI (**FIG. 6**). Remove guage and re-install pressure hose.
4. Check for dirty pump motor relief valve. Clean if necessary. Replace any worn out relief valve parts.
5. Check the Hydraulic Cylinder. With the Platform on the ground, remove the hydraulic line from the Down Port of the Cylinder (**FIG. 5**). Raise the Platform even with the bed. Allow pump motor to run two seconds more while you watch for hydraulic fluid at the Down Port. A few drops of hydraulic fluid escaping the Down Port is normal; however, if it streams from the Down Port, Piston Seals are worn. Replace Seals.
6. If Pump cannot produce 2800-3000 PSI with a minimum of 12.6 Volts available, the Pump is worn and needs to be replaced.

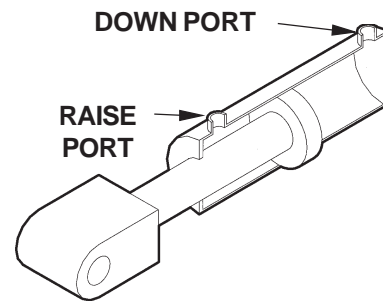

FIG. 5

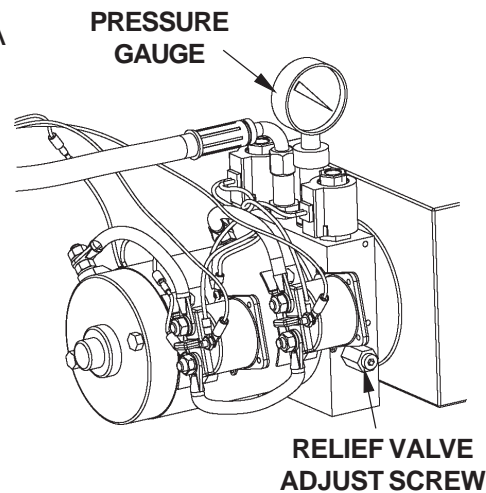

FIG. 6

PLATFORM RAISES SLOWLY

1. Connect voltmeter between Motor Solenoid Terminal "A" and Bracket (**FIG. 7**) to verify that battery power is getting to "A". Recharge the battery if voltmeter indicates less than 12.6 Volts DC.

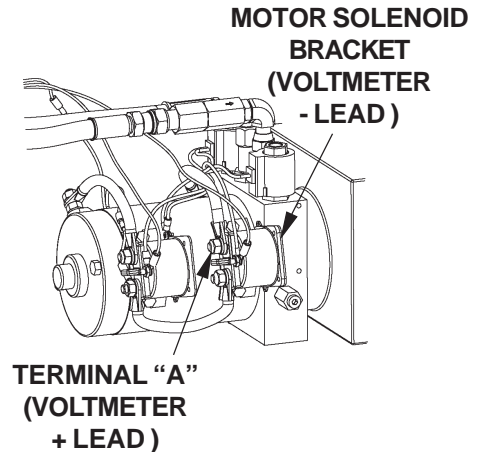

FIG. 7

CAUTION

Keep dirt, water and other contaminants from entering the hydraulic system. Before opening the hydraulic fluid reservoir filler cap, drain plug and hydraulic lines, clean up contaminants that can get in the openings. Also, protect the openings from accidental contamination during maintenance.

2. Check the Hydraulic Cylinder. With the Platform on the ground, remove the hydraulic line from the Down Port of the Cylinder (**FIG. 8**). Raise the Platform even with the bed. Allow pump motor to run two seconds more while you watch for hydraulic fluid at the Down Port. A few drops of hydraulic fluid escaping the Down Port is normal; however, if it streams from the Down Port, Piston Seals are worn. Replace Seals.

NOTE: In most cases, you can avoid having to bleed the hydraulic system by correctly positioning Liftgate Platform before opening hydraulic lines. Refer to following procedure. Save time on the job and prevent accidental fluid spills and hazards.

3. Check and clean Flow Control Valve (**FIG. 8**) in high pressure hydraulic line attached to Cylinder. When installing Flow Control Valve make sure arrow on valve is oriented as shown in **FIG. 8**.
4. Lower the opened Platform to the ground. Fill the Pump Reservoir on Gravity-Down Liftgates to within 1/2" below the top with hydraulic fluid recommended in Periodic Maintenance Checklist.
5. Verify the Pump Motor is grounded to the vehicle frame.
6. Check for leaking hoses and fittings. Tighten or replace as required.
7. Check for structural damage or poor lubrication. Replace worn parts.
8. Check the Filter in the Pump Reservoir. Replace if necessary.

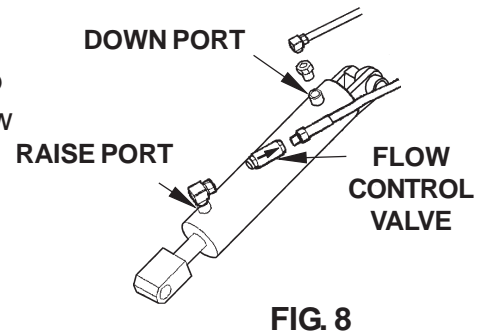

FIG. 8

9. With Platform on the ground, remove the pressure hose and fitting from the Pump and replace it with a 0-3000 PSI Pressure Gauge. Hold the Control switch in the "RAISE" position. Adjust the Relief Valve on the side of the Pump until the gauge shows 2800 to 3000 PSI (**FIG. 9**). Remove gauge and re-install pressure hose.

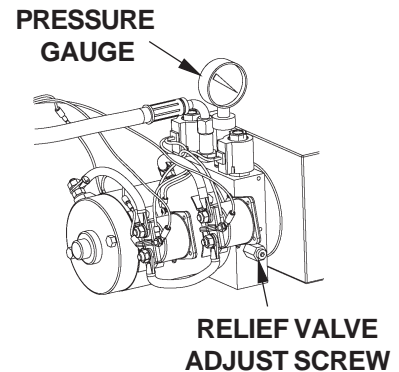

FIG. 9

PLATFORM WILL NOT LOWER, LOWERS TOO SLOWLY, OR LOWERS TOO QUICKLY

MAXON[®]

11921 Slauson Ave. Santa Fe Springs, CA. 90670 (800) 227-4116 FAX (888) 771-7713

1. Connect voltmeter between Motor Solenoid Terminal "A" and Bracket (**FIG. 10**) to verify that battery power is getting to "A". Recharge the battery if voltmeter indicates less than 12.6 Volts DC.
2. Check for structural damage or poor lubrication. Replace worn parts.
3. Check if Lowering Solenoid Valve is getting power. Connect voltmeter between Motor Solenoid Bracket and Motor Solenoid terminal "C" (**FIG. 10**). Push Control Switch to "LOWER" position to energize Lowering Solenoid. If voltmeter reads battery voltage (+12.6 Volts DC minimum), control circuit is operating correctly (replace Lowering Solenoid). If voltmeter reads 0 Volts, check if toggle switch and wiring are faulty.

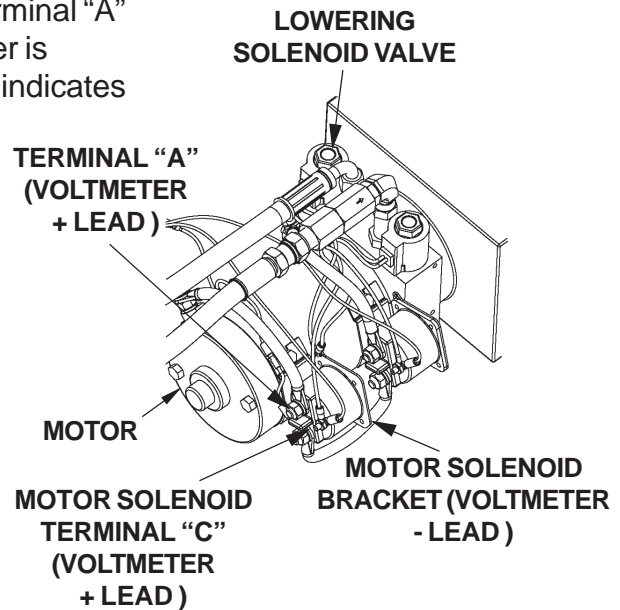

FIG. 10

CAUTION

Keep dirt, water and other contaminants from entering the hydraulic system. Before opening the hydraulic fluid reservoir filler cap, drain plug and hydraulic lines, clean up contaminants that can get in the openings. Also, protect the openings from accidental contamination during maintenance.

NOTE: In most cases, you can avoid having to bleed the hydraulic system by correctly positioning Liftgate Platform before opening hydraulic lines. Refer to following procedure. Save time on the job and prevent accidental fluid spills and hazards.

4. Check the Valve Stem by removing the Coil Assembly (**Item 1, FIG. 11**). With platform supported, unscrew the Valve Stem (**Item 2, FIG. 11**) from the Pump. Push on the plunger located inside the Valve Stem by inserting a small screwdriver blade in the end. If the Plunger does not move freely (approximately 1/8") replace the Valve Stem.
5. Check if filtering screen on solenoid valve is plugged. Clean carefully if required.
6. Check and clean Flow Control Valve in high pressure hydraulic line attached to Cylinder.
7. Check if Flow Control Valve (**FIG. 12**) is pointing to the direction of restricted fluid flow (back toward pump). If required, remove Flow Control Valve and install it correctly (**FIG. 12**).

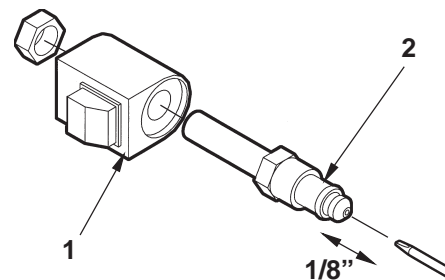

FIG. 11

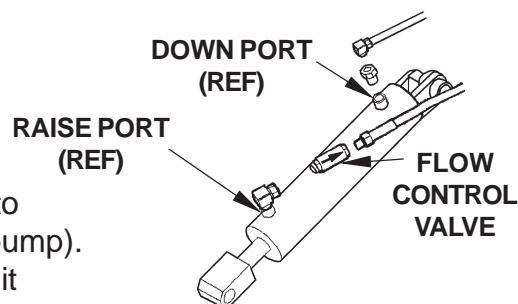

FIG. 12