

M-91-16
REV. 2
AUG. 1997

OPERATOR'S MANUAL

CONVENTIONAL LIFTGATE SERIES

TG-150 LM TG-20 LM

MAXON[®]
LIFT CORP.

11921 Slauson Avenue.
Santa Fe Springs, CA. 90670
(800) 227-4116

MAXON[®]

LIFT CORP.

**11921 Slauson Ave.
Santa Fe Springs, CA. 90670**

CUSTOMER SERVICE:

TELEPHONE (562) 464-0099 TOLL FREE (800) 227-4116

FAX: (888) 771-7713

**NOTE: Check with Customer Service for updated versions
of Manuals on an annual basis.**

WARRANTY POLICY & PROCEDURE

NEW LIFTGATE WARRANTY

Term of Warranty: 2 Years from Date of In-Service

Type of Warranty: Full Parts and Labor

MAXON agrees to replace any components which are found to be defective during the first 2 years of service, and will reimburse for labor based on MAXON's Liftgate Warranty Flat Rate Labor Schedule. (Call MAXON Customer Service for a copy).

All claims for warranty must be received within 30 Days of the repair date, and include the following information:

1. Liftgate Model Number
2. Liftgate Serial Number
3. Detailed Description of Problem
4. Corrective Action Taken, and Date of Repair.
5. Parts used for Repair, Including MAXON Part Number(s).
6. MAXON R.M.A. # and/or Authorization # if applicable (see below).
7. Person contacted at MAXON if applicable.

All warranty repairs must be performed by an authorized MAXON warranty station. For major repairs, MAXON Customer Service must be notified and an "Authorization Number" obtained. Major repairs would generally be considered repairs made to the structural assembly of the liftgate and/or repairs not outlined in the MAXON Liftgate Warranty Flat Rate Schedule.

Major components (i.e. hydraulic pumps, cylinders, valves, or failed structural parts) must be returned, freight pre-paid, prior to the claim being processed. To ensure timely processing of these warranty claims, an R.M.A. (Returned Merchandise Authorization) number must be obtained from MAXON Customer Service prior to the return of any defective part. Defective Parts must be returned within 60 days of the claim date for consideration to:

MAXON Lift Corp.

16205 Distribution Way, Cerritos, CA 90703

Attn: RMA#__

MAXON's warranty policy does not include the reimbursement for travel time, towing, vehicle rental, service calls, oil, batteries, defects due to misuse or abuse, or loss of income due to downtime. Fabrication of parts, which are available from MAXON, are also not covered.

MAXON's Flat Rate Labor Schedule takes into consideration the time required for diagnosis of a problem.

PURCHASE PART WARRANTY

Term of Warranty: 1 Year from Date of Purchase

Type of Warranty: Part Replacement

MAXON will guarantee all returned genuine replacement parts upon receipt and inspection of parts and invoice.

Table of Contents

WARNING	PAGE 4
DECALS	PAGE 5
LOWERING PLATFORM	PAGE 6
DOCK LOADING	PAGE 7
LOADING PLATFORM	PAGE 8
OPERATION & CLOSING OF PLATFORM.....	PAGE 9
SAFETY CHAIN LATCH	PAGE 10
FORKLIFT WARNING	PAGE 11

WARNING

- 1.** Read the **Operator's Manual** and understand it thoroughly before operating this unit.
- 2.** Read the urgent warning decal on the side of the vehicle close to the unit before operating.
- 3.** If decals are dirty, clean them. If decals are defaced or missing, replace them. **Free replacements** are available from the manufacturer. See information at the end of the Warnings !
- 4.** Be aware that the safety and location of other people or objects should be considered before operation of this unit. Stand to one side of platform while operating this unit.
- 5.** Do not stand under, or have any foreign object under the Platform when lowering. **Be sure that the lowering of the Platform and/or Flipover will miss your feet, and the raising of the platform will not trap your feet between the truck and the platform!**
- 6.** Keep fingers, hands, arms, legs, and feet clear of moving parts when operating this unit.
- 7.** If Platform is used as a ramp between vehicle and dock, DO NOT ALLOW ANY TRANSFER OF LOADS TO EXCEED THE RATED CAPACITY OF THIS UNIT!
- 8.** Do not allow children to ride, play with, or operate this unit.
- 9.** In the event of an emergency while operating the unit, release the toggle switch and the unit will stop immediately.
- 10.** A properly installed Lift should operate smoothly and the only noise during the operation of this unit should be from the Pump Unit during the raising of the Platform. Any scraping, grating or audible indications of rough operation will need investigating. The cause will need resolving before any further deterioration of performance occurs.
- 11.** Use only **Maxon Authorized Parts** for replacement. Replacement parts should be ordered from:

MAXON LIFT CORP. Parts Department
11921 Slauson Ave., Santa Fe Springs, Ca. 90670
Phone: (800) 227-4116

DECALS

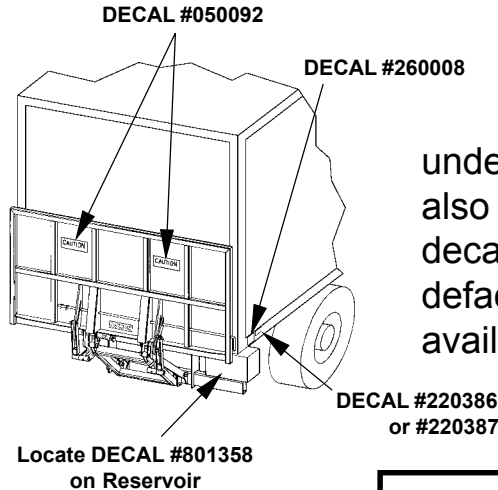

These Decals should be read and completely understood before operating the unit. They should also be kept clean and readable at all times. If any decal should become detached from the vehicle, or defaced, it must be replaced. Free replacements are available from: MAXON Lift Corp., Parts Department.

Suggested Decal Locations

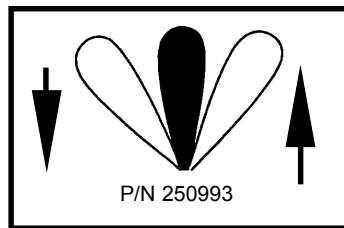

WARNING

READ CAREFULLY

- Improper operation of this Lift can result in serious personal injury. Do not operate unless you have been properly instructed and have read, and are familiar with the operating instructions. If you do not have a copy of the instructions, please obtain them from your employer, distributor, or lessor, before you attempt to operate Lift.
- Be certain that the vehicle is properly and securely braked before using the Lift.
- Always inspect this Lift for maintenance or damage before using it. If there are signs of improper maintenance, damage to vital parts, or slippery Platform surface, do not use the Lift until these problems have been corrected.
- Do not overload the Lift. The load limit is based on evenly distributed cargo over the entire Platform surface. If you are using a pallet jack, be sure it can be maneuvered safely. Do not operate a forklift on the Platform or travel with the platform in an open position at any time.
- Load should be placed in a stable position close to the edge of the Platform nearest the truck. The heaviest portion of the load should never be placed beyond the center of the Platform away from the truck.
- Never allow yourself, a helper, or bystander to stand in a position where a falling load could land on either of you. Also do not allow your's or your helper's feet to be placed under any portion of the lowering Lift.
- If a helper is riding the Platform with you, make sure you are both doing so safely and that you are not in danger of coming in contact with any moving or potentially moving obstacles. USE GOOD COMMON SENSE. If load appears to be unsafe, do not lift or lower it.

MAXON LIFT CORP.
PART NO. 260008

CAUTION!

DO NOT USE BRAKE FLUID...
USE: No. 10W S.A.E. Motor Oil
Hydraulic Hoist Oil
Type "A" Transmission Fluid
"Fill only when lift is lowered to
ground" P/N 801358

THE MAXIMUM CAPACITY OF
THIS LIFT IS

1500 LBS.

WHEN THE LOAD IS
CENTERED ON THE LOAD
CARRYING PLATFORM

P/N 220386

THE MAXIMUM CAPACITY OF
THIS LIFT IS

2000 LBS.

WHEN THE LOAD IS
CENTERED ON THE LOAD
CARRYING PLATFORM

P/N 220387

11921 Slauson Ave. Santa Fe Springs, CA. 90670 (800) 227-4116 FAX (562) 698-0187



LOWERING PLATFORM

1. Be certain the vehicle is properly and securely braked before beginning any operation involving this lift gate.

Un-hook Safety Chain Latch from hasp on the side of the Platform.

SAFETY CHAIN

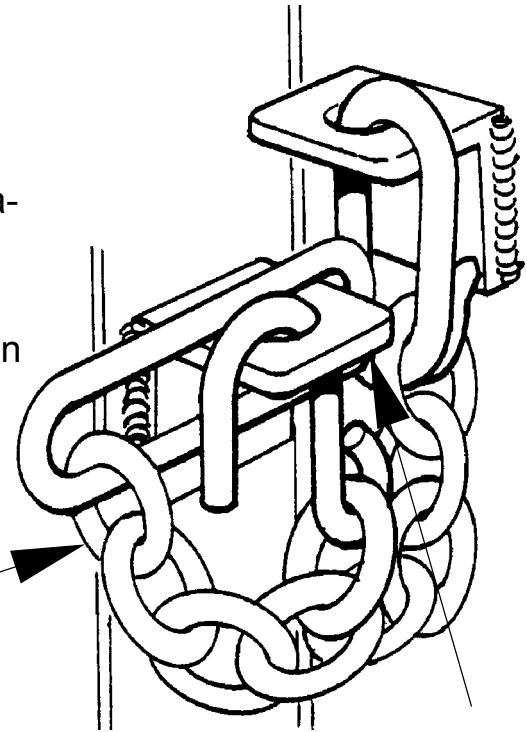

HASP

2. Use Toggle Switch to lower the Platform. Be aware that the safety and location of other people or objects should be considered before operation of this unit. Stand to one side of platform while operating this unit. When shackles and platform touch the ground, release the Toggle Switch.

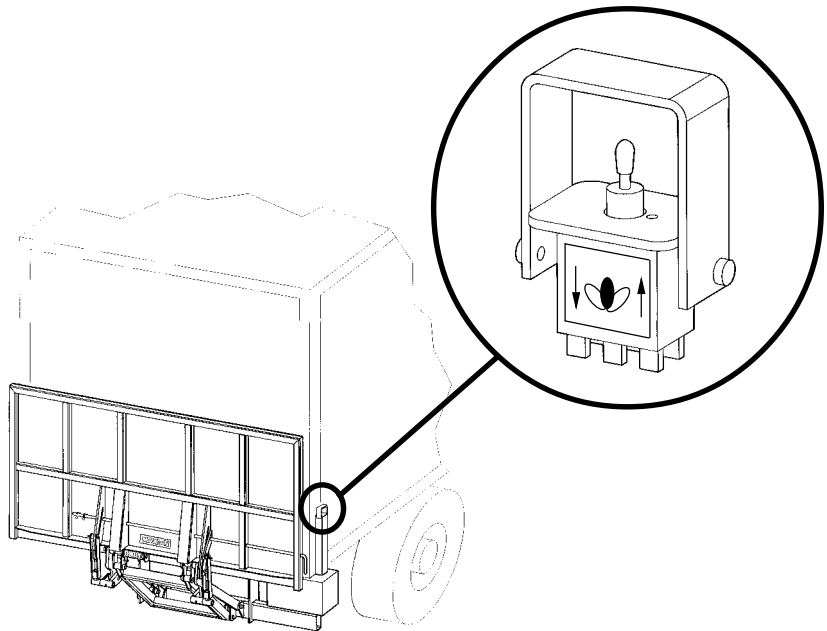

DOCK LOADING

NOTE: Conventional style liftgates, such as the TG-LM Series, are not recommended for dock deliveries. However, if the vehicles bed height is higher than the dock floor, the liftgate platform may be used to load/unload cargo.

1. While allowing for clearance between the liftgate and the dock, lower the Platform to allow the Closer Assembly to completely dis-engage.
2. Raise the opened Platform to bed height by activating the Toggle Switch. Once the Platform reaches the bed height, release the switch.
3. Back the vehicle over the dock area, allowing approximately 12" of the Platform to overlap the dock. Once the vehicle is properly and securely braked, activate the Toggle Switch to lower the Platform to the dock. When the Platform rests on the Dock, release the Toggle Switch.
4. After loading/unloading, raise the Platform to bed height and pull the vehicle clear of the dock. Lower the Platform to the ground. Hold the curb-side handle down while raising the Platform via the Toggle Switch. This will engage the Closing mechanism. Continue to raise the Platform until it is in a vertical position against the vehicle, then release the switch. Secure the Safety Chain Latch.
(See Safety Chain Latch page).

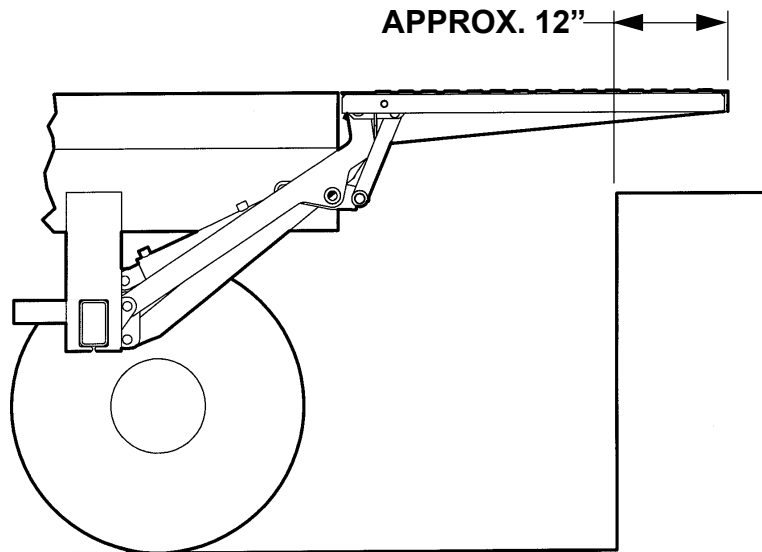

LOADING PLATFORM

The loading procedures are the same for loading from the ground, from the vehicle's bed, or from a dock.

1. Load must not be greater than the rated capacity for the unit. (1500 lbs. for the TG-150LM, and 2000 lbs. for the TG-20LM).
2. Load shall be placed and distributed centrally, about the geometric center of the lifting area. (**NOTE:** If your Platform has an inclined loading ramp, no load may be placed on this ramp. It is **not** a load bearing member.)
3. The heaviest object being loaded should be placed in the center of the lifting area near, (but not exceeding), the edge closest to the vehicle floor, and not to one side of the Platform. No part of the load shall hang over the edges of the Platform.
4. **WARNING!** Extreme care must be taken when operating a loaded Platform. Always be sure that children or other persons are clear of the Platform area.
5. Prior to lifting the Platform off of the ground, check that the Platform Closer is disengaged.

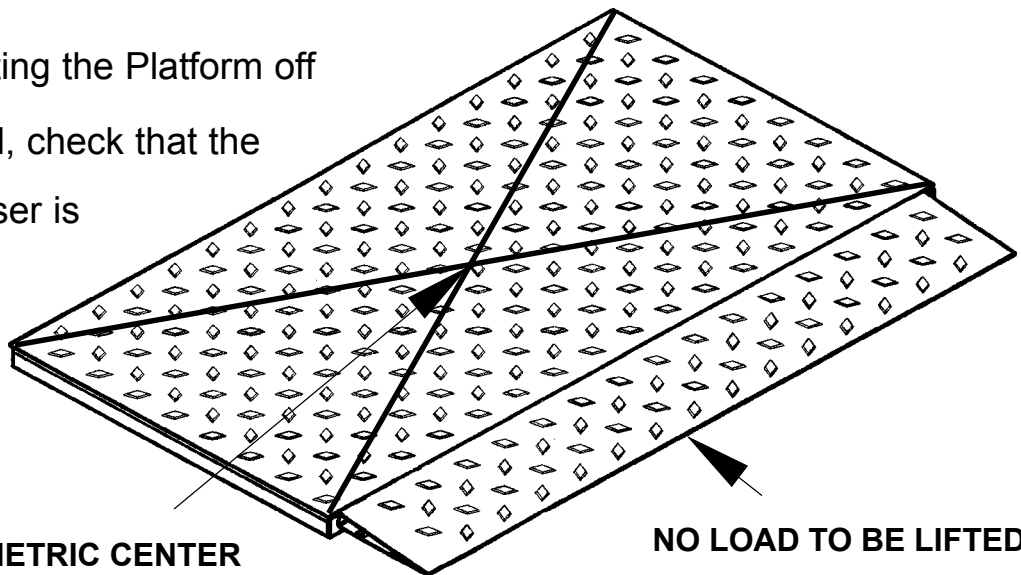

GEOMETRIC CENTER
OF LIFTING AREA

NO LOAD TO BE LIFTED
ON THE RAMP

OPERATION & CLOSING OF PLATFORM

NORMAL OPERATION:

With the Platform in the open position, lower the Platform by pushing the Toggle Switch to the left. Raise the Platform by pushing the Toggle Switch to the right. Once the Platform has reached the desired position, release the switch.

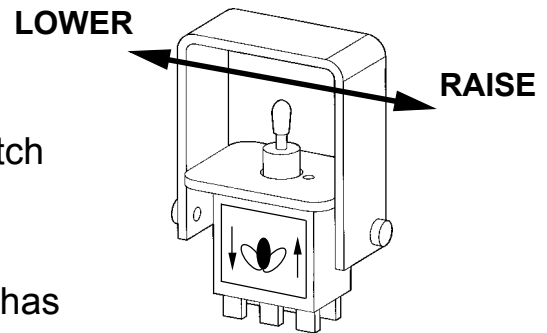

PLATFORM CLOSING:

Lower the Platform to the ground. Hold the curb-side handle down while raising the Platform via the Toggle Switch. Continue to hold down the handle until you feel the engagement of the Closing Mechanism. Raise the Platform until it is in a vertical position against the vehicle, then release the switch. Secure the Safety Chain Latch.

(See Safety Chain Latch page).

HOLD HANDLE DOWN UNTIL THE CLOSING MECHANISM ENGAGES, THEN RELEASE THE HANDLE.

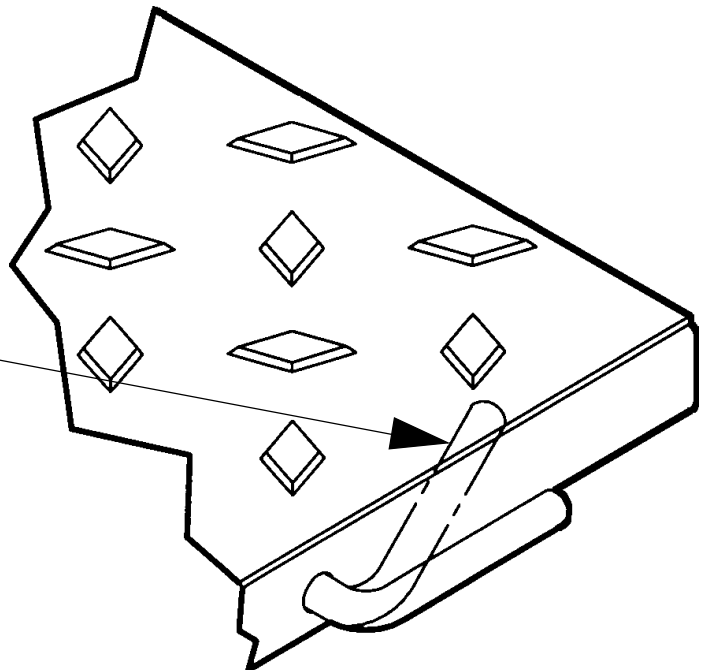

SAFETY CHAIN LATCH

IMPORTANT! Loop "S" hook from underneath the hasp as shown.

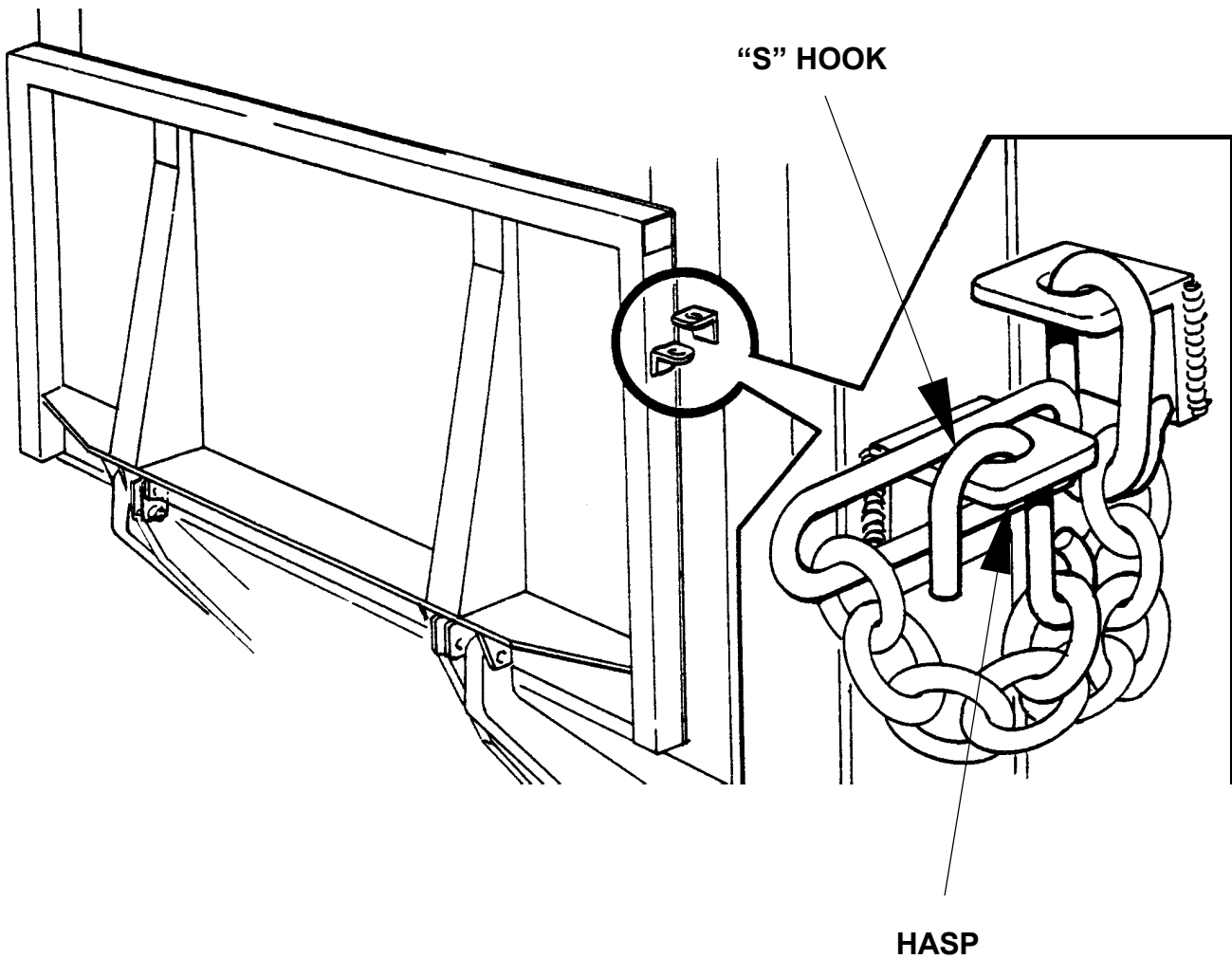

MAXON[®]

11921 Slauson Ave. Santa Fe Springs, CA. 90670 (800) 227-4116 FAX (562) 698-0187

FORKLIFT WARNING

KEEP FORKLIFTS OFF OF PLATFORM

