

# MAXON®

## 72-150SA • TE-20SA MAINTENANCE

### MANUAL

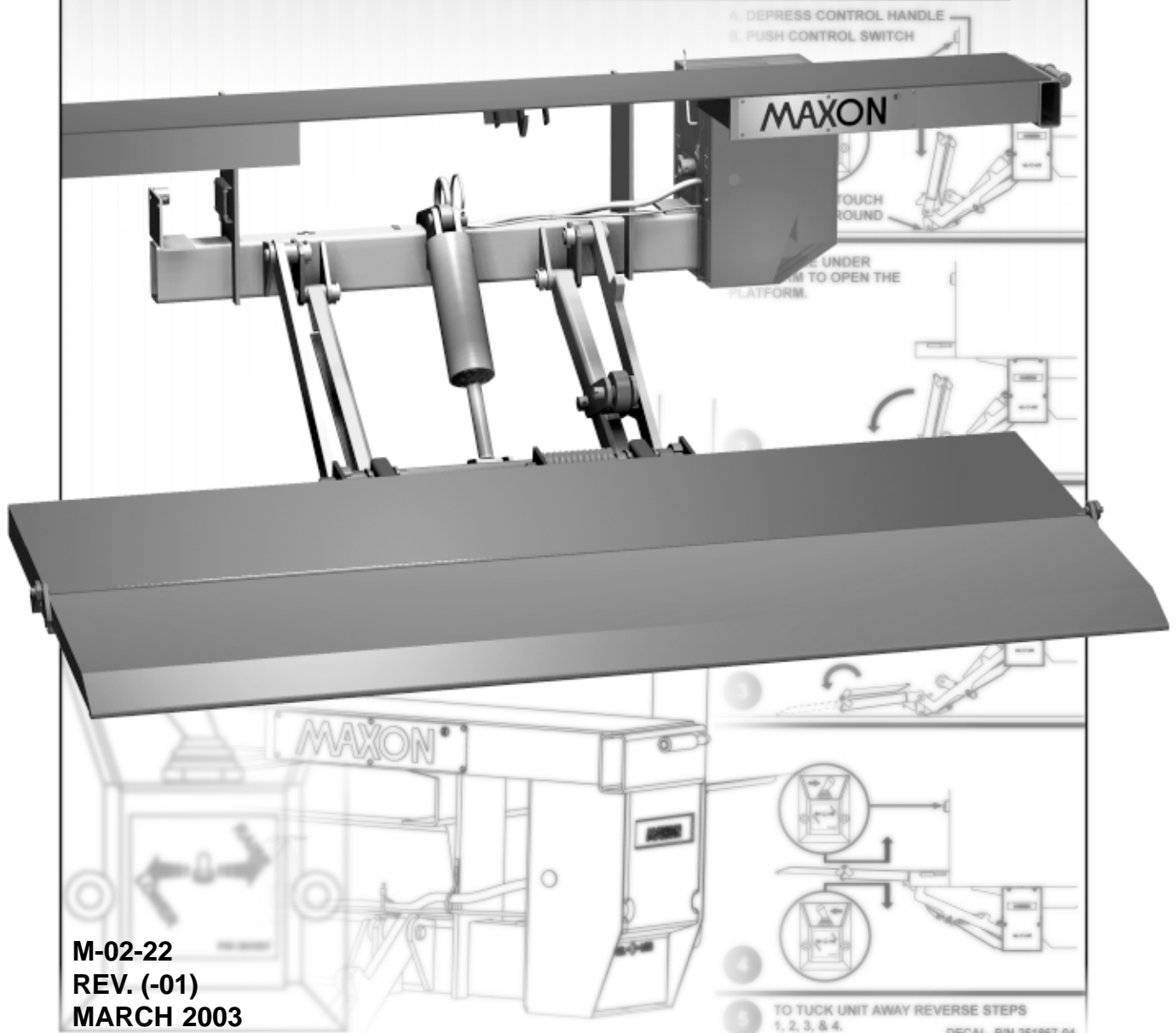

M-02-22  
REV. (-01)  
MARCH 2003

TO TUCK UNIT AWAY REVERSE STEPS  
1, 2, 3, & 4.  
DECAL, PIN 251887-04



# MAXON<sup>®</sup>

## LIFT CORP.

11921 Slauson Ave.  
Santa Fe Springs, CA. 90670

### CUSTOMER SERVICE:

TELEPHONE (562) 464-0099 TOLL FREE (800) 227-4116

FAX: (888) 771-7713

NOTE: For latest version Manuals (and replacements), download  
Manuals from Maxon's website at [www.maxonlift.com](http://www.maxonlift.com).

## WARRANTY/ RMA POLICY & PROCEDURE

### LIFTGATE WARRANTY

Term of Warranty: 2 Years from Date of In-Service (In service date cannot exceed 3 months from ship date.)

Type of Warranty: Full Parts and Labor

This warranty shall not apply unless the product is installed, operated and maintained in accordance with MAXON Lift's specifications as set forth in MAXON Lift's Installation, Operation and Maintenance manuals. This warranty does not cover normal wear, maintenance or adjustments, damage or malfunction caused by improper handling, installation, abuse, misuse, negligence, or carelessness of operation. In addition, this warranty does not cover equipment that has had unauthorized modifications or alterations made to the product.

MAXON agrees to replace any components which are found to be defective during the first 2 years of service, and will reimburse for labor based on MAXON's Liftgate Warranty Flat Rate Schedule. (Copy of the Flat Rate is available at [www.maxonlift.com](http://www.maxonlift.com).)

All warranty repairs must be performed by an authorized MAXON warranty facility. For any repairs that may exceed \$500, including parts and labor, MAXON's Technical Service Department must be notified and an "Authorization Number" obtained.

All claims for warranty must be received within 30 Days of the repair date, and include the following information:

1. Liftgate Model Number and Serial Number
2. The End User must be referenced on the claim
3. Detailed Description of Problem
4. Corrective Action Taken, and Date of Repair
5. Parts used for Repair, Including MAXON Part Number(s)
6. MAXON R.M.A. # and/or Authorization # if applicable (see below)
7. Person contacted at MAXON if applicable
8. Claim must show detailed information i.e. Labor rate and hours of work performed

Warranty claims can also be placed on-line at [www.maxonlift.com](http://www.maxonlift.com). On-line claims will be given priority processing.

All claims for warranty will be denied if paperwork has not been received or claim submitted via Maxon website for processing by MAXON's Warranty Department within 30 days of repair date.

All components may be subject to return for inspection, prior to the claim being processed. MAXON products may not be returned without prior written approval from MAXON's Technical Service Department. Returns must be accompanied by a copy of the original invoice or reference with original invoice number and are subject to a credit deduction to cover handling charges and any necessary reconditioning costs. **Unauthorized returns will be refused and will become the responsibility of the returnee.**

Any goods being returned to MAXON Lift must be pre-approved for return, and have the R.M.A. number written on the outside of the package in plain view, and returned freight prepaid. All returns are subject to a 15% handling charge if not accompanied by a detailed packing list. Returned parts are subject to no credit and returned back to the customer.

Defective Parts requested for return must be returned within 30 days of the claim date for consideration to:

**MAXON Lift Corp.**  
**16205 Distribution Way, Cerritos, CA 90703**

Attn: RMA#\_\_\_

MAXON's warranty policy does not include the reimbursement for travel time, towing, vehicle rental, service calls, oil, batteries or loss of income due to downtime. Fabrication or use of non Maxon parts, which are available from MAXON, are also not covered.

MAXON's Flat Rate Labor Schedule takes into consideration the time required for diagnosis of a problem.

All Liftgates returned are subject to inspection and a 15% restocking fee. Any returned Liftgates or components that have been installed or not returned in new condition will be subject to an additional reworking charge which will be based upon the labor and material cost required to return the Liftgate or component to new condition.

### PURCHASE PART WARRANTY

Term of Warranty: 1 Year from Date of Purchase.

Type of Warranty: Part replacement only

MAXON will guarantee all returned genuine MAXON replacement parts upon receipt and inspection of parts and original invoice.

All warranty replacements parts will be sent out via ground freight. If a Rush Shipment is requested all freight charges will be billed to the requesting party.

# TABLE OF CONTENTS

<b>WARNINGS</b> .....	<b>6</b>
LIFTGATE TERMINOLOGY .....	7
PERIODIC MAINTENANCE CHECKLIST .....	8
CHANGING HYDRAULIC FLUID .....	9
PLATFORM ADJUSTMENT .....	10
REPLACING PLATFORM TORSION SPRING .....	12
SAFETY HOOK MAINTENANCE .....	14
<b>PARTS BREAKDOWN</b> .....	<b>15</b>
72-150SA/TE-20SA FINAL ASSEMBLY .....	16
EXTENSION PLATE ASSEMBLY .....	17
LIFT FRAME & PARALLEL ARMS .....	18
PLATFORM & FLIPOVER ASSEMBLY .....	20
PUMP COVER .....	21
GRAVITY DOWN HYDRAULIC COMPONENTS .....	22
12 VDC POWER UNIT (GRAVITY DOWN) .....	23
POWER DOWN HYDRAULIC COMPONENTS .....	24
12 VDC POWER UNIT (POWER DOWN) .....	25
DECALS .....	26
CONTROL SWITCH AND POWER CABLE .....	27
<b>SCHEMATICS</b> .....	<b>28</b>
HYDRAULIC SCHEMATIC (GRAVITY DOWN) .....	29
ELECTRICAL SCHEMATIC - GRAVITY DOWN .....	30

## TABLE OF CONTENTS - Continued

HYDRAULIC SCHEMATIC - POWER DOWN .....	31
ELECTRICAL SCHEMATIC - POWER DOWN .....	32
<b>TROUBLESHOOTING .....</b>	<b>33</b>
PLATFORM WILL NOT RAISE .....	34
PLATFORM RAISES BUT LEAKS DOWN .....	35
PLATFORM RAISES PARTIALLY AND STOPS .....	36
LIFTGATE WILL NOT LIFT RATED CAPACITY .....	37
PLATFORM RAISES SLOWLY .....	38
PLATFORM WILL NOT LOWER, LOWERS TOO SLOWLY, OR LOWERS TOO QUICKLY ..	39

Comply with the following **WARNINGS** while maintaining Liftgates. See Operation Manual M-02-21 for operating safety requirements.

## **WARNINGS**

- Read and understand the instructions in this **Maintenance Manual** before performing maintenance on the Liftgate.
- Before operating the Liftgate, read and understand the operating instructions in **Operation Manual M-02-21**.
- Comply with all **WARNING** and instruction decals attached to the Liftgate.
- Keep decals clean and legible. If decals are defaced or missing, replace them. Free replacement decals are available from **Maxon Parts Department**.
- Consider the safety and location of bystanders and location of nearby objects when operating the Liftgate. Stand to one side of the platform while operating the Liftgate
- Do not allow untrained persons to operate the Liftgate.
- Do not stand under, or allow obstructions under the platform when lowering the Liftgate. **Be sure your feet are clear of the Liftgate.**
- **Keep fingers, hands, arms, legs, and feet clear of moving Liftgate parts (and platform edges) when operating the Liftgate.**
- **Correctly stow platform when not in use. Extended platforms could create a hazard for people and vehicles passing by.**
- **Disconnect Liftgate power cable from battery** before repairing or servicing Liftgate.
- Wear appropriate safety equipment such as protective eyeglasses, faceshield and clothing while performing maintenance on the Liftgate and handling the battery. Debris from drilling and contact with battery acid may injure unprotected eyes and skin.
- Be careful working by an automotive type battery. Make sure the work area is well ventilated and there are no flames or sparks near the battery. Never lay objects on the battery that can short the terminals together. If battery acid gets in your eyes, immediately seek first aid. If acid gets on your skin, immediately wash it off with soap and water.
- If an emergency situation arises (vehicle or Liftgate) while operating the Liftgate, release the control Toggle Switch and the Liftgate will stop.
- A correctly installed Liftgate operates smoothly and reasonably quiet. The only noticeable noise during operation comes from the pump unit while the platform is raised. Listen for scraping, grating and binding noises and correct the problem before continuing to operate Liftgate.
- If it is necessary to stand on the platform while maintaining the Liftgate, keep your feet and any objects clear of the inboard edge of the platform. Your feet or objects on the platform could be trapped between the platform and the Liftgate extension plate.
- Never perform unauthorized modifications on the Liftgate. Modifications may result in early failure of the Liftgate and may create hazards for Liftgate operators and maintainers.
- Use only **Maxon Authorized Parts** for replacement parts. Provide Liftgate model and serial number information with your parts order. Order replacement parts from:

**MAXON LIFT CORP. Customer Service**  
**11921 Slauson Ave., Santa Fe Springs, CA 90670**  
**Phone: (800) 227-4116**

- To order parts by e-mail, submit orders to [partssales@maxonlift.com](mailto:partssales@maxonlift.com).

# LIFTGATE TERMINOLOGY

## 72-150SA & TE-20SA

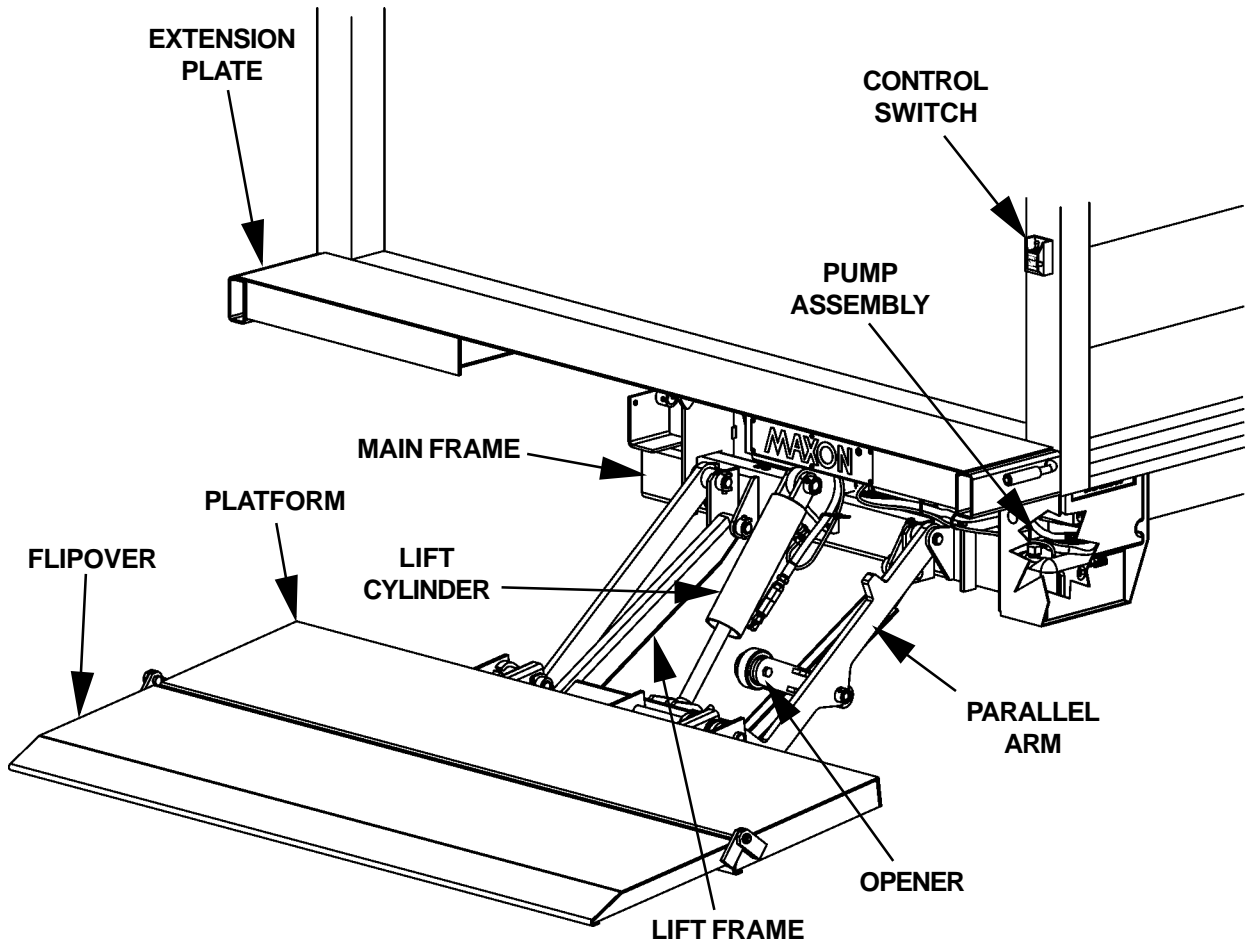

# PERIODIC MAINTENANCE CHECKLIST

## WARNING

Never operate the Liftgate with parts loose or missing.

### Annually

Visually check the entire Liftgate for excessively worn parts and broken welds, especially the Hinge Pins. See **PARTS BREAKDOWN** section for replacement parts. Also, do the **Semi-annual** and **Quarterly Maintenance** checks.

### Semi-annually

Visually check the Platform Hinge Pins for excessive wear and broken welds. See **PARTS BREAKDOWN** section for replacement parts. Also, do the **Quarterly Maintenance** checks.

### Quarterly

Check the Hydraulic Fluid level in the Pump Reservoir. If hydraulic fluid must be added, select the correct grade of fluid to use at your location. Recommended hydraulic fluids are listed in **TABLE 1** and **TABLE 2**

**+40 to +150 Degrees F - Grade ISO 32**  
**Below + 40 Degrees F - Grade ISO 15**

ISO 32 HYDRAULIC FLUID	
RECOMMENDED BRANDS	PART NUMBER
ROSEMEAD	HYDRAULIM MV 150
CHEVRON	HYDRAULIC OIL AW MV 32
SHELL	TELLUS T 32
EXXON	UNIVIS N 32
MOBIL	HYDRAULIC OIL 13

**TABLE 1**

ISO 15 HYDRAULIC FLUID	
RECOMMENDED BRANDS	PART NUMBER
EXXON	UNIVIS J13
EXXON	MIL-L-5606 A
CHEVRON	AVIATION HYDRAULIC FLUID A
SHELL	AEROSHELL FLUID 4
MOBIL	AERO HFA

**TABLE 2**

If Hydraulic Fluid appears contaminated, refer to the **CHANGING HYDRAULIC FLUID** procedure on following page.

Keep track of the grade of Hydraulic Fluid in the Pump Reservoir and never mix two different grades of fluid.

Check all Hoses and Fittings for chaffing and fluid leaks. Replace if necessary.

Check electrical wiring for chaffing and make sure wiring connections are tight and free of corrosion.

Check that all **WARNING** and **instruction decals** are in place and legible.

Check that all roll pins are in place and protrude evenly from both sides of Hinge Pin collar. Replace roll pins if necessary.



# CHANGING HYDRAULIC FLUID

## CAUTION

Keep dirt, water and other contaminants from entering the hydraulic system. Before opening the hydraulic fluid reservoir filler cap, drain plug and hydraulic lines, clean up contaminants that can get in the openings. Also, protect the openings from accidental contamination.

### GRAVITY DOWN LIFTGATES

1. Remove the Pump Cover. Place empty 5 Gallon Bucket under Drain Plug (FIG. 1).
2. Lower Platform to ground. Pull out (no threads) Drain Plug (FIG. 1). Drain hydraulic fluid from system. Re-install Drain Plug.
3. Pull out (no threads) Filler Cap (FIG. 1) and refill reservoir with Hydraulic Fluid to 4" level shown in FIG. 1. Use correct grade of hydraulic fluid for your location. See TABLE 1 and TABLE 2 for recommended fluids.  
**+40 to +150 Degrees F - Grade ISO 32**  
**Below + 40 Degrees F - Grade ISO 15**
4. Reinstall Filler Cap (FIG. 1).

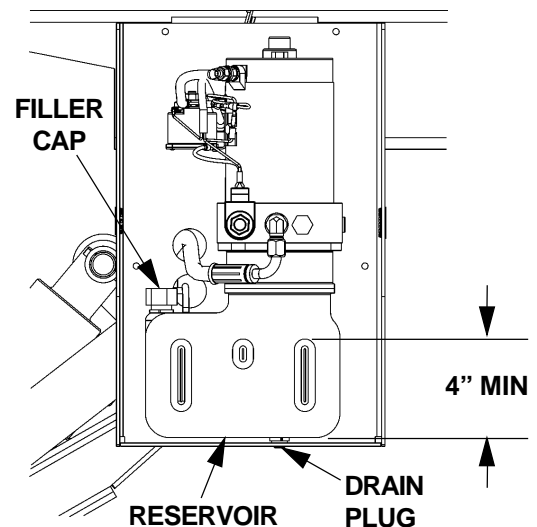

LIFTGATE SHOWN WITH GRAVITY DOWN PUMP & MOTOR  
FIG. 1

### POWER DOWN LIFTGATES

1. Remove the Pump Cover. Place empty 5 Gallon Bucket under Drain Plug (FIG. 1).
2. Open and raise Platform to vehicle bed height. Pull out (no threads) Drain Plug (FIG. 1). Drain hydraulic fluid.
3. Disconnect the Motor Power Cable (FIG. 2) from bottom Starter Solenoid. Lower the Platform while draining the remaining hydraulic fluid from system. Reinstall Drain Plug. Reconnect the Motor Power Cable to bottom Starter Solenoid.
4. Pull out (no threads) Filler Cap (FIG. 1) and refill reservoir with Hydraulic Fluid to 4" level shown in FIG. 1. Use correct grade of hydraulic fluid for your location. See TABLE 1 and TABLE 2 for recommended fluids.  
**+40 to +150 Degrees F - Grade ISO 32**  
**Below +40 Degrees F - Grade ISO 15**
5. Raise Platform to vehicle bed height. Check hydraulic fluid again and, if needed, add more hydraulic fluid until Sight Glass (FIG. 1) is half full.
6. Reinstall Filler Cap (FIG. 1).

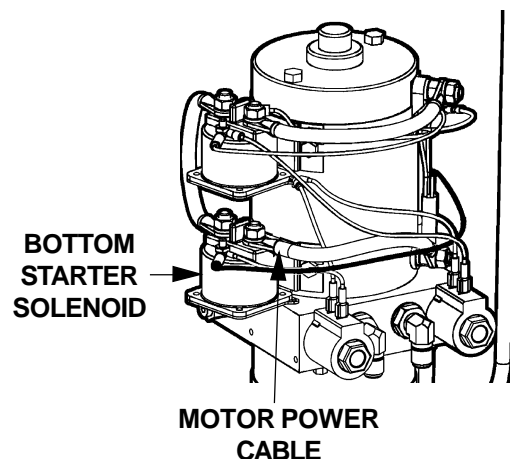

POWER DOWN PUMP  
FIG. 2

# PLATFORM ADJUSTMENT

**NOTE:** Before doing the following procedure, make sure vehicle is parked on level ground.

1. Make sure Platform is at ground level. Unfold the Platform and Flipover. The Shackles and the outboard edge of Platform must touch the ground at the same time as shown in **FIG. 4**. If the Shackles and the outboard edge of Platform are touching the ground, **RAISE** Platform to bed height. Outboard edge of Platform should be above bed level (**FIG. 3**). If indications are correct (**FIGS. 3 & 4**), Liftgate is installed correctly and no adjustment is needed. If indications are incorrect, continue with instruction 2.

**NOTE:** If the Platform is like **FIG. 5**, do instruction 2. If the Platform touches and the Shackle does not (**FIG. 8**), skip 2 and do 3.

2. Make sure Platform is still at ground level. If the Shackle is not touching the ground, measure and compare distance "A" (**FIG. 5**) with **TABLE 3** to determine the correct shim. Make shims as needed (**FIG. 6**). Weld shim as shown in **FIG. 7**.

RAISE PLATFORM EDGE (OUTBOARD) THIS DISTANCE ("A")	REQUIRED SHIM THICKNESS	WELD SIZE "W"
11/16"	1/16"	1/16"
1-3/8"	1/8"	1/8"
2-1/16"	3/16"	3/16"
2-3/4"	1/4"	1/4"

**TABLE 3**

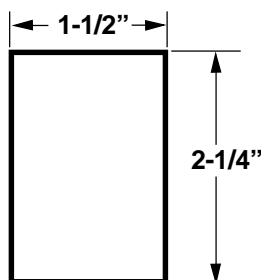

**SHIM (1/16", 1/8", 3/16", or 1/4")  
MADE FROM STEEL FLAT  
FIG. 6**

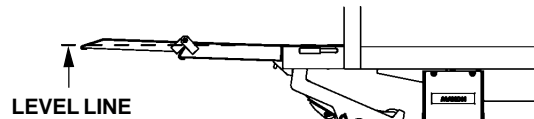

**PLATFORM EDGE ABOVE BED LEVEL  
FIG. 3**

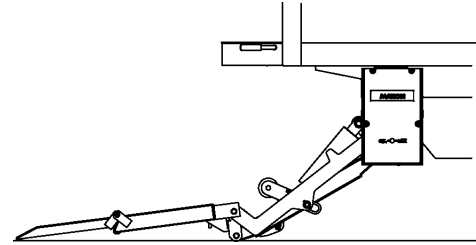

**PLATFORM & SHACKLES  
TOUCH GROUND  
FIG. 4**

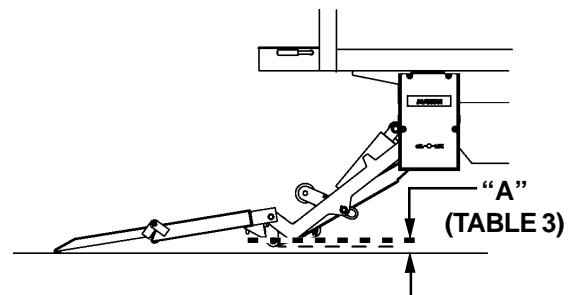

**SHACKLES DO NOT TOUCH GROUND  
FIG. 5**

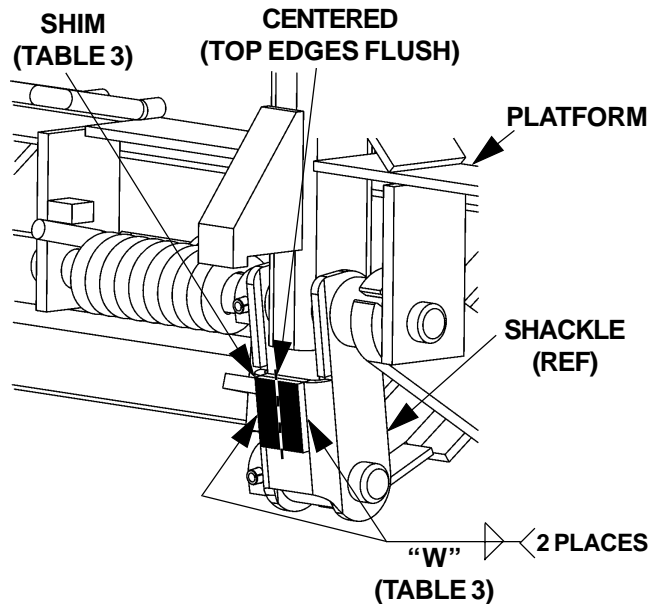

**WELDING SHIMS (CURBSIDE SHOWN)  
FIG. 7**

**MAXON**

11921 Slauson Ave. Santa Fe Springs, CA. 90670 (800) 227-4116 FAX (888) 771-7713

## PLATFORM ADJUSTMENT - Continued

3. Make sure Platform is still at ground level. If the Platform is not touching the ground, measure and compare distance "B" (FIG. 8) with TABLE 4 to determine how much to grind from the Platform Stops (FIG. 9). Grind correct amount of metal (TABLE 4) from Platform Stop as shown in FIG. 9.

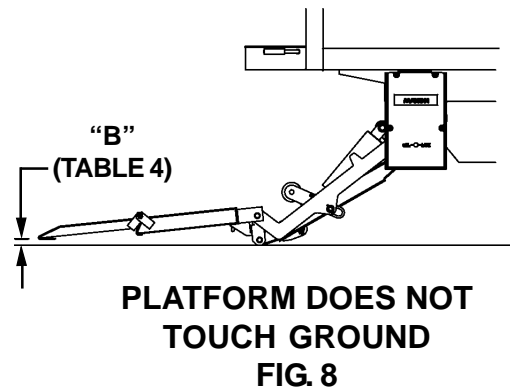

LOWER PLATFORM EDGE (OUTBOARD) THIS DISTANCE("B")	GRIND METAL FROM PLATFORM STOP
11/16"	1/16"
1-3/8"	1/8"
2-1/16"	3/16"
2-3/4"	1/4"

TABLE 4

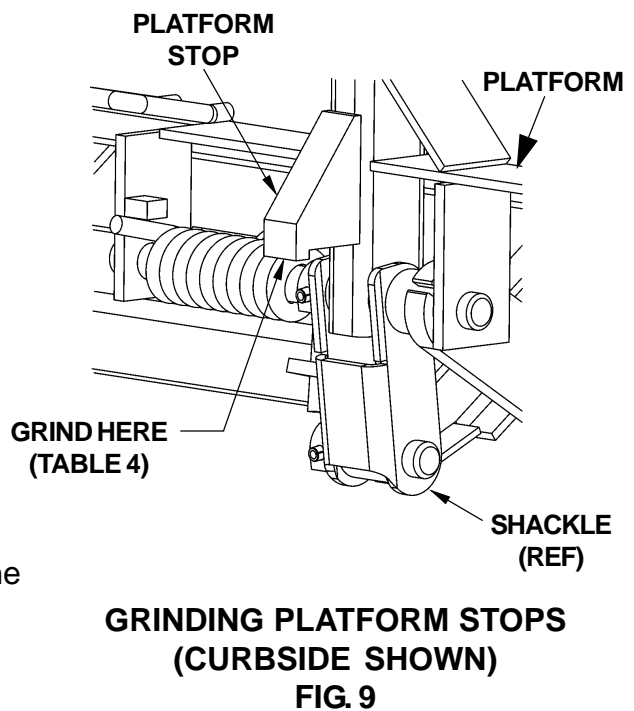

4. **RAISE** the Platform, then **LOWER** it to the ground. Platform and Shackle should touch the ground at the same time as shown in FIG. 4.

# REPLACING PLATFORM TORSION SPRING

**MAXON**<sup>®</sup>

11921 Slauson Ave. Santa Fe Springs, CA. 90670 (800) 227-4116 FAX (888) 771-7713

1. Manually fold Flipover onto Platform .
2. Raise Liftgate to a convenient work height to gain access and release tension on the Torsion Spring.

## ⚠ CAUTION

To prevent injury and equipment damage, make sure there is no tension on torsion spring before removing hinge pin.

3. Drive out the roll pin from pin collar on the Platform Hinge Bracket. Drive the platform Hinge Pin outboard from the Shackle just enough to free the torsion spring (**FIG. 10**). Remove spring from Shackle.
4. Install the Torsion Spring as shown in (**FIG. 11**). Make sure the long leg of the spring is inserted in the bracket located on the Shackle. Make sure the short end of the spring is visible and resting against the block on the Platform Hinge Bracket (**FIG. 11**).

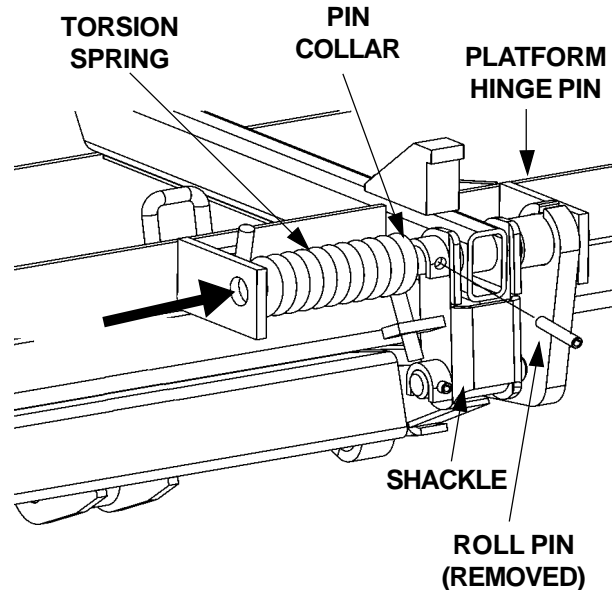

FIG. 10

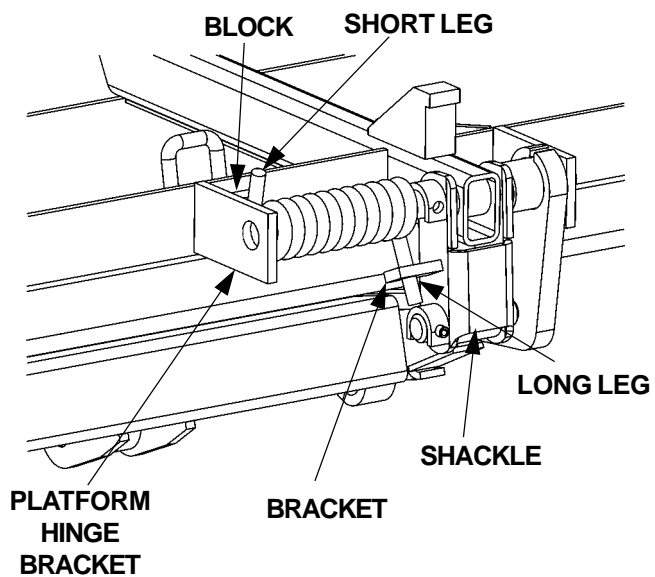

FIG. 11

# REPLACING PLATFORM TORSION SPRING -Continued

5. Drive Platform Hinge Pin inboard to correct position through the Platform Hinge Bracket (**FIG. 12**). Line up the hole in the Platform Hinge Pin with the hole in the Pin Collar. Install the roll pin through the Pin Collar until roll pin protrudes equally from both sides of the collar (**FIG. 12**).
6. Operate the Liftgate according to instructions in **Operation Manual M-02-21** to make sure it operates correctly.

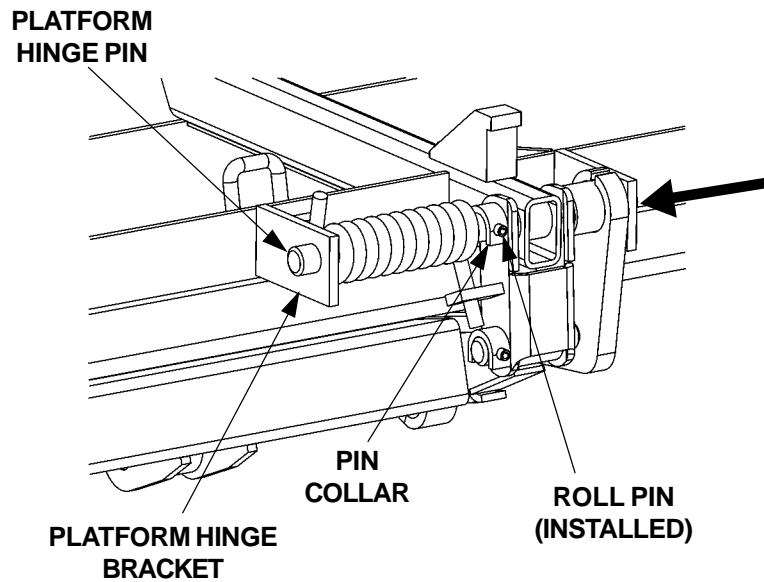
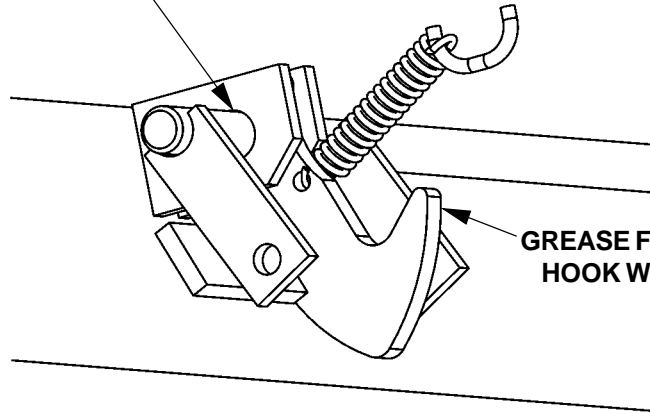

FIG. 12

# SAFETY HOOK MAINTENANCE

GREASE ALL HOLES THE  
ROD PASSES THRU



GREASE FRONT SURFACE OF  
HOOK WITH AUTOMOTIVE  
GREASE

FIG. 13

## CHECK SAFETY HOOK FUNCTION

1. When raising Platform to stowed position, listen for sound of **Platform Loop** striking **Safety Hook**.
2. When the Liftgate is stowed, see if **Platform Loop** is positioned above the **Safety Hook** as shown in **FIG. 13**.

## LOOP ADJUSTMENT

1. If the Safety Hook is not positioned correctly, **LOWER** Platform to ground level (**Operation Manual M-02-21**).
2. Adjust by bending the Platform Loop as shown in **FIG. 14**.
3. Stow the Platform and check for correct Safety Hook position. Repeat adjustment if required.

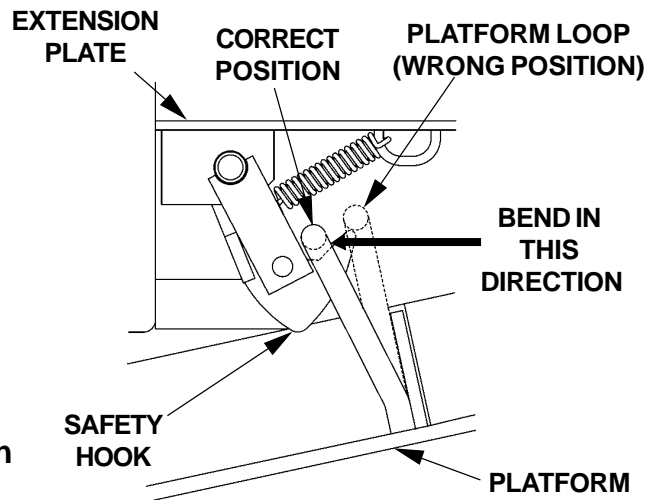

FIG. 14

**MAXON**<sup>®</sup>

11921 Slauson Ave. Santa Fe Springs, CA. 90670 (800) 227-4116 FAX (888) 771-7713

# PARTS BREAKDOWN

# 72-150SA/TE-20SA FINAL ASSEMBLY

**MAXON®**

11921 Slauson Ave. Santa Fe Springs, CA. 90670 (800) 227-4116 FAX (888) 771-7713

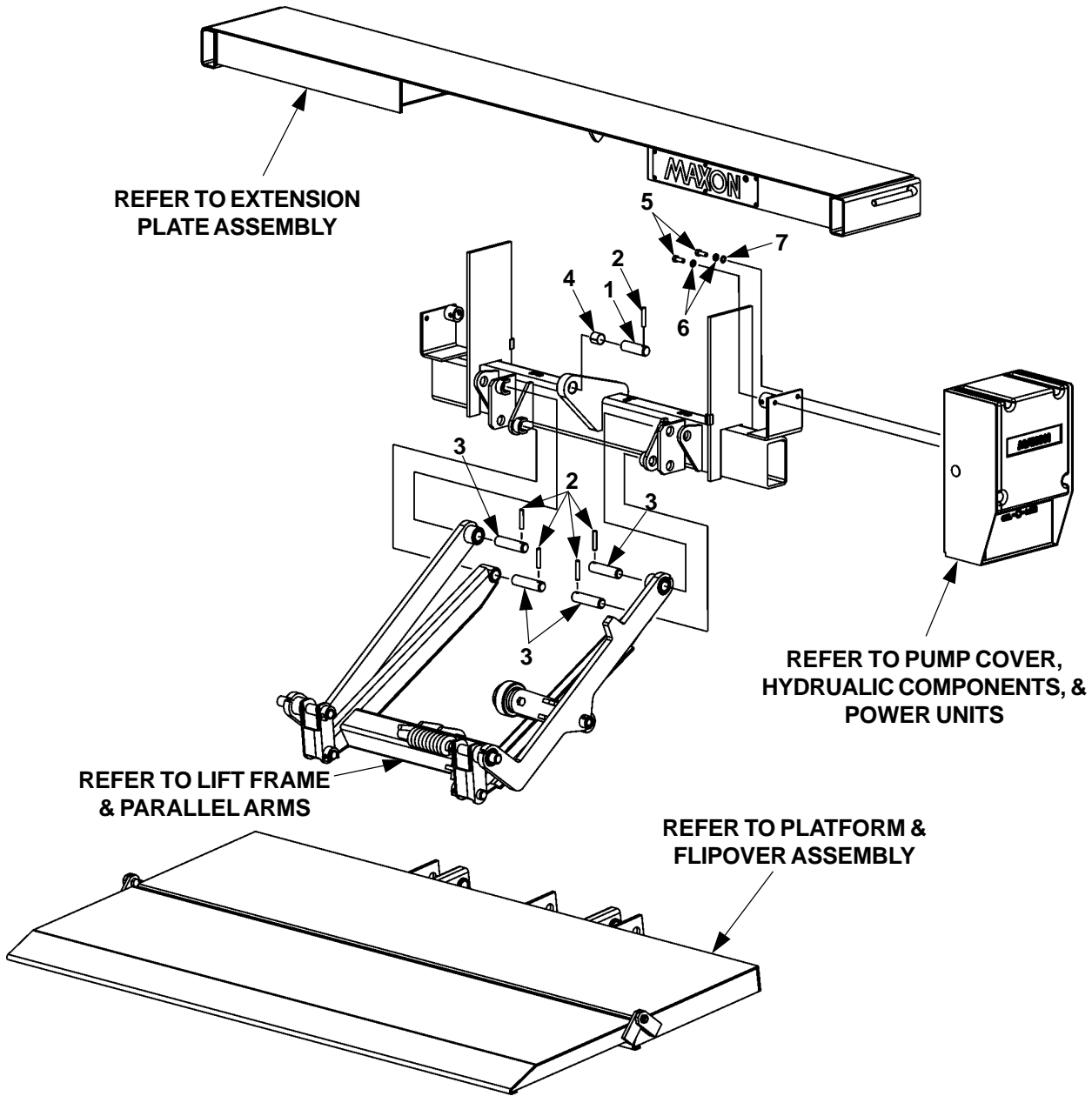

ITEM	QTY.	PART NO.	DESCRIPTION
1	1	203405-05	PIN, 3-1/4" LG.
2	5	221416	ROLL PIN
3	4	252686	PIN, 4" LG.
4	1	253657	BEARING, SELF LUBE
5	2	900014-04	HEX HD BOLT, 3/8"-16 x 1" LG.
6	2	902011-04	LOCK WASHER, 3/8"
7	1	903400-02	LOCK WASHER, EXTERNAL TOOTH, 3/8"



# EXTENSION PLATE ASSEMBLY

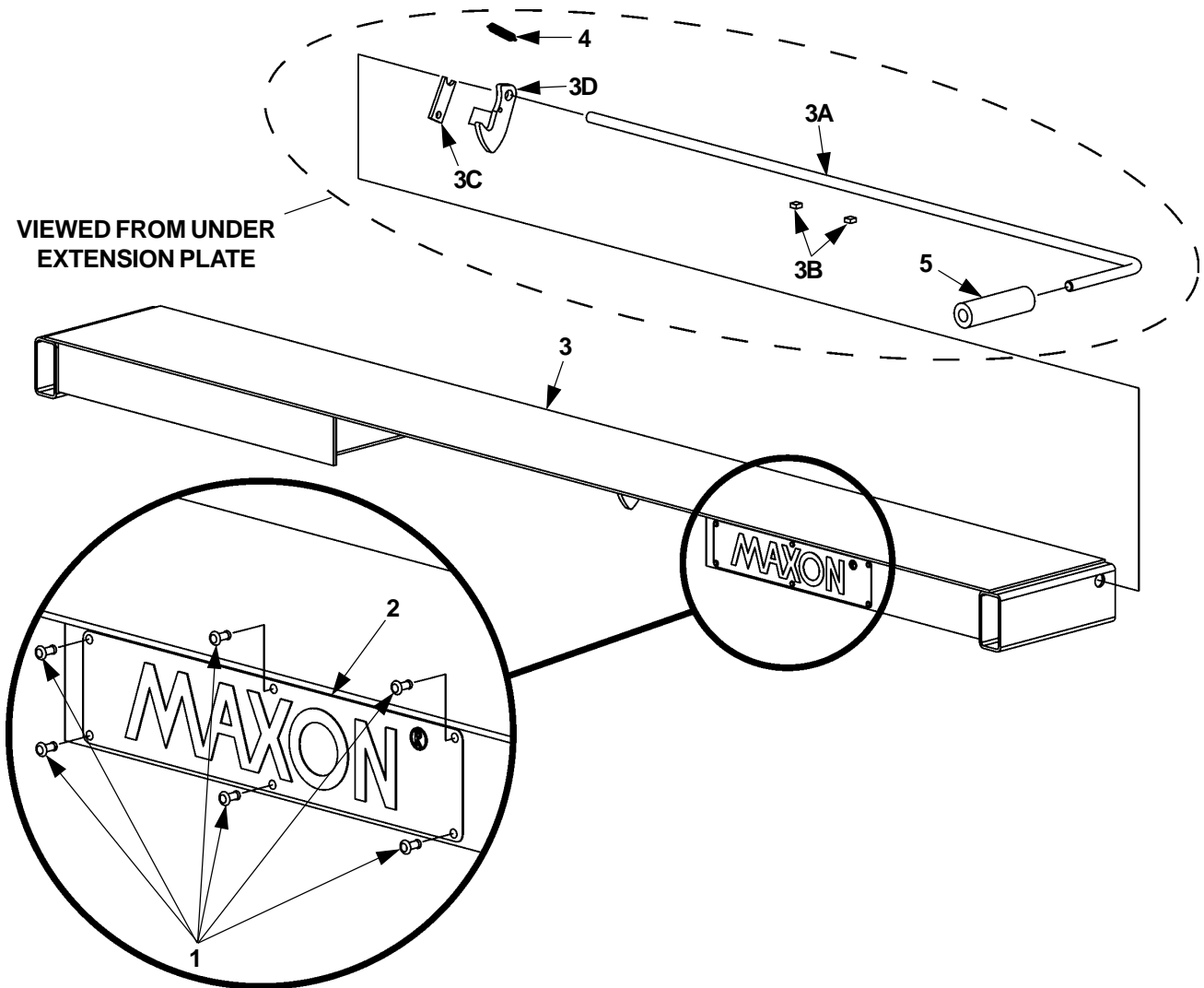

ITEM	QTY.	PART NO.	DESCRIPTION
1	6	207644	RIVET
2	1	050175	MAXON PLATE
3	1	263000	EXTENSION PLATE
3A	1	201606	HANDLE
3B	2	201561	STOP BLOCK
3C	1	215342	LEVER, SPRING
3D	1	215341	SAFETY HOOK
4	1	215345	EXTENSION SPRING
5	1	055011	RUBBER HANDLE (GRIP)

**MAXON**<sup>®</sup> 11921 Slauson Ave. Santa Fe Springs, CA. 90670 (800) 227-4116 FAX (888) 771-7713

# LIFT FRAME & PARALLEL ARMS

**MAXON**<sup>®</sup>

11921 Slauson Ave. Santa Fe Springs, CA. 90670 (800) 227-4116 FAX (888) 771-7713

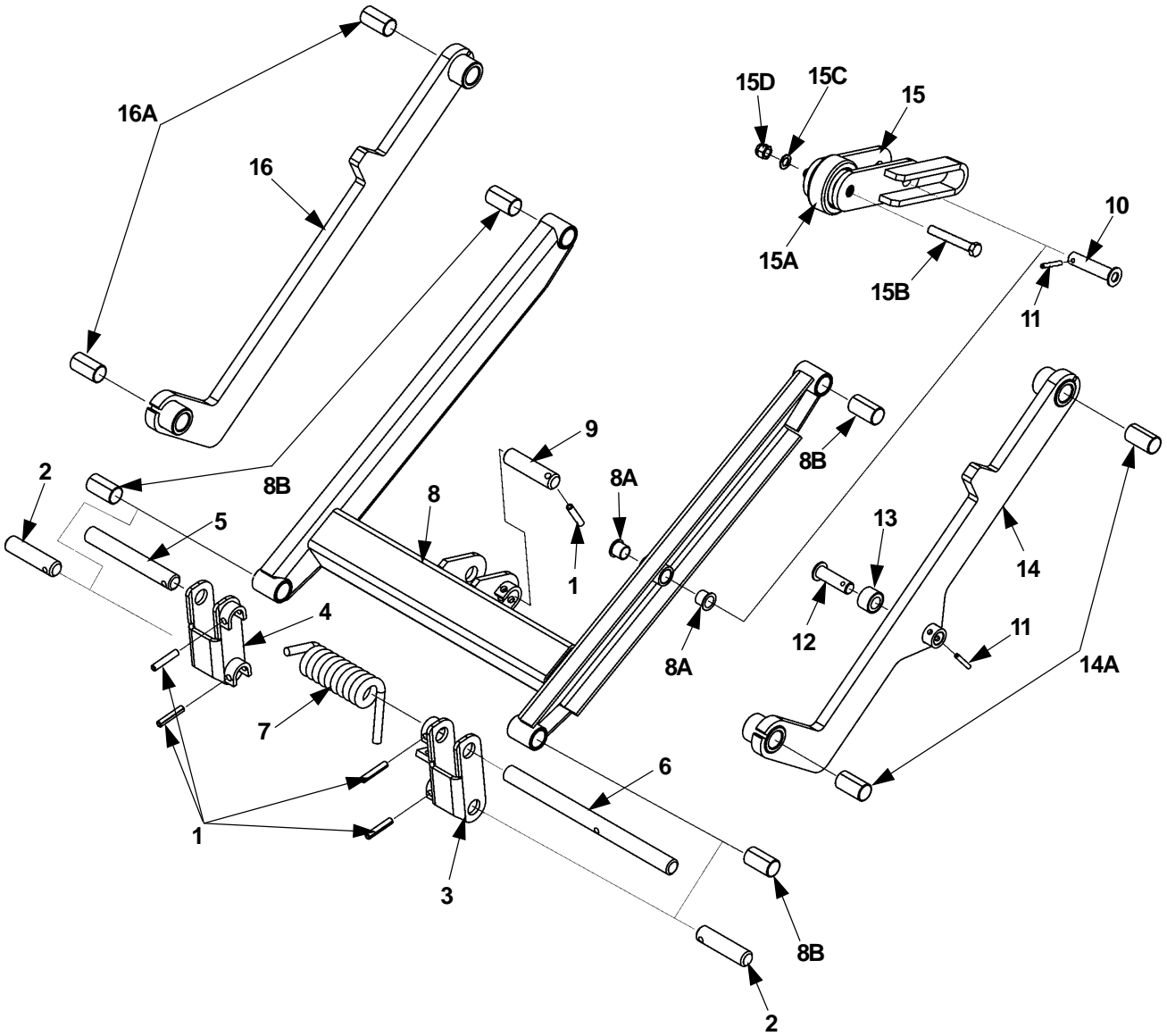

## LIFT FRAME & PARALLEL ARMS

ITEM	QTY.	PART NO.	DESCRIPTION
<b>1</b>	5	221416	ROLL PIN
<b>2</b>	2	252686	PIN, 4" LG.
<b>3</b>	1	280052-01	SHACKLE WELDMENT (RH)
<b>4</b>	1	280052-02	SHACKLE WELDMENT (LH)
<b>5</b>	1	260830	PIN, 7-1/4" LG.
<b>6</b>	1	262981	PIN, 14" LG.
<b>7</b>	1	280849-01	TORSION SPRING
<b>8</b>	1	280050	LIFT FRAME
<b>8A</b>	2	261837-05	BUSHING, FLANGED - PLASTIC
<b>8B</b>	4	260916-03	BEARING, SELF LUBE
<b>9</b>	1	280093	PIN, CYLINDER
<b>10</b>	1	280087-02	PIN WELDMENT
<b>11</b>	2	905033-4	ROLL PIN
<b>12</b>	1	280087-01	PIN WELDMENT
<b>13</b>	1	280085	ROLLER
<b>14</b>	1	280048	PARALLEL ARM RH
<b>14A</b>	2	260916-03	BEARING, SELF LUBE
<b>15</b>	1	280078	OPENER
<b>15A</b>	1	280082-01	ROLLER
<b>15B</b>	1	900035-10	CAP SCREW, 1/2"-13 X 3-1/2" LG.
<b>15C</b>	1	902000-14	FLAT WASHER, 1/2"
<b>15D</b>	1	901010	LOCK NUT, 1/2"-13
<b>16</b>	1	280077	PARALLEL ARM LH
<b>16A</b>	2	260916-03	BEARING, SELF LUBE

**MAXON**<sup>®</sup> 11921 Slauson Ave. Santa Fe Springs, CA. 90670 (800) 227-4116 FAX (888) 771-7713

# PLATFORM & FLIPOVER ASSEMBLY

**MAXON**<sup>®</sup>

11921 Slauson Ave. Santa Fe Springs, CA. 90670 (800) 227-4116 FAX (888) 771-7713

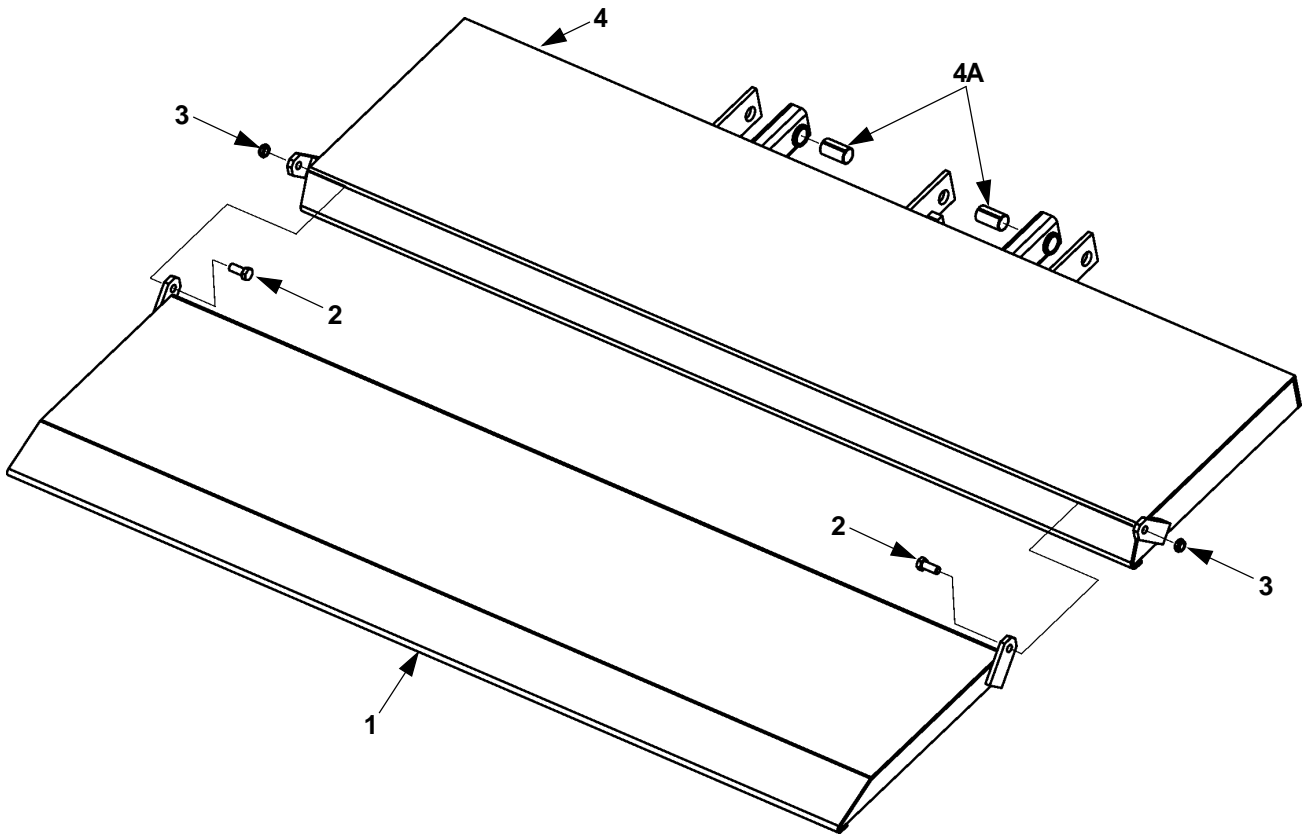

ITEM	QTY.	PART NO.	DESCRIPTION
1	1	280038-01	FLIPOVER (72" WIDE)
	1	280038-02	FLIPOVER (84" WIDE)
2	2	900033-2	CAP SCREW, 1/2"-20 x 1-1/4" LG.
3	2	901016-1	LOCK NUT, THIN HEAD, 1/2"-20
4	1	280043-01	PLATFORM (72" WIDE)
	1	280043-02	PLATFORM (84" WIDE)
4A	2	260916-03	BEARING, SELF LUBE

# PUMP COVER

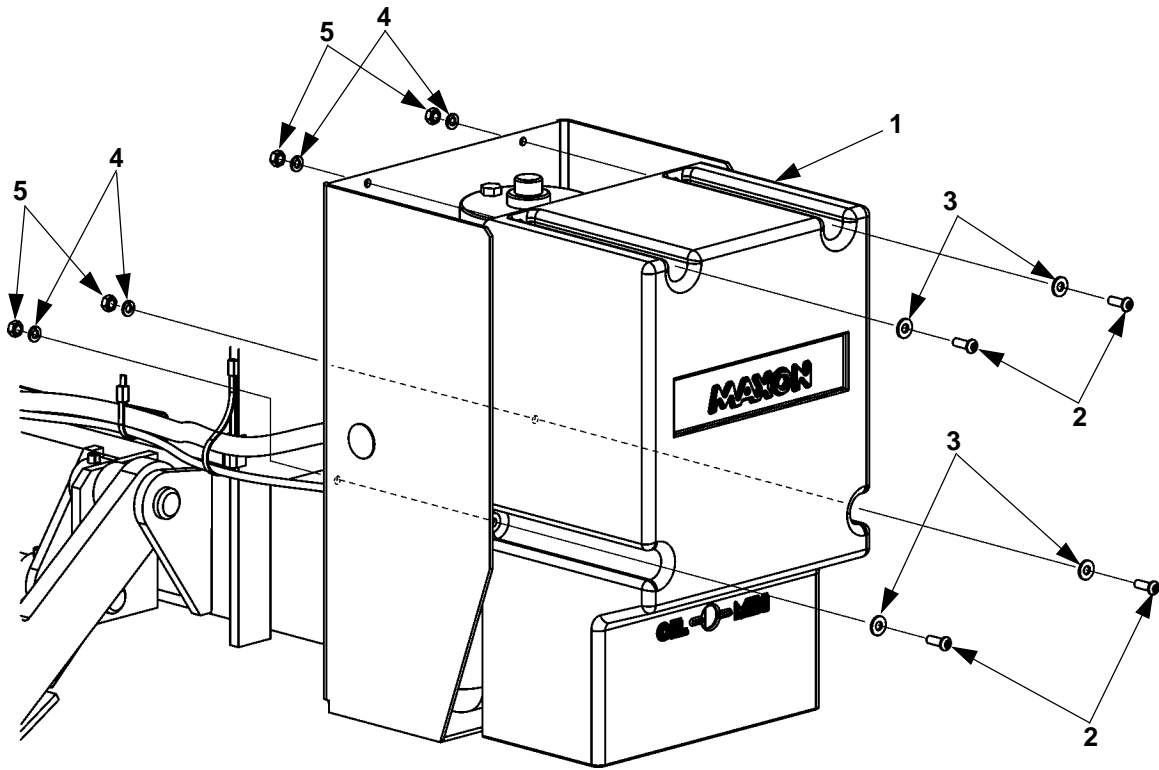

ITEM	QTY.	PART NO.	DESCRIPTION
1	1	280615	PUMP COVER
2	4	900005-3	BUTTON SCREW 1/4"-20 x 3/4" LG.
3	4	902013-09	FLAT WASHER, 1/4"
4	4	902011-2	LOCK WASHER, 1/4"
5	4	901011-1	HEX NUT, 1/4"-20

# GRAVITY DOWN HYDRAULIC COMPONENTS

**MAXON**<sup>®</sup>

11921 Slauson Ave. Santa Fe Springs, CA. 90670 (800) 227-4116 FAX (888) 771-7713

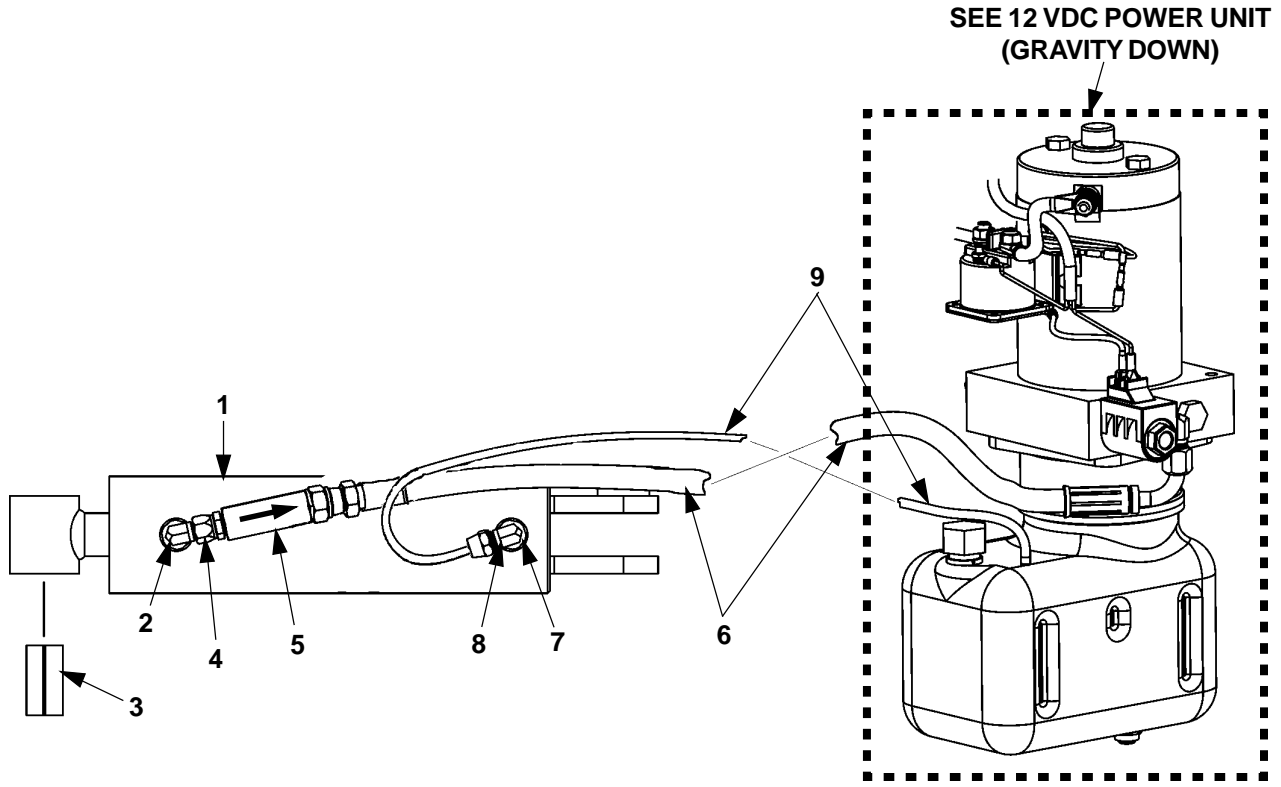

ITEM	QTY.	PART NO.	DESCRIPTION
1	1	280140	CYLINDER (72-150SA)
		280145	CYLINDER (TE-20SA)
2	1	905152	ELBOW 90° SAE #6 - JIC37 #6
3	1	260916-03	BEARING, SELF LUBE
4	1	905181	SWIVEL, O-RING, 3/8" x JIC#6F
5	1	906709-02	FLOW REGULATOR VALVE
6	1	280635-01	HOSE ASSY, 3/8" HP, 60" LG.
7	1	260121	ADAPTER, STRAIGHT THREAD, O-RING #6M - 3/8F
8	1	215406	ELBOW BRASS 1/4" x 3/8"
9	1	224370-07	HOSE, PLASTIC 60-1/2" LG.

# 12 VDC POWER UNIT (GRAVITY DOWN) P/N 280610-01

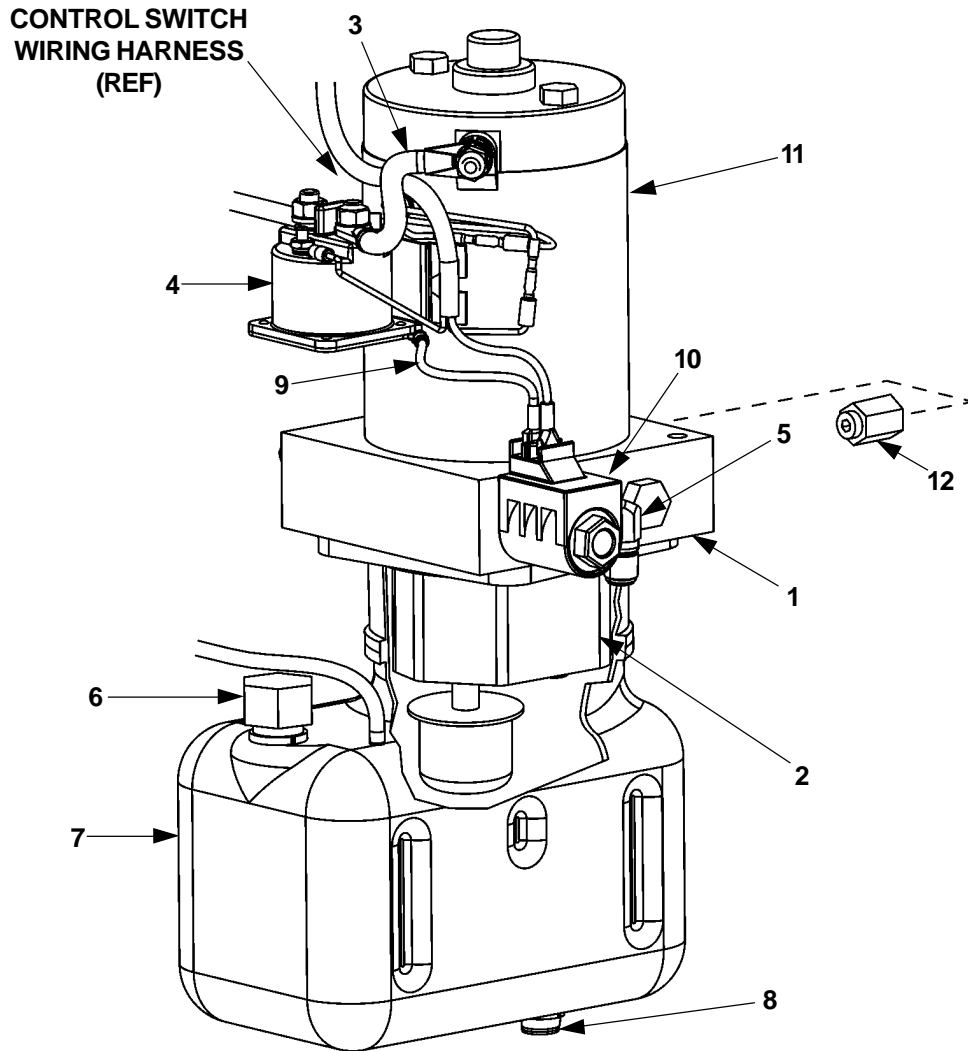

ITEM	QTY.	PART NO.	DESCRIPTION
1	1	280467	PORT PLATE, VERTICAL PUMP MOUNT (GD)
2	1	280466	PUMP, VERTICAL
3	1	280404	CABLE ASSEMBLY
4	1	280394	MOTOR STARTER SOLENOID, 12 VOLTS DC
5	1	906733-01	90° ELBOW
6	1	280806-01	FILLER CAP
7	1	280589-01	RESERVOIR
8	1	908017-01	DRAIN PLUG
9	1	280416	WIRE ASSEMBLY
10	1	280372	SOLENOID VALVE, 12 VOLTS DC
11	1	280374	MOTOR, 12 VOLTS DC
12	1	906737-01	RELIEF VALVE

# POWER DOWN HYDRAULIC COMPONENTS

**MAXON®**

11921 Slauson Ave. Santa Fe Springs, CA. 90670 (800) 227-4116 FAX (888) 771-7713

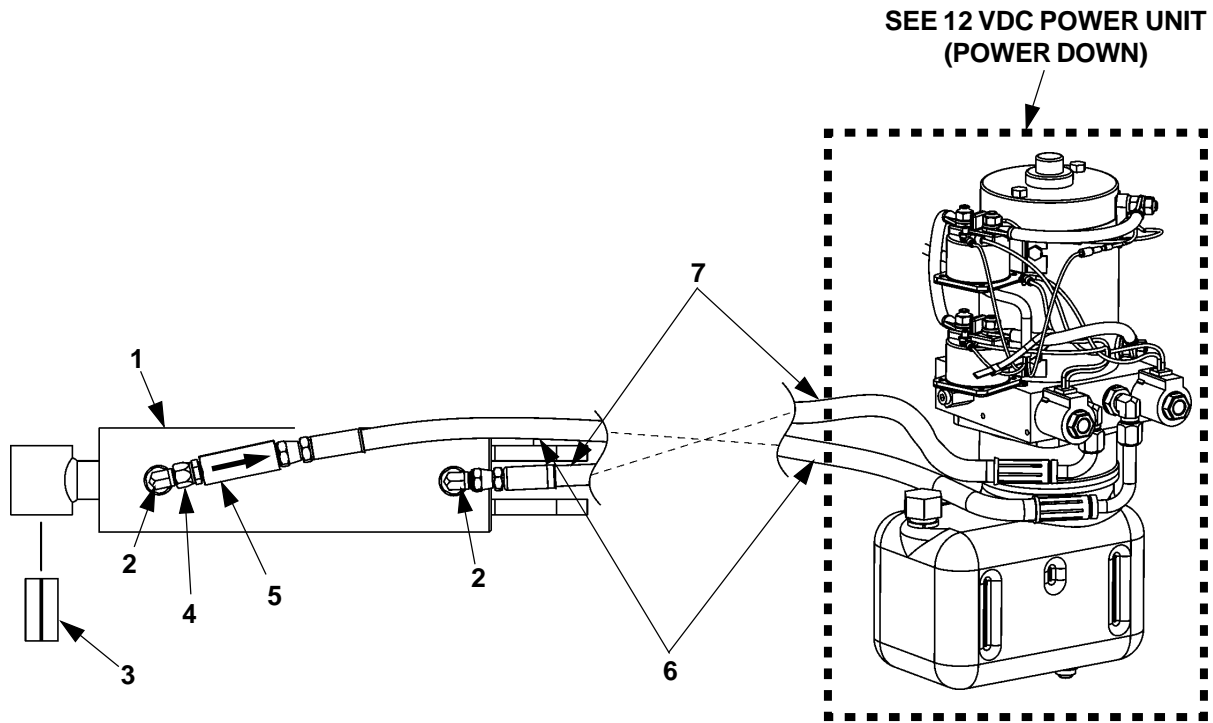

ITEM	QTY.	PART NO.	DESCRIPTION
1	1	280140	CYLINDER (72-150 SA)
		280145	CYLINDER (TE-20 SA)
2	2	905152	ELBOW, 90° SAE #6-JIC37 #6
3	1	260916-03	BEARING, SELF LUBE
4	1	905181	SWIVEL, O-RING, 3/8" M-JIC#6F
5	1	906709-02	FLOW REGULATOR VALVE
6	1	280635-01	HOSE ASSEMBLY, 3/8" HP, 60" LG.
7	1	280634-01	HOSE ASSEMBLY, 3/8" HP, 60" LG.



# 12 VDC POWER UNIT (POWER DOWN) P/N 280600-01

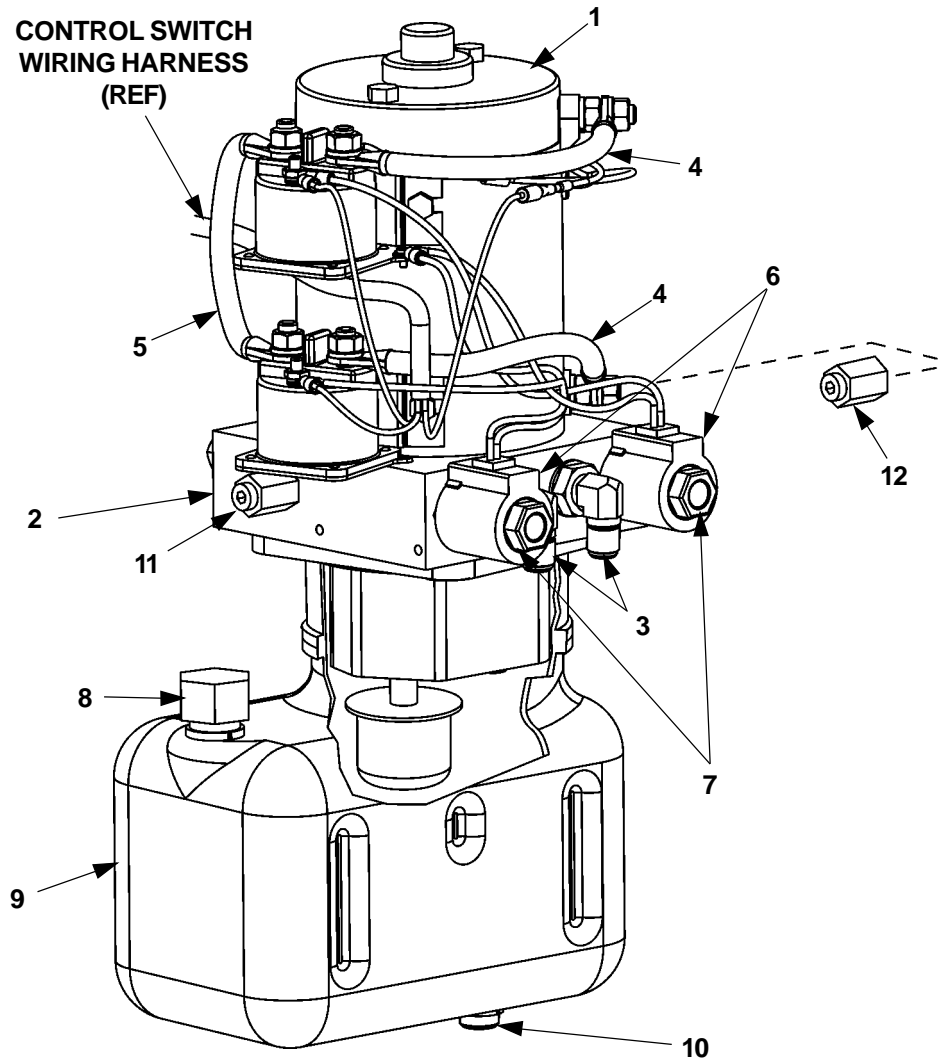

ITEM	QTY.	PART NO.	DESCRIPTION
1	1	280381	MOTOR, 12 VOLTS DC
2	1	290002	3 PIECE GEAR PUMP
3	2	906733-01	ELBOW, 90°
4	2	280404	CABLE ASSEMBLY
5	1	280543	CABLE ASSEMBLY
6	2	906720-01	10 VDC COIL
7	2	906719-01	VALVE
8	1	280806-01	FILLER CAP
9	1	280639-01	RESERVOIR
10	1	908017-01	DRAIN PLUG
11	2	906738-02	RELIEF VALVE HP
12	1	906738-01	RELIEF VALVE LP

# DECALS

**MAXON**<sup>®</sup>

11921 Slauson Ave. Santa Fe Springs, CA. 90670 (800) 227-4116 FAX (888) 771-7713

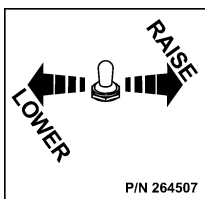
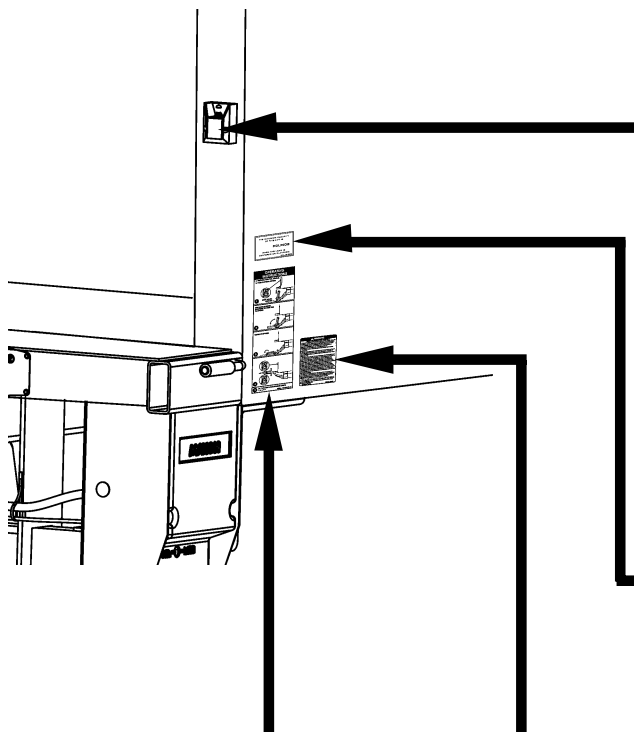

DECAL  
P/N 264507



DECAL  
(LOCATED BY SERIAL PLATE)  
P/N 265642

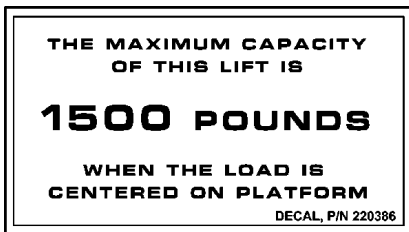

DECAL P/N 220386  
(72-150SA ONLY)

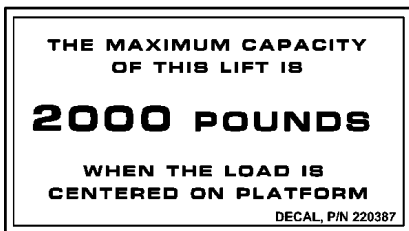

DECAL P/N 220387  
(TE-20SA ONLY)

**OPERATING INSTRUCTIONS**

A. DEPRESS CONTROL HANDLE  
B. PUSH CONTROL SWITCH

**1** MUST TOUCH GROUND

USE HANDLE UNDER PLATFORM TO OPEN THE PLATFORM.

**2**

UNFOLD FLIPOVER.

**3**

**4**

**5** TO TUCK UNIT AWAY REVERSE STEPS 1, 2, 3, & 4. STOW LIFTGATE UNDER HYDRAULIC PRESSURE.

DECAL, P/N 251867-04

DECAL  
P/N 251867-04

**WARNING**

**READ THIS INFORMATION CAREFULLY**

- Improper operation of this Lift can result in serious personal injury. Do not operate unless you have been properly instructed and have read, and are familiar with the operating instructions. If you do not have a copy of the instructions, please obtain them from your employer, distributor, or lessor, before you attempt to operate Lift.
- Be certain that the vehicle is properly and securely braked before using the Lift.
- Always inspect this Lift for maintenance or damage before using it. If there are signs of improper maintenance, damage to vital parts, or slippery Platform surface, do not use the Lift until these problems have been corrected.
- Do not overload the Lift. The load limit is based on evenly distributed cargo over the entire Platform surface. If you are using a pallet jack, be sure it can be maneuvered safely. Do not operate a forklift on the Platform or travel with the platform in an open position at any time.
- Load should be placed in a stable position close to the edge of the Platform nearest the truck. The heaviest portion of the load should never be placed beyond the center of the Platform away from the truck.
- Never allow yourself, a helper, or bystander to stand in a position where a falling load could land on either of you. Also do not allow any part of yours or your helper's body to be placed under, within, or around any portion of the moving liftgate, or its mechanisms, or in a position that would trap them between the platform and the ground or truck when the liftgate is operated.
- If a helper is riding the Platform with you, make sure you are both doing so safely and that you are not in danger of coming in contact with any moving or potentially moving obstacles. USE GOOD COMMON SENSE. If load appears to be unsafe, do not lift or lower it.

Need an Installation Manual or Maintenance Manual? Get a copy from [www.maxonlift.com](http://www.maxonlift.com). If you cannot reach the web site, call Customer Service at (800) 227-4116.

MAXON LIFT CORP. PART NO. 264081

DECAL  
P/N 264081

# CONTROL SWITCH AND POWER CABLE

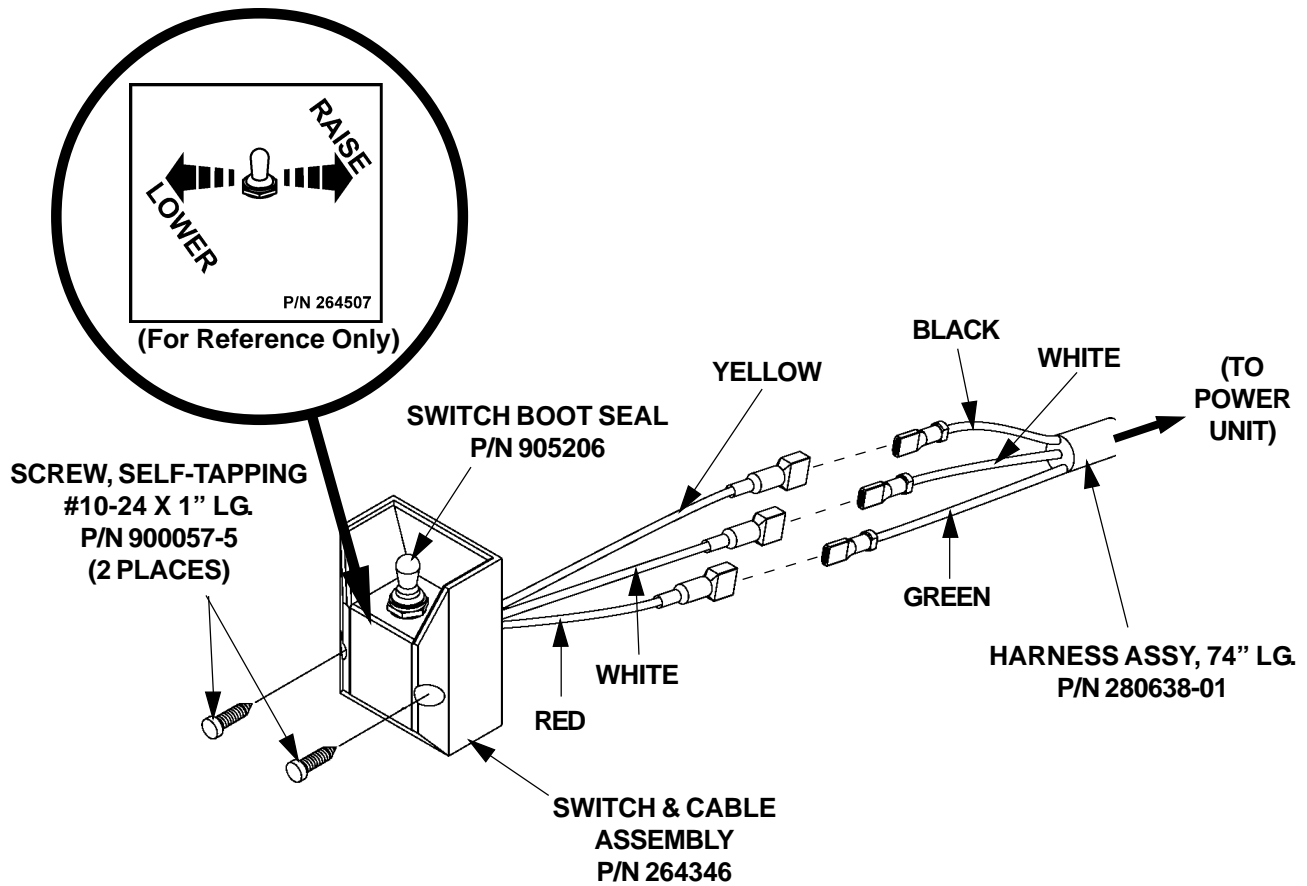

**NOTE:** Use Switch to **RAISE** and **LOWER** Liftgate to make sure Switch operates as shown on the decal.

SHORT END TO  
VEHICLE BATTERY

FUSED BATTERY CABLE ASSY (38' LG.)  
P/N 264422

**⚠ WARNING**  
Do not attach cable to battery until liftgate repairs are completed.

LONG END TO PUMP  
MOTOR SOLENOID

11921 Slauson Ave. Santa Fe Springs, CA. 90670 (800) 227-4116 FAX (888) 771-7713  
**MAXON**

**MAXON®**

11921 Slauson Ave. Santa Fe Springs, CA. 90670 (800) 227-4116 FAX (888) 771-7713

# SCHEMATICS

# HYDRAULIC SCHEMATIC (GRAVITY DOWN) (72-150SA / TE-20SA)

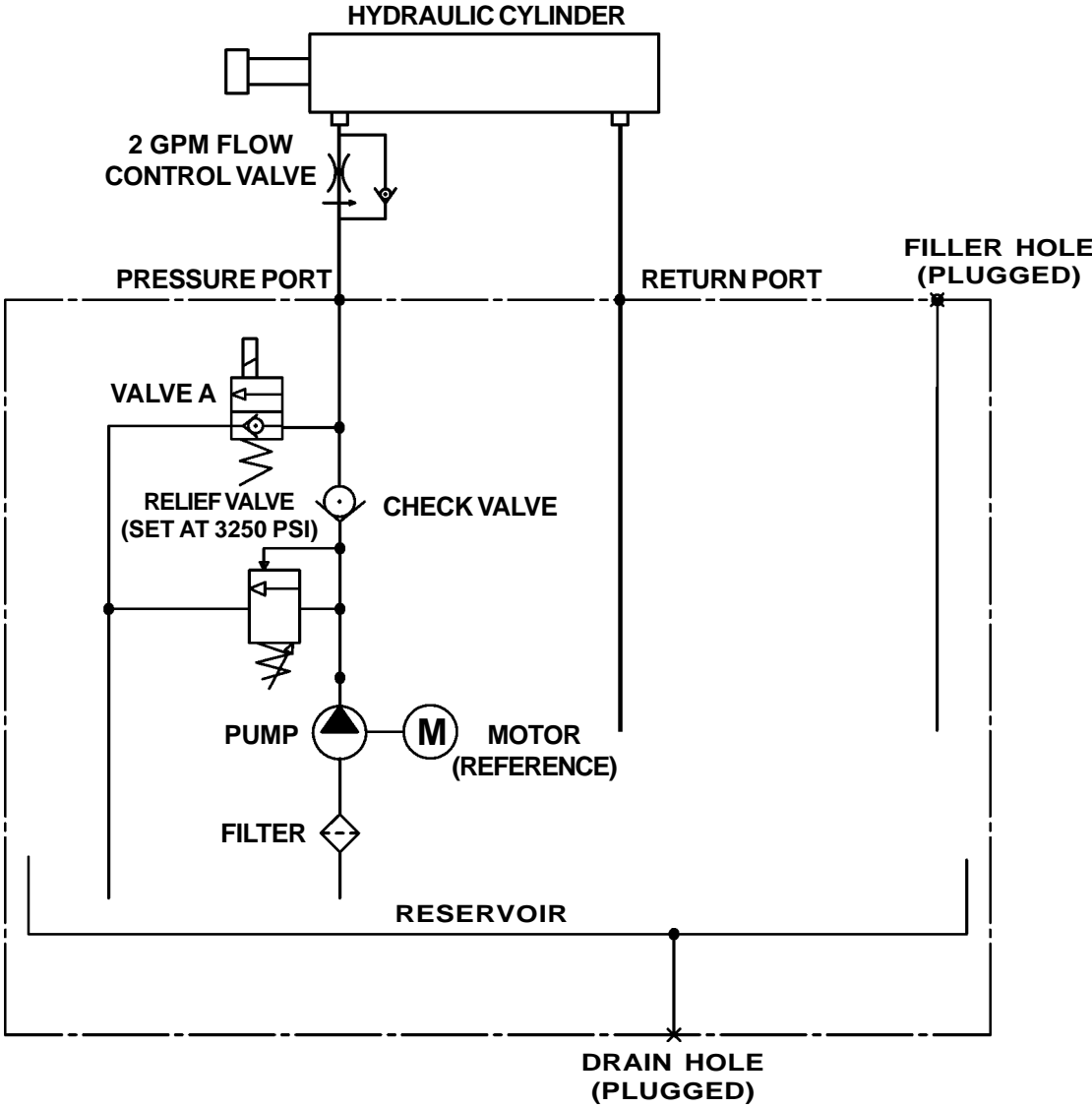

**MAXON**<sup>®</sup> 11921 Slauson Ave. Santa Fe Springs, CA. 90670 (800) 227-4116 FAX (888) 771-7713

# ELECTRICAL SCHEMATIC - GRAVITY DOWN (72-150SA / TE-20SA)

**MAXON**<sup>®</sup>

11921 Slauson Ave. Santa Fe Springs, CA. 90670 (800) 227-4116 FAX (888) 771-7713

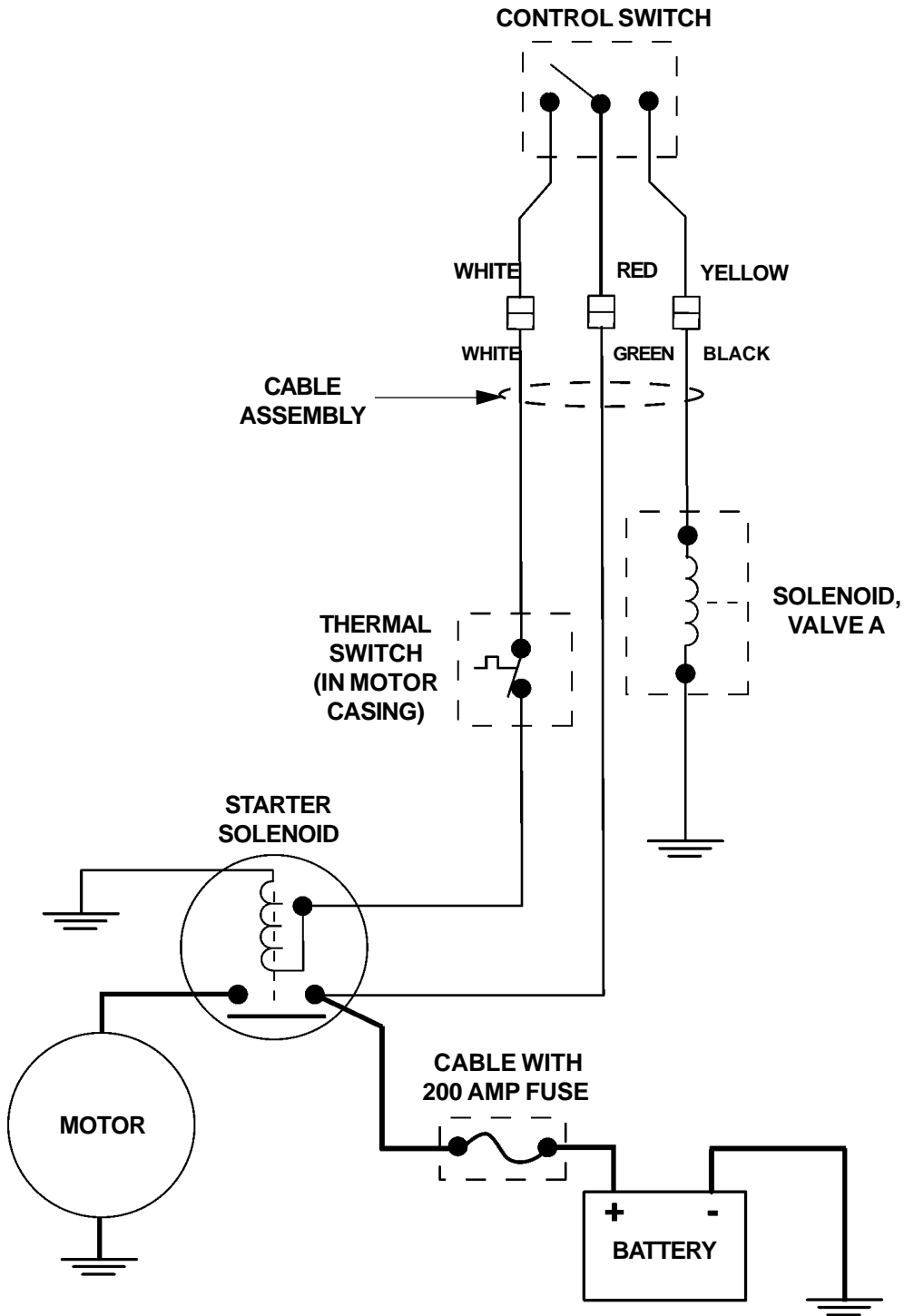

# HYDRAULIC SCHEMATIC - POWER DOWN (72-150SA / TE-20SA)

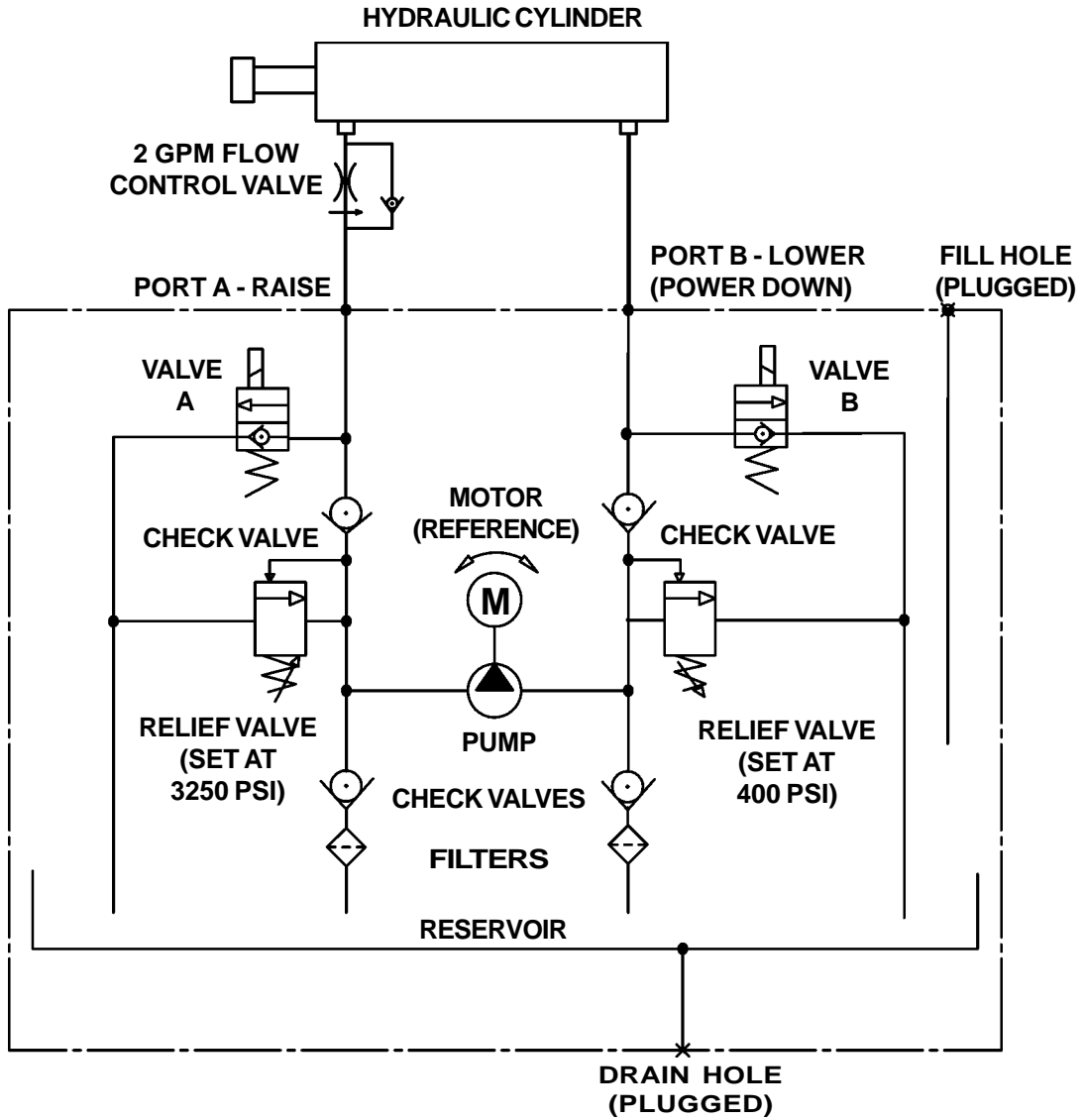

11921 Slauson Ave. Santa Fe Springs, CA. 90670 (800) 227-4116 FAX (888) 771-7713

**MAXON**

# ELECTRICAL SCHEMATIC - POWER DOWN (72-150SA / TE-20SA)

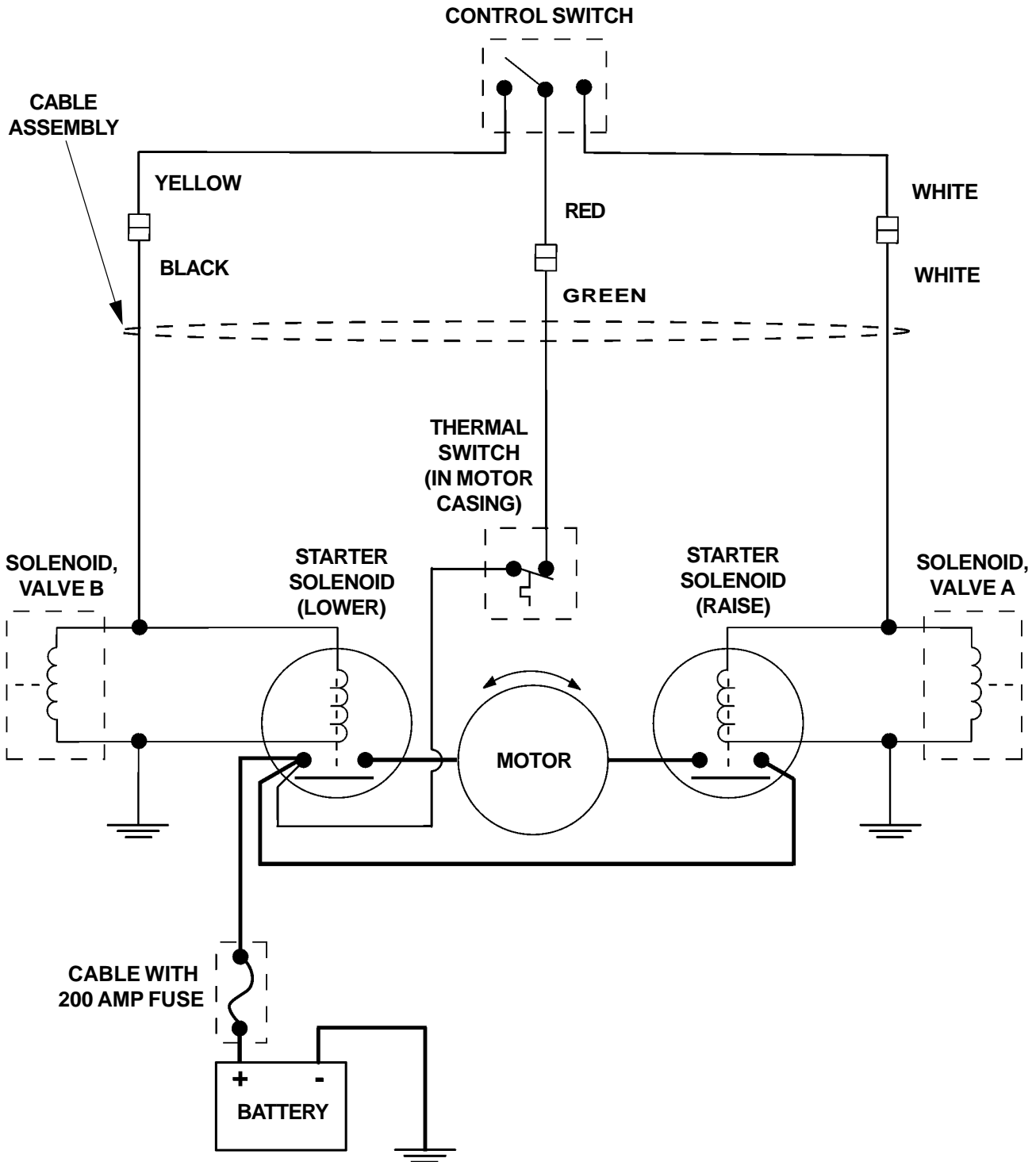

**MAXON**<sup>®</sup>

11921 Slauson Ave. Santa Fe Springs, CA. 90670 (800) 227-4116 FAX (888) 771-7713



# TROUBLESHOOTING

# PLATFORM WILL NOT RAISE

1. Use voltmeter to verify that power is being supplied to Solenoid Terminal "A".  
Recharge the battery if less than 12.6 volts.

## CAUTION

Keep dirt, water and other contaminants from entering the hydraulic system. Before opening the hydraulic fluid reservoir filler cap, drain plug and hydraulic lines, clean up contaminants that can get in the openings. Also, protect the openings from accidental contamination during maintenance.

2. Fill Reservoir to within 1/2" below the top with the hydraulic fluid recommended in the Periodic Maintenance Checklist.
3. Touch a jumper wire to terminals "A" & "C". If motor runs check Switch, switch connections, and White wire. Check and correct wiring connections or replace the Switch.
4. Touch heavy jumper cables to terminals "A" & "B".
  - a. If motor runs, replace the motor solenoid.
  - b. If motor does not run, repair or replace the pump motor.

**NOTE:** In most cases, you can avoid having to bleed the hydraulic system by correctly positioning Liftgate Platform before opening hydraulic lines. Refer to following procedure. Save time on the job and prevent accidental fluid spills and hazards.

5. Check for structural damage and replace worn parts.
6. Check filter in the pump Reservoir. Replace filter if necessary.
7. Check for dirty pump motor relief valve. Clean if necessary.  
Replace any worn out relief valve parts.

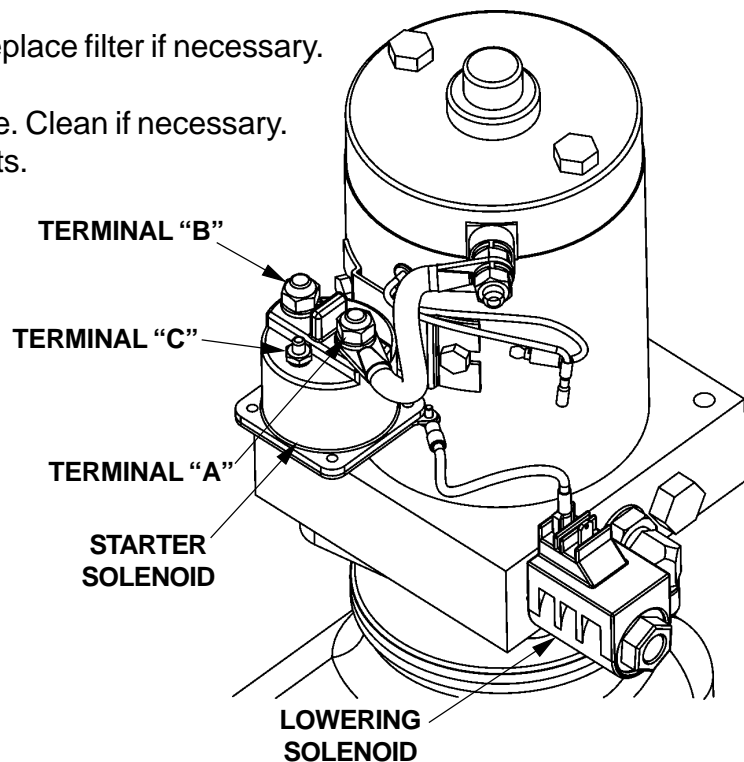

# PLATFORM RAISES BUT LEAKS DOWN

1. Check if Solenoid Valves are constantly energized by touching a screwdriver to the top nut of the Solenoid (**FIG. 1**). Try pulling the screwdriver away from the solenoid. If the solenoid nut attracts the screwdriver (magnetically) without pushing the toggle switch, the control circuit is operating incorrectly. Check if toggle switch, wiring or coil are faulty.

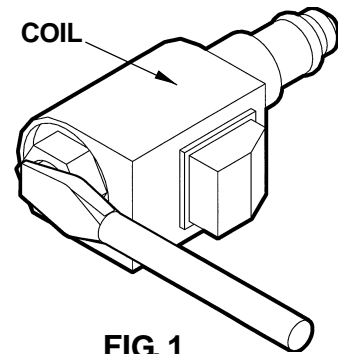

FIG. 1

## CAUTION

Keep dirt, water and other contaminants from entering the hydraulic system. Before opening the hydraulic fluid reservoir filler cap, drain plug and hydraulic lines, clean up contaminants that can get in the openings. Also, protect the openings from accidental contamination during maintenance.

**NOTE:** In most cases, you can avoid having to manually bleed Hydraulic System by correctly positioning Liftgate Platform before disconnecting any Lifting Cylinder high pressure Hydraulic Lines. The following procedure can save time and prevent accidental fluid spills and hazards.

2. Check the Valve Stem by removing the Coil Assembly (**Item 1, FIG. 2**). With platform on ground, unscrew the Valve Stem, (**Item 2, FIG. 2**) from the Pump. Push on the plunger that is located inside the Valve Stem by inserting a small screwdriver blade in the end. If the Plunger does not move freely (approximately 1/8") replace the Valve Stem. **When re-installing valve stem, torque hex nut to 30 in-lbs.**
3. Check the Hydraulic Cylinder. With the Platform on the ground, remove the hydraulic line from the Down Port of the Cylinder (**FIG. 3**). Raise the Platform even with the bed. Allow pump motor to run two seconds more while you watch for hydraulic fluid at the Down Port. A few drops of hydraulic fluid escaping the Down Port is normal; however, if it streams from the Down Port, Piston Seals are worn. Replace Seals.

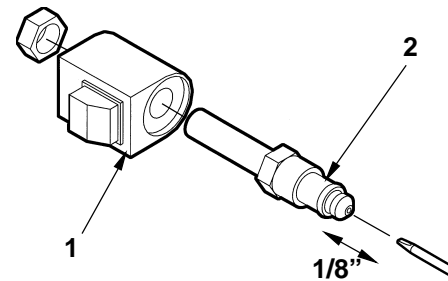

FIG. 2

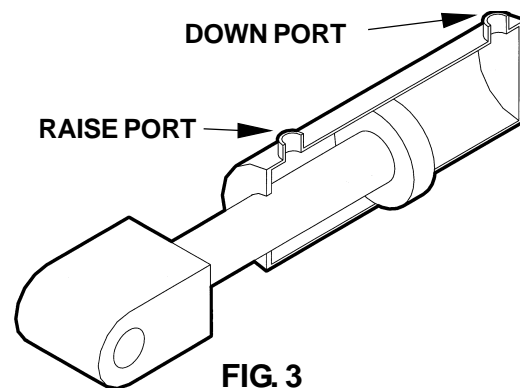

FIG. 3

# PLATFORM RAISES PARTIALLY AND STOPS

## CAUTION

Keep dirt, water and other contaminants from entering the hydraulic system. Before opening the hydraulic fluid reservoir filler cap, drain plug and hydraulic lines, clean up contaminants that can get in the openings. Also, protect the openings from accidental contamination during maintenance.

1. Lower the opened Platform to the ground. Fill the Pump Reservoir on Gravity-Down Liftgates to within 1/2" below the top with hydraulic fluid recommended in Periodic Maintenance Checklist.
2. Use voltmeter to verify that the Battery shows 12.6 volts or more.
3. Check for Structural damage, or poor lubrication. Replace worn parts.

**NOTE:** In most cases, you can avoid having to bleed the hydraulic system by correctly positioning Liftgate Platform before opening hydraulic lines. Refer to following procedure. Save time on the job and prevent accidental fluid spills and hazards.

4. Check the Hydraulic Cylinder. With the Platform on the ground, remove the Breather Plug or Vent Line from the Vent Port of the Cylinder (**FIG. 3**). Raise the Platform even with the bed. Allow pump motor to run two seconds more while you watch for hydraulic fluid at the Vent Port. A few drops of hydraulic fluid escaping the Vent Port is normal; however, if it streams from the Vent Port, Piston Seals are worn. Replace Seals.
5. Check Filter in the Pump Reservoir. Replace filter if necessary.
6. Check for dirty pump motor relief valve. Clean if necessary. Replace any worn out relief valve parts.

**MAXON**<sup>®</sup>

11921 Slauson Ave. Santa Fe Springs, CA. 90670 (800) 227-4116 FAX (888) 771-7713

# LIFTGATE WILL NOT LIFT RATED CAPACITY

1. Use voltmeter to verify that the Battery shows 12.6 volts or more under load from pump motor.
2. Check for Structural damage or lack of lubrication. Replace worn parts.

## CAUTION

Keep dirt, water and other contaminants from entering the hydraulic system. Before opening the hydraulic fluid reservoir filler cap, drain plug and hydraulic lines, clean up contaminants that can get in the openings. Also, protect the openings from accidental contamination during maintenance.

**NOTE:** In most cases, you can avoid having to bleed the hydraulic system by correctly positioning Liftgate Platform before opening hydraulic lines. Refer to following procedure. Save time on the job and prevent accidental fluid spills and hazards.

3. With Platform on the ground, remove the pressure hose and fitting from the Pump and replace it with a 0-3000 PSI Pressure Gauge. Hold the switch in the "UP" position. Adjust the Relief Valve on the side of the Pump until the gauge shows 2800 to 3000 PSI (**FIG. 5**). Remove gauge and re-install pressure hose.
4. Check for dirty pump motor relief valve. Clean if necessary. Replace any worn out relief valve parts.
5. Check the Hydraulic Cylinder. With the Platform on the ground, remove the Breather Plug or Vent Line from the Vent Port of the Cylinder (**FIG. 4**). Raise the Platform even with the bed. Allow pump motor to run two seconds more while you watch for hydraulic fluid at the Vent Port. A few drops of hydraulic fluid escaping the Vent Port is normal; however, if it streams from the Vent Port, Piston Seals are worn. Replace Seals.
6. If Pump cannot produce 2800-3000 PSI with a minimum of 12.6 Volts available, the Pump is worn and needs to be replaced.

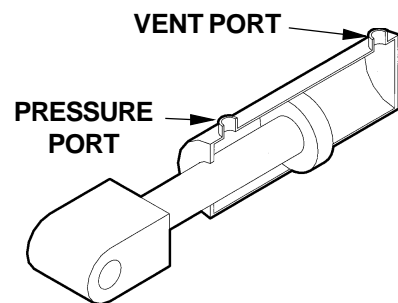

FIG. 4

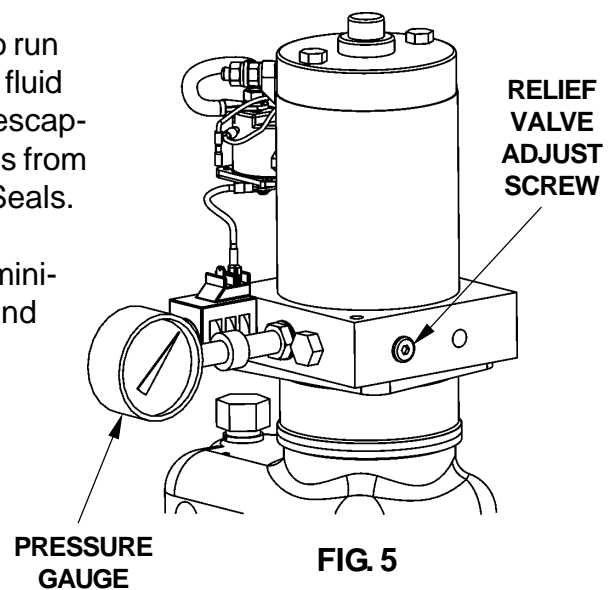

FIG. 5

# PLATFORM RAISES SLOWLY

1. Use voltmeter to verify that power is being supplied to Solenoid Terminal "A". Recharge the battery if voltmeter indicates less than 12.6 Volts ( **FIG. 6** ).

## CAUTION

Keep dirt, water and other contaminants from entering the hydraulic system. Before opening the hydraulic fluid reservoir filler cap, drain plug and hydraulic lines, clean up contaminants that can get in the openings. Also, protect the openings from accidental contamination during maintenance.

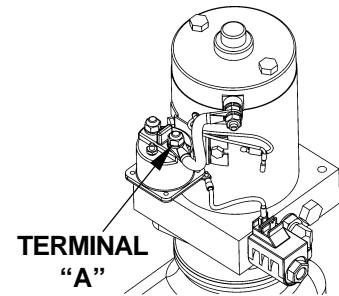

**FIG. 6**

2. Check the Hydraulic Cylinder. With the Platform on the ground, remove the Breather Plug or Vent Line from the Vent Port of the Cylinder ( **FIG. 8** ). Raise the Platform even with the bed. Allow pump motor to run two seconds more while you watch for hydraulic fluid at the Vent Port. A few drops of hydraulic fluid escaping the Vent Port is normal; however, if it streams from the Vent Port, Piston Seals are worn. Replace Seals.

**NOTE:** In most cases, you can avoid having to bleed the hydraulic system by correctly positioning Liftgate Platform before opening hydraulic lines. Refer to following procedure. Save time on the job and prevent accidental fluid spills and hazards.

3. Check and clean Flow Control Valve in high pressure hydraulic line attached to Cylinder. When installing Flow Control Valve make sure arrow on valve is oriented as shown in ( **FIG. 8** ).
4. Lower the opened Platform to the ground. Fill the Pump Reservoir on Gravity-Down Liftgates to within 1/2" below the top with hydraulic fluid recommended in Periodic Maintenance Checklist.

5. Verify the Pump Motor is grounded to the vehicle frame.
6. Check for leaking hoses and fittings. Tighten or replace as required.
7. Check for structural damage or poor lubrication. Replace worn parts.
8. Check the Filter in the Pump Reservoir. Replace if necessary.

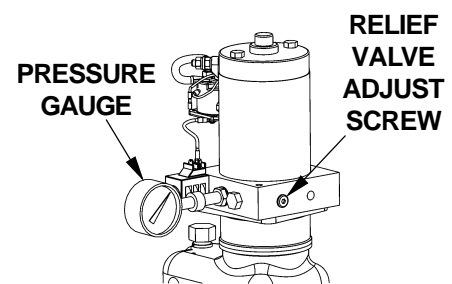

**FIG. 7**

9. With Platform on the ground, remove the pressure hose and fitting from the Pump and replace it with a 0-3000 PSI Pressure Gauge. Hold the Control switch in the "RAISE" position. Adjust the Relief Valve on the side of the Pump until the gauge shows 2800 to 3000 PSI ( **FIG. 7** ). Remove gauge and re-install pressure hose.

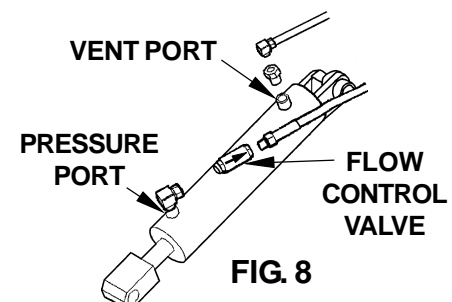

**FIG. 8**

# PLATFORM WILL NOT LOWER, LOWERS TOO SLOWLY, OR LOWERS TOO QUICKLY

1. Use voltmeter to verify that power is being supplied to Solenoid Terminal "A". Recharge the battery if voltmeter indicates less than 12.6 Volts ( FIG. 9).
2. Check for structural damage or poor lubrication. Replace worn parts.
3. Check if Solenoid Valve is getting power by holding a screwdriver against the top nut of the Solenoid. Push Control Switch to "LOWER" position to energize solenoid (FIG. 10). A good solenoid will attract (magnetically) the screwdriver to the nut and make it difficult to pull the screwdriver away from the nut.

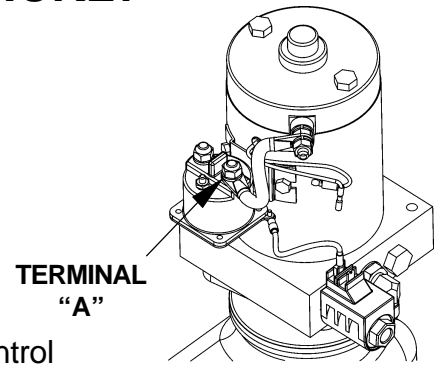

FIG. 9

## CAUTION

Keep dirt, water and other contaminants from entering the hydraulic system. Before opening the hydraulic fluid reservoir filler cap, drain plug and hydraulic lines, clean up contaminants that can get in the openings. Also, protect the openings from accidental contamination during maintenance.

**NOTE:** In most cases, you can avoid having to bleed the hydraulic system by correctly positioning Liftgate Platform before opening hydraulic lines. Refer to following procedure. Save time on the job and prevent accidental fluid spills and hazards.

4. Check the Valve Stem by removing the Coil Assembly (Item 1, FIG. 10). With platform supported, unscrew the Valve Stem (Item 2, FIG. 10) from the Pump. Push on the plunger located inside the Valve Stem by inserting a small screwdriver blade in the end. If the Plunger does not move freely (approximately 1/8") replace the Valve Stem.
5. Check if filtering screen on solenoid valve is plugged. Clean carefully if required.
6. Check and clean Flow Control Valve in high pressure hydraulic line attached to Cylinder.
7. Check if Flow Control Valve (FIG. 11) is pointing to the direction of restricted fluid flow (back toward pump). If required, remove Flow Control Valve and install it correctly (FIG. 11).

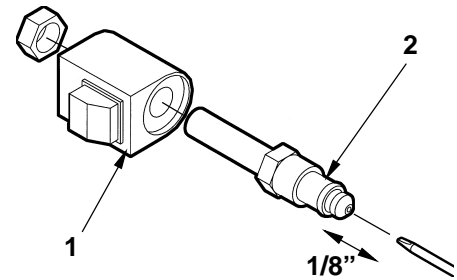

FIG. 10

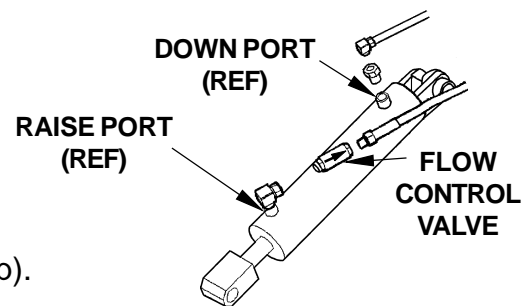

FIG. 11