



MAXON[®] GPT-Series

OPERATION MANUAL GPT-25, GPT-3, GPT-4, GPT-5, & GPTWR-3



© MAXON Lift Corp. 2010

KEEP THIS MANUAL IN CAB OF VEHICLE

Register your liftgate on line at www.maxonlift.com/html/services/reg.htm.

For a free copy of other manuals that pertain to these liftgate models, please visit our website at www.maxonlift.com or call Customer Service at (800) 227-4116.

TABLE OF CONTENTS

LIFTGATE TERMINOLOGY	5
RECOMMENDED DAILY OPERATION CHECKS.....	6
DECALS (GPT MODELS)	8
DECALS (GPTWR-3).....	10
FORKLIFT ADVISORY	12
ROADSIDE OPERATION ADVISORY	13
OPERATION	14
USING CART STOPS (IF EQUIPPED)	22

WARNING

1. Incorrect operation of this Liftgate can result in serious personal injury. Comply with **WARNINGS** and Liftgate operating instructions in this manual. Do not allow untrained persons or children to operate the Liftgate. If you need to replace an **Operation Manual**, additional copies are available from:

MAXON Lift Corp.
11921 Slauson Ave
Santa Fe Springs, CA 90670
(800) 227-4116

NOTE: For latest version manuals (and replacements), download manuals from Maxon's website at **www.maxonlift.com**.

2. Do not exceed rated load capacity of the Liftgates, which is **2500 lbs. for the GPT-25, 3000 lbs. for the GPT-3 and GPTWR-3, 4000 lbs. for the GPT-4, and 5000 lbs. for the GPT-5.**
3. Do not allow any part of your body to be placed under, within, or around any portion of the moving Liftgate or its mechanisms, or in a position that would trap them between the platform and the floor of truck body (or between platform and the ground) when Liftgate is operating.
4. Consider the safety and location of bystanders and location of nearby objects when operating the Liftgate. Stand to one side of platform while operating the Liftgate. Be certain that the area the Liftgate will move through during operation is clear of all obstacles.
5. Comply with all attached instruction decals and warning decals.
6. Keep decals clean and legible. If decals are illegible or missing, have them replaced. **Get free replacement decals from Maxon.**
7. **Never drive a forklift on the Liftgate platform.**
8. Do not move vehicle unless Liftgate is correctly stowed.
9. **Correctly stow platform when not in use. Extended platforms could create a hazard for people and vehicles passing by.**
10. A correctly installed Liftgate will operate smoothly and reasonably quiet. The only noticeable noise, during Liftgate operation, is from the power unit while the platform is raised. Listen for scraping, grating and binding noises and have the problem corrected before continuing to operate the Liftgate.
11. Above all, **USE GOOD COMMON SENSE** when operating the Liftgate.
12. Never use a cell phone while operating the Liftgate.

LIFTGATE TERMINOLOGY

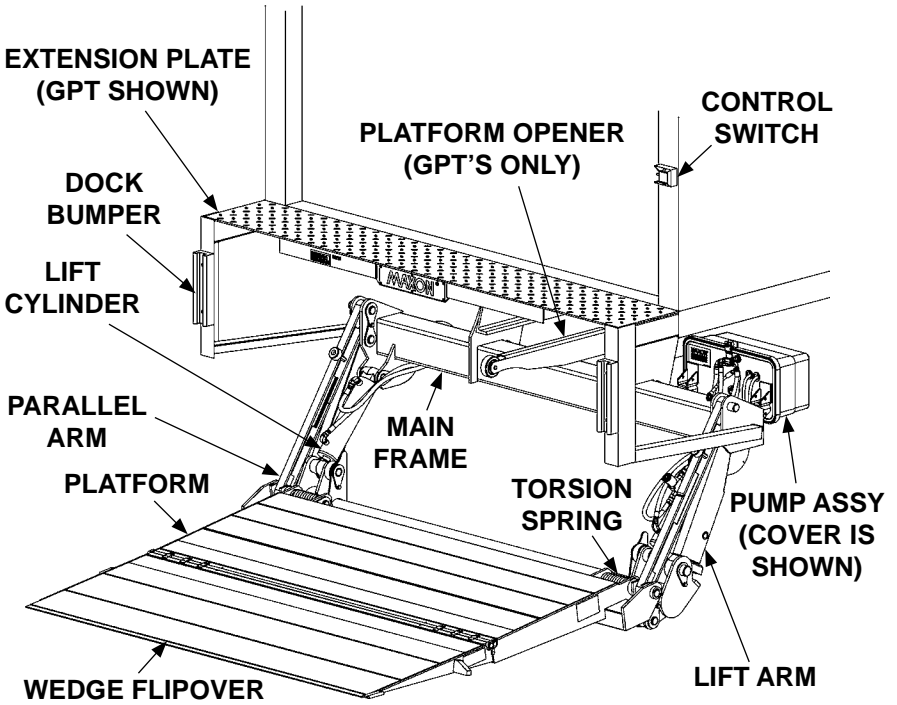

RECOMMENDED DAILY OPERATION CHECKS

NOTE: Before you check the Liftgate, park vehicle on flat ground and set the parking brake.

NOTE: If any of the following operation checks reveal a need to service or repair Liftgate, do not operate the Liftgate until a qualified mechanic services or repairs the Liftgate.

Before operating the Liftgate, the operator should do the following:

- Make sure battery is fully charged and battery terminal connections are clean and tight.
- Make sure cab cutoff switch is **ON**, if equipped.
- Visually check that pump cover is bolted on securely and undamaged. Look for hydraulic fluid leaking from the pump box.
- Visually check that control switch is in place and undamaged.
- Visually check for cracks and bends on the extension plate. Also, make sure fasteners are in place and undamaged and extension plate is clean (no oil, debris, or corrosion).
- Visually check that all decals are in place (see **DECALS** page). Make sure decals are legible, clean, and undamaged.

Use the operation instructions in this manual to lower the Liftgate to the ground and open the platform and flipover.

- Check main frame, lift arms, parallel arms and platform openers for cracks and bends. Make sure rollers, on the platform openers, roll freely. Also, make sure all bolts and pins are in place and undamaged.
- Make sure main frame, lift arms, parallel arms and platform openers are clean (no oil, debris, or corrosion).
- Check the hydraulic cylinders for leaking seals and hose connections. Follow the hydraulic hoses (or return lines for gravity down Liftgates) from the cylinders to pump box. Make sure all hoses are connected at both ends and there are no cracks, chafing, and fluid leaks.

- With the platform unfolded and raised to bed level, check if the outboard edge of platform is level or rises up to 1" above bed level (**YES illustration**). If the outboard edge of platform looks like the **YES illustration**, you can operate Liftgate. If the outboard edge of platform is below level line and platform looks like the **NO illustration**, do not operate the Liftgate. (See **NOTE** at beginning of the **DAILY OPERATION CHECKS**.)

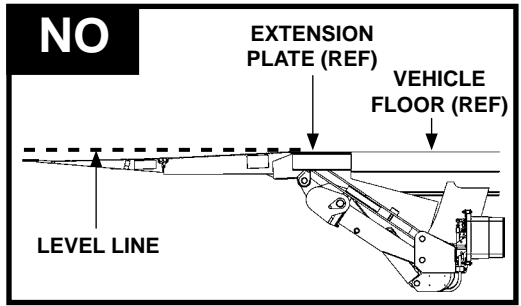
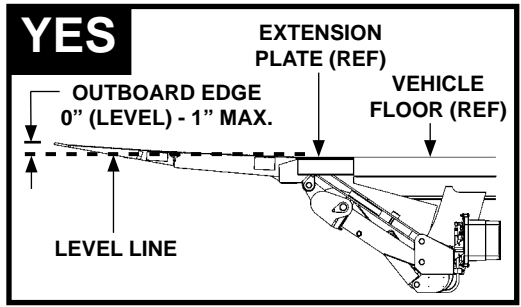

- Check the platform and flipover for cracks, holes, and bends on the load-carrying surface and side plates. Also, make sure torsion bars, coil springs, and fasteners are in place and undamaged.
- Make sure platform and flipover load-carrying surfaces are clean (no oil, debris, or corrosion).

Use the operation instructions in this manual to operate the Liftgate through one cycle without a load on the platform. Raise the platform to vehicle bed height. Next, lower the platform to ground level.

- When the Liftgate is moving, listen for unusual noises and look for a “jerking” motion or uneven movement on either side of the platform.

If service or repairs are not required (or if completed), stow the Liftgate.

DECALS (GPT MODELS)



DECAL "H" (2 PLACES)



PAINT DECAL
P/N 267338-01

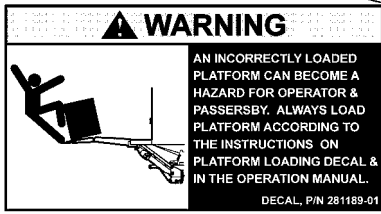

PLATFORM WARNING DECAL
(2 PLACES)
P/N 281189-01

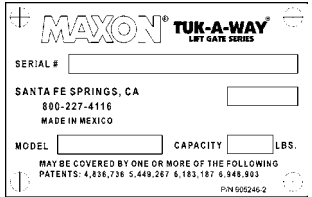
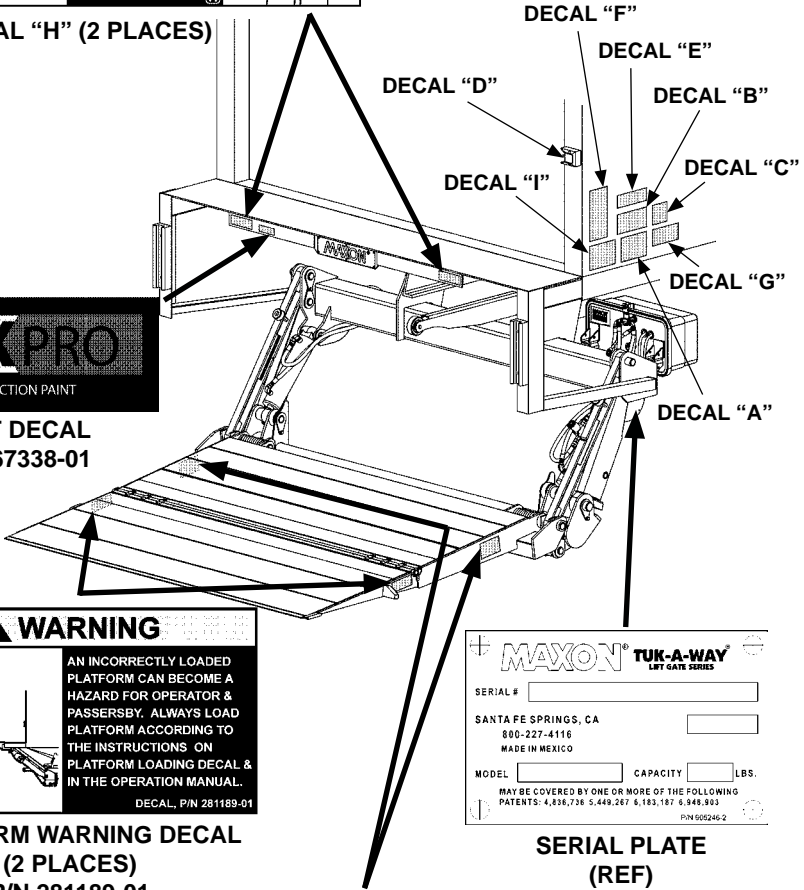

SERIAL PLATE
(REF)

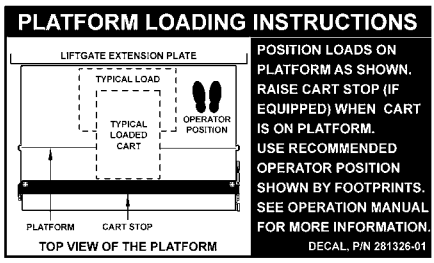

PLATFORM LOADING DECAL
(2 PLACES)
P/N 281326-01

SAFETY INSTRUCTIONS

Read all decals and operation manual before operating liftgate.

1. Do not use liftgate unless you have been properly instructed and have read, and are familiar with, the operating instructions.
2. Be certain vehicle is properly and securely braked before using the liftgate.
3. Always inspect this liftgate for maintenance or damage before using it. Do not use liftgate if it shows any sign of damage or improper maintenance.
4. Do not overload.
5. Make certain the area in which the platform will open and close is clear before opening or closing the platform.
6. Make certain platform area, including the area in which loads may fall from platform, is clear before and at all times during operation of liftgate.
7. This liftgate is intended for loading and unloading of cargo only. Do not use this liftgate for anything but its intended use.

(A)

WARNING

Read this information carefully.

- Improper operation of this Liftgate can result in serious personal injury. If you do not have a copy of the operating instructions, please obtain them from your employer, distributor, or lessor before you attempt to operate Liftgate.
- If there are signs of improper maintenance, damage to vital parts, or slippery platform surface, do not use the Liftgate until these problems have been corrected.
- If you are using a pallet jack, be sure it can be maneuvered safely.
- Do not operate a forklift on the platform.
- Do not allow any part of yours or your helper's body to be placed under, within, or around any portion of the moving Liftgate, or its mechanisms, or in a position that would trap them between the platform and the ground or truck when the Liftgate is operated.
- If a helper is riding the platform with you, make sure you are both doing so safely and that you are not in danger of coming in contact with any moving or potentially moving obstacles.
- **USE GOOD COMMON SENSE.**
- If load appears to be unsafe, do not lift or lower it.

For a free copy of other manuals that pertain to this model Liftgate, please visit our website at www.maxonlift.com or call Customer Service at (800) 227-4118.

(C)

CAUTION

Always stand clear of platform area.

(E)

THE MAXIMUM CAPACITY
OF THIS LIFT IS
POUNDS
WHEN THE LOAD IS
CENTERED ON THE LOAD
CARRYING PLATFORM

(B)

(See TABLE 9-1)



WARNING

Liftgate hazards can result in crushing or falling.

Keep hands and feet clear of pinch points.

If riding liftgate, make sure load is stable and footing is solid.

(G)

Read and understand all instructions and WARNINGS before use.



(D)

OPERATING INSTRUCTIONS

GPT Series Liftgates

1. Push control switch. (Must touch the ground)
2. Unfold platform. (Must touch the ground)
3. Unfold flipover. (Must touch the ground)
4. Use switch to raise or lower. (Must touch the ground)
5. To tuck liftgate away, reverse steps 1, 2, & 3. (Must touch the ground)

(F)

DECAL SHEET
FIG. 9-1

MODEL	DECAL SHEET P/N	DECAL "B"
GPT-25	282848-01	2500 POUNDS
GPT-3	282848-02	3000 POUNDS
GPT-4	282848-03	4000 POUNDS
GPT-5	282848-04	5000 POUNDS

DECAL SHEET
TABLE 9-1

DECALS (GPTWR-3)



PAINT DECAL
P/N 267338-01

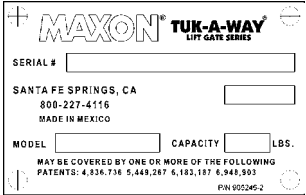
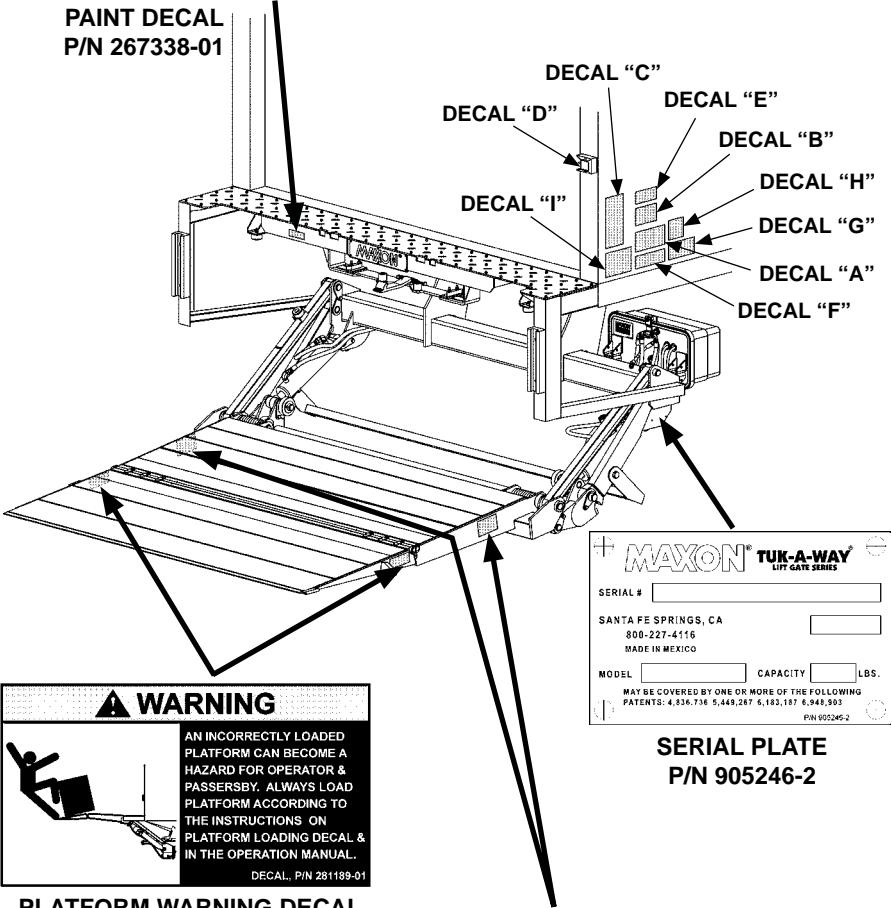

SERIAL PLATE
P/N 905246-2

WARNING

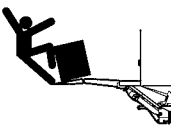

AN INCORRECTLY LOADED PLATFORM CAN BECOME A HAZARD FOR OPERATOR & PASSERSBY. ALWAYS LOAD PLATFORM ACCORDING TO THE INSTRUCTIONS ON PLATFORM LOADING DECAL & IN THE OPERATION MANUAL.

DECAL, P/N 281189-01

PLATFORM WARNING DECAL
(2 PLACES)
P/N 281189-01

PLATFORM LOADING INSTRUCTIONS

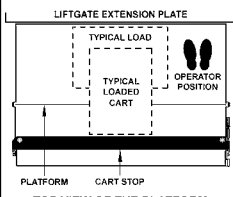

LIFTGATE EXTENSION PLATE

TYPICAL LOAD

TYPICAL LOADED CART

OPERATOR POSITION

PLATFORM CART STOP

TOP VIEW OF THE PLATFORM

POSITION LOADS ON PLATFORM AS SHOWN. RAISE CART STOP (IF EQUIPPED) WHEN CART IS ON PLATFORM. USE RECOMMENDED OPERATOR POSITION SHOWN BY FOOTPRINTS. SEE OPERATION MANUAL FOR MORE INFORMATION.

DECAL, P/N 281326-01

PLATFORM LOADING DECAL
(2 PLACES)
P/N 281326-01

SAFETY INSTRUCTIONS

Read all decals and operation manual before operating liftgate.

- Do not use liftgate unless you have been properly instructed and have read, and are familiar with, the operating instructions.
- Be certain vehicle is properly and securely braked before using the liftgate.
- Always inspect this liftgate for maintenance or damage before using it. Do not use liftgate if it shows any sign of damage or improper maintenance.
- Do not overload.
- Make certain the area in which the platform will open and close is clear before opening or closing the platform.
- Make certain platform area, including the area in which loads may fall from platform, is clear before and at all times during operation of liftgate.
- This liftgate is intended for loading and unloading of cargo only. Do not use this liftgate for anything but its intended use.

(A)

SAFETY INSTRUCTIONS

- Read WARNING decal for the walk ramp before you set up walk ramp & stow walk ramp.
- To set up walk ramp & stow walk ramp, refer to walk ramp manufacturer's instructions.

PIN 268454-01 (F)

WARNING

Read this information carefully.

- Improper operation of this Liftgate can result in serious personal injury. If you do not have a copy of the operating instructions, please obtain them from your employer, distributor, or lessor before you attempt to operate Liftgate.
- If there are signs of improper maintenance, damage to vital parts, or slippery platform surface, do not use the Liftgate until these problems have been corrected.
- If you are using a pallet jack, be sure it can be maneuvered safely.
- Do not operate a forklift on the platform.
- Do not allow any part of yours or your helper's body to be placed under, within, or around any portion of the moving Liftgate, or its mechanisms, or in a position that would trap them between the platform and the ground or truck when the Liftgate is operated.
- If a helper is riding the platform with you, make sure you are both doing so safely and that you are not in danger of coming in contact with any moving or potentially moving obstacles.
- USE GOOD COMMON SENSE.**
- If load appears to be unsafe, do not lift or lower it.

For a free copy of other manuals that pertain to the model Liftgate, please visit our website at www.maxorlift.com or call Customer Service at (800) 227-4116.

(I)

CAUTION

Always stand clear of platform area.

(E)

THE MAXIMUM CAPACITY OF THIS LIFT IS

3000 POUNDS

WHEN THE LOAD IS CENTERED ON THE LOAD CARRYING PLATFORM

(B)



WARNING

Liftgate hazards can result in crushing or falling. Keep hands and feet clear of pinch points. If riding liftgate, make sure load is stable and footing is solid.

Read and understand all instructions and WARNINGS before use.

(C)



(D)

WARNING



Never operate liftgate when walk ramp is extended. Always stow ramp before operating liftgate.

PIN 268454-01 (H)

OPERATING INSTRUCTIONS

GPTWR Series Liftgates

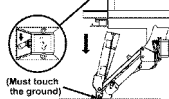
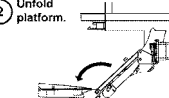
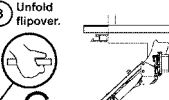
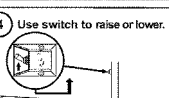
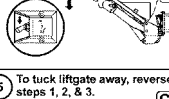
- Push control switch.  (Must touch the ground)
- Unfold platform. 
- Unfold flipover. 
- Use switch to raise or lower. 
- To tuck liftgate away, reverse steps 1, 2, & 3. 

(C)

DECAL SHEET
FIG. 11-1

FORKLIFT ADVISORY

⚠ WARNING

Keep forklift OFF of platform.

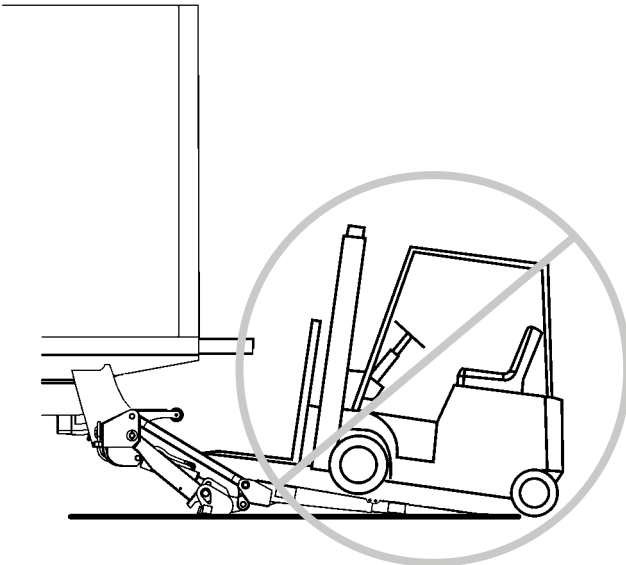
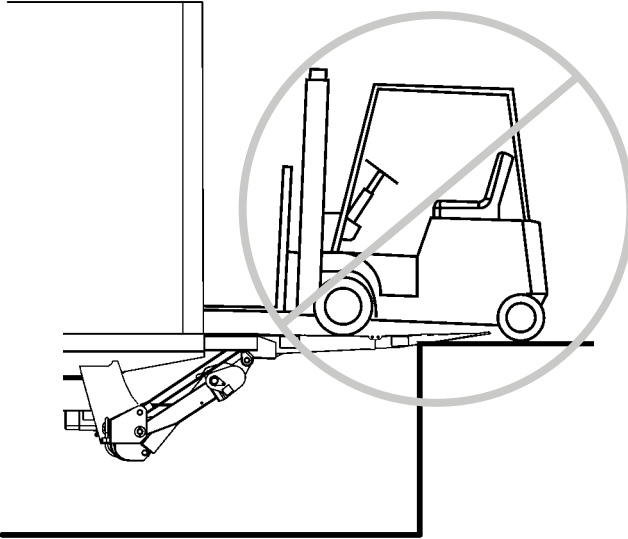

FIG. 12-1

ROADSIDE OPERATION ADVISORY

WARNING

Operating the Liftgate by the side of a busy road with vehicle traffic increases the chance of personal injury and damage to Liftgate, cargo & vehicle. Making the loading area more visible to passing traffic can help reduce the chance of injury and damage.

NOTE: MAXON recommends placing at least 2 traffic cones on the traffic side of the platform loading area as illustrated below. Remove cones after platform is stowed and before moving the vehicle.

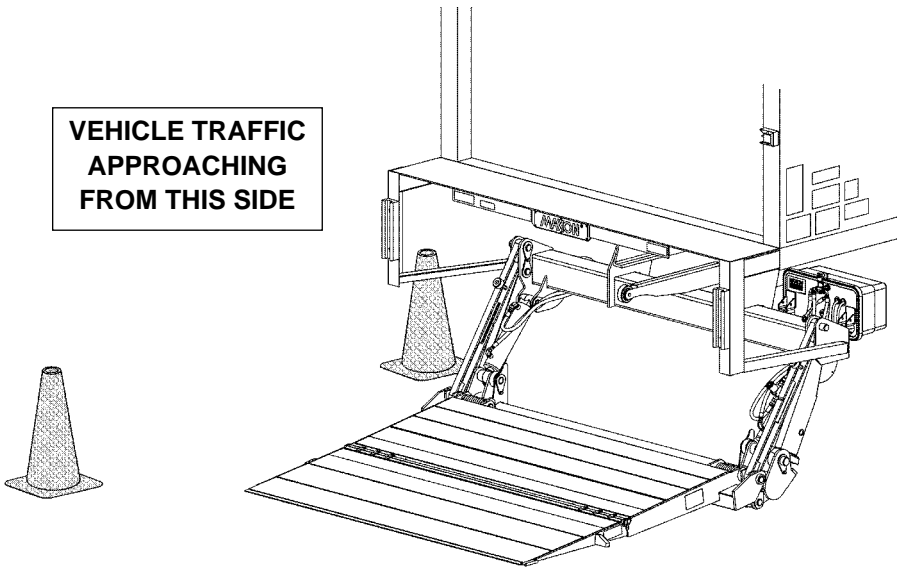

**TRAFFIC CONES POSITIONED BY PLATFORM LOADING AREA
(GPT LIFTGATE SHOWN)**

FIG. 13-1

OPERATION

NOTE: On vehicles equipped with the **GPTWR-3**, see the manufacturer's instructions to use walk ramp. Follow all the **WARNINGS & CAUTIONS** that apply to the walk ramp.

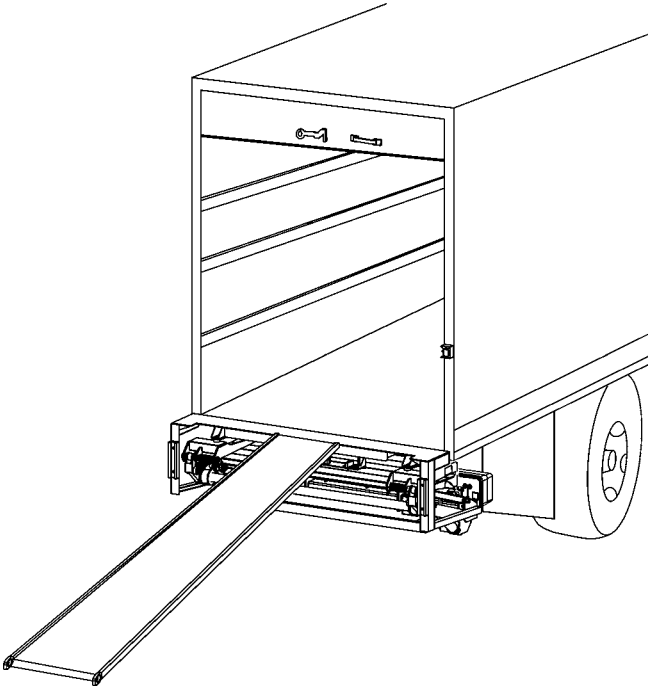

**TRUCK EQUIPPED WITH WALK RAMP & GPTWR-3 LIFTGATE
(LIFTGATE SHOWN STOWED &
RAMP SHOWN DEPLOYED)
FIG. 14-1**

1. Standing to the side of platform (**FIG. 15-1A**), push the toggle switch to the **UP** position as shown in **FIG. 15-1B**.

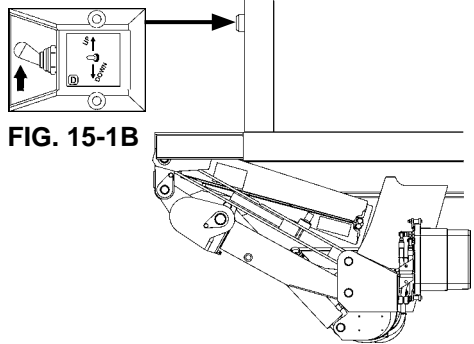
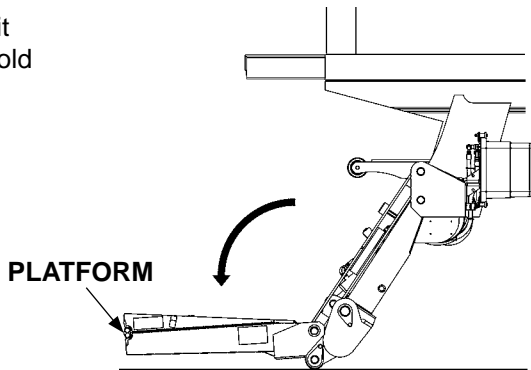

FIG. 15-1B

FIG. 15-1A

⚠ WARNING
Never operate control switch while unfolding platform.

2. Lower the platform until it touches the ground. Unfold platform (**FIG. 15-2**).



UNFOLDING PLATFORM
FIG. 15-2

OPERATION - Continued

3. Unfold the flipover (**FIG. 16-1**).

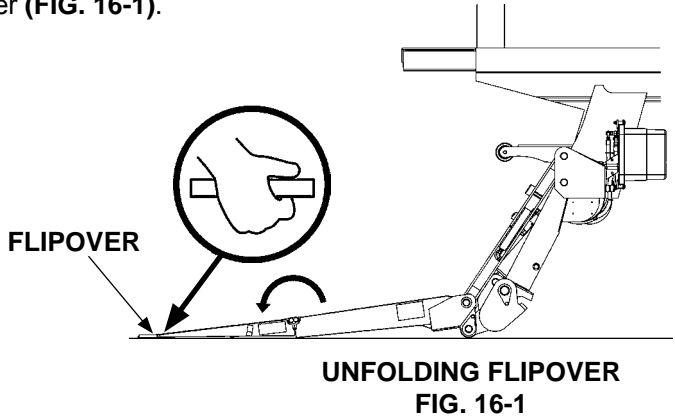

NOTE: While operating the Liftgate, release the toggle switch to stop the platform.

4. Raise the platform (**FIG. 16-2A**) by pushing the toggle switch to the **UP** position (**FIG. 16-2B**). Wait a second before releasing the toggle switch, after platform reaches bed height. To lower the platform, push the toggle switch to the **DOWN** position (**FIG. 16-2C**).

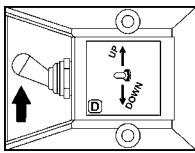

FIG. 16-2B

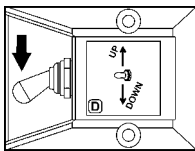
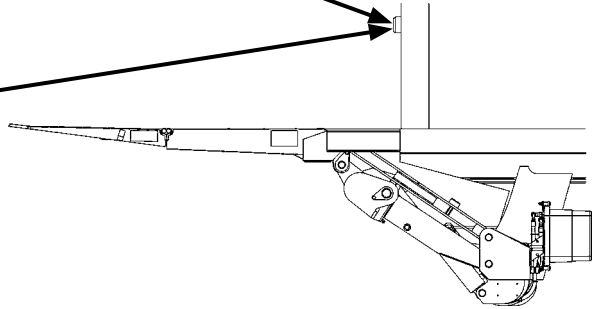

FIG. 16-2C



RAISING & LOWERING PLATFORM
FIG. 16-2A

⚠ WARNING

A load should never extend past the edges of the platform. Do not place unstable loads on platform and do not allow load to exceed the lifting capacity of the Liftgate. If standing on platform, do not allow your feet to extend beyond the inboard edge of the platform.

- 5. Load the platform at ground level as shown in FIG. 17-1.

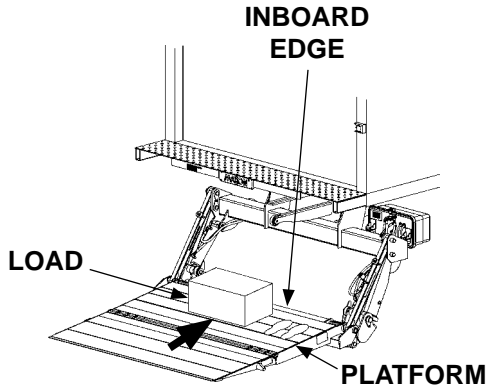

**LOADING PLATFORM AT GROUND LEVEL
FIG. 17-1**

- 6. Raise the platform to bed level (FIG. 17-2). Move load from platform to inside the vehicle body.

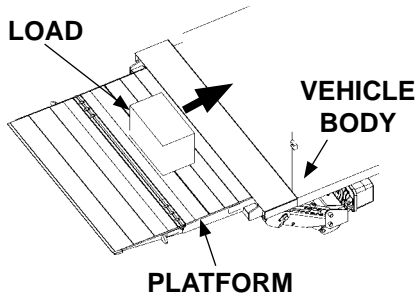

**UNLOADING PLATFORM AT BED LEVEL
FIG. 17-2**

OPERATION - Continued

WARNING

Pulling the load from vehicle to platform can result in a fall from platform and cause serious injury. When unloading vehicle, always push the load out on the platform.

7. Load the platform at bed level as follows. Push load out of the vehicle to correct position on the platform (**FIG. 18-1**). Place all loads as close as possible to the inboard edge of the platform with heaviest part toward the truck body as shown in **FIG. 18-1**. If standing on platform with the load, stand in the footprint area shown and comply with the **WARNING** on the previous page.

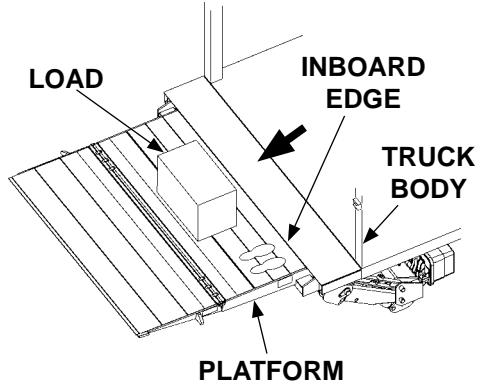

LOADING PLATFORM AT BED LEVEL
FIG. 18-1

8. Lower the platform to ground level (**FIG. 18-2**). Move load off the platform (**FIG. 18-2**).

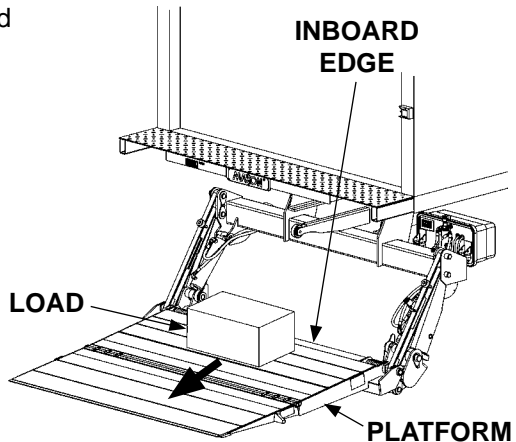

PLATFORM AT GROUND LEVEL
FIG. 18-2

⚠ WARNING

Never move the vehicle unless the Liftgate is properly stowed.

9. Before moving the vehicle, prepare the Liftgate as follows. Make sure load is removed from platform. If the platform is at bed height, push the toggle switch to the **DOWN** position as shown in **FIG. 19-1B**. Release toggle switch when platform touches the ground (**FIG. 19-1A**).

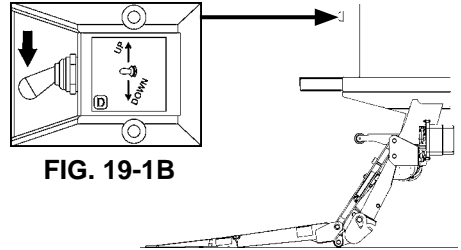

FIG. 19-1B

LOWERING LIFT
FIG. 19-1A

10. Stow the Liftgate by doing the following. Raise the platform 2" above the ground (**FIG. 19-2A**) by pushing the toggle switch to the **UP** position (**FIG. 19-2B**).

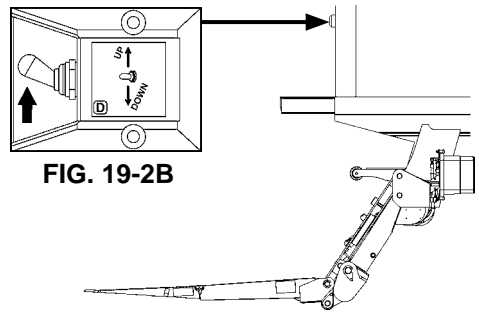

FIG. 19-2B

RAISING LIFT
FIG. 19-2A

OPERATION - Continued

⚠ WARNING

Keep hands clear of the platform support when folding flipover.

NOTE: Before folding flipover, make sure cart stops are stowed (if equipped).

11. Fold the flipover (FIG. 20-1).

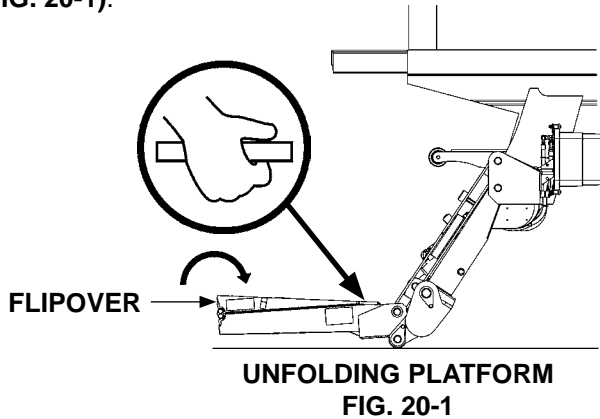

⚠ WARNING

Keep hands clear of the extension plate when folding the platform under the extension plate.

12. Fold the platform as shown in FIG. 20-2.

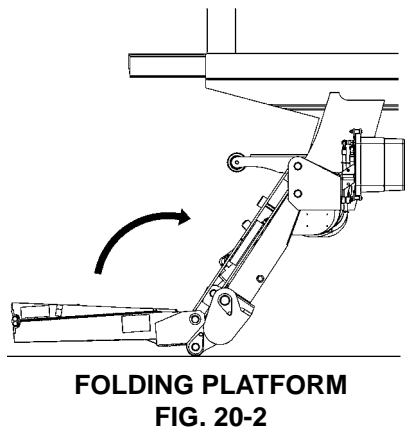

CAUTION

Stow Liftgate under hydraulic pressure.

13. Raise the Liftgate by pushing the toggle switch to the **UP** position (**FIG. 21-1B**). Wait a second before releasing toggle switch after Liftgate is raised all the way (**FIG. 21-1A**).

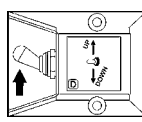
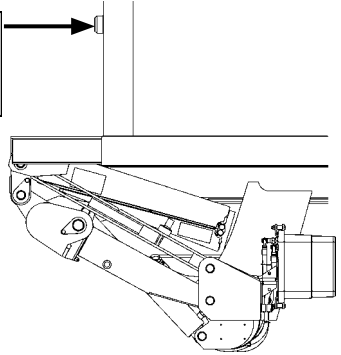

FIG. 21-1B



CORRECTLY STOWED LIFTGATE
FIG. 21-1A

USING CART STOPS (IF EQUIPPED)

⚠ CAUTION

To prevent injuries caused by tripping and falling, make sure cart stops are closed before walking on and off outboard end of platform.

NOTE: Some Liftgates are equipped with single or dual cart stops. Cart stops prevent loaded carts from rolling off outboard end of platform. Single cart stops are 1 section, about the same as overall width of platform, and operate with one set of controls. Dual cart stops are 2 identical sections, with a combined width about the same as overall width of platform, and each is independently operated with separate controls (1 set of controls per cart stop). The following procedure shows dual cart stops. A single cart stop operates the same way.

NOTE: Cart stops are usually closed when not in use. If you find the carts stops are already open when rolling a load from the ground to the platform, you may roll the load over the cart stop. The cart stop will close temporarily as the load crosses and reopen when the load is off the cart stop

1. At ground level, move load on platform with cart stops as shown in **FIG. 22-1**.

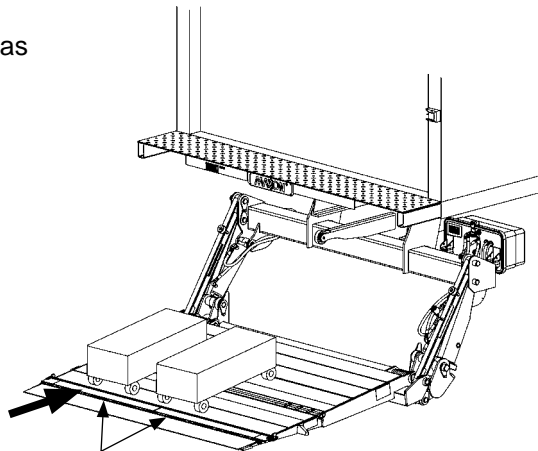

CART STOPS

LOADING PLATFORM AT GROUND LEVEL
(CART STOPS CLOSED)

FIG. 22-1

NOTE: Cart stops are opened by pushing on the hook (FIG. 23-1B).

2. Open cart stops (FIGS. 23-1A and 23-1B).

Next, position cart and stand in the footprint area as shown in FIG. 23-1A.

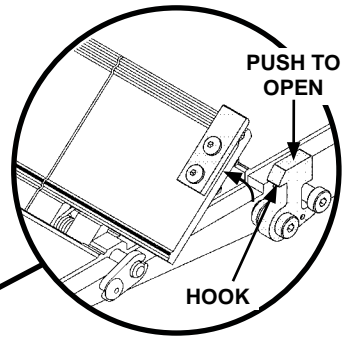

**OPENING CART STOPS
(RH SIDE OF FLIP OVER)
FIG. 23-1B**

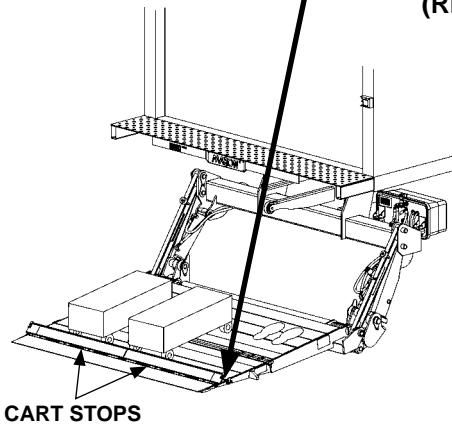

**CART STOPS OPEN
FIG. 23-1A**

3. Raise the platform to bed level (FIG. 23-2). Move the load off the platform into the vehicle body (FIG. 23-2).

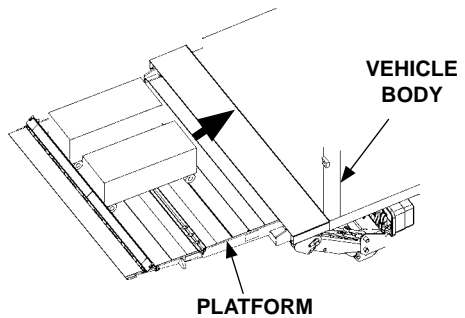

**UNLOADING PLATFORM AT BED LEVEL
(DUAL CART STOPS OPEN)
FIG. 23-2**

USING CART STOPS (IF EQUIPPED) - Continued

! WARNING

Pulling the load from vehicle to platform can result in a fall from platform and serious injury. When unloading vehicle, always push the load out on the platform.

4. When loading the platform at bed level, make sure cart stops are open (**FIG. 24-1**). Push load out of the vehicle to correct position on the platform. Place all loads as close as possible to the inboard edge of the platform with heaviest part toward the truck body as shown in **FIG. 24-1**. If standing on platform with the load, stand in the footprint area shown and comply with the **WARNING** on page 16.

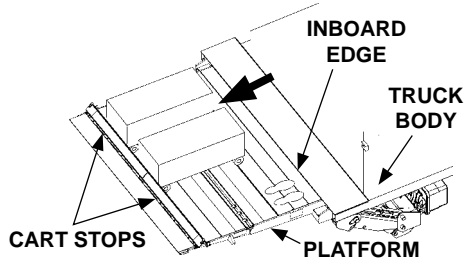

**LOADING PLATFORM AT BED LEVEL
(DUAL CART STOPS OPEN)**

FIG. 24-1

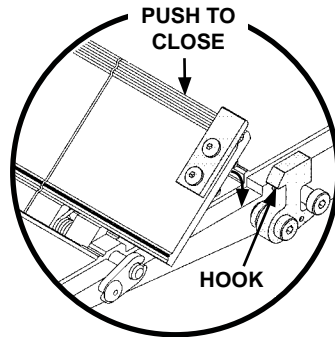

**CLOSING CART STOPS
(RH SIDE OF FLIP OVER)**

FIG. 24-2

5. Unload platform with cart stops at ground level as shown in **FIG. 24-3**. Make sure cart stops are closed before moving load off the platform. To close, push the cart stop and hook in place (**FIG. 24-2**).

6. Move load off the platform as shown in **FIG. 24-3**.

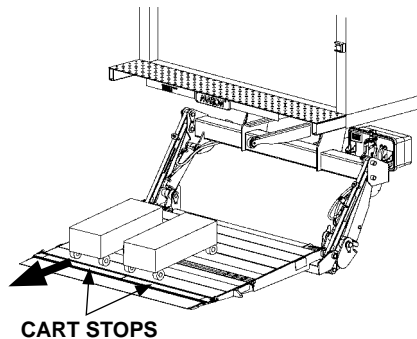

CART STOPS CLOSED

FIG. 24-3

